

**SANTA CRUZ CITY SCHOOLS DISTRICT
 REGULAR MEETING FOR THE ELEMENTARY
 AND SECONDARY DISTRICTS
 WEDNESDAY, August 17, 2022
 OPEN SESSION BEGINS AT 6:30 P.M.
 ZOOM REMOTE BOARD MEETING**

POSTED

DATE:

TIME:

LOCATION:

EMPLOYEE:

**COMMUNITY MEMBERS CAN PARTICIPATE REMOTELY VIA ZOOM OR
 IN PERSON AT THE COUNTY OFFICE OF EDUCATION, BOARD ROOM
 400 ENCINAL STREET, SANTA CRUZ, CA.**

MASKS ARE STRONGLY ENCOURAGED

[Click on this link to join meeting.](#)

Meeting Password: SCCS

If a member of the community would like to make public comment on a closed session item, please join Zoom. Public comment will begin promptly at 5:00 p.m.

[Click on this link to make public comment on a closed session item.](#)

AGENDA

Item	Purpose / Support
Agenda (Estimated Time)	
1. Convene Closed Session	5:00 p.m.
1.1. Roll Call	
1.2. Public Comments prior to Closed Session	<i>Members of the public may comment on items that ARE listed on the Closed Session Agenda.</i>
2. Closed Session Items	
2.1. Interdistrict Transfer Appeal Hearing Student #1	<i>Information for possible action.</i>
2.2. Interdistrict Transfer Appeal Hearing Student #2	<i>Information for possible action.</i>
2.3. Interdistrict Transfer Appeal Hearing Student #3	<i>Information for possible action.</i>
2.4. Certificated/Classified/Management Leaves, Retirements, Resignations & Appointments	<i>Information for possible action.</i>
2.5. Public Employee Discipline/Dismissal/Release/Complaint (Govt. Code Section 54957)	<i>Information for possible action.</i>
3. Convene Open Session	6:30 p.m.
3.1. Welcome	
3.2. Pledge of Allegiance	
3.3. Vote on IDT Appeal Student #1	
3.4. Vote on IDT Appeal Student #2	

SANTA CRUZ CITY SCHOOLS DISTRICT
REGULAR MEETING FOR THE ELEMENTARY
AND SECONDARY DISTRICTS
WEDNESDAY, August 17, 2022
OPEN SESSION BEGINS AT 6:30 P.M.
ZOOM REMOTE BOARD MEETING

**COMMUNITY MEMBERS CAN PARTICIPATE REMOTELY VIA ZOOM OR
IN PERSON AT THE COUNTY OFFICE OF EDUCATION, BOARD ROOM
400 ENCINAL STREET, SANTA CRUZ, CA.
MASKS ARE STRONGLY ENCOURAGED**

[Click on this link to join meeting.](#)

Meeting Password: SCCS

*If a member of the community would like to make public comment on a closed session
item, please join Zoom. Public comment will begin promptly at 5:00 p.m.*

[Click on this link to make public comment on a closed session item.](#)

POSTED

DATE:

TIME:

LOCATION:

EMPLOYEE:

AGENDA

Item	Purpose / Support
3.5. Vote on IDT Appeal Student #3	
3.6. Agenda Changes, Additions or Deletions & Announcements	
4. Public Comments	<i>For presentations of matters not on the Agenda. 3 minutes for individuals; 15 minutes per subject.</i> Note to Members of the Public: Thank you for taking the time to attend this meeting. Santa Cruz City School Board Members appreciate your presence and your comments regarding items not on the agenda are valued. Per Santa Cruz City Schools Board Bylaw protocols, Trustees will not comment on Public Comments during this time.
5. Superintendent's Report	
5.1. Superintendent's Report	
5.2. Students' Reports	
6. Board Members' Reports	
6.1. Board Members' Reports	
6.2. Board President's Report	
7. Approval of Minutes	
7.1. May 25 Minutes	
7.2. June 1 Minutes	
7.3. June 8 Minutes	

SANTA CRUZ CITY SCHOOLS DISTRICT
REGULAR MEETING FOR THE ELEMENTARY
AND SECONDARY DISTRICTS
WEDNESDAY, August 17, 2022
OPEN SESSION BEGINS AT 6:30 P.M.
ZOOM REMOTE BOARD MEETING

**COMMUNITY MEMBERS CAN PARTICIPATE REMOTELY VIA ZOOM OR
IN PERSON AT THE COUNTY OFFICE OF EDUCATION, BOARD ROOM
400 ENCINAL STREET, SANTA CRUZ, CA.
MASKS ARE STRONGLY ENGOURAGED**

[Click on this link to join meeting.](#)

Meeting Password: SCCS

*If a member of the community would like to make public comment on a closed session
item, please join Zoom. Public comment will begin promptly at 5:00 p.m.*

[Click on this link to make public comment on a **closed session item**.](#)

POSTED

DATE:

TIME:

LOCATION:

EMPLOYEE:

AGENDA

Item	Purpose / Support
7.4.	June 15 Minutes
7.5.	June 22 Minutes
8.	General Public Business
8.1.	Consent Agenda Non-Contract Items and Items to be Received: These matters may be passed by one roll call motion.
8.1.1.	Educational Services
8.1.1.1.	Fourth Quarter Williams Report
8.1.1.2.	PE Waiver: Santa Cruz High School
8.1.1.3.	Annual Application for Title I, Title II, Title III and Tile IV Funding-Elementary
8.1.1.4.	Annual Application for Title I, Title II, Title III and Tile IV Funding-Secondary
8.1.2.	Business Services
8.1.2.1.	Purchase Orders, Bids, & Quotes
8.1.2.2.	Warrant Register
8.1.2.3.	Budget Transfers
8.1.2.4.	Disposition of Surplus Property
8.1.2.5.	Bond Project Notice of Completion

SANTA CRUZ CITY SCHOOLS DISTRICT
 REGULAR MEETING FOR THE ELEMENTARY
 AND SECONDARY DISTRICTS
 WEDNESDAY, August 17, 2022
 OPEN SESSION BEGINS AT 6:30 P.M.
 ZOOM REMOTE BOARD MEETING

**COMMUNITY MEMBERS CAN PARTICIPATE REMOTELY VIA ZOOM OR
 IN PERSON AT THE COUNTY OFFICE OF EDUCATION, BOARD ROOM
 400 ENCINAL STREET, SANTA CRUZ, CA.
 MASKS ARE STRONGLY ENGOURAGED**
[Click on this link to join meeting.](#)

Meeting Password: SCCS

*If a member of the community would like to make public comment on a closed session
 item, please join Zoom. Public comment will begin promptly at 5:00 p.m.*

[Click on this link to make public comment on a closed session item.](#)

POSTED

DATE:

TIME:

LOCATION:

EMPLOYEE:

AGENDA

Item	Purpose / Support
8.1.2.6. Site Master Plan Update Proposals	
8.1.3. Human Resources	
8.1.3.1. Personnel Actions--Certificated	
8.1.3.2. Personnel Actions--Classified	
8.1.4. Governance/Superintendent	<i>None.</i>
8.2. Consent Agenda: General Contracts & Agreements	
8.2.1. Educational Services	
8.2.1.1. NonPublic School: The Bay School	
8.2.1.2. CDW-G: SmartBus	
8.2.1.3. Consultant Services Agreement: Santa Cruz High School	
8.2.1.4. iStation License Renewal	
8.2.1.5. Memorandum of Understanding: Special Education: SAIL	
8.2.1.6. Benchmark Books	
8.2.1.7. Lexia English: Professional Development	
8.2.1.8. Laptop Purchase	
8.2.1.9. Chromebook Purchase – Soquel & Santa Cruz High School	

SANTA CRUZ CITY SCHOOLS DISTRICT
REGULAR MEETING FOR THE ELEMENTARY
AND SECONDARY DISTRICTS
WEDNESDAY, August 17, 2022
OPEN SESSION BEGINS AT 6:30 P.M.
ZOOM REMOTE BOARD MEETING

**COMMUNITY MEMBERS CAN PARTICIPATE REMOTELY VIA ZOOM OR
IN PERSON AT THE COUNTY OFFICE OF EDUCATION, BOARD ROOM
400 ENCINAL STREET, SANTA CRUZ, CA.
MASKS ARE STRONGLY ENGOURAGED**
[Click on this link to join meeting.](#)

Meeting Password: SCCS

*If a member of the community would like to make public comment on a closed session
item, please join Zoom. Public comment will begin promptly at 5:00 p.m.*

[Click on this link to make public comment on a **closed session item.**](#)

POSTED

DATE:

TIME:

LOCATION:

EMPLOYEE:

AGENDA

Item	Purpose / Support
8.2.2. Business Services	
8.2.2.1. Keenan: Excess Cyber Liability Proposal	
8.2.2.2. Food Services Agreement with Pacific Collegiate School	
8.2.2.3. Food Services Agreement with COE	
8.2.2.4. Memorandum of Understanding: Transportation Services: SCCS & COE	
8.2.2.5. Bay View Elementary Portable Classroom Purchase	
8.2.3. Human Resources	
8.2.3.1. Consultant Services Agreement: Lisa Fraser	
8.2.3.2. University Memorandums of Understanding	
8.2.4. Governance/Superintendent	
8.2.4.1. Monday.com Renewal	
8.2.4.2. Nasdaq Agreement Renewal	
8.3. Consent Agenda: Bond Projects Contracts, Agreements, Proposals, Bids & Change Orders	
8.3.1 American Modular Systems: Change Order 3: Gault Elementary School Modular Classroom Building	

**SANTA CRUZ CITY SCHOOLS DISTRICT
 REGULAR MEETING FOR THE ELEMENTARY
 AND SECONDARY DISTRICTS
 WEDNESDAY, August 17, 2022
 OPEN SESSION BEGINS AT 6:30 P.M.
 ZOOM REMOTE BOARD MEETING**

**COMMUNITY MEMBERS CAN PARTICIPATE REMOTELY VIA ZOOM OR
 IN PERSON AT THE COUNTY OFFICE OF EDUCATION, BOARD ROOM
 400 ENCINAL STREET, SANTA CRUZ, CA.
 MASKS ARE STRONGLY ENGOURAGED
[Click on this link to join meeting.](#)**

Meeting Password: SCCS

**POSTED
 DATE:
 TIME:
 LOCATION:
 EMPLOYEE:**

If a member of the community would like to make public comment on a closed session item, please join Zoom. Public comment will begin promptly at 5:00 p.m.

[Click on this link to make public comment on a closed session item.](#)

AGENDA

Item	Purpose / Support
8.3.2.	<u>Atlantis Paving & Grading: Change Order 1: Bay View Elementary School Site Work</u>
8.3.3.	<u>Belli Architectural Group: Amendment Agreement: Multiproject Overhead</u>
8.3.4.	<u>Bosco Construction Services, Inc.: Proposal: Harbor High School Bathroom Paint</u>
8.3.5.	<u>Consolidated Plumbing: Proposal: Bay View Elementary School Storm Drain Repairs</u>
8.3.6.	<u>Creative Window Interiors: Proposal: DeLaveaga Elementary School Window Shades</u>
8.3.7.	<u>CRW Industries Inc.: Change Order 6: Santa Cruz High School Switchgear Replacement</u>
8.3.8.	<u>CRW Industries Inc.: Proposal: Harbor High Food Service Office Disposal</u>
8.3.9.	<u>Development Group Inc.: Proposal: Soquel High School Vape Detectors</u>
8.3.10.	<u>Dilbeck & Sons: Proposal: Touch Panel Installation</u>
8.3.11.	<u>Fiber Optic Telecom International: Proposal: Districtwide Electronic Key Card System Set-Up</u>
8.3.12.	<u>Geo H Wilson: Proposal: Westlake Elementary School Waste Line Repair</u>
8.3.13.	<u>Hancock Park & DeLong: Change Order 1: Grant Consulting Services</u>

SANTA CRUZ CITY SCHOOLS DISTRICT
REGULAR MEETING FOR THE ELEMENTARY
AND SECONDARY DISTRICTS
WEDNESDAY, August 17, 2022
OPEN SESSION BEGINS AT 6:30 P.M.
ZOOM REMOTE BOARD MEETING

**COMMUNITY MEMBERS CAN PARTICIPATE REMOTELY VIA ZOOM OR
IN PERSON AT THE COUNTY OFFICE OF EDUCATION, BOARD ROOM
400 ENCINAL STREET, SANTA CRUZ, CA.
MASKS ARE STRONGLY ENGOURAGED**

[Click on this link to join meeting.](#)

Meeting Password: SCCS

*If a member of the community would like to make public comment on a closed session
item, please join Zoom. Public comment will begin promptly at 5:00 p.m.*

[Click on this link to make public comment on a **closed session item.**](#)

POSTED

DATE:

TIME:

LOCATION:

EMPLOYEE:

AGENDA

Item	Purpose / Support
8.3.14.	ID Distributors: Quote: Districtwide Electronic Key Cards
8.3.15.	Leach Group: Change Order: New Switch Gear Inspections
8.3.16.	Lewis and Tibbitts Inc.: Change Order 4: Mission Hill Middle School Switchgear Replacement
8.3.17.	MBC Enterprises: Change Order 4: Santa Cruz High School Underground Utility Replacement
8.3.18.	Monterey Peninsula Engineering: Change Order 1: Maintenance Facility Yard Repaving
8.3.19.	Netxperts: Proposal: DeLaveaga Elementary and Westlake Elementary School Door Hardware Installation
8.3.20.	Overhead Door: Proposal: Harbor High School Door Repair
8.3.21.	San Lorenzo Lumber: Proposal: Facilities Door Hardware
8.3.22.	SC Systems: Proposal: Portable Building Electrical and IDF Demolition
8.3.23.	Verde Design: Change Order 2: Santa Cruz High School Baseball Backstop Modifications
8.3.24.	WallaceKuhl & Associates: Proposal: Soquel High School Fitness Modernization Special Inspection Services

**SANTA CRUZ CITY SCHOOLS DISTRICT
 REGULAR MEETING FOR THE ELEMENTARY
 AND SECONDARY DISTRICTS
 WEDNESDAY, August 17, 2022
 OPEN SESSION BEGINS AT 6:30 P.M.
 ZOOM REMOTE BOARD MEETING**

**COMMUNITY MEMBERS CAN PARTICIPATE REMOTELY VIA ZOOM OR
 IN PERSON AT THE COUNTY OFFICE OF EDUCATION, BOARD ROOM
 400 ENCINAL STREET, SANTA CRUZ, CA.
 MASKS ARE STRONGLY ENCOURAGED**
[Click on this link to join meeting.](#)

Meeting Password: SCCS

**POSTED
 DATE:
 TIME:
 LOCATION:
 EMPLOYEE:**

If a member of the community would like to make public comment on a closed session item, please join Zoom. Public comment will begin promptly at 5:00 p.m.

[Click on this link to make public comment on a closed session item.](#)

AGENDA

Item	Purpose / Support
8.4. Report of Closed Session Actions	
8.4.1. Report of Actions Taken in Closed Session	
8.5. Items to Be Transacted and/or Discussed	
8.5.1. Educational Services	
8.5.1.1. Staff Report: Summer School Report	<i>Staff will present the annually required Summer School report.</i>
8.5.1.2. Staff Report: Interdistrict Transfers & Open Enrollment	<i>Staff will present an annual report on Interdistrict Transfers and Open Enrollment.</i>
8.5.2. Business Services	
8.5.2.1. Staff Report: Bond Project Update	<i>Staff will provide an update on Bond Projects.</i>
8.5.2.2. New Business: AB1200 for Tentative Agreement with GSCFT	<i>Recommendation: Approve the AB1200 for Tentative Agreement with GSCFT.</i>
8.5.2.3. New Business: AB1200 for Tentative Agreement with SCCCE	<i>Recommendation: Approve the AB1200 for Tentative Agreement with SCCCE.</i>
8.5.3. Human Resources	
8.5.3.1. Staff Report: New Employee Report	<i>Staff will present the New Employee Report</i>
8.5.3.2. Tentative Agreement between SCCS and GSCFT	<i>Recommendation: Approve the tentative agreement between SCCS/GSCFT</i>
8.5.3.3. Tentative Agreement between SCCS and SCCCE	<i>Recommendation: Approve the tentative agreement between SCCS/SCCCE</i>
8.5.4. Governance/Superintendent	

SANTA CRUZ CITY SCHOOLS DISTRICT
REGULAR MEETING FOR THE ELEMENTARY
AND SECONDARY DISTRICTS
WEDNESDAY, August 17, 2022
OPEN SESSION BEGINS AT 6:30 P.M.
ZOOM REMOTE BOARD MEETING

**COMMUNITY MEMBERS CAN PARTICIPATE REMOTELY VIA ZOOM OR
IN PERSON AT THE COUNTY OFFICE OF EDUCATION, BOARD ROOM
400 ENCINAL STREET, SANTA CRUZ, CA.
MASKS ARE STRONGLY ENGOURAGED**

[Click on this link to join meeting.](#)

Meeting Password: SCCS

POSTED

DATE:

TIME:

LOCATION:

EMPLOYEE:

*If a member of the community would like to make public comment on a closed session
item, please join Zoom. Public comment will begin promptly at 5:00 p.m.*

[Click on this link to make public comment on a closed session item.](#)

AGENDA

Item	Purpose / Support
8.5.4.1. Staff Report: Update - Lessons Learned During the Pandemic	<i>Staff will provide an update on the Lessons Learned During the Pandemic.</i>
8.5.4.2. New Business: CSBA Board Policies	<i>Recommendation: Approve the CSBA Board Policies for first or final reading.</i>
8.5.4.2. Possible Items for Future Meeting Agendas	
9. Adjournment	
10. Return to Closed Session (if necessary)	
11. Closed Session Action Report (if necessary)	
12. Adjournment	

The board book for this meeting, including this agenda and back-up materials, may be viewed or downloaded online: http://sccs.net/board_of_education or may be viewed at the District Office, 133 Mission St. Ste. 100, Santa Cruz, CA 95060.

Public Participation:

All persons are encouraged to attend and, when appropriate, to participate in meetings of the Santa Cruz City Schools Board of Education. If you wish to speak to an item on the agenda, please be present at the beginning of the meeting as any item, upon motion, may be moved to the beginning of the agenda. Consideration of all matters is conducted in open session except those relating to litigation, personnel and employee negotiations, which, by law, may be considered in closed session.

Translation Requests:

Spanish language translation is available on an as-needed basis. Please make advance arrangements with Alyssa Martinez by telephone at (831) 429-3410 extension 48220.

Las Solicitudes de Traducción:

Traducciones del inglés al español y del español al inglés están disponibles en las sesiones de la mesa directiva. Por favor haga arreglos por anticipado con Alyssa Martinez por teléfono al numero (831) 429-3410 x48220.

**SANTA CRUZ CITY SCHOOLS DISTRICT
REGULAR MEETING FOR THE ELEMENTARY
AND SECONDARY DISTRICTS
WEDNESDAY, August 17, 2022
OPEN SESSION BEGINS AT 6:30 P.M.
ZOOM REMOTE BOARD MEETING**

**COMMUNITY MEMBERS CAN PARTICIPATE REMOTELY VIA ZOOM OR
IN PERSON AT THE COUNTY OFFICE OF EDUCATION, BOARD ROOM
400 ENCINAL STREET, SANTA CRUZ, CA.
MASKS ARE STRONGLY ENGOURAGED**

[Click on this link to join meeting.](#)

Meeting Password: SCCS

POSTED

DATE:

TIME:

LOCATION:

EMPLOYEE:

If a member of the community would like to make public comment on a closed session item, please join Zoom. Public comment will begin promptly at 5:00 p.m.

[Click on this link to make public comment on a closed session item.](#)

AGENDA

Board Meeting Information

1. The Regular Board Meeting on August 17, 2022, 6:30 p.m., at the Santa Cruz County Office of Education, and will be broadcast to the public remotely via Zoom.
2. The Regular Board Meeting on August 31, 2022, 6:30 p.m., at the Santa Cruz County Office of Education, and will be broadcast to the public remotely via Zoom.
3. The Regular Board Meeting on September 14, 2022, 6:30 p.m., at the Santa Cruz County Office of Education, and will be broadcast to the public remotely via Zoom.
4. The Regular Board Meeting on September 28, 2022, 6:30 p.m., at the Santa Cruz County Office of Education, and will be broadcast to the public remotely via Zoom.
5. The Regular Board Meeting on October 19, 2022, 6:30 p.m., at the Santa Cruz County Office of Education, and will be broadcast to the public remotely via Zoom.
6. The Regular Board Meeting on November 2, 2022, 6:30 p.m., at the Santa Cruz County Office of Education, and will be broadcast to the public remotely via Zoom.
7. The Study Session on November 16, 2022, 6:30 p.m., at the Santa Cruz County Office of Education, and will be broadcast to the public remotely via Zoom.
8. The Regular Board Meeting on December 14, 2022, 6:30 p.m., at the Santa Cruz County Office of Education, and will be broadcast to the public remotely via Zoom.
9. The Study Session on December 21, 2022, 6:30 p.m., at the Santa Cruz County Office of Education, and will be broadcast to the public remotely via Zoom.
10. The Regular Board Meeting on January 11, 2023, 6:30 p.m., at the Santa Cruz County Office of Education, and will be broadcast to the public remotely via Zoom.
11. The Study Session on January 18, 2023, 6:30 p.m., at the Santa Cruz County Office of Education, and will be broadcast to the public remotely via Zoom.
12. The Regular Board Meeting on February 8, 2023, 6:30 p.m., at the Santa Cruz County Office of Education, and will be broadcast to the public remotely via Zoom.
13. The Regular Board Meeting on February 22, 2023, 6:30 p.m., at the Santa Cruz County Office of Education, and will be broadcast to the public remotely via Zoom.

**SANTA CRUZ CITY SCHOOLS DISTRICT
REGULAR MEETING FOR THE ELEMENTARY
AND SECONDARY DISTRICTS
WEDNESDAY, August 17, 2022
OPEN SESSION BEGINS AT 6:30 P.M.
ZOOM REMOTE BOARD MEETING**

**COMMUNITY MEMBERS CAN PARTICIPATE REMOTELY VIA ZOOM OR
IN PERSON AT THE COUNTY OFFICE OF EDUCATION, BOARD ROOM
400 ENCINAL STREET, SANTA CRUZ, CA.
MASKS ARE STRONGLY ENGOURAGED**

[Click on this link to join meeting.](#)

Meeting Password: SCCS

POSTED

DATE:

TIME:

LOCATION:

EMPLOYEE:

If a member of the community would like to make public comment on a closed session item, please join Zoom. Public comment will begin promptly at 5:00 p.m.

[Click on this link to make public comment on a closed session item.](#)

AGENDA

14. The Regular Board Meeting on March 8, 2023, 6:30 p.m., at the Santa Cruz County Office of Education, and will be broadcast to the public remotely via Zoom.
15. The Regular Board Meeting on March 22, 2023, 6:30 p.m., at the Santa Cruz County Office of Education, and will be broadcast to the public remotely via Zoom.
16. The Regular Board Meeting on April 12, 2023, 6:30 p.m., at the Santa Cruz County Office of Education, and will be broadcast to the public remotely via Zoom.
17. The Study Session on April 26, 2023, 6:30 p.m., at the Santa Cruz County Office of Education, and will be broadcast to the public remotely via Zoom.
18. The Regular Board Meeting on May 10, 2023, 6:30 p.m., at the Santa Cruz County Office of Education, and will be broadcast to the public remotely via Zoom.
19. The Study Session on May 24, 2023, 6:30 p.m., at the Santa Cruz County Office of Education, and will be broadcast to the public remotely via Zoom.
20. The Regular Board Meeting on May 31, 2023, 6:30 p.m., at the Santa Cruz County Office of Education, and will be broadcast to the public remotely via Zoom.
21. The Regular Board Meeting on June 14, 2023, 6:30 p.m., at the Santa Cruz County Office of Education, and will be broadcast to the public remotely via Zoom.

**MINUTES OF THE STUDY SESSION
OF THE SANTA CRUZ CITY SCHOOLS BOARD OF EDUCATION
FOR THE ELEMENTARY AND SECONDARY DISTRICTS
MAY 25, 2022**

Convene Closed Session

Board President Tracy-Proulx called this Closed Session Meeting to order at 5:00 p.m.

Public Comments for Closed Session Agenda Items

None

Convene Open Session

Board President Tracy-Proulx called this Regular Meeting Open Session to order at 6:11 p.m.

Attendance at Meeting

Sheila Coonerty	Cindy Ranii	Jeremy Shonick
Patricia Threet	Deb Tracy-Proulx	

Kris Munro, Superintendent
Jim Monreal, Assistant Superintendent, Business Services
Molly Parks, Assistant Superintendent, Human Resources
Members of the Audience

Absent: Vice President John Owen
Trustee Claudia Vestal
Assistant Superintendent Dorothy Coito
Student Board Representative Laura Wang
Student Board Representative Destiny Silva

Welcome and Format

Board President Tracy-Proulx welcomed those in attendance and explained the format used for this Study Session of the Board of Education.

3.2. Agenda Changes, Additions, or Deletions & Announcements

Board President Tracy-Proulx acknowledged the recent tragedy in Uvalde, Texas.

PUBLIC COMMENTS

None.

GENERAL PUBLIC BUSINESS

Closed Session Items

Report of Actions Taken in Closed Session

Board President Tracy-Proulx reported the following actions during closed session:

1. Ms. Parks shared information with the Board on Certificated/Classified/Management Leaves, Retirements, Resignations & Appointments.
2. The Board discussed public employee performance evaluation (Govt. Code Section 54957)

ITEMS TO BE TRANSACTED AND/OR DISCUSSED

5.2.1. Study Session: Budget

The Governor's May Review

Assistant Superintendent Monreal reviewed the May Review from the Governor and drew attention to the fact that districts are being asked to start programs without any additional funding or with one-time monies. Trustees asked questions and had discussion.

District Budget Development 22-23

Assistant Superintendent Monreal reviewed the budget that is being developed for 2022-23. The budget will come forward for a public hearing on June 1, 2022. Information reported by Mr. Monreal included: a review of Santa Cruz City Schools budget principals; budget highlights and assumptions; revenue and expenditure summaries; impact to 2022-23 fund balance; revenue sources and projection; multi-year budget assumptions and multi-year projections; local and state funding descriptions; parcel taxes; and Local Control Accountability Plan supplemental resources. Trustees asked questions and had discussion.

Basic Aid Reserve

Assistant Superintendent Monreal shared updates to the Basic Aid Reserve with Trustees.

Redevelopment Agency Funds

Assistant Superintendent Monreal discussed the Redevelopment Agency Funds. Mr. Monreal shared projected RDA revenue in the 22-23 school year and planned projects including the Soquel High School Theater. Trustees asked questions and had discussion.

6. Adjournment of Meeting

As there was no further business to come before the Board of Education, Board President Tracy-Proulx adjourned this Study Session at 7:48 p.m.

Board Meeting Schedule Information

1. The Study Session on May 25, 2022, 6:30 p.m., at the Santa Cruz County Office of Education, and will be broadcast to the public remotely via Zoom.
2. The Regular Meeting on June 1, 2022, 6:30 p.m., at the Santa Cruz County Office of Education, and will be broadcast to the public remotely via Zoom.
3. The Regular Meeting on June 8, 2022, 6:30 p.m., at the Santa Cruz County Office of Education, and will be broadcast to the public remotely via Zoom.
4. The Regular Meeting on June 15, 2021, 6:30 p.m., at the Santa Cruz County Office of Education, and will be broadcast to the public remotely via Zoom.

*For more details about this meeting, please visit our district website and listen to the meeting recording: http://sccs.net/board_of_education

Respectfully submitted,

Kris Munro, Superintendent
Santa Cruz City Schools

Deb Tracy-Proulx, President
Board of Education

**MINUTES OF THE REGULAR MEETING
OF THE SANTA CRUZ CITY SCHOOLS BOARD OF EDUCATION
FOR THE ELEMENTARY AND SECONDARY DISTRICTS
JUNE 1, 2022**

Convene Closed Session

Board President Tracy-Proulx called this Closed Session Meeting to order at 5:30 p.m.

Public Comments for Closed Session Agenda Items

None.

Convene Open Session

Board President Tracy-Proulx called this Regular Meeting Open Session to order at 6:30 p.m.

Attendance at Meeting

Sheila Coonerty	John Owen	Cindy Ranii	Jeremy Shonick
Patricia Threet	Deb Tracy-Proulx	Claudia Vestal	

Student Board Representative Destiny Silva

Kris Munro, Superintendent
Dorothy Coito, Assistant Superintendent, Educational Services
Jim Monreal, Assistant Superintendent, Business Services
Molly Parks, Assistant Superintendent, Human Resources
Members of the Audience

Absent: Student Board Representative Laura Wang

Welcome and Format

Board President Tracy-Proulx welcomed those in attendance and explained the format used for this Regular Meeting of the Board of Education.

3.3. Agenda Changes, Additions, or Deletions & Announcements

Item 8.2.1.16. Stop It Solutions: Contract was pulled from the consent agenda, as staff are researching another option that may better serve the needs of the District.

3.4. Recognition of AAPI Essay and Art Contest Winners and Participants

Superintendent Munro recognized and honored the winners and participants of the District's first annual AAPI Heritage Month Essay and Art Contest. The District will be hosting a contest for every heritage or history month.

PUBLIC COMMENTS

GSCFT President Casey Carlson addressed the board to share negotiations regarding wage increase began a few weeks ago. She acknowledged that the District may not be able to keep up with the inflation rates, but she asked the board respectfully consider wage increases for school workers.

Food Services Director Amy Hedrick-Farr shared that the Food Services department is still offering daily meals to the community, even though school is out of session for the summer. The daily meal is distributed at 1pm at Gault Elementary school.

SUPERINTENDENT'S REPORT

Superintendent's Report

Superintendent Munro reviewed COVID data and trends in Santa Cruz County and Santa Cruz City Schools. Inspire Diagnostics will continue to provide screening testing for interested parties and exposure testing in the 22-23 school year, and the testing and vaccination sites at the County Office of Education will remain open throughout the summer. Superintendent Munro shared photos and updates of the graduation and promotion ceremonies. High schools also hosted their senior awards nights. The English Learner Master Plan has been completed and will be shared with the Board for a first reading. Staff had their end of year Computer Science for All meeting and learned the District will likely receive another grant to support computer science. Staff and Trustees attended the Queer Youth Leadership Awards. Superintendent Munro participated in a planning day with Student Services where staff discussed how to provide multiple tiers of support for social-emotional student needs. The Elementary Curriculum and Assessment teams had their closing meeting on May 31 and the High School history/social science team met with Director Hodges to discuss the new graduation requirement of Ethnic Studies. Staff have been planning for the August SCIL day. Staff also attended the Governor's May Revise workshop. Superintendent Munro concluded her report by sharing a newsletter that was sent to families, reassuring the community of safety measures that are currently in place on all campuses, and improvements that are forthcoming.

Student's Report

Student Board Representative Destiny Silva congratulated four Harbor athletic teams who celebrated championships. She also shared activities that occurred on campus the week before finals, to celebrate and commemorate the Class of 2022.

BOARD MEMBERS' REPORTS

Board Members' Reports

Trustee Ranii did not have a report to share.

Trustee Shonick did not have a report to share.

Trustee Vestal attended Delta's Open House where she was able to meet incoming students and families, and current students were able to sell their art. Trustee Vestal also attend ARK and Costanoa's graduation ceremonies. Both ceremonies featured student and family speakers. The Adult School also celebrated end of year accomplishments including students graduating with certificates in various health fields, receiving citizenship papers, or completing GED or high school equivalency requirements.

Trustee Threet attended Soquel High School's graduation ceremony and reported it was a very touching ceremony with meaningful speakers.

Vice President Owen did not have a report to share.

Trustee Coonerty did not have a report to share.

Board President's Report

Board President Tracy-Proulx attended graduation and promotion ceremonies for Branciforte Middle, Harbor High, and Santa Cruz High. All were lovely and spirited celebrations. President Tracy-Proulx also congratulated Student Board Representative Laura Wang for receiving the Superintendent's Award for the highest overall GPA at Santa Cruz High School.

APPROVAL OF MINUTES

1. MSP (Vestal/Owen) 7-0, the Board of Education approved the Minutes for April 13, 2022.
2. MSP (Vestal/Coonerty) 7-0, the Board of Education approved the Minutes for April 27, 2022.
3. MSP (Coonerty/Owen) 7-0, the Board of Education approved the Minutes for May 4, 2022.

GENERAL PUBLIC BUSINESS

Consent Agenda

8.1.2.1. Purchase Orders, Bids, & Quotes, 8.1.2.2. Warrant Register, 8.1.2.3. Disposition of Surplus Property, 8.1.2.4. New Business: Resolution 35-21-22: Authorized Signatures 2022-23, 8.1.3.1. Personnel Actions—Certificated, 8.1.3.2. Personnel Actions—Classified, 8.1.3.3. New Job Description: Paraeducator – Transitional Kindergarten/Preschool, 8.2.1.1. Your Future is Our Business Annual Agreement 2022-23, 8.2.1.2. Consultant Services Agreement: Organized Binder, 8.2.1.3. Advancement Via Individual Determination (AVID) Contract Renewal, 8.2.1.4. Service Agreement Renewal: Turnitin, LLC., 8.2.1.5. Curriculum Contract Renewal: Newsela, 8.2.1.6. PearDeck License Renewal, 8.2.1.7. Screencastify Contract Renewal, 8.2.1.8. Curriculum Associates Contract Renewal: iReady – Elementary, 8.2.1.9. Achieve 3000 Contract Renewal, 8.2.1.10. Zearn Account Renewal, 8.2.1.11. EdPuzzle Contract Renewal, 8.2.1.12. Education Software for Guiding Instruction License Renewal, 8.2.1.13. Edgenuity Contract Renewal, 8.2.1.14. Memorandum of Understanding: Encompass Services, 8.2.1.15. Memorandum of Understanding: Monarch Services, 8.2.1.16. Stop It Solutions: Contract, 8.2.1.17. Memorandum of Understanding: Santa Cruz County Office of Education Career Technical Education: IT Essentials, 8.2.1.18. Second Step Curriculum License Renewal, 8.2.1.19. Beyond SST Contract, 8.2.1.20. Amplified IT License Renewal, 8.2.2.1. Consultant Services Agreement: Miller Maxfield, Inc., 8.2.2.2. Food Service Bids: 2022-23, 8.2.2.3. Mobile Modular Quote: DeLaveaga Elementary School Portable Classroom Removal, 8.2.2.4. Career Catalyst Program Agreement: Chef Ann Foundation, 8.2.3.1. Palo Alto Medical Foundation Grant Agreement: Athletic Trainer, 8.2.4.1. Legal Services Agreement 2022-23 and 2023-24: Dannis Woliver Kelly, 8.2.4.2. Consultant Services Agreement: Carolyn Post, 8.3.1 Albion Environmental: Change Order 2: Santa Cruz High School Underground Utility Replacement Construction Monitoring, 8.3.2. Anaya Construction: Proposal: Bay View Elementary School Portable Classroom Removal, 8.3.3. Atlantis Paving & Grading: Contract: Bay View Elementary School Site Work, 8.3.4. AVNow: Proposal: Branciforte Middle School Replacement Performing Arts Equipment, 8.3.5. Best Contracting Services, Inc.: Contract: Harbor High School Gym Reroof, 8.3.6. Bosco Construction Services, Inc.: Proposal: DeLaveaga Elementary School Portable Classroom Floor Repairs, 8.3.7. Cyclone Fence & Iron: Change Order 2: Westlake Elementary School Site Fencing and Gates, 8.3.8. M3 Environmental: Proposal: Gault Elementary School Hazardous Materials Inspections, 8.3.9. Sierra School Equipment Co. Proposal Bay View Elementary School Student Desk Book Boxes

Trustee Vestal motioned to approve the consent agenda. Vice President Owen seconded the motion.

The motion was passed by the following roll call vote:

Roll Call Vote:

Coonerty – Yes Owen – Yes Ranii – Yes
Shonick – Yes Threet – Yes Tracy-Proulx – Yes Vestal – Yes

Closed Session Items

Report of Actions Taken in Closed Session

Vice President Owen reported the following actions during closed session:

1. Ms. Parks did not have information to share with the Board on Certificated/Classified/Management Leaves, Retirements, Resignations & Appointments.
2. Ms. Parks did not have information to share regarding Public Employee Discipline/Dismissal/Release/Complaints
3. The Board President represented SCCS in negotiations regarding the Superintendent’s Annual Contract Review

ITEMS TO BE TRANSACTED AND/OR DISCUSSED

8.5.1.1. Staff Report: English Learner Master Plan First Reading

Elementary Director of Curriculum and Instruction, Shannon Calden, presented the first reading of Santa Cruz City Schools’ English Learner Master Plan. Approximately 30% of the SCCS students are classified as Multilingual Learners. The intent of the English Learner Master Plan is to serve as a quick reference guide to help the community and staff find information on District practices to support English learners, codify the District’s commitment to English Learners, provide the system and requirements for supporting English Learners in making adequate annual progress towards English proficiency, and outline the district’s adherence to all federal and state legal requirements as they relate to serving English Learners who have not yet reclassified as proficient in English. This plan was developed with input from teachers, district and site administrators, parents of Multilingual and English Learners, as well as from Multilingual/English Learner students. The English Learner Master Plan will be brought back for adoption on June 15. Trustees asked questions and had discussion. This report was informational in nature and no action was taken by the Board at this time.

8.5.1.2. Staff Report: Local Control Accountability Plan 2022-23

Assistant Superintendent Coito presented the District’s Local Control Accountability Plan. The Local Control Accountability Plan describes what the District plans to do to support, increase and improve services for students; shows how the District supports all students, especially students that are low income, foster youth, and English learners; and is built around 10 priority areas. Each year the Local Control Accountability Plan process include an analysis of metrics and data, the gathering of stakeholder input and the updating of goals, actions, and services. The Local Control Accountability Plan will be presented to the Board at the June 15 meeting for final approval. Trustees asked questions and had discussion. This report was informational in nature and no action was taken by the Board at this time.

8.5.1.3. PUBLIC HEARING: Local Control Accountability Plan 2022-23

Assistant Superintendent Coito reported the Local Control Accountability Plan provides details regarding the Local Education Agency’s actions and expenditures to support pupil outcomes pursuant to Education Code sections 52060, 52066, 47605, 4760.5, and 47606.5. The public hearing on the 2022-23 Local Control Accountability Plan allows public input prior to being

submitted for adoption at the June 15 Board meeting. After Board adoption, the Local Control Accountability Plan will be submitted to the County Office of Education for final approval.

Open: Board President Tracy-Proulx opened this public hearing at 7:37 p.m.

Comments: None

Closed: Board President Tracy-Proulx closed this public hearing at 7:37 p.m.

8.5.2.1. Staff Report: 2022-23 Preliminary Budget

Assistant Superintendent Monreal provided an overview of the Santa Cruz City Schools 2022-23 Budget assumptions and highlights that included information through the Governor's May Revise of the State Budget. The revenue and expenditure summary included Local Control Funding Formula (LCFF), Federal, State and local revenue, as well as expenditure projections that include employee salaries and benefits, books and supplies, and services and other operating expenses. Multi-year projections were provided, along with Federal and State funding descriptions and other fund highlights. The 2022-23 Budget will return to the Board for final approval on June 15. Trustees asked questions and had discussion. This report was informational in nature and no action was taken by the Board at this time.

8.5.2.2. PUBLIC HEARING: 2022-23 Budget

The Board is required by AB1200 to conduct a public hearing on the 2022-23 Budget to allow for public comment prior to the Board approved the budget. Approval of the Adopted Budget will take place in Open Session at the Regular Meeting on June 15, 2022.

Open: Board President Tracy-Proulx opened this public hearing at 7:58 p.m.

Comments: GSCFT President Casey Carlson asked the board to reevaluate the budget for certificated benefits, as the buffer seemed too large in light of recent changes to certificated benefits for the 22-23 school year.

Closed: Board President Tracy-Proulx closed this public hearing at 8:00 p.m.

8.5.3.1. New Business: Annual Declaration of Need

Assistant Superintendent Parks presented the Annual Declaration of Need for fully qualified educators as a requirement for elementary and secondary schools from the California Commission on Teacher Credentialing. The estimated number listed are not necessarily a determinant of current need, but an educated guess to cover all areas of potential need. Assistant Superintendent Parks recommended approval of this annual declaration of need.

MSP(Coonerty/Vestal) 7-0, the Board of Education approved the Annual Declaration of Need.

8.5.4.1. New Business: Resolution 36-21-22: AB 361

Superintendent Munro presented Resolution 36-21-22. Pursuant to AB 361 and Government Code section 54953, school boards may authorize the use of remote teleconference if meeting in person would present imminent risks to the health or safety of attendees. Superintendent Munro recommended continuing in-person Board meetings with a Zoom option for individuals who prefer to attend remotely and approving Resolution 36-21-22 to allow the Board to return to remote meeting if needed for the health and safety of attendees.

Trustee Threet motioned to approved Superintendent Munro's recommendation. Trustee Coonerty seconded the motion.

MSP(Threet/Coonerty) 7-0, the Board of Education approved Resolution 36-21-22: AB 361.

8.5.4.2. Board Policies: First and/or Final Reading for CSBA Revisions & Updates

Policies are submitted through the GAMUT online board policy book updating process, which uses CSBA recommendations for review and change approximately six times per year in participating districts. These recommendations reflect recent changes in education code and/or case law. The policies have been reviewed by staff to ensure that any required customization for Santa Cruz City Schools has been included.

Trustee Threet motioned to bring the board policies back for a second reading. Trustee Coonerty seconded the motion.

MSP(Threet/Coonerty) 7-0, the Board of Education approved the motion for a first reading of the Board Policies: CSBA Revisions and Updates.

8.5.5.2. Potential Items for Futures Agenda

None.

9. Adjournment of Meeting

As there was no further business to come before the Board of Education, Board President Tracy-Proulx adjourned this Regular Meeting at 8:08 p.m.

Board Meeting Schedule Information

1. The Regular Meeting on June 1, 2022, 6:30 p.m., at the Santa Cruz County Office of Education, and will be broadcast to the public remotely via Zoom.
2. The Regular Meeting on June 8, 2022, 6:30 p.m., at the Santa Cruz County Office of Education, and will be broadcast to the public remotely via Zoom.
3. The Regular Meeting on June 15, 2021, 6:30 p.m., at the Santa Cruz County Office of Education, and will be broadcast to the public remotely via Zoom.

*For more details about this meeting, please visit our district website and listen to the meeting recording:

http://sccs.net/board_of_education

Respectfully submitted,

Kris Munro, Superintendent
Santa Cruz City Schools

Deb Tracy-Proulx, President
Board of Education

**MINUTES OF THE REGULAR MEETING
OF THE SANTA CRUZ CITY SCHOOLS BOARD OF EDUCATION
FOR THE ELEMENTARY AND SECONDARY DISTRICTS
JUNE 8, 2022**

Convene Closed Session

Board President Tracy-Proulx called this Closed Session Meeting to order at 5:30 p.m.

Public Comments for Closed Session Agenda Items

GSCFT President Casey Carlson addressed the Board and acknowledged that the union's ask for a wage increase is higher than the COLA, but shared contextual information from wage increases from neighboring districts.

SCCCE President Jeanie Brown addressed the board to advocate for the wage increase. She acknowledged that the District is not responsible for the inflation rates, but advocated that employees still need a livable wage and approving the wage increase would show appreciation and support for classified employees.

Closed Session Items

Report of Actions Taken in Closed Session

Vice President Owen reported the following actions during closed session:

1. Ms. Parks provided an update to and received direction from Trustees regarding negotiations with the GSCFT.
2. Ms. Parks provided an update to and received direction from Trustees regarding negotiations with the SCCCE.
3. Ms. Parks provided an update to and received direction from Trustees regarding negotiations with Meet & Confer: SCCS Association of Managers and Administrators.
4. Ms. Parks provided an update to and received direction from Trustees regarding negotiations with Meet & Confer: SCCS Confidential Unit.
5. Ms. Munro provided an update to and received direction from Trustees regarding negotiations with Meet & Confer: Non-represented Assistant Superintendents.

Board Meeting Schedule Information

1. The Regular Meeting on June 8, 2022, 6:30 p.m., at the Santa Cruz County Office of Education, and will be broadcast to the public remotely via Zoom.
2. The Regular Meeting on June 15, 2022, 6:30 p.m., at the Santa Cruz County Office of Education, and will be broadcast to the public remotely via Zoom.
3. The Special Meeting on June 22, 2022, 6:30 p.m., at the Santa Cruz County Office of Education, and will be broadcast to the public remotely via Zoom.

*For more details about this meeting, please visit our district website and listen to the meeting recording:
http://sccs.net/board_of_education

Respectfully submitted,

Kris Munro, Superintendent
Santa Cruz City Schools

Deb Tracy-Proulx, President
Board of Education

**MINUTES OF THE REGULAR MEETING
OF THE SANTA CRUZ CITY SCHOOLS BOARD OF EDUCATION
FOR THE ELEMENTARY AND SECONDARY DISTRICTS
JUNE 15, 2022**

Convene Closed Session

Board President Tracy-Proulx called this Closed Session Meeting to order at 5:35 p.m.

Public Comments for Closed Session Agenda Items

Matt Bruner thanked the Board and staff for a positive session of negotiations. Mr. Bruner also thanked the Board for their consideration of the compensation request, and asked they also consider a one-time bonus for staff, as the past year has been very challenging.

Convene Open Session

Board President Tracy-Proulx called this Regular Meeting Open Session to order at 6:35 p.m.

Attendance at Meeting

Sheila Coonerty	John Owen	Cindy Ranii
Jeremy Shonick	Deb Tracy-Proulx	Claudia Vestal

Student Board Representative Destiny Silva
Student Board Representative Laura Wang

Kris Munro, Superintendent
Dorothy Coito, Assistant Superintendent, Educational Services
Jim Monreal, Assistant Superintendent, Business Services
Molly Parks, Assistant Superintendent, Human Resources
Members of the Audience

Absent: Board Representative Patricia Threet

Welcome and Format

Board President Tracy-Proulx welcomed those in attendance and explained the format used for this Regular Meeting of the Board of Education. She thanked attendees for their flexibility in moving to a virtual meeting in response to the recent increase in COVID cases in the community.

3.2. Agenda Changes, Additions, or Deletions & Announcements

None.

PUBLIC COMMENTS

None.

SUPERINTENDENT'S REPORT

Recognition of Student Trustees

Superintendent Munro thanked and recognized Student Trustees Laura Wang and Destiny Silva for their service on the Board of Education during the 2021-22 school year.

Superintendent's Report

Superintendent Munro provided recent data around COVID cases and exposures in the community. Inspire Diagnostics will provide voluntary testing two times per week during summer school. A vaccine clinic was hosted on June 4 which also included optional surveillance testing and drive through symptomatic testing. The District has also submitted a request to the State for additional home test kits. Superintendent Munro and Vice President Owen hosted an orientation for new student trustees. Summer school began on June 7 and over 500 elementary and secondary students are enrolled. The District received another Computer Science for All Grant. Administrator participated in principal data conversation and the Leadership team had their year-end retreat on June 9. Superintendent Munro helped facilitate a planning day for Branciforte Small Schools leadership. The finance team is actively updating site budget spreadsheets for 22-23, while also closing the books for the 21-22 fiscal year. Superintendent Munro met with the Santa Cruz Education Foundation and attended Delta's Board Meeting on June 14.

Students' Report

Student Board Representative Laura Wang did not have a report to share.

Student Board Representative Destiny Silva did not have a report to share.

BOARD MEMBERS' REPORTS

Board Members' Reports

Trustee Vestal thanked the student board representatives for their service during the 21-22 school year.

Trustee Coonerty did not have a report to share.

Trustee Shonick did not have a report to share.

Trustee Ranii also thanked the student board representatives for their service throughout the school year.

Vice President Owen did not have a report to share.

Board President's Report

Board President Tracy-Proulx did not have a report to share.

APPROVAL OF MINUTES

None.

GENERAL PUBLIC BUSINESS

Consent Agenda

8.1.1.1. Out of State Travel Request, 8.1.1.2. Fourth Quarter Williams Report, 8.1.2. Business Services, 8.1.2.1. Purchase Orders, Bids, & Quotes, 8.1.2.2. Warrant Register, 8.1.2.3. Budget Transfers, 8.1.2.4. Disposition of

Surplus Property, 8.1.2.5. Green School Committee Annual Report, 8.1.2.6. Bond Project Notice of Completion, 8.1.3.1. Personnel Actions—Certificated, 8.1.3.2. Personnel Actions—Classified, 8.1.3.3. New Classified Salary Schedule: Athletic Trainer, 8.2.1.1. Read 180 Subscription Renewal, 8.2.1.2. Consultant Services Agreement: WestEd Professional Development, 8.2.1.3. CodeHS Annual Curriculum Purchase, 8.2.1.4. Curriculum Associates Contract Renewal: iReady – Secondary, 8.2.1.5. Memorandum of Understanding: Riverside County Office of Education: Measuring Student Learning, 8.2.1.6. MyLexia Contract Renewal, 8.2.1.7. Document Tracking Services License Renewal, 8.2.1.8. Memorandum of Understanding: Silicon Valley Education Foundation – Elevate Math, 8.2.1.9. Consultant Services Agreement: MIRJ Services, 8.2.1.10. Contract: Blackboard Messenger, 8.2.1.11. Infinite Campus Contract Renewal, 8.2.2.1. School Services of California Agreement Renewal: Fiscal Budget Services 2022-23, 8.2.2.2. Sycamore Farms Livestock Agreement, 8.2.3.1. Contract Addendum: Superintendent, 8.2.3.2. Contract Addendums: Assistant Superintendents, 8.2.4.1. Annual Agreement: California School Boards Association 2022-23 Membership, 8.2.4.2. Annual Agreement: California School Boards Association 2022-23 Online Board Book and Policy Manual Maintenance, 8.3.1 Albion Environmental Proposal: Santa Cruz High School C & D Modernization Construction Oversight Services, 8.3.2. CRW Industries Change Order #5: Santa Cruz High School Switchgear Replacement, 8.3.3. Dilbeck & Sons Inc. Change Order #1: Westlake Elementary School Interactive Touch Panel and White Board Installation, 8.3.4. Kent Construction Change Order #1 for Transportation Yard Site Work, 8.3.5. M3 Environmental Proposal: Santa Cruz High School C & D Modernization Abatement Oversight Services, 8.3.6. MBC Enterprises Inc. Change Order #3: Santa Cruz High School Underground Utility Replacement, 8.3.7. Moore Twining Proposal: Palm Street Maintenance Yard Inspection Services, 8.3.8. Nextperts Proposal: Bay View Elementary and Gault Elementary School Door Hardware Installation, 8.3.9. PSR Electric Proposal: Bay View Elementary School Portable Classroom Electrical, 8.3.10. PSR Electric Proposal: DeLaveaga Elementary School Portable Classroom Electrical, 8.3.11. Ross Recreation Proposal: Bay View Elementary School Ball Wall, 8.3.12. Santa Clara Valley Construction Inspections Proposal: Santa Cruz High School Commons Modernization, 8.3.13. CDW-G Quote Branciforte Middle School Interactive Touch Panel, 8.3.14. CDW-G Quote Mission Hill Middle School Interactive Touch Panel

Trustee Coonerty motioned to approve the consent agenda. Trustee Ranii seconded the motion.

The motion was passed by the following roll call vote:

Roll Call Vote:

Coonerty – Yes	Owen – Yes	Ranii – Yes	
Shonick – Yes	Threet – Absent	Tracy-Proulx – Yes	Vestal – Yes

Closed Session Items

Report of Actions Taken in Closed Session

Vice President Owen reported the following actions during closed session:

1. Ms. Parks shared information with the Board on Certificated/Classified/Management Leaves, Retirements, Resignations & Appointments.
2. Ms. Parks did not have information to share regarding Public Employee Discipline/Dismissal/Release/Complaints
3. Ms. Parks provided an update to and received direction from Trustees regarding negotiations with the GSCFT.
4. Ms. Parks provided an update to and received direction from Trustees regarding negotiations with the SCCCE.

The Board will return to closed session to discuss:

1. Negotiations with Meet & Confer: SCCS Association of Managers and Administrators.
2. Negotiations with Meet & Confer: SCCS Confidential Unit.
3. Negotiations with Meet & Confer: Non-represented Assistant Superintendents.
4. Public employee performance evaluation (Govt. Code Section 5497) – Superintendent 2022-23 Goals.

ITEMS TO BE TRANSACTED AND/OR DISCUSSED

8.5.1.1. New Business: Single Plans for Student Achievement

Assistant Superintendent Coito presented the 2022-23 Single Plans for Student Achievement. Pursuant to California Education Code Section 64001 and the federal Elementary and Secondary Education Act, schools that receive state and federal funds will consolidate all school plans into the Single Plan for Student Achievement. The Single Plan for Student Achievement is a blueprint to improve the academic performance of all students. The purpose of the Single Plan for Student Achievement is to coordinate all educational services at the school. The Single Plan for Student Achievement addresses how funds provided to the school will be used to improve the academic performance of all pupils. Trustees asked questions and had discussion.

Trustee Vestal motioned to approve the 22-23 Single Plans for Student Achievement. Trustee Coonerty seconded the motion.

MSP(Vestal/Coonerty) 6-0, the Board of Education approved the 22-23 Single Plans for Student Achievement.

8.5.1.2 New Business: English Learner Master Plan Adoption

Elementary Director of Curriculum and Instruction, Shannon Calden, presented Santa Cruz City Schools' English Learner Master Plan. The plan will serve as a roadmap for the District to improve support and outcomes for Multilingual Learners. Since the first reading on June 1, 2022, Seal of Biliteracy information was added, as well as an updated description of pathways for secondary students. These changes were made based on feedback during the first reading of the plan. Trustees asked questions and had discussion.

MSP(Coonerty/Owen) 6-0, the Board of Education adopted the English Learner Master Plan.

8.5.1.3. Staff Report: Local Control Accountability Plan Local Indicators

Assistant Superintendent Coito presented the Local Control Accountability Plan Local Indicators. Local Education Agencies are required to annually measure its progress in meeting requirements of the specific LCFF priority, report the results at a regularly scheduled meeting in conjunction with the adoption of the Local Control Accountability Plan, and report the results to the public through the Dashboard utilizing the State Board of Education-adopted self-reflection tools for each local indicator. The local indicators include basic conditions at school, implementation of State Academic Standards, parent and family engagement, school climate, and access to a broad course of study. Santa Cruz City Schools has compiled evidence to substantiate meeting the criteria for each indicator including site facility inspection tool reports, implementation of local assessments, evaluation of instructional materials, master schedule offerings, completion of Social Emotional Health surveys, and calendared family webinars and meetings throughout the 22-23 school year. This report was informational in nature and no action was taken by the Board at this time.

8.5.1.4. New Business: Local Control Accountability Plan 2022-23 Adoption

Assistant Superintendent Coito brought the 2022-23 Local Control Accountability Plan to the Board for final approval. The Local Control Accountability Plan was presented to Trustees on June 1, 2022, and a Public Hearing was held to provide an opportunity for the public to comment on the plan prior to approval. Ms. Coito reviewed updates to the plan from the first reading.

MSP(Cooney/Vestal) 6-0, the Board of Education adopted the 2022-23 Local Control Accountability Plan.

8.5.1.5. Staff Report: Transitional Kindergarten Planning Grant Update

Director of Elementary Curriculum and Instruction Calden presented the Transitional Kindergarten Planning Update. Districts will begin implementation of Universal Prekindergarten in 22-23. The State required a list of questions to be answered in a survey, as well as a presentation to the Board, about the Universal Prekindergarten requirements. There are five areas under consideration in the questions which include Vision and Coherence, Community Engagement and Partnerships, Workforce Recruitment and Professional Learning, Curriculum, Intervention and Assessment, and Facilities, Services, and Operations. Trustees asked questions and had discussion. This report was informational in nature and no action was taken by the Board at this time.

8.5.2.1. New Business: 2022-23 Budget Adoption

Assistant Superintendent Monreal presented the 2022-23 budget for adoption. A Public Hearing was held on June 1, 2022, to provide the public opportunity to comment on the proposed budget prior to approval. Mr. Monreal reviewed the budget development process, shared district revenues and expenditures, and an update to the State Budget after the governor's May Revise. Mr. Monreal recommended approval of the 2022-23 Budget Adoption.

MSP(Owen/Ranii) 6-0, the Board of Education approved the 2022-23 Budget.

8.5.2.2. Staff Report: Bond Budget Update

Assistant Superintendent Monreal presented the Bond Budget Update. Each quarter staff presents an update on Bond expenditures and the projected budget for the fiscal year. This report reflects Bond expenditures through May 31, 2022. This report was informational in nature and no action was taken by the Board at this time.

8.5.2.3. New Business: Resolution 40-21-22: Education Protection Account Spending Plan for 2022-23

Assistant Superintendent Monreal brought forward the annual resolution to determine how monies received from the Education Protection Account will be spent by the District. Mr. Monreal explained that these funds are taken directly from the Local Control Funding Formula (LCFF). The District's intends for these monies to go to teacher salaries. Assistant Superintendent Monreal recommended approval of Resolution 40-21-22.

MSP(Cooney/Owen) 6-0, the Board of Education approved Resolution 40-21-22: Education Protection Account Spending Plan for 2022-23.

Trustee Shonick left the board meeting at 7:28 p.m.

8.5.2.4. New Business: Resolution 41-21-22: Commitment of Funds

Assistant Superintendent presented Resolution 41-21-22. The Governmental Accounting Standards Board adopted Statement Number 54 (GASB 54), which allows districts to commit funds to be fiscally prudent and dedicated to prepare for economic uncertainties. The fund balance measures the net financial resources available to finance expenditures in future periods and will be maintained to provide the District with sufficient working capital to address future spending needs. Assistant Superintendent Monreal recommended approval of this resolution.

MSP(Cooney/Owen) 5-0, the Board of Education approved Resolution 41-21-22: Commitment of Funds.

8.5.2.5. New Business: Resolution 37-21-22: Summer Contract Approvals by Cabinet

Assistant Superintendent Monreal brought forward the annual resolution that authorizes the Superintendent, the Assistant Superintendent of Business Services, and the Director of Finance to award bids from June 22, 2022, through August 17, 2022. This resolution is presented each year in school districts across California as a prudent measure, should unforeseen conditions or an emergency arise, which may cause delay of projects or jeopardize the start of school.

MSP(Ranii/Owen) 5-0, the Board of Education approved Resolution 37-21-22: Summer Contract Approvals by Cabinet.

8.5.3.1. New Business: Resolution 38-21-22: Summer Personnel Actions

Assistant Superintendent Parks brought forward the annual resolution that authorizes the Superintendent to approve routine certificated and classified personnel action items between June 22, 2022, and August 17, 2022.

MSP(Ranii/Vestal) 5-0, the Board of Education approved Resolution 38-21-22: Summer Personnel Actions.

8.5.4.1. New Business: Resolution 39-21-22: 2022 Trustee Elections

Superintendent Munro presented Resolution 39-21-22 to meet the requirements for the Board of Trustees election and requests the County Elections Board to conduct the election and consolidate it with General Election on November 8, 2022. This resolution defines the specification of the election order listing the number of seats being vacated, areas represented, length of term, responsibility of cost for the Candidate's Statement of Qualification and the length of the statement.

Trustee Ranii motioned to approved Resolution 39-21-22, provided staff correct the resolution to reflect that Candidates pay for their Statement of Qualifications, prior to submitting to the County Clerk's office. Vice President Owen seconded the motion.

MSP(Ranii/Owen) 5-0, the Board of Education approved Resolution 39-21-22: 2022 Trustee Elections.

8.5.4.2. Board Policies: Second and/or Final Reading for CSBA Revisions & Updates

Policies are submitted through the GAMUT online board policy book updating process, which uses CSBA recommendations for review and change approximately six times per year in

participating districts. These recommendations reflect recent changes in education code and/or case law. The policies have been reviewed by staff to ensure that any required customization for Santa Cruz City Schools has been included.

MSP(Owen/Ranii) 5-0, the Board of Education approved the CSBA Board Policy Revisions and Updates.

8.5.4.3. Potential Items for Futures Agenda

None.

9. Adjournment of Meeting

As there was no further business to come before the Board of Education, Board President Tracy-Proulx adjourned this Regular Meeting at 7:34 p.m.

10. Return to Closed Session

Board President Tracy-Proulx called this Closed Session Meeting to order at 7:34 p.m.

11. Closed Session Action Report

Vice President Owen reported the following actions during closed session:

1. Ms. Parks provided an update to and received direction from Trustees regarding negotiations with Meet & Confer: SCCS Association of Managers and Administrators.
2. Ms. Parks provided an update to and received direction from Trustees regarding negotiations with Meet & Confer: SCCS Confidential Unit.
3. Ms. Parks provided an update to and received direction from Trustees regarding negotiations with Meet & Confer: Non-represented Assistant Superintendents.
4. The Board discussed public employee performance evaluation (Govt. Code Section 5497) – Superintendent 2022-23 Goals.

12. Adjournment of Meeting

As there was no further business to come before the Board of Education, Board President Tracy-Proulx adjourned this Regular Meeting at 7:57 p.m.

Board Meeting Schedule Information

1. The Regular Meeting on June 15, 2022, 6:30 p.m., will be a remote Zoom Board Meeting.
2. The Special Meeting on June 22, 2022, 6:30 p.m., will be a remote Zoom Board Meeting.

*For more details about this meeting, please visit our district website and listen to the meeting recording: http://sccs.net/board_of_education

Respectfully submitted,

Kris Munro, Superintendent
Santa Cruz City Schools

Deb Tracy-Proulx, President
Board of Education

**MINUTES OF THE SPECIAL MEETING
OF THE SANTA CRUZ CITY SCHOOLS BOARD OF EDUCATION
FOR THE ELEMENTARY AND SECONDARY DISTRICTS
JUNE 22, 2022**

Convene Closed Session

Board President Tracy-Proulx called this Closed Session Meeting to order at 5:30 p.m.

Public Comments for Closed Session Agenda Items

None.

Convene Open Session

Board President Tracy-Proulx called this Regular Meeting Open Session to order at 6:33 p.m.

Attendance at Meeting

Sheila Coonerty	John Owen	Cindy Ranii
Deb Tracy-Proulx	Claudia Vestal	

Kris Munro, Superintendent
Dorothy Coito, Assistant Superintendent, Educational Services
Jim Monreal, Assistant Superintendent, Business Services
Members of the Audience

Absent: Board Representative Patricia Threet
Board Representative Jeremy Shonick
Molly Parks, Assistant Superintendent, Human Resources
Student Board Representative Destiny Silva
Student Board Representative Laura Wang

Welcome and Format

Board President Tracy-Proulx welcomed those in attendance and explained the format used for this Special Meeting of the Board of Education.

3.2. Agenda Changes, Additions, or Deletions & Announcements

None.

PUBLIC COMMENTS

None.

GENERAL PUBLIC BUSINESS

Consent Agenda

5.1.1.1. Nonpublic Agency: Balance Santa Cruz County, 5.1.1.2. Nonpublic Agency: Easter Seals, 5.1.1.3. Nonpublic Agency: ABRITE, 5.1.1.4. Nonpublic Agency: Speechrighter, Inc., 5.1.1.5. Nonpublic School: BRITE Horizons, 5.1.1.6. Nonpublic School: Chartwell, 5.1.1.7. Out of State Residential Treatment Center: Solstice West, 5.1.1.8. Agreement for Professional Services: Margaret Barker, 5.1.1.9. Agreement for Professional Services: Maria Ballard, 5.1.1.10. Contract: Catapult EMS, 8.1.2.1. Cooperative Contract: Postage Meter Lease Agreement

Trustee Ranii motioned to approve the consent agenda. Trustee Vestal seconded the motion.

The motion was passed by the following roll call vote:

Roll Call Vote:

Coonerty – Yes Owen – Yes Ranii – Yes
Shonick – Absent Threet – Absent Tracy-Proulx – Yes Vestal – Yes

Closed Session Items

Report of Actions Taken in Closed Session

Vice President Owen reported the following actions during closed session:

1. Ms. Coito provided trustees with information regarding student expulsion #07-21-22
2. Ms. Coito provided trustees with information regarding student expulsion #08-21-22
3. Ms. Munro shared information with the Board on Certificated/Classified/Management Leaves, Retirements, Resignations & Appointments.
4. Ms. Munro did not have information to share regarding Public Employee Discipline/Dismissal/Release/Complaints

Vote on Student Expulsion #07-21-22

Trustee Ranii motioned to accept the District’s recommendation and expel student #07-21-22. Vice President Owen seconded the motion.

MSP(Ranii/Owen) 5-0, the Board of Education voted to expel student #07-21-22.

Vote on Student Expulsion #08-21-22

Trustee Ranii motioned to accept the District’s recommendation and expel student #08-21-22. Trustee Vestal seconded the motion.

MSP(Ranii/Vestal) 5-0, the Board of Education voted to expel student #08-21-22.

ITEMS TO BE TRANSACTED AND/OR DISCUSSED

5.3.2.1. Staff Report: Facilities Master Plan Update

Assistant Superintendent Monreal introduced consultant Gary Gery and his team, to present the Facilities Master Plan Draft. District staff and administration sought stakeholder engagement through school site community meetings, webinars for the elementary and secondary districts, and a community input form. All input informed the Facilities Master Plan Update Draft. Mr. Gery and his team demonstrated how to navigate the Facilities Master Plan as it is an interactive, web-based document. Community members can give input on the Master

Plan Draft, and a revised plan will be brought to the Board in August 2022. Trustees asked questions and had discussion. This report was informational in nature and no action was taken by the Board at this time.

5.3.4.1. New Business: Resolution 42-21-22: 2022 Bond Measure Elections for Elementary District

Superintendent Munro presented Resolution 42-21-22 to meet the requirements for the Bond Measure Election and requests the County Elections Board to conduct the election and consolidate it with General Election on November 8, 2022. The resolution includes supporting documents that provides the full text of the Ballot Proposition.

MSP(Ranii/Coonerty) 5-0, the Board of Education approved Resolution 42-21-22: 2022 Bond Measure Elections for Elementary District.

5.3.4.2. New Business: Resolution 43-21-22: 2022 Bond Measure Elections for Secondary District

Superintendent Munro presented Resolution 43-21-22 to meet the requirements for the Bond Measure Election and requests the County Elections Board to conduct the election and consolidate it with General Election on November 8, 2022. The resolution includes supporting documents that provides the full text of the Ballot Proposition.

MSP(Coonerty/Vestal) 5-0, the Board of Education approved Resolution 43-21-22: 2022 Bond Measure Elections for Secondary District.

5.3.4.3. New Business: Resolution 44-21-22: AB 361

Superintendent Munro presented Resolution 44-21-22. Pursuant to AB 361 and Government Code section 54953, school boards may authorize the use of remote teleconference if meeting in person would present imminent risks to the health or safety of attendees. Superintendent Munro recommended continuing in-person Board meetings with a Zoom option for individuals who prefer to attend remotely. Approving Resolution 44-21-22 would allow the Board to return to remote meetings if needed for the health and safety of attendees.

MSP(Coonerty/Owen) 5-0, the Board of Education approved Resolution 44-21-22: AB 361.

9. Adjournment of Meeting

As there was no further business to come before the Board of Education, Board President Tracy-Proulx adjourned this Special Meeting at 7:35 p.m.

Board Meeting Schedule Information

1. The Special Meeting on June 22, 2022, 6:30 p.m., will be a remote Zoom Board Meeting.

*For more details about this meeting, please visit our district website and listen to the meeting recording: http://sccs.net/board_of_education

Respectfully submitted,

Kris Munro, Superintendent

Deb Tracy-Proulx, President

SANTA CRUZ CITY SCHOOL DISTRICT

AGENDA ITEM: Williams Uniform Complaint 4th Quarterly Report

MEETING DATE: August 17, 2022

FROM: Dorothy Coito, Assistant Superintendent of Educational Services

THROUGH: Kris Munro, Superintendent

RECOMMENDATION:

Approve the Williams Uniform Complaint 4th Quarterly Report for 2021-22.

BACKGROUND:

According to Education Code and the District’s Administrative Regulation on the Williams Uniform Complaint Policy, school districts must submit quarterly reports to the County Office of Education of all complaints filed in the areas of insufficient instructional materials, teacher vacancy or misassignment, and inadequate facilities.

Upon contacting each school site, it has been verified that there have been no complaints for the fourth quarter of the school year, which ended June 30, 2022. The accompanying report has been created to show that the district did not receive any complaints this quarter.

FISCAL IMPACT:

None

This work is done in support of the following district goals and their corresponding metrics:

Goal #1: All SCCS students will be prepared to successfully access post-secondary college and career opportunities.

Goal #5: SCCS will maintain a balanced budget and efficient and effective management.

Goal #6: SCCS will maintain strong communication and partnerships with its diverse community.

**QUARTERLY DISTRICT STATUS REPORT OF UNIFORM COMPLAINTS
TO THE COUNTY SUPERINTENDENT OF SCHOOLS
QUARTER END June 30, 2022**

DISTRICT: Santa Cruz City Schools

Date Reported to District Governing Board: August 17, 2022

I. INSTRUCTIONAL MATERIALS

A) Insufficient text books or instructional materials in classroom:

# of Complaints 0	# of Complaints Resolved 0	# of Complaints Unresolved* 0
-----------------------------	--------------------------------------	---

*Explanation: _____

B) Insufficient textbooks or instructional materials to take home:

# of Complaints 0	# of Complaints Resolved 0	# of Complaints Unresolved* 0
-----------------------------	--------------------------------------	---

*Explanation: _____

C) Textbooks or instructional materials in poor or unusable condition:

# of Complaints 0	# of Complaints Resolved 0	# of Complaints Unresolved* 0
-----------------------------	--------------------------------------	---

*Explanation: _____

II. TEACHER VACANCY OR MISASSIGNMENT

A) No assigned certified teacher at beginning of semester:

# of Complaints 0	# of Complaints Resolved 0	# of Complaints Unresolved* 0
-----------------------------	--------------------------------------	---

*Explanation: _____

**B) Teacher lacking credentials or training to teach English Language Learners (ELL) with
More than 20% ELL in class:**

# of Complaints 0	# of Complaints Resolved 0	# of Complaints Unresolved* 0
-----------------------------	--------------------------------------	---

*Explanation: _____

C) Teacher instructing class lacking subject matter competency:

# of Complaints 0	# of Complaints Resolved 0	# of Complaints Unresolved* 0
-----------------------------	--------------------------------------	---

*Explanation: _____

III. FACILITIES

A) Conditions posing an emergency or urgent threat to the health or safety of students/staff:

# of Complaints 0	# of Complaints Resolved 0	# of Complaints Unresolved* 0
-----------------------------	--------------------------------------	---

*Explanation: _____

SANTA CRUZ CITY SCHOOL DISTRICT

AGENDA ITEM: PE Waiver – Santa Cruz High School

MEETING DATE: August 17, 2022

FROM: Dorothy Coito, Assistant Superintendent of Educational Services

THROUGH: Kris Munro, Superintendent

RECOMMENDATION:

Approve a Physical Education Requirement Waiver for a student at Santa Cruz High School who cannot participate in Physical Education.

BACKGROUND:

A Santa Cruz High School senior with a history of multiple hip surgeries continues to have hip weakness, tightness, and pain. Her doctor feels it would be detrimental to her health, as well as her academic success if she were to participate in a physical education class. For these reasons, Santa Cruz High School requests the board to waive 20 credits of physical education for this student.

This work is in direct support of the following District goals and their corresponding metrics:

Goal #1: All Santa Cruz City Schools students will be prepared to successfully access post-secondary college and career opportunities.

Goal #2: SCCS will create positive, engaging school environments that promote the development of cognitive skills and the social emotional well-being of all students.

Goal #6: SCCS will maintain strong communication and partnership with its diverse community.

AGENDA ITEM: 8.1.1.2.



SANTA CRUZ HIGH SCHOOL



Santa Cruz City Schools District

415 Walnut Avenue • Santa Cruz, CA 95060
Phone: (831) 429-3960 Fax: (831) 429-3944 Website: schs.sccs.net

Rishi Lal, Assistant Principal

Michelle Poirier, Principal

Rene Ohana, Assistant Principal

July 28, 2022

Dear School Board Members,

Santa Cruz High School is requesting that you waive 20 credits of the Physical Education graduation requirement for [REDACTED]. In a letter dated 6/2/21, their doctor, [REDACTED] states that [REDACTED] has undergone multiple hip surgeries and continues to experience pain and tightness. We are requesting the board to waive 20 credits of physical education based on the state Education Code.

51241. (a) The governing board of a school district or the office of the county superintendent of schools of a county may grant a temporary exemption to a pupil from courses in physical education if the pupil is one of the following:

(1) Ill or injured and a modified program to meet the needs of the pupil cannot be provided.

Thank you,

Rene Ohana

Assistant Principal



DATE: June 6, 2022

NAME: [REDACTED]
DOB: [REDACTED]

To Whom it May Concern:

[REDACTED] has been seen and cared for by Dr. [REDACTED] and Dr. [REDACTED]

[REDACTED] has undergone multiple hip surgeries since 2016, last one so far in 2021 and continues to have hip weakness, tightness and pain.

Please excuse her from not being able to participate in her Physical Education classes during her High School years, 2019 to the present, due to the above. We understand that she has taken other courses in lieu of her PE classes.

We ask for your kind understanding to the important request to please excuse her for her non-participation due to her medical condition.

Should you have any questions, concerns, or further inquiries, please do not hesitate to reach out to us.

The child was seen in the clinic today.

Please excuse the patient from school.

We thank you for your cooperation and attention.

Sincerely,

[REDACTED], RN on behalf of Dr. [REDACTED]

SANTA CRUZ CITY SCHOOL DISTRICT

AGENDA ITEM: Annual Application for Title I, Title II, Title III, and Title IV Funding for SCCS Elementary District

MEETING DATE: August 17, 2022

FROM: Dorothy Coito, Assistant Superintendent of Educational Services

THROUGH: Kris Munro, Superintendent

RECOMMENDATION:

Approve the Application for Funding for Title I, Title II, Title III and Title IV funds for SCCS Elementary District.

BACKGROUND:

Every year the District must complete an application for funding for the Title I, Title II, Title III and Title IV funding from the Federal Government. This year, the application has a check box that certifies that the Local Board has approved the Application for Funding.

The application for funding simply requires a checkbox of all funds for which the District would like to receive funding. There is no plan involved with the application. Approving the application allows the District to apply for the funds. Denying the application means there would be no Title funding for the upcoming school year.

FISCAL IMPACT:

Unknown until funds have been granted.

This work is in direct support of the following District goals and their corresponding metrics:

Goal #1: All Santa Cruz City Schools students will be prepared to successfully access post-secondary college and career opportunities.

Goal #2: SCCS will create positive, engaging school environments that promote the development of cognitive skills and the social emotional well-being of all students.

Goal #3: We will eliminate the achievement gaps that currently exist between demographic groups within the SCCS student community.

Goal #4: We will develop a highly collaborative, professional culture focused on supporting effective teaching.

Goal #5: SCCS will maintain a balanced budget and efficient and effective management.

AGENDA ITEM: 8.1.1.3.



CONSOLIDATED APPLICATION AND REPORTING SYSTEM (CARS)

Santa Cruz City Elementary (44 69815 000000)

- Home
- Data Entry Forms
- Certification Preview
- Certify Data
- Reports
- Users
- Contacts
- FAQs

[Data Entry Instructions](#)

2022–23 Application for Funding

Required fields are denoted with an asterisk (*).

Local Governing Board Approval

The local educational agency (LEA) is required to review and receive approval of their Application for Funding selections with their local governing board.

By checking this box the LEA certifies that the Local Board has approved the Application for Funding for the listed fiscal year:

District English Learner Advisory Committee Review

Per Title 5 of the California Code of Regulations Section 11308, if your LEA has more than 50 English learners, then the LEA must establish a District English Learner Advisory Committee (DELAC) which shall review and advise on the development of the application for funding programs that serve English learners.

By checking this box the LEA certifies that parent input has been received from the District English Learner Committee (if applicable) regarding the spending of Title III funds for the listed fiscal year:

Application for Categorical Programs

To receive specific categorical funds for a school year, the LEA must apply for the funds by selecting Yes below. Only the categorical funds that the LEA is eligible to receive are displayed.

* Title I, Part A (Basic Grant): No Yes
ESSA Sec. 1111 et seq.
SACS 3010

* Title II, Part A (Supporting Effective Instruction): No Yes
ESEA Sec. 2104
SACS 4035

* Title III English Learner: No Yes
ESEA Sec. 3102
SACS 4203

* Title III Immigrant: No Yes
ESEA Sec. 3102
SACS 4201

* Title IV, Part A (Student and School Support): No Yes
ESSA Sec. 4101
SACS 4127

SANTA CRUZ CITY SCHOOL DISTRICT

AGENDA ITEM: Annual Application for Title I, Title II, Title III, and Title IV Funding for SCCS Secondary District

MEETING DATE: August 17, 2022

FROM: Dorothy Coito, Assistant Superintendent of Educational Services

THROUGH: Kris Munro, Superintendent

RECOMMENDATION:

Approve the Application for Funding for Title I, Title II, Title III and Title IV funds for SCCS Secondary District.

BACKGROUND:

Every year the District must complete an application for funding for the Title I, Title II, Title III, and Title IV funding from the Federal Government. This year, the application has a check box that certifies that the Local Board has approved the Application for Funding.

The application for funding simply requires a checkbox of all funds for which the District would like to receive funding. There is no plan involved with the application. Approving the application allows the District to apply for the funds. Denying the application means there would be no Title funding for the upcoming school year.

FISCAL IMPACT:

Unknown until funds have been granted.

This work is in direct support of the following District goals and their corresponding metrics:

Goal #1: All Santa Cruz City Schools students will be prepared to successfully access post-secondary college and career opportunities.

Goal #2: SCCS will create positive, engaging school environments that promote the development of cognitive skills and the social emotional well-being of all students.

Goal #3: We will eliminate the achievement gaps that currently exist between demographic groups within the SCCS student community.

Goal #4: We will develop a highly collaborative, professional culture focused on supporting effective teaching.

Goal #5: SCCS will maintain a balanced budget and efficient and effective management.



CONSOLIDATED APPLICATION AND REPORTING SYSTEM (CARS)

Santa Cruz City Elementary (44 69815 000000)

- Home
- Data Entry Forms
- Certification Preview
- Certify Data
- Reports
- Users
- Contacts
- FAQs

[Data Entry Instructions](#)

2022–23 Application for Funding

Required fields are denoted with an asterisk (*).

Local Governing Board Approval

The local educational agency (LEA) is required to review and receive approval of their Application for Funding selections with their local governing board.

By checking this box the LEA certifies that the Local Board has approved the Application for Funding for the listed fiscal year:

District English Learner Advisory Committee Review

Per Title 5 of the California Code of Regulations Section 11308, if your LEA has more than 50 English learners, then the LEA must establish a District English Learner Advisory Committee (DELAC) which shall review and advise on the development of the application for funding programs that serve English learners.

By checking this box the LEA certifies that parent input has been received from the District English Learner Committee (if applicable) regarding the spending of Title III funds for the listed fiscal year:

Application for Categorical Programs

To receive specific categorical funds for a school year, the LEA must apply for the funds by selecting Yes below. Only the categorical funds that the LEA is eligible to receive are displayed.

* Title I, Part A (Basic Grant): No Yes
ESSA Sec. 1111 et seq.
SACS 3010

* Title II, Part A (Supporting Effective Instruction): No Yes
ESEA Sec. 2104
SACS 4035

* Title III English Learner: No Yes
ESEA Sec. 3102
SACS 4203

* Title III Immigrant: No Yes
ESEA Sec. 3102
SACS 4201

* Title IV, Part A (Student and School Support): No Yes
ESSA Sec. 4101
SACS 4127

SANTA CRUZ CITY SCHOOL DISTRICT

AGENDA ITEM: Purchase Orders, Bids and Quotes

MEETING DATE: August 17, 2022

FROM: Jim Monreal, Assistant Superintendent, Business Services

THROUGH: Kris Munro, Superintendent

RECOMMENDATION:

Approve the purchase orders, quotes, bids and proposals from 06/04/2022 through 07/31/2022.

BACKGROUND:

A detailed report is attached, listing purchase orders, quotes and bids that require Board approval prior to release to vendors or ratification within 60 days as allowed by Education Code 17605. Also included for pre-approval are 2021-22 purchase orders which will be entered before the next regular Board meeting for Facility Services, Transportation, Food Services, and Central Purchasing for routine supplies and services.

The following definitions are provided to clarify the differences between purchase orders, quotes and bids:

Purchase Orders:

All purchases shall be made by formal contract or purchase order or shall be accompanied by a receipt. The Superintendent or designee may create a "blanket" or "open" purchase order system for the purchase of minor items as needed from a vendor.

Quotes:

For the purchase of materials and supplies between \$15,000 and \$60,000 more than one quote is required and may be verbal or written. When purchases will be \$15,000 to \$99,100 for contracted work other than Public Works Projects and \$60,000 to \$99,100 for materials and supplies, several vendors are contacted for written quotes/proposals. This process, though not as rigorous as a bid, ensures that the District has involved more than one vendor and will secure a competitive price.

Bids/RFP:

A formal process including advertising to notify prospective bidders, distribution of written specification regarding the work or materials, and compliance with legal guidelines for bidding, must be followed for contracted work other than CUPCCAA Public Works Projects projected to cost \$99,100 and over, or for materials and supplies in the sum of \$99,100 or over unless a Cooperative Purchasing Agreement is being utilized under PCC 20118. Under CUPCCAA contracts may be awarded up to \$60,000 without additional quotes. Informal bidding

AGENDA ITEM: 8.1.2.1.

procedures are followed for Public Works projects from \$60,000 to \$200,000 and a formal bid process occurs for Public Works projects over \$200,000 (PCC 20117(B), 20651(B). Bids are solicited from a wide pool of prospective vendors, thus assuring that when the award is made to the lowest responsible bidder and that the District receives the best price available.

This work is in direct support of the following District goal and its corresponding metrics:

Goal #5: SCCS will maintain a balanced budget and efficient and effective management.

Description

Includes Purchase Orders dated 06/04/2022 - 07/31/2022

PO Number	Vendor Name	Requisition Information	Ordr Loc	Req Fund	Resource Description	Req Fund Order Amt
PO22-01005	APPLE COMPUTER INC	Apple Licenses for Goldfarb	BMS	01	DONATIONS	178.46
PO22-01785	LINCOLN AQUATICS	MOT-OPEN PO 21/22 FOR POOL CHEMICALS	M&O	01	ONGOING & MAJO	29,608.11
PO22-02453	AMAZON CAPITAL SERV	REPLACEMENT BOOKS/RAT DAMAGE	BSS	01	NO REPORTING RI	2,117.01
PO22-02454	HEINEMANN	BOOK REPLACEMENT/RAT REMEDIATION	BSS	01	NO REPORTING RI	1,035.79
PO22-02455	CDW GOVERNMENT INC.	SURFACE PRO, DOCKING STATION	BUSN	01	NO REPORTING RI	2,132.41
PO22-02456	SCHOLASTIC MAGAZINE	CFP SCHOLASTIC MAGAZINES INVOICE M7230231	SPED	01	SE:STATE LOCAL	271.42
PO22-02457	SANTA CRUZ COE	DLV Outdoor Science School	DLEL	01	DONATIONS	23,621.00
PO22-02459	COUNTY OF SANTA CRU	SCHS - SC COUNTY ENVIRONMENTAL HEALTH PERMIT	M&O	01	ONGOING & MAJO	3,373.50
PO22-02460	ANAYA CONSTRUCTION	BV PORTABLE REMOVAL	M&O	21	Bond A Elem	38,800.00
PO22-02461	ATLANTIS PAVING & G	*BV SITE WORK	M&O	21	Bond A Elem	147,899.00
PO22-02463	M3 ENVIRONMENTAL CO	GE PORTABLE OVERSIGHT	M&O	21	Bond A Elem	6,750.00
PO22-02465	AV NOW INC	B40MS AV EQUIP	M&O	21	Bond A Secondar	74,065.01
PO22-02466	PLOW & HEARTH	SAFETY ORDER FOR LIFELAB	BUSN	01	OTHER RESTRICT	127.23
PO22-02467	AMAZON CAPITAL SERV	REPLACEMENT LIBRARY BOOKS/RAT REMEDIATION	BUSN	01	NO REPORTING RI	630.00
PO22-02468	MOBILE MODULAR MGMT	DLEL PORTABLE CLASSROOM REMOVAL (X3)	M&O	25	OTHER RESTRICT	40,976.21
PO22-02470	LUNCHASSIST INC	FS Prof. consulting services April to June 22	FS	13	OTHER RESTRICT	5,000.00
PO22-02471	AMAZON CAPITAL SERV	REPLACEMENT MATERIALS DUE TO RAT INFESTATION	BUSN	01	NO REPORTING RI	3,208.77
PO22-02472	OFFICE DEPOT	REPLACEMENT INST/OFFICE MATLS/RAT REMEDIATION	BUSN	01	NO REPORTING RI	1,423.05
PO22-02473	MARCY COOK DBA MARC	REPLACEMENT MATH MATERIALS/RAT REMEDIATION	BSS	01	NO REPORTING RI	290.64
PO22-02474	POSITIVE DISIPLINE	CSA Positive Discipline Community	STUS	01	ESSER	3,500.00
PO22-02475	LEARNING WITHOUT TE	REPLACEMENT MATLS/RAT REMEDIATION	BUSN	01	NO REPORTING RI	.00
PO22-02476	M3 ENVIRONMENTAL CO	DLEL KINDERGARTEN PORTABLE MICROBIAL INSPECTION	M&O	01	ONGOING & MAJO	1,050.00
PO22-02477	SANTA CRUZ, COUNTY	ELEM Summer Camp - Simpkins Field Trip	CURR	01	ELO ESSERIII LL	532.00
PO22-02478	STAPLES ADVANTAGE	Elementary Summer School - Copy Paper	CURR	01	ELO ESSERIII LL	42.97
PO22-02479	CRW INDUSTRIES INC	SCHS KITCHEN HOOD (RETENTION FEE FROM 2014 JOB)	M&O	01	ONGOING & MAJO	3,270.65
PO22-02480	SANTA CRUZ COE	CFP - Outdoor Science School	WLEL	01	DONATIONS	22,242.00
PO22-02481	MONTANO PLUMBING IN	DLEL EMERGENCY BACKFLOW DEVICE REPLACEMENT	M&O	01	ONGOING & MAJO	5,383.20
PO22-02482	BOSCO CONSTRUCTION	DLV PORTABLE FLOOR REPAIRS	M&O	21	Bond A Elem	10,833.00
PO22-02483	PACIFIC MATERIAL HA	21/22 OPEN PO FOR FORKLIFT MAINTENCE	M&O	01	NO REPORTING RI	450.00

The preceding Purchase Orders have been issued in accordance with the District's Purchasing Policy and authorization of the Board of Trustees. It is recommended that the preceding Purchase Orders be approved and that payment be authorized upon delivery and acceptance of the items ordered.

ESCAPE ONLINE

Description

Includes Purchase Orders dated 06/04/2022 - 07/31/2022

PO Number	Vendor Name	Requisition Information	Ordr Loc	Req Fund	Resource Description	Req Fund Order Amt
PO22-02484	DIVISION OF STATE A	SCH TEMP HOUSING CLOSEOUT	M&O	21	Bond A Secondar	1,614.59
PO22-02486	PSR ELECTRIC	DLV PORTABLE ELECTRICAL	M&O	21	Bond A Elem	15,715.00
PO22-02487	PSR ELECTRIC	BV PORTABLE SAFE OFF	M&O	21	Bond A Elem	26,628.00
PO22-02490	SANTA CLARA VALLEY	SCH C&D MOD INSPECTIONS	M&O	21	Bond A Secondar	333,600.00
PO22-02491	NOURISHING GENERATI	ELEM Summer Camp Nourishing Field Trip	CURR	01	ELO ESSERIII LL	2,000.00
PO22-02492	LEARNING WITHOUT TE	REPLACEMENT MATLS/RAT REMEDIATION	BUSN	01	NO REPORTING RI	1,168.68
PO22-02493	STAPLES ADVANTAGE	Elementary Summer School - Copy Paper	CURR	01	ELO ESSERIII LL	687.49
PO22-02494	SC ROLLER PALLADIUM	Summer Camp field trip - roller palladium	CURR	01	ELO ESSERIII LL	496.00
PO22-02495	SANTA CRUZ COE	S5C 21-22 Membership Fees	SUPT	01	NO REPORTING RI	6,277.00
PO22-02499	BSN SPORTS LLC	CFP SPORTS SUPPLIES	BUSN	01	Measure T	2,303.85
PO22-02500	BSN SPORTS LLC	CFP SPORTS SUPPLIES	BUSN	01	Measure T	1,391.65
PO22-02501	BSN SPORTS LLC	CFP FB DRINKING STATION	BUSN	01	Measure T	564.50
PO22-02502	BSN SPORTS LLC	CFP FB CHAIN SET	BUSN	01	Measure T	562.36
PO22-02503	INFINITE CAMPUS INC	Weighted and Unweighted Academic GPA's Feature	EDSV	01	NO REPORTING RI	.00
PO22-02505	CDW GOVERNMENT INC.	C. Gomez Office	IT	01	NO REPORTING RI	3,247.80
PO22-02508	AMAZON CAPITAL SERV	C. Gomez New Office Items	IT	01	NO REPORTING RI	.00
PO22-02510	ACE PORTABLE SERVIC	CFP - ACE PORTABLE SERVICES FOR BASEBALL	SCHS	01	Measure T	690.00
PO22-02511	CDW GOVERNMENT INC.	PCs for IT Staff	IT	01	NO REPORTING RI	2,630.63
PO22-02512	ALL BAY MECHANICAL	CFP HVAC REPAIRS AT THE D.O.	DO	01	OTHER RESTRICT	675.00
PO22-02513	MILLER MAXFIELD INC	Communications/Consulting	SUPT	01	OTHER RESTRICT	787.50
PO22-02514	FEDEX OFFICE	Freight for MH book return	CURR	01	NO REPORTING RI	1,089.33
PO22-02515	BOARDWALK BOWL	CFP ESY BOWLING AT BOARDWALK BOWLING FOR PE	SPED	01	ELO ESSERIII LL	105.00
PO22-02516	ADVANCED BLIND & SH	MH RM9 RESTRING BLINDS	M&O	01	ONGOING & MAJO	275.00
PO22-02517	DANNIS WOLIVER KELL	Legal Fees	SUPT	01	NO REPORTING RI	472.00
PO22-02519	BARTOS ARCHITECTURE	MASTER PLAN UPDATE	M&O	25	OTHER RESTRICT	50,000.00
PO22-02520	19SIX ARCHITECTS	MASTER PLAN UPDATE	M&O	25	OTHER RESTRICT	50,000.00
PO22-02521	BELLI ARCHITECTURAL	MASTER PLAN UPDATE	M&O	25	OTHER RESTRICT	60,000.00
PO22-02522	SANTA CRUZ COE	Science Camp 2021-2022/Confirm for payment.	GAEL	01	DONATIONS	9,174.00
PO22-02523	ACSA C/O BOXWOOD TE	ACSA Career Center - Inv. 3862728	PERC	01	NO REPORTING RI	288.00
PO22-02524	ACSA	3 EdCal Print Ads	HR	01	NO REPORTING RI	1,436.00
PO22-02525	UCSC-REGENTS	Workstudy	EDSV	01	LCFF SUPP FUNDI	273.00
PO22-02526	SANTA CRUZ COE	CFP - TIER II CREDENTIALING PROGRAM	HR	01	NO REPORTING RI	14,540.00
PO22-02527	SCOTTS VALLEY USD	CTE CLASS 21/22	FIN	01	Measure T	1,000.00
PO23-00004	A-Z BUS SALES INC	Open PO for parts	TRAN	01	TRANSPORT:HOM	2,500.00
PO23-00005	A-Z BUS SALES INC	Open PO for parts	TRAN	01	TRANSPORT:SPEC	2,500.00

The preceding Purchase Orders have been issued in accordance with the District's Purchasing Policy and authorization of the Board of Trustees. It is recommended that the preceding Purchase Orders be approved and that payment be authorized upon delivery and acceptance of the items ordered.

ESCAPE ONLINE

Description

Includes Purchase Orders dated 06/04/2022 - 07/31/2022

PO Number	Vendor Name	Requisition Information	Ordr Loc	Req Fund	Resource Description	Req Fund Order Amt
PO23-00006	ALWAYS TOWING & REC	Open PO for Towing	TRAN	01	TRANSPORT:HOM	500.00
PO23-00007	ALWAYS TOWING & REC	Open PO for Towing	TRAN	01	TRANSPORT:SPEC	250.00
PO23-00008	AUTO ELECTRIC SPECI	Open PO for Repairs	TRAN	01	TRANSPORT:HOM	100.00
PO23-00009	AUTO ELECTRIC SPECI	Open PO for Repairs	TRAN	01	TRANSPORT:SPEC	100.00
PO23-00010	OTTLEY INC DBA BLUE	Open PO for Transportation	TRAN	01	TRANSPORT:HOM	1,000.00
PO23-00011	BUSWEST	Open PO for Parts	TRAN	01	TRANSPORT:HOM	2,500.00
PO23-00012	DOCTORS ON DUTY MED	Open PO for Driver Physicals	TRAN	01	TRANSPORT:HOM	750.00
PO23-00013	EXTREME TOWING	Open PO for Towing	TRAN	01	TRANSPORT:HOM	100.00
PO23-00014	EXTREME TOWING	Open PO for Towing	TRAN	01	TRANSPORT:SPEC	100.00
PO23-00015	ROBERT L IVERS	Open PO for Opacity Tests	TRAN	01	TRANSPORT:HOM	350.00
PO23-00016	ROBERT L IVERS	Open PO for Opacity Tests	TRAN	01	TRANSPORT:SPEC	350.00
PO23-00017	LION ELECTRIC CO US	Open PO for Electric Bus Parts	TRAN	01	TRANSPORT:HOM	2,500.00
PO23-00018	LION ELECTRIC CO US	Open PO for Electric Bus Service	TRAN	01	TRANSPORT:HOM	2,500.00
PO23-00019	LION ELECTRIC CO US	Open PO for Electric Bus Parts	TRAN	01	TRANSPORT:SPEC	500.00
PO23-00020	LION ELECTRIC CO US	Open PO for Electric Bus Service	TRAN	01	TRANSPORT:SPEC	500.00
PO23-00021	WINCHESTER SOQUEL D	Open PO for Bus Parts	TRAN	01	TRANSPORT:SPEC	3,000.00
PO23-00022	NORTH BAY FORD	Open PO for Bus Parts	TRAN	01	TRANSPORT:HOM	200.00
PO23-00023	DIESELWORKS	Open PO for Bus Repairs/Service	TRAN	01	TRANSPORT:HOM	5,000.00
PO23-00024	DIESELWORKS	Open PO for Bus Repairs/Service	TRAN	01	TRANSPORT:SPEC	5,000.00
PO23-00025	FLYERS ENERGY LLC	Open PO for Fuel	TRAN	01	TRANSPORT:HOM	20,000.00
PO23-00026	FLYERS ENERGY LLC	Open PO for Fuel	TRAN	01	TRANSPORT:SPEC	13,000.00
PO23-00027	LUX BUS AMERICA	Open PO for Football Transportation	TRAN	01	NO REPORTING RI	5,000.00
PO23-00028	WINCHESTER SOQUEL D	Open PO for Bus Parts	TRAN	01	TRANSPORT:HOM	5,000.00
PO23-00029	AMAZON CAPITAL SERV	OPEN ORDER SUPPLIES FOR FINANCE/BUSINESS SERVICES	FIN	01	NO REPORTING RI	1,000.00
PO23-00030	OFFICE DEPOT	OPEN ORDER OFFICE SUPPLIES FINANCE	BUSN	01	NO REPORTING RI	500.00
PO23-00031	BRINKS AWARDS & SIG	OPEN ORDER NAME PLATES ETC	DO	01	NO REPORTING RI	200.00
PO23-00032	COSTCO MEMBERSHIP	ANNUAL MEMBERSHIP	BUSN	01	NO REPORTING RI	60.00
PO23-00033	CRUZIO	INTERNET SERVICE	BUSN	01	NO REPORTING RI	660.00
PO23-00034	FEDEX OFFICE	MAILING SERVICES	FIN	01	NO REPORTING RI	100.00
PO23-00035	PALACE BUSINESS SOL	OPEN ORDER/OFFICE SUPPLIES FINANCE/BUSINESS DEPT	BUSN	01	NO REPORTING RI	250.00
PO23-00036	RAY MORGAN CO.	STAPLES FOR COPIERS	BUSN	01	NO REPORTING RI	4,000.00
PO23-00037	SANTA CRUZ SENTINEL	LEGAL ADS	DO	01	NO REPORTING RI	100.00
PO23-00038	UNITED PARCEL SERVI	OPEN ORDER FOR SHIPPING SERVICES	DO	01	NO REPORTING RI	1,200.00
PO23-00039	SCHOOL SERVICES OF	FISCAL BUDGET SERVICES	FIN	01	NO REPORTING RI	4,080.00
PO23-00040	STAPLES ADVANTAGE	OPEN ORDER DO CENTRAL SUPPLY CABINET	FIN	01	NO REPORTING RI	300.00
PO23-00041	STAPLES ADVANTAGE	OPEN ORDER FOR D.O. COPY PAPER	DO	01	NO REPORTING RI	2,000.00
PO23-00042	AMAZON.COM	CUSTODIAL/BREAK ROOM SUPPLIES	DO	01	NO REPORTING RI	400.00

The preceding Purchase Orders have been issued in accordance with the District's Purchasing Policy and authorization of the Board of Trustees. It is recommended that the preceding Purchase Orders be approved and that payment be authorized upon delivery and acceptance of the items ordered.

ESCAPE ONLINE

Description

Includes Purchase Orders dated 06/04/2022 - 07/31/2022

PO Number	Vendor Name	Requisition Information	Ordr Loc	Req Fund	Resource Description	Req Fund Order Amt
PO23-00043	SPURR	SPURR UTILITIES ADULT ED	FIN	11	ADULT ED APPOR	1,300.00
PO23-00044	OFFICE DEPOT	DO CENTRAL OPEN PO OFFICE SUPPLIES	BUSN	01	NO REPORTING RI	750.00
PO23-00045	NORTH BAY FORD	Open PO for Bus Repairs	TRAN	01	TRANSPORT:HOM	3,000.00
PO23-00046	NORTH BAY FORD	Open PO for Bus Repairs	TRAN	01	TRANSPORT:SPEC	3,000.00
PO23-00047	PACIFIC TRUCK PARTS	Open PO for Bus Parts	TRAN	01	TRANSPORT:HOM	2,500.00
PO23-00048	PALACE BUSINESS SOL	Open PO for Office Supplies	TRAN	01	TRANSPORT:HOM	500.00
PO23-00049	PAJARO VALLEY USD	Open PO for Bus Repairs	TRAN	01	TRANSPORT:HOM	500.00
PO23-00050	COAST COUNTIES PETE	Open PO for Bus Repairs	TRAN	01	TRANSPORT:HOM	2,000.00
PO23-00051	COAST COUNTIES PETE	Open PO for Bus Repairs	TRAN	01	TRANSPORT:SPEC	1,000.00
PO23-00052	TRAVIS PRIOR DBA PR	Open PO for Tires	TRAN	01	TRANSPORT:HOM	2,500.00
PO23-00053	TRAVIS PRIOR DBA PR	Open PO for Tires	TRAN	01	TRANSPORT:SPEC	2,500.00
PO23-00054	TRAVIS PRIOR DBA PR	Open PO for Repairs	TRAN	01	TRANSPORT:HOM	500.00
PO23-00055	TRAVIS PRIOR DBA PR	Open PO for Repairs	TRAN	01	TRANSPORT:SPEC	500.00
PO23-00056	SALINAS VALLEY FORD	Open PO for Bus Repairs	TRAN	01	TRANSPORT:HOM	500.00
PO23-00057	SALINAS VALLEY FORD	Open PO for Bus Repairs	TRAN	01	TRANSPORT:SPEC	500.00
PO23-00058	SANTA CRUZ FIRE EQU	Refill Fire Extinguishers	TRAN	01	TRANSPORT:HOM	750.00
PO23-00059	VERTICAL BRIDGE TOW	Tower Space Rent	TRAN	01	TRANSPORT:HOM	3,700.00
PO23-00060	SILKE COMMUNICATION	Open PO for Radios	TRAN	01	TRANSPORT:HOM	2,000.00
PO23-00061	CREATIVE BUS SALES	Open PO for Bus Parts	TRAN	01	TRANSPORT:HOM	500.00
PO23-00062	CREATIVE BUS SALES	Open PO for Bus Parts	TRAN	01	TRANSPORT:SPEC	500.00
PO23-00063	OFFICE DEPOT	Open PO for Office Supplies/Paper	TRAN	01	TRANSPORT:HOM	100.00
PO23-00064	STEVE TORRES MATCO	Open PO for Bus Parts	TRAN	01	TRANSPORT:HOM	1,000.00
PO23-00065	APEX AUTO GLASS	Open PO for Glass Repair	TRAN	01	TRANSPORT:HOM	200.00
PO23-00066	APEX AUTO GLASS	Open PO for Glass Repair	TRAN	01	TRANSPORT:SPEC	200.00
PO23-00067	LANGUAGELINE SOLUTI	CSA: MANDATED TRANSLATION SERVICES	SPED	01	SE:STATE LOCAL	2,289.56
PO23-00068	EDFILES INC	EDFILE SCANNING SERVICE RENEWAL INVOICE 905418	SPED	01	SE:STATE LOCAL	3,955.00
PO23-00069	ROSSI'S TOWING	Open PO for Towing	TRAN	01	TRANSPORT:HOM	300.00
PO23-00070	ROSSI'S TOWING	Open PO for Towing	TRAN	01	TRANSPORT:SPEC	300.00
PO23-00071	US BANK	ESTIMATED ADMIN FEES & INCIDENTALS FOR 22/23, QSCB	BUSN	01	NO REPORTING RI	2,500.00
PO23-00072	AMAZON CAPITAL SERV	OPEN PO TEACHER SUPPLIES	SCHS	01	NO REPORTING RI	500.00
PO23-00073	AMAZON CAPITAL SERV	OPEN PO OFFICE SUPPLIES	SCHS	01	NO REPORTING RI	500.00
PO23-00074	THE LIBRARY STORE I	LIBRARY SUPPLIES	SCHS	01	NO REPORTING RI	838.11
PO23-00075	COMPLETE MAILING SE	MAILING SERVICES	DO	01	NO REPORTING RI	20,000.00
PO23-00076	AT&T	AT&T VOIP/IPFLEX SOLUTION	DO	01	NO REPORTING RI	20,019.60
PO23-00077	SCHOOL INNOVATIONS	program advisory services 22-23	BUSN	01	NO REPORTING RI	16,500.00
PO23-00078	SO PENINSULA REG IN	22-23 SPRIG PREMIUMS	BUSN	01	NO REPORTING RI	733,998.00
PO23-00079	MISSION HILL BLDG O	22-23 ASSOCIATION DUES	FIN	01	NO REPORTING RI	76,000.00
PO23-00080	GS DIRECT LLC	SOLAR UTILITIES	FIN	01	NO REPORTING RI	72,000.00
PO23-00081	SOLARCITY LMC SERIE	SOLAR UTILITIES	FIN	01	NO REPORTING RI	68,000.00

The preceding Purchase Orders have been issued in accordance with the District's Purchasing Policy and authorization of the Board of Trustees. It is recommended that the preceding Purchase Orders be approved and that payment be authorized upon delivery and acceptance of the items ordered.

ESCAPE ONLINE

Description

Includes Purchase Orders dated 06/04/2022 - 07/31/2022

PO Number	Vendor Name	Requisition Information	Ord Loc	Req Fund	Resource Description	Req Fund Order Amt
PO23-00082	SOLAR ENERGY OF AME	SOLAR UTILITIES	FIN	01	NO REPORTING RI	60,000.00
PO23-00083	E.D.D./ STATE OF CA	BLANKET PO FOR SUI PAYMENTS	FIN	01		30,000.00
PO23-00084	MAGNOLIA SUN LLC	SOLAR UTILITIES	FIN	01	NO REPORTING RI	65,000.00
PO23-00085	SANTA CRUZ, CITY OF	UTILITIES - LANDFILL	FIN	01	NO REPORTING RI	6,000.00
PO23-00086	AT&T	ETHERNET NETWORK	DO	01	NO REPORTING RI	13,000.00
PO23-00087	DEPARTMENT OF REHAB	TRANSITION PARTNERSHIP PROGRAM	BUSN	01	SE:STATE LOCAL	78,999.00
PO23-00088	PG&E	PGE - ADULT ED	FIN	11	ADULT ED APPOR	12,500.00
PO23-00089	PG&E	PGE GENERAL FUND	FIN	01	NO REPORTING RI	850,000.00
PO23-00090	PINNACLE PUBLIC FIN	LEASE PURCHASE BUS LEASE	TRAN	01	OTHER RESTRICT	74,044.86
PO23-00091	SANTANDER LEASING L	USED BUSES LEASE TO OWN	TRAN	01	OTHER RESTRICT	13,432.00
PO23-00092	SANTANDER LEASING L	2 NEW BUSES	TRAN	01	OTHER RESTRICT	33,382.00
PO23-00093	ARBITERPAY TRUST AC	SPORTS FEES AND REFS	FIN	01	Measure T	53,000.00
PO23-00094	SAN JOSE CHARTER IN	Open PO for Football Transportation	TRAN	01	NO REPORTING RI	5,000.00
PO23-00095	WILLIAMSON BODY & P	Open PO for Bus Repairs	TRAN	01	TRANSPORT:SPEC	5,000.00
PO23-00096	DISCOVERY CHARTERS	Open PO for Football Transportation	TRAN	01	NO REPORTING RI	5,000.00
PO23-00098	TEACHERS PAY TEACHE	ACCESS SUBSCRIPTION	SCHS	01	NO REPORTING RI	6,200.00
PO23-00099	PLAY IT AGAIN SPORT	OPEN ORDER FOR PLAYGROUND ITEMS	HR	01	NO REPORTING RI	100.00
PO23-00100	DOCTORS ON DUTY MED	OPEN ORDER TB/CDS TESTING	HR	01	NO REPORTING RI	1,500.00
PO23-00101	BIOMETRICS4ALL INC	OPEN ORDER Fingerprinting Service	HR	01	NO REPORTING RI	2,800.00
PO23-00102	CENTRAL DRUG SYSTEM	OPEN ORDER Central Drug Services	HR	01	NO REPORTING RI	1,500.00
PO23-00103	AMERICAN RED CROSS	OPEN ORDER American Red Cross CPR	HR	01	NO REPORTING RI	600.00
PO23-00104	PALACE BUSINESS SOL	OPEN ORDER HR Office Supplies	HR	01	NO REPORTING RI	300.00
PO23-00105	AMAZON.COM	OPEN PO OFFICE SUPPLIES FOR HR	HR	01	NO REPORTING RI	600.00
PO23-00106	JULIANNE GILLASPY	Parent Transportation Reimbursement	TRAN	01	TRANSPORT:SPEC	1,000.00
PO23-00107	PENINSULA SPORTS IN	Open PO for Sports Fees	HHS	01	Measure T	3,000.00
PO23-00108	PACIFIC COAST ATHLE	Open PO for League Fees	HHS	01	Measure T	500.00
PO23-00109	CIF-CALIF INTERSCHO	Open PO for State League Dues	HHS	01	Measure T	800.00
PO23-00110	CIF-CCS	Open PO for Sports Fees	HHS	01	Measure T	4,500.00
PO23-00111	EARLE LAPP	Open PO for Clock Operation	HHS	01	Measure T	600.00
PO23-00112	SANTA CRUZ COUNTY B	Open PO for BB Officials	HHS	01	Measure T	2,500.00
PO23-00113	PALACE BUSINESS SOL	Open PO for Office Supplies	HHS	01	NO REPORTING RI	1,000.00
PO23-00115	SAFEWAY STORES INC	Open PO for Staff Mtgs.	HHS	01	NO REPORTING RI	500.00
PO23-00116	ETR ASSOCIATES INC	HealthSmart	HHS	01	NO REPORTING RI	999.00
PO23-00117	TEXTBOOK WAREHOUSE	Textbooks	HHS	01	NO REPORTING RI	3,025.02
PO23-00118	FOLLETT CONTENT SOL	Woodshop Books	HHS	01	Measure T	1,261.84
PO23-00119	TEXTBOOK WAREHOUSE	Woodshop Workbooks	HHS	01	Measure T	785.62
PO23-00120	P&A ADMINISTRATIVE	Blanket PO for Cobra Administration 22-23	DO	01		2,736.00
PO23-00121	CALIF DOJ ACCTNG CU	OPEN ORDER DOJ Fingerprinting	HR	01	NO REPORTING RI	18,000.00
PO23-00122	KATIE EICHOLZ	Parent Transportation Reimbursement	TRAN	01	TRANSPORT:SPEC	11,000.00

The preceding Purchase Orders have been issued in accordance with the District's Purchasing Policy and authorization of the Board of Trustees. It is recommended that the preceding Purchase Orders be approved and that payment be authorized upon delivery and acceptance of the items ordered.

ESCAPE ONLINE

Page 5 of 19

Description

Includes Purchase Orders dated 06/04/2022 - 07/31/2022

PO Number	Vendor Name	Requisition Information	Ordr Loc	Req Fund	Resource Description	Req Fund Order Amt
PO23-00123	SC COAST ATHLETIC	Open PO for League Dues	HHS	01	Measure T	7,000.00
PO23-00124	MHB VOLLEYBALL CONS	Open PO for Officials/Fees	HHS	01	Measure T	7,000.00
PO23-00125	SANTA CRUZ COUNTY S	Open PO for Soccer Referees	HHS	01	Measure T	6,500.00
PO23-00126	SANTA CRUZ COUNTY B	Open PO for Baseball Umpires	HHS	01	Measure T	7,500.00
PO23-00127	RIDDELL ALL AMERICA	Open PO for Football Reconditioning	HHS	01	NO REPORTING RI	7,500.00
PO23-00128	STAPLES ADVANTAGE	Open PO for Paper/Supplies	HHS	01	NO REPORTING RI	5,000.00
PO23-00129	INTERNATIONAL BACCA	IB Diploma Annual Fee	HHS	01	NO REPORTING RI	11,650.00
PO23-00130	SUTTER HEALTH PLUS	Annual PO 2022/23 School Year	FIN	01		5,144,409.96
PO23-00131	KAISER FOUNDATION H	Annual PO 22/23 School Year	FIN	01		743,859.24
PO23-00132	ACSIG/VSP VISION CA	VSP Vision Coverage Annual PO 2022/23 School Year	FIN	01		80,498.40
PO23-00133	ACSIG/EDGE DENTAL A	Annual PO Dental Coverage 2022/23 School Year	FIN	01		609,837.60
PO23-00134	SISC	Annual PO 2022/23 School Year	FIN	01		6,079,665.60
PO23-00135	HARTFORD LIFE	The Hartford Life Invoices 22/23	BUSN	01		37,040.04
PO23-00136	THE HARTFORD LTD AT	The Hartford Disability FY 22/23	BUSN	01		45,595.20
PO23-00137	TURNITIN LLC	CSA - Software Program	HHS	01	LCFF SUPP FUNDI	4,820.00
PO23-00138	BSN SPORTS LLC	PE Uniforms	HHS	01	LCFF SUPP FUNDI	7,026.42
PO23-00139	REVOLT RECYCLING, L	22/23 OPEN PO FOR LIGHT BULB RECYCLING	M&O	01	ONGOING & MAJO	2,000.00
PO23-00140	RAY MORGAN CO.	ANNUAL COPIER MAINTENANCE	M&O	01	NO REPORTING RI	84,000.00
PO23-00141	BRIGHTLY SOFTWARE I	22/23 ANNUAL LICENSE FEE DISTRICT'S W.O. SOFTWARE	M&O	01	ONGOING & MAJO	7,063.31
PO23-00142	CDW GOVERNMENT INC.	Smartbus	IT	01	NO REPORTING RI	49,260.42
PO23-00143	PALACE BUSINESS SOL	FS Office Supplies	FS	13	CHLD NUTR:SCHO	1,500.00
PO23-00144	OFFICE DEPOT	FS Office Supplies	FS	13	CHLD NUTR:SCHO	1,500.00
PO23-00145	TYPING AGENT LLC	22-23 Typing Agent License Renewal (Elementary)	CURR	01	NO REPORTING RI	2,520.00
PO23-00146	THE ORIGINS PROGRAM	Gateway School SEAL PD	CURR	01	ESEA:TEACHER Q	1,710.00
PO23-00147	BREAKTHROUGH COACH	Breakthrough Coach PD	CURR	01	NO REPORTING RI	2,475.00
PO23-00148	EDGEWOOD PRESS INC	Dragon Student Folders (Goal 4, Strategy 1)	DLEL	01	IPI GF	940.61
PO23-00149	SCHOOL DATEBOOKS IN	Student Planners (Goal 4, Strategy 1)	DLEL	01	IPI GF	742.39
PO23-00150	AMAZON CAPITAL SERV	CENTRAL OFFICE SUPPLIES	BUSN	01	NO REPORTING RI	750.00
PO23-00151	STAPLES ADVANTAGE	FINANCE OPEN ORDER OFFICE SUPPLIES	FIN	01	NO REPORTING RI	100.00
PO23-00152	NEW YORK TIMES	22-23 New York Times Digital Subscription Renewal	CURR	01	LOTTERY:INSTRU	2,288.00
PO23-00153	LAB-AIDS INC	Lab-Aids Licenses for MH	CURR	01	LOTTERY:INSTRU	450.00
PO23-00154	ACTION AUTO GLASS	22/23 OPEN PO FOR GLASS REPAIR	M&O	01	ONGOING & MAJO	1,500.00
PO23-00155	FOLLETT SCHOOL SOLU	Supplemental Textbooks	HHS	01	BAS GNT LOW-INC	3,194.74
PO23-00156	TEXTBOOK WAREHOUSE	Supplemental Textbooks	HHS	01	BAS GNT LOW-INC	2,051.72
PO23-00157	PALACE BUSINESS SOL	Open PO for Supplies	BVEL	01	NO REPORTING RI	2,400.00
PO23-00158	AMAZON CAPITAL SERV	Open PO for Supplies	BVEL	01	NO REPORTING RI	2,400.00

The preceding Purchase Orders have been issued in accordance with the District's Purchasing Policy and authorization of the Board of Trustees. It is recommended that the preceding Purchase Orders be approved and that payment be authorized upon delivery and acceptance of the items ordered.

ESCAPE ONLINE

Page 6 of 19

Description

Includes Purchase Orders dated 06/04/2022 - 07/31/2022

PO Number	Vendor Name	Requisition Information	Ord Loc	Req Fund	Resource Description	Req Fund Order Amt
PO23-00159	STAPLES ADVANTAGE	Open PO - Copy Paper	BVEL	01	NO REPORTING RI	2,500.00
PO23-00160	OFFICE DEPOT	Open PO for Instructional Supplies	BVEL	01	NO REPORTING RI	2,400.00
PO23-00161	OFFICE DEPOT	INVENTORY ORDER/STORAGE BOXES	WRSH	01	NO REPORTING RI	248.43
PO23-00162	COAST PAPER & SUPPL	INVENTORY/CUSTODIAL ITEMS	WRSH	01	NO REPORTING RI	245.81
PO23-00163	ORGANIZED BINDERS	CSA - Organized Binder	HHS	01	BAS GNT LOW-INC	5,500.00
PO23-00164	CURRICULUM ASSOCIAT	22-23 i-Ready Elementary License Renewal	CURR	01	NO REPORTING RI	79,962.00
PO23-00165	ZEARN INC	22-23 Zearn License Renewal for Elementary Schools	CURR	01	ESSER III ARP	12,500.00
PO23-00166	ACHIEVE 3000 INC	22-23 Achieve3000 Renewal for SCHS, B40 and MH MS	CURR	01	ESEA:ENGLISH LE	9,925.00
PO23-00167	AVID CENTER	22-23 AVID License Renewal	CURR	01	BAS GNT LOW-INC	24,045.00
PO23-00168	IMAGINE LEARNING	22-23 Edgenuity License Renewal	CURR	01	ESSER III ARP	22,080.00
PO23-00169	YOUR FUTURE IS OUR	22-23 YFIOB Services Renewal	CURR	01	CAREER TECHNIC	25,000.00
PO23-00170	LEXIA LEARNING SYST	22-23 Lexia Core5 Reading and English Sub Renewal	CURR	01	ESSER III ARP	82,329.12
PO23-00171	COMMITTEE FOR CHILD	22-23 Second Step License Renewal	CURR	01	NO REPORTING RI	31,838.71
PO23-00172	HOBART SALES & SERV	FS Repair services	FS	13	CHLD NUTR:SCHO	5,000.00
PO23-00173	NEWSELA INC	22-23 Newsela Contract Renewal	CURR	01	LOTTERY:INSTRU	53,500.00
PO23-00174	ACTIVATE LEARNING L	Activate Learning Materials	CURR	01	LOTTERY:INSTRU	7,841.43
PO23-00175	CDW GOVERNMENT INC.	Anywhere 65 Watt USB-C Charger	IT	01	NO REPORTING RI	6,555.00
PO23-00176	C & N TRACTORS	22/23 OPEN PO FOR MOWER REPAIRS	M&O	01	ONGOING & MAJO	9,700.00
PO23-00177	COALITION FOR ADEQU	22/23 ANNUAL MEMBERSHIP RENEWAL NOTICE	M&O	01	ONGOING & MAJO	650.00
PO23-00178	EMS LINQ INC	FS Software Support/Annual Subscription	FS	13	CHLD NUTR:SCHO	2,500.00
PO23-00179	SEQUENTIAL ENVIRONM	FS Annual Maint.	FS	13	CHLD NUTR:SCHO	1,500.00
PO23-00180	SANTA CRUZ FIRE EQU	FS Annual Maint	FS	13	CHLD NUTR:SCHO	1,200.00
PO23-00181	SUPER STEAM	FS Annual Maint.	FS	13	CHLD NUTR:SCHO	2,600.00
PO23-00182	IMAGE ONE CORP	FS Processing Fees	FS	13	CHLD NUTR:SCHO	3,000.00
PO23-00183	ULINE	22/23 OPEN PO FOR SUPPLIES	M&O	01	ONGOING & MAJO	3,700.00
PO23-00184	INDEPENDENT ELECTRI	22/23 OPEN PO FOR ELECTRICAL SUPPLIES	M&O	01	ONGOING & MAJO	3,000.00
PO23-00185	AMAZON.COM	22/23 OPEN PO FOR WAREHOUSE SUPPLIES	M&O	01	ONGOING & MAJO	5,000.00
PO23-00186	FRONTLINE EDUCATION	Frontline Central Annual payment	HR	01	NO REPORTING RI	13,692.14
PO23-00187	SANTA CRUZ COE	ESTIMATED COST/MAGNET CLASSES	DO	01	Measure T	38,000.00
PO23-00188	WATSONVILLE COAST P	Food Purchases	FS	13	CHLD NUTR:SCHO	50,000.00
PO23-00189	GOLD STAR FOODS	Food Purchases	FS	13	CHLD NUTR:SCHO	250,000.00
PO23-00190	DANIELSEN CO.	Food Purchases	FS	13	CHLD NUTR:SCHO	165,000.00
PO23-00191	DANIELSEN CO.	FS Paper Supplies	FS	13	CHLD NUTR:SCHO	17,000.00
PO23-00192	HEARTLAND PAYMENT S	License Renewal Fees	FS	13	CHLD NUTR:SCHO	8,000.00

The preceding Purchase Orders have been issued in accordance with the District's Purchasing Policy and authorization of the Board of Trustees. It is recommended that the preceding Purchase Orders be approved and that payment be authorized upon delivery and acceptance of the items ordered.

ESCAPE ONLINE

Description

Includes Purchase Orders dated 06/04/2022 - 07/31/2022

PO Number	Vendor Name	Requisition Information	Ordr Loc	Req Fund	Resource Description	Req Fund Order Amt
PO23-00193	OLIVER PACKAGING &	FS Paper supplies	FS	13	CHLD NUTR:SCHO	15,000.00
PO23-00194	PRODUCERS DAIRY FOO	Food Purchases	FS	13	CHLD NUTR:SCHO	130,000.00
PO23-00195	SYSCO FOOD SERVICES	Food Purchases	FS	13	CHLD NUTR:SCHO	50,000.00
PO23-00196	SYSCO FOOD SERVICES	FS Paper Supplies	FS	13	CHLD NUTR:SCHO	20,000.00
PO23-00197	P & R PAPER SUPPLY	FS Paper supplies	FS	13	CHLD NUTR:SCHO	40,000.00
PO23-00198	ROGER'S REFRIGERATI	FS Repairs and Maint.	FS	13	CHLD NUTR:SCHO	10,000.00
PO23-00199	DOMINO'S PIZZA	FS Food purchases	FS	13	CHLD NUTR:SCHO	20,000.00
PO23-00200	B & B SMALL ENGINE	22/23 OPEN PO FOR GROUNDS SUPPLIES	M&O	01	ONGOING & MAJO	7,000.00
PO23-00201	CENTRAL COAST SYSTE	22/23 OPEN PO BELL/CLOCK/TELEPHONE/FA SERVICES	M&O	01	ONGOING & MAJO	23,000.00
PO23-00202	KELLY MOORE PAINT C	22/23 OPEN PO FOR PAINT AND SUPPLIES	M&O	01	ONGOING & MAJO	20,000.00
PO23-00203	PALACE BUSINESS SOL	Office Supplies - Open PO for Palace	STUS	01	NO REPORTING RI	1,000.00
PO23-00204	HANDLE WITH CARE BE	Handle With Care - Rishi Lal Registration	STUS	01	NO REPORTING RI	1,375.00
PO23-00205	INLAND LIGHTING SUP	INVENTORY/CUSTODIAL	WRSH	01	NO REPORTING RI	3,100.52
PO23-00206	BAY CENTRAL PRINTIN	INVENTORY/ENVELOPES	WRSH	01	NO REPORTING RI	2,049.32
PO23-00207	AMAZON CAPITAL SERV	Elementary Homeless Supplies	STUS	01	BAS GNT LOW-INC	2,000.00
PO23-00208	SANTA CRUZ METRO	BUS PASSES - DISTRICT ALLOCATION	STUS	01	NO REPORTING RI	6,000.00
PO23-00209	SANTA CRUZ COE BUSI	22-23 LCAP FOSTER ED DIRECT CONTRIBUTION	FIN	01	LCFF SUPP FUNDI	10,000.00
PO23-00210	SAN JOAQUIN COE	Beyond SST Year One	STUS	01	NO REPORTING RI	9,334.00
PO23-00211	HART FLOOR CO.	22/23 ALL HIGH SCHOOL SITES GYM FLOOR MAINTENANCE	M&O	01	ONGOING & MAJO	16,880.00
PO23-00212	CATAPULTK12	Catapult EMS WeTip	STUS	01	NO REPORTING RI	10,843.30
PO23-00213	EWING IRRIGATION PR	22/23 OPEN PO FOR IRRIGATION SUPPLIES	M&O	01	ONGOING & MAJO	17,000.00
PO23-00214	INDEPENDENT RENTAL	22/23 OPEN PO FOR VEHICLE REPAIRS & TRUCK RENTALS	M&O	01	ONGOING & MAJO	10,000.00
PO23-00215	LISA C FRASER	CSA - ADMIN COACHING FOR KATHARINE NORTON	HR	01	ESEA:TEACHER Q	3,000.00
PO23-00216	A TOOL SHED EQUIPME	22/23 OPEN PO FOR EQUIPMENT RENTALS	M&O	01	ONGOING & MAJO	2,400.00
PO23-00217	CRYSTAL SPRINGS WAT	22/23 OPEN PO FOR DRINKING WATER	M&O	01	ONGOING & MAJO	600.00
PO23-00218	TRAVIS PRIOR DBA PR	22/23 OPEN PO FOR TIRE REPAIRS	M&O	01	ONGOING & MAJO	600.00
PO23-00219	PALACE BUSINESS SOL	CENTRAL OFFICE SUPPLIES OPEN ORDER	DO	01	NO REPORTING RI	200.00
PO23-00220	BOARDWALK BOWL	ELEM Summer Camp Bowling Field Trip	CURR	01	BAS GNT LOW-INC	702.00
PO23-00221	AMAZON CAPITAL SERV	Books for Leadership	SUPT	01	NO REPORTING RI	1,320.00
PO23-00222	E3 HCI AUDIOMETRICS	EAR TIPS FOR HEARING SCREENINGS	SPED	01	SE:STATE LOCAL	107.77

The preceding Purchase Orders have been issued in accordance with the District's Purchasing Policy and authorization of the Board of Trustees. It is recommended that the preceding Purchase Orders be approved and that payment be authorized upon delivery and acceptance of the items ordered.

ESCAPE ONLINE

Description

Includes Purchase Orders dated 06/04/2022 - 07/31/2022

PO Number	Vendor Name	Requisition Information	Ordr Loc	Req Fund	Resource Description	Req Fund Order Amt
PO23-00223	HANDLE WITH CARE BE	CFP HANDLE WITH CARE TRAINING	SPED	01	SE:STATE LOCAL	1,375.00
PO23-00224	PAR INC	PSYCHOLOGIST ASSESSMENTS 22-23	SPED	01	SE:STATE LOCAL	119.60
PO23-00225	ACADEMIC THERAPY PU	ATP ASSESSMENTS	SPED	01	SE:STATE LOCAL	59.63
PO23-00226	PRO-ED INC	PSYCHOLOGIST ASSESSMENTS 22-23	SPED	01	SE:STATE LOCAL	126.41
PO23-00227	RIVERSIDE INSIGHTS	PSYCHOLOGIST ASSESSMENTS 22-23	SPED	01	SE:STATE LOCAL	146.68
PO23-00228	SCHOOLHOUSE EDUCATI	PSYCHOLOGY ASSESSMENTS 22-23	SPED	01	SE:STATE LOCAL	559.28
PO23-00229	CANON FINANCIAL SER	22-23 COPIER LEASE PAYMENTS	FIN	01	NO REPORTING RI	100,645.48
PO23-00230	SYCAMORE FARMS	22/23 OPEN PO FOR GOAT USE AS WEED CONTROL	M&O	01	ONGOING & MAJO	44,350.00
PO23-00231	BRIGHT SOLUTIONS FO	DYSLEXIA PROGRAM	SPED	01	Sped Dispute	36,435.08
PO23-00232	PEARSON CLINICAL AS	PSYCHOLOGIST ASSESSMENTS 22-23	SPED	01	SE:STATE LOCAL	5,875.00
PO23-00233	BAY AREA FLOORS & I	DLEL SUPPLY & INSTALL FLOORING	M&O	01	ONGOING & MAJO	7,235.00
PO23-00234	A SIGN ASAP	22/23 OPEN PO FOR SIGNAGE	M&O	01	ONGOING & MAJO	6,000.00
PO23-00235	DANIEL JOHN SIDDENS	Annual PO for Medical Contribution	FIN	01		5,016.00
PO23-00236	AMERICAN MODULAR SY	*GE 2-STORY MOD CLASSROOM BLDG	M&O	21	Bond A Elem	5,249,963.00
PO23-00237	AMERICAN MODULAR SY	*SCH NEW POOL HOUSE	M&O	21	Bond A Secondar	2,147,020.00
PO23-00238	ALBION ENVIRONMENTA	SCH MOD OVERSIGHT	M&O	21	Bond A Secondar	101,488.05
PO23-00239	BEST CONTRACTING SE	*HH GYM REROOF	M&O	21	Bond A Secondar	311,533.00
PO23-00240	ABACHERLI FENCE CO	MHMS MOTORIZED GATE	M&O	21	Bond A Secondar	6,957.50
PO23-00241	ABACHERLI FENCE CO	SCH AUTOMATIC GATE REPLACEMENT	M&O	21	Bond A Secondar	20,665.00
PO23-00242	PEARSON CLINICAL AS	PSYCHOLOGIST ASSESSMENTS 22-23	SPED	01	SE:STATE LOCAL	2,590.00
PO23-00243	WPS	WPS ASSESSMENTS	SPED	01	SE:STATE LOCAL	2,336.11
PO23-00244	LEWIS TREE SERVICE	DLEL TREE & STUMP REMOVAL	M&O	01	ONGOING & MAJO	4,625.00
PO23-00245	ADVANCED BLIND & SH	22/23 OPEN PO FOR BLIND REPAIRS	M&O	01	ONGOING & MAJO	500.00
PO23-00246	FLYERS ENERGY LLC	22/23 OPEN PO FOR FUEL FOR M&O VEHICLES	M&O	01	ONGOING & MAJO	45,000.00
PO23-00247	SAN LORENZO LUMBER	22/23 OPEN PO TOOL/MATERIAL FOR M&O DEPT	M&O	01	ONGOING & MAJO	30,000.00
PO23-00248	COAST LOCK & SAFE	22/23 OPEN PO FOR LOCKS & SUPPLIES	M&O	01	ONGOING & MAJO	5,000.00
PO23-00249	ABA BUILDING SERVIC	22/23 PO FOR FOR EMERGENCY CLEANING SERVICES	M&O	01	ONGOING & MAJO	3,975.00
PO23-00250	CODEHS INC	22-23 CodeHS Licenses for Harbor and Santa Cruz HS	CURR	01	CAREER TECHNIC	5,200.00
PO23-00251	C & N TRACTORS	4WD FRONT MOWER W/ FOLDABLE ROPS FOR M&O	M&O	01	ONGOING & MAJO	33,785.92
PO23-00252	HOME DEPOT INC	22/23 OPEN PO FOR MATERIALS/SUPPLIES	M&O	01	ONGOING & MAJO	48,600.00

The preceding Purchase Orders have been issued in accordance with the District's Purchasing Policy and authorization of the Board of Trustees. It is recommended that the preceding Purchase Orders be approved and that payment be authorized upon delivery and acceptance of the items ordered.

ESCAPE ONLINE

Description

Includes Purchase Orders dated 06/04/2022 - 07/31/2022

PO Number	Vendor Name	Requisition Information	Ordr Loc	Req Fund	Resource Description	Req Fund Order Amt
PO23-00253	SAVVAS LEARNING COM	SAVVAS Licenses for Ark	CURR	01	LOTTERY:INSTRUC	40,719.66
PO23-00254	ACE PORTABLE SERVIC	22/23 OPEN PO FOR PORTA POTTY RENTALS	M&O	01	ONGOING & MAJO	8,000.00
PO23-00255	ACCO-WILSON INC DBA	22/23 OPEN PO FOR REPAIRS PLUMBING & HVAC	M&O	01	ONGOING & MAJO	70,000.00
PO23-00256	ACCO-WILSON INC DBA	SQHS REPLACE HOT WATER ACTUATORS&THERMOSTATS	M&O	01	ONGOING & MAJO	9,550.00
PO23-00257	COMPLETE MAILING SE	OPEN PO TO PRINT MATH ACADEMY BOOKS	SCHS	01	NO REPORTING RI	5,000.00
PO23-00258	SAN JOAQUIN COE	EDJoin Annual Fee 22-23	HR	01	NO REPORTING RI	1,605.50
PO23-00259	CREATIVE WINDOW IN	DLV WINDOW SHADES	M&O	21	Bond A Elem	4,140.00
PO23-00260	OFFICE DEPOT	Open PO for color paper	DLEL	01	NO REPORTING RI	400.00
PO23-00261	AMAZON CAPITAL SERV	Open PO Amazon- Insturctional Supplies	DLEL	01	NO REPORTING RI	6,358.65
PO23-00262	PALACE BUSINESS SOL	Open PO Palace- Insturctional Supplies	DLEL	01	NO REPORTING RI	600.00
PO23-00263	ALBION ENVIRONMENTA	SCH SWITCHGEAR	M&O	21	Bond A Secondar	913.94
PO23-00264	REALLY GOOD STUFF I	D. Ezroj-instructional materials	DLEL	01	NO REPORTING RI	77.44
PO23-00265	RIVERSIDE LIGHTING	22/23 OPEN PO FOR ELECTRICAL PARTS/SUPPLIES	M&O	01	ONGOING & MAJO	3,000.00
PO23-00266	AA SAFE & LOCK COMP	22/23 OPEN PO FOR LOCKS AND SUPPLIES	M&O	01	ONGOING & MAJO	800.00
PO23-00267	THE PRINT GALLERY	PRINTING SERVICES	SQHS	01	NO REPORTING RI	2,000.00
PO23-00268	UC REGENTS UCSC	Ethnic Studies PD	CURR	01	ESSER III ARP	750.00
PO23-00269	EDGEWOOD PRESS INC	Wildcat Folders	WLEL	01	NO REPORTING RI	1,009.86
PO23-00270	PALACE BUSINESS SOL	OPEN ORDER OFFICE SUPPLIES	WLEL	01	NO REPORTING RI	500.00
PO23-00271	PALACE BUSINESS SOL	OPEN ORDER FOR INSTR. SUPPLIES	WLEL	01	NO REPORTING RI	700.00
PO23-00272	STAPLES ADVANTAGE	OPEN ORDER FOR COPY PAPER	WLEL	01	NO REPORTING RI	2,000.00
PO23-00273	AMAZON CAPITAL SERV	Open Purchase order for instr. supplies	WLEL	01	NO REPORTING RI	500.00
PO23-00274	HEGGERTY PHONEMIC A	Curriculum Materials for RTI	WLEL	01	NO REPORTING RI	1,466.80
PO23-00275	SURTEC INC	INVENTORY - CUSTODIAL	WRSH	01	NO REPORTING RI	1,807.54
PO23-00276	EDPUZZLE INC	22-23 EdPuzzle Renewal (Secondary)	CURR	01	ESSER II	8,100.00
PO23-00277	AMPLIFIED IT LLC	22-23 Amplified IT Contract Renewal	CURR	01	ESSER II	8,016.00
PO23-00278	SCREENCASTIFY LLC	22-23 Screencastify Contract Renewal (Secondary)	CURR	01	ESSER II	9,690.00
PO23-00279	PEAR DECK INC	22-23 Pear Deck License Agreement (Secondary)	CURR	01	ESSER II	13,120.00
PO23-00280	LEARNING ALLY INC	22-23 Learning Ally License Renewal (SEC)	CURR	01	ESSER II	12,794.00
PO23-00281	HILTON SAN FRANCISC	AVID Summer Institute Hotel	CURR	01	ESSER III ARP	13,950.00
PO23-00282	WESTED	22-23 WestEd Contract for Middle Schools	CURR	01	ESSER II	68,500.00
PO23-00283	CDW GOVERNMENT INC.	MHMS TOUCH PANELS	M&O	21	Bond A Secondar	100,900.00
PO23-00284	CDW GOVERNMENT INC.	B40MS TOUCH PANELS	M&O	21	Bond A Secondar	117,500.00

The preceding Purchase Orders have been issued in accordance with the District's Purchasing Policy and authorization of the Board of Trustees. It is recommended that the preceding Purchase Orders be approved and that payment be authorized upon delivery and acceptance of the items ordered.

ESCAPE ONLINE

Description

Includes Purchase Orders dated 06/04/2022 - 07/31/2022

PO Number	Vendor Name	Requisition Information	Ordr Loc	Req Fund	Resource Description	Req Fund Order Amt
PO23-00285	ALBION ENVIRONMENTA	MHMS SWITCHGEAR ARCHEOLOGICAL MONITORING	M&O	21	Bond A Secondar	17,482.54
PO23-00286	ALBION ENVIRONMENTA	SCH UNDERGROUND UTILITY MONITORING	M&O	21	Bond A Secondar	39,702.20
PO23-00287	SANTA CRUZ RECORDS	22/23 OPEN PO FOR SHREDDING SERVICES	M&O	01	ONGOING & MAJO	5,500.00
PO23-00288	HINES PEST & WEED C	22/23 OPEN PO FOR PEST CONTROL AT ALL SITES	M&O	01	ONGOING & MAJO	5,000.00
PO23-00289	ABACHERLI FENCE CO	22/23 OPEN PO FOR FENCE REPAIRS AT VARIOUS SITES	M&O	01	ONGOING & MAJO	7,500.00
PO23-00290	FERGUSON ENTERPRISE	22/23 OPEN PO FOR PARTS/SUPPLIES	M&O	01	ONGOING & MAJO	15,000.00
PO23-00291	SANTA CRUZ SENTINEL	BOND ADVERTISING	M&O	21	Bond A Secondar	20,000.00
PO23-00292	SC SYSTEMS	BV PORTABLE DEMO & IDF	M&O	21	Bond A Elem	7,200.00
PO23-00293	SC SYSTEMS	DLV PORTABLE DEMO	M&O	21	Bond A Elem	2,800.00
PO23-00294	PALACE BUSINESS SOL	22/23 OPEN PO FOR OFFICE SUPPLIES M&O DEPT	M&O	01	ONGOING & MAJO	1,000.00
PO23-00295	AUTO CARE LIFESAVER	22/23 OPEN PO FOR TOWING SERVICES	M&O	01	ONGOING & MAJO	500.00
PO23-00296	ROTARY CLUB OF SANT	Rotarty Membership 22-23	SUPT	01	NO REPORTING RI	2,600.00
PO23-00297	PALACE BUSINESS SOL	Supplies for 22-23	SUPT	01	NO REPORTING RI	150.00
PO23-00298	AMAZON CAPITAL SERV	Supplies for 22-23	SUPT	01	NO REPORTING RI	1,000.00
PO23-00299	ACSA	22-23 ACSA Membership	SUPT	01	NO REPORTING RI	1,780.00
PO23-00300	AMERICAN RED CROSS	Red cross CPR training materials	HR	01	Measure T	1,358.49
PO23-00301	COAST PAPER & SUPPL	OPEN ORDER Custodial Supplies	WLEL	01	NO REPORTING RI	3,000.00
PO23-00302	SOQUEL CREEK WATER	WATER SERVICE ACCT 10-16753-00	FIN	01	NO REPORTING RI	1,100.00
PO23-00303	SANTA CRUZ MUNICIPA	WATER - ADULT ED	FIN	11	ADULT ED APPOR'	752.00
PO23-00304	SANTA CRUZ MUNICIPA	REFUSE ADULT ED	FIN	11	ADULT ED APPOR'	3,200.00
PO23-00305	SANTA CRUZ MUNICIPA	SEWER ADULT ED	FIN	11	ADULT ED APPOR'	500.00
PO23-00306	COAST PAPER & SUPPL	Open PO Custodial Supplies	DLEL	01	NO REPORTING RI	2,400.00
PO23-00307	COAST PAPER & SUPPL	CUSTODIAL SUPPLIES	DO	01	NO REPORTING RI	4,500.00
PO23-00308	GENERAL BINDING COR	Laminating film G1,A3	BSS	01	NO REPORTING RI	240.35
PO23-00309	SPURR	SPURR UTILITIES GEN FUND	FIN	01	NO REPORTING RI	517,000.00
PO23-00310	SOQUEL CREEK WATER	WATER SERVICE ACCT 42-16754-00	FIN	01	NO REPORTING RI	51,000.00
PO23-00311	SOQUEL CREEK WATER	WATER SERVICE ACCT 42-16756-00	FIN	01	NO REPORTING RI	48,000.00
PO23-00312	SANTA CRUZ MUNICIPA	WATER GEN FUND	DO	01	NO REPORTING RI	276,000.00
PO23-00313	SANTA CRUZ MUNICIPA	REFUSE GEN FUND	DO	01	NO REPORTING RI	150,800.00
PO23-00314	SANTA CRUZ MUNICIPA	SEWER GEN FUND	DO	01	NO REPORTING RI	40,000.00
PO23-00315	GOT GOPHERS INC	22/23 OPEN PO FOR GOPHER CONTROL ALL SITES	M&O	01	ONGOING & MAJO	11,000.00
PO23-00316	SANTA CRUZ COUNTY S	COUNTY SEWER CHARGES	FIN	01	NO REPORTING RI	37,282.00
PO23-00317	COAST PAPER & SUPPL	Open PO for Custodial Supplies	HHS	01	NO REPORTING RI	10,000.00
PO23-00318	SIERRA SCHOOL EQUIP	BV STUDENT DESK BOOKBOXES	M&O	21	Bond A Elem	6,395.50

The preceding Purchase Orders have been issued in accordance with the District's Purchasing Policy and authorization of the Board of Trustees. It is recommended that the preceding Purchase Orders be approved and that payment be authorized upon delivery and acceptance of the items ordered.

ESCAPE ONLINE

Includes Purchase Orders dated 06/04/2022 - 07/31/2022

PO Number	Vendor Name	Requisition Information	Ord Loc	Req Fund	Resource Description	Req Fund Order Amt
PO23-00319	SCHOOLS EXCESS LIAB	AB 218 REVIVED LIABILITY FUNDING PLAN	FIN	01	NO REPORTING RI	64,785.44
PO23-00320	CINTAS CORPORATIONS	22/23 OPEN PO FOR CUSTODIAL MOPS & RAGS	M&O	01	NO REPORTING RI	14,000.00
PO23-00321	COAST PAPER & SUPPL	22/23 OPEN PO FOR JANITORAL SUPPLIES	M&O	01	NO REPORTING RI	18,000.00
PO23-00322	KEENAN	CYBER SECURITY INSURANCE POLICY	FIN	01	NO REPORTING RI	36,137.50
PO23-00323	CAROLYN R POST	Carolyn Post CSA 22-23	SUPT	01	NO REPORTING RI	10,000.00
PO23-00324	FAGEN FRIEDMAN & FU	22-23 Legal Services	SUPT	01	NO REPORTING RI	30,000.00
PO23-00325	LOZANO SMITH LLP	22-23 Legal Services	SUPT	01	NO REPORTING RI	70,000.00
PO23-00326	CSBA	CSBA 22-23 Membership	SUPT	01	NO REPORTING RI	16,680.00
PO23-00327	PACIFIC COAST TRANE	22/23 OPEN PO FOR HVAC SERVICE	M&O	01	ONGOING & MAJO	18,000.00
PO23-00328	BOBBYS PIT STOP INC	22/23 OPEN PO FOR VEHICLE REPAIRS	M&O	01	ONGOING & MAJO	1,000.00
PO23-00329	CERTIFIED BACKFLOW	22/23 OPEN PO BACKFLOW TESTING AT ALL SCCS SITES	M&O	01	ONGOING & MAJO	3,000.00
PO23-00330	PITNEY BOWES INC	OPEN ORDER POSTAGE METER SUPPLIES	DO	01	NO REPORTING RI	500.00
PO23-00331	A SIGN ASAP	Invoice #220314	PERC	01	NO REPORTING RI	164.63
PO23-00332	CSPCA DOWNEY UNIFIE	CSPCA Invoice #74-2022-23	PERC	01	NO REPORTING RI	700.00
PO23-00333	CODESP	Codesp Invoice #0005349	PERC	01	NO REPORTING RI	2,300.00
PO23-00334	PITNEY BOWES GLOBAL	POSTAGE METER LEASE	DO	01	NO REPORTING RI	4,527.40
PO23-00335	AMAZON CAPITAL SERV	IT Amazon Open PO	IT	01	NO REPORTING RI	2,000.00
PO23-00336	AMANDA PACKER	AP PARENT REIMBS - (RE: JP/SETTLEMENT AGREEMENT)	SPED	01	SE:STATE LOCAL	3,657.00
PO23-00337	LAB-AIDS INC	Lab-Aids Licenses for B40MS	CURR	01	LOTTERY:INSTRU	450.00
PO23-00338	PALACE BUSINESS SOL	DLV LIBRARIAN KEYBOARD PLATFORM	M&O	21	Bond A Elem	203.21
PO23-00339	DILBECK & SONS INC	*DO ADA AUTOMATIC DOOR OPERATORS	M&O	21	Bond A Secondar	2,097.45
PO23-00340	HOSE SHOP	22/23 OPEN PO FOR PARTS NEEDED FOR M&O	M&O	01	ONGOING & MAJO	500.00
PO23-00341	JOHNSON CONTROLS IN	22/23 OPEN PO FOR HVAC MATERIALS/SUPPLIES	M&O	01	ONGOING & MAJO	2,500.00
PO23-00342	ACE PORTABLE SERVIC	TRANSPORTATION BLDG PORTAPOTTY	M&O	21	Bond A Secondar	2,477.84
PO23-00343	WESTSIDE HARDWARE	22/23 OPEN PO FOR PARTS AND SUPPLIES FOR M&O	M&O	01	ONGOING & MAJO	2,000.00
PO23-00344	OFFICE DEPOT	22/23 OPEN PO FOR OFFICE SUPPLIES	M&O	01	ONGOING & MAJO	1,000.00
PO23-00345	PAPE MATERIAL HANDL	22/23 OPEN PO FOR FORK LIFT REPAIRS	M&O	01	ONGOING & MAJO	2,500.00
PO23-00346	CLEAN TEAM ASSOCIAT	22/23 OPEN PO CLEAN HOMELESS CAMPS	M&O	01	ONGOING & MAJO	1,000.00

The preceding Purchase Orders have been issued in accordance with the District's Purchasing Policy and authorization of the Board of Trustees. It is recommended that the preceding Purchase Orders be approved and that payment be authorized upon delivery and acceptance of the items ordered.

ESCAPE ONLINE

Description

Includes Purchase Orders dated 06/04/2022 - 07/31/2022

PO Number	Vendor Name	Requisition Information	Ordr Loc	Req Fund	Resource Description	Req Fund Order Amt
PO23-00347	PHIL ALLEGRI ELECTR	22/23 OPEN PO FOR ELECTRICAL REPAIRS	M&O	01	ONGOING & MAJO	1,000.00
PO23-00348	ROGER'S REFRIGERATI	22/23 OPEN PO FOR REFRIGERATION REPAIRS	M&O	01	ONGOING & MAJO	500.00
PO23-00349	ROYAL WHOLESALE ELE	22/23 OPEN PO ELECTRICAL PARTS/SUPPLIES	M&O	01	ONGOING & MAJO	1,000.00
PO23-00350	SANTA CRUZ AUTO PAR	22/23 OPEN PO FOR AUTO PARTS & SUPPLIES	M&O	01	ONGOING & MAJO	2,000.00
PO23-00351	SANTA CRUZ ELECTRON	22/23 OPEN PO FOR SUPPLIES	M&O	01	ONGOING & MAJO	500.00
PO23-00352	SHIFFLER EQUIPMENT	22/23 OPEN PO BATHRM PARTITION PARTS & SUPPLIES	M&O	01	ONGOING & MAJO	1,500.00
PO23-00353	SOQUEL NURSERY GROV	22/23 OPEN PO PLANTS NEEDED AT VARIOUS SITES	M&O	01	ONGOING & MAJO	1,000.00
PO23-00354	SPRAY MART II	22/23 OPEN PO FOR PAINT EQUIPMENT REPAIRS	M&O	01	NO REPORTING RI	500.00
PO23-00355	STAPLES ADVANTAGE	22/23 OPEN PO FOR OFFICE SUPPLIES M&O DEPT	M&O	01	ONGOING & MAJO	500.00
PO23-00356	SURTEC INC	22/23 OPEN PO-REPAIRS/SERVICES	M&O	01	ONGOING & MAJO	11,500.00
PO23-00357	TOYOTA MATERIAL HAN	22/23 OPEN PO FOR GOLF CART REPAIRS	M&O	01	ONGOING & MAJO	2,000.00
PO23-00358	TRI DIM FILTER	22/23 OPEN PO FOR FILTERS	M&O	01	ONGOING & MAJO	1,000.00
PO23-00359	TURF & INDUSTRIAL E	22/23 OPEN PO FOR GROUNDS PARTS/SUPPLIES	M&O	01	ONGOING & MAJO	3,000.00
PO23-00360	UNITED RENTALS	22/23 OPEN PO FOR EQUIPMENT RENTALS	M&O	01	ONGOING & MAJO	2,500.00
PO23-00361	INTRADO INTERACTIVE	Intrado Website Hosting Service	SUPT	01	NO REPORTING RI	2,030.00
PO23-00362	SUPERIOR ALARM CO	22/23 OPEN PO FOR ALARM MONITORING	M&O	01	NO REPORTING RI	4,000.00
PO23-00363	ATLANTIS PAVING & G	*BV SITE WORK	M&O	21	Bond A Elem	96,694.95
PO23-00364	THE DAVEY TREE EXPE	22/23 OPEN PO TREE TRIMMING SERVICES	M&O	01	ONGOING & MAJO	10,000.00
PO23-00365	CRW INDUSTRIES INC	*SCH C & D MODERNIZATION	M&O	21	Bond A Secondar	6,669,907.65
PO23-00366	CRW INDUSTRIES INC	*SCH SWITCHGEAR REPLACEMENT	M&O	21	Bond A Secondar	79,819.98
PO23-00367	CYCLONE FENCE & IRO	*WL FENCE REPLACEMENT	M&O	21	Bond A Elem	14,802.00
PO23-00368	PITNEY BOWES BANK I	PURCHASE POWER ACCT. (POSTAGE)	DO	01	NO REPORTING RI	5,000.00
PO23-00369	EAST BAY RESTAURANT	HH KITCHEN OVEN	M&O	21	Bond A Secondar	39,288.92
PO23-00370	HB RESTORATION INC	*WL EXTERIOR PAINT	M&O	21	Bond A Elem	5,132.50
PO23-00371	ROSS RECREATION EQU	BV BALL WALL	M&O	21	Bond A Elem	18,427.48
PO23-00373	LANDSCAPE STRUCTURE	*DLV PLAY EQUIP RETROFIT	M&O	21	Bond A Elem	98,427.12
PO23-00374	ROSS RECREATION EQU	*DLV KINDER PLAYGROUND SITE WORK	M&O	21	Bond A Elem	190,153.45
PO23-00375	ROSS RECREATION EQU	*DLV KINDER PLAYGROUND PIP	M&O	21	Bond A Elem	104,246.84
PO23-00376	ACCO-WILSON INC DBA	BMS FURNISH & INSTALL (4) ACTUATORS	M&O	01	ONGOING & MAJO	2,368.00

The preceding Purchase Orders have been issued in accordance with the District's Purchasing Policy and authorization of the Board of Trustees. It is recommended that the preceding Purchase Orders be approved and that payment be authorized upon delivery and acceptance of the items ordered.

ESCAPE ONLINE

Page 13 of 19

Description

Includes Purchase Orders dated 06/04/2022 - 07/31/2022

PO Number	Vendor Name	Requisition Information	Ord Loc	Req Fund	Resource Description	Req Fund Order Amt
PO23-00377	ACCO-WILSON INC DBA	DLEL (4) INSTALL PILLOW BLOCK BEARING & BELTS	M&O	01	ONGOING & MAJO	4,745.44
PO23-00378	DILBECK & SONS INC	SCH EXTERIOR DOORS	M&O	21	Bond A Secondar	36,960.00
PO23-00379	19SIX ARCHITECTS	B40SS MOD PH 1	M&O	21	Bond A Elem	56,342.13
PO23-00380	19SIX ARCHITECTS	B40SS MOD PH 2	M&O	21	Bond A Elem	84,725.00
PO23-00381	HOUGHTON MIFFLIN CO	22-23 Read 180 Subscription Renewal	CURR	01	ESSER III ARP	31,987.39
PO23-00382	CURRICULUM ASSOCIAT	22-23 i-Ready Secondary License Renewal	CURR	01	ESSER III ARP	48,300.00
PO23-00383	19SIX ARCHITECTS	B40SS PORTABLE DEMO	M&O	21	Bond A Elem	46,800.00
PO23-00384	19SIX ARCHITECTS	BV PORTABLE DEMO	M&O	21	Bond A Elem	60,585.40
PO23-00385	19SIX ARCHITECTS	DLV PARKING LOT	M&O	21	Bond A Elem	13,773.39
PO23-00386	19SIX ARCHITECTS	DLV PORTABLE DEMO	M&O	21	Bond A Elem	72,954.53
PO23-00387	M3 ENVIRONMENTAL CO	22/23 OPEN PO HAZARDOUS MATERIAL/AIR TESTING	M&O	01	ONGOING & MAJO	5,000.00
PO23-00388	19SIX ARCHITECTS	SQ FITNESS	M&O	21	Bond A Secondar	46,999.00
PO23-00389	19SIX ARCHITECTS	SQ CULINARY ARTS MOD	M&O	21	Bond A Secondar	82,951.00
PO23-00390	19SIX ARCHITECTS	SQ MOD PHASE 3	M&O	21	Bond A Secondar	33,300.02
PO23-00391	19SIX ARCHITECTS	SQ PERFORMING ARTS DESIGN	M&O	21	Bond A Secondar	93,521.87
PO23-00392	SUPERIOR ALARM CO	22/23 OPEN PO FOR ALARM REPAIRS	M&O	01	ONGOING & MAJO	10,000.00
PO23-00393	PSR ELECTRIC	22/23 OPEN PO FOR ELECTRICAL REPAIRS	M&O	01	ONGOING & MAJO	5,000.00
PO23-00394	BELLI ARCHITECTURAL	DLV CENTRAL KITCHEN REFRIGERATION	M&O	21	Bond A Secondar	16,100.00
PO23-00395	BELLI ARCHITECTURAL	HH CENTRAL KITCHEN FREEZER	M&O	21	Bond A Secondar	59,582.30
PO23-00396	MONTEREY PENINSULA	*MAINTENANCE YARD PAVING	M&O	21	Bond A Secondar	96,120.00
PO23-00397	AMERICAN MODULAR SY	*TRANSPORTATION BLDG	M&O	21	Bond A Secondar	160,794.55
PO23-00398	KENT CONSTRUCTION	*TRANSPORTATION BLDG SITE WORK	M&O	21	Bond A Secondar	270,127.19
PO23-00399	PREMIER INSPECTION	TRANSPORTATION IOR	M&O	21	Bond A Secondar	7,590.00
PO23-00400	MEDICAL BILLING TEC	22/23-MBT: YR 3 of 5 PRIVATE CORPORATION CONTRACT	SPED	01	OTHER RESTRICT	25,000.00
PO23-00401	SANTA CRUZ FIRE EQU	22/23 OPEN PO FOR FIRE EXT. REPAIRS & INSPECTIONS	M&O	01	ONGOING & MAJO	12,000.00
PO23-00402	BELLI ARCHITECTURAL	B40MS CLASSROOM MOD PH 2	M&O	21	Bond A Secondar	93,900.99
PO23-00403	PITNEY BOWES BANK I	PITNEY BOWES RESERVE ACCT./POSTAGE	DO	01	NO REPORTING RI	23,000.00
PO23-00405	ART GRAMS INSPECTIO	SQ FITNESS INSPECTION	M&O	21	Bond A Secondar	12,500.00
PO23-00406	BRANNON CORPORATION	!STOP!*B40SS AFE SITE WORK	M&O	21	Bond A Elem	87,300.40
PO23-00407	CREATIVE WINDOW IN	22/23 OPEN PO FOR CODE RED MANUAL ROLLER SHADES	M&O	01	ONGOING & MAJO	500.00
PO23-00408	M3 ENVIRONMENTAL CO	HH KILN ROOM ABATEMENT OVERSIGHT	M&O	21	Bond A Secondar	4,445.00
PO23-00409	MOORE TWINING ASSOC	MHMS SWITCHGEAR TESTING	M&O	21	Bond A Secondar	523.75
PO23-00410	MOORE TWINING ASSOC	SCH SWITCHGEAR TESTING	M&O	21	Bond A Secondar	4,418.25
PO23-00411	MOORE TWINING ASSOC	WL SWITCHGEAR TESTING	M&O	21	Bond A Elem	4,745.50

The preceding Purchase Orders have been issued in accordance with the District's Purchasing Policy and authorization of the Board of Trustees. It is recommended that the preceding Purchase Orders be approved and that payment be authorized upon delivery and acceptance of the items ordered.

ESCAPE ONLINE

Description

Includes Purchase Orders dated 06/04/2022 - 07/31/2022

PO Number	Vendor Name	Requisition Information	Ordr Loc	Req Fund	Resource Description	Req Fund Order Amt
PO23-00412	LOCATELLI MOVING &	SCH CLASSROOM RELOCATION	M&O	21	Bond A Secondar	10,157.00
PO23-00413	M3 ENVIRONMENTAL CO	SCH C&D MOD ABATEMENT OVERSIGHT	M&O	21	Bond A Secondar	42,620.00
PO23-00414	LEACH GROUP INC	MHMS SWITCHGEAR INSP	M&O	21	Bond A Secondar	16,920.00
PO23-00415	LEACH GROUP INC	SCH SWITCHGEAR	M&O	21	Bond A Secondar	11,050.00
PO23-00416	LEACH GROUP INC	WL SWITCHGEAR	M&O	21	Bond A Elem	21,060.00
PO23-00417	EMKAY FOREST AND LA	E/L-F PARENT'S REIMBS / YEAR2 (RE: ARF/FSAGRMT)	SPED	01	SE:STATE LOCAL	24,597.66
PO23-00418	CSBA	22-23 CSBA GAMUT Policy Plus Membership	SUPT	01	NO REPORTING RI	6,330.00
PO23-00419	SC COUNTY SHERIFF -	SRO 22-23 SC Sheriff	SUPT	01	NO REPORTING RI	82,000.00
PO23-00420	WALLACE-KUHL & ASSO	SQ FITNESS SPECIAL INSPECTIONS	M&O	21	Bond A Secondar	5,000.00
PO23-00421	CENTRAL HOME SUPPLY	22/23 OPEN PO FOR GROUNDS MATERIAL/SUPPLIES	M&O	01	ONGOING & MAJO	30,000.00
PO23-00422	COMMUNITY TREE SERV	22/23 OPEN PO FOR EMERGENCY TREE SERVICE	M&O	01	ONGOING & MAJO	10,000.00
PO23-00423	CONSOLIDATED PLUMBI	22/23 STORM DRAIN WORK AT VARIOUS SITES	M&O	01	ONGOING & MAJO	15,000.00
PO23-00424	JOHN'S ELECTRIC MOT	22/23 OPEN PO FOR EQUIPMENT REPAIRS	M&O	01	ONGOING & MAJO	5,000.00
PO23-00425	RIVERSIDE COE COLLE	Riverside COE MOU	CURR	01	ESSER III ARP	25,900.00
PO23-00426	NORTH GLASS	22/23 OPEN PO WINDOW REPAIRS	M&O	01	ONGOING & MAJO	6,000.00
PO23-00427	NORTH BAY FORD	22/23 OPEN PO FOR VEHICLE REPAIRS	M&O	01	ONGOING & MAJO	25,000.00
PO23-00428	BELLI ARCHITECTURAL	B40MS GEN CLASSROOM MODS PH1	M&O	21	Bond A Secondar	68,993.50
PO23-00429	DILBECK & SONS INC	*DLV KINDER WINDOW ASSEMBLY	M&O	21	Bond A Elem	6,328.06
PO23-00430	DILBECK & SONS INC	B40SS TV INSTALL	M&O	21	Bond A Elem	29,175.00
PO23-00431	FIBER OPTIC TELECOM	DW STAFF KEY CARD CREATION	M&O	21	Bond A Secondar	13,246.00
PO23-00432	MOORE TWINING ASSOC	FACILITIES YARD TESTING	M&O	21	Bond A Secondar	16,048.00
PO23-00433	MOORE TWINING ASSOC	SCH UNDERGROUND UTILITY REPLACEMENT	M&O	21	Bond A Secondar	11,463.50
PO23-00434	NETXPERS INC	BV & GE DOOR HARDWARE INSTALL	M&O	21	Bond A Elem	67,407.25
PO23-00435	PSR ELECTRIC	HH THEATER DIMMING	M&O	21	Bond A Secondar	59,500.00
PO23-00436	LEXIA LEARNING SYST	Lexia English PD	CURR	01	ESEA:STDNT SUPP	4,250.00
PO23-00437	VERDE DESIGN INC	SCH BASEBALL BACKSTOP MODIFICATION	M&O	21	Bond A Secondar	1,375.00
PO23-00438	COLBI TECHNOLOGIES	SECURE BIDS SOFTWARE ANNUAL	M&O	21	Bond A Secondar	2,500.00
PO23-00439	SAN LORENZO LUMBER	FAC DOOR HARDWARE	M&O	21	Bond A Secondar	13,730.11
PO23-00440	KLEINFELDER INC	SQ FITNESS MOD TESTING	M&O	21	Bond A Secondar	17,915.00
PO23-00441	MOORE TWINING ASSOC	SCH C&D INSPECTIONS	M&O	21	Bond A Secondar	22,703.00
PO23-00442	SANTA CLARA VALLEY	SCH C&D MOD INSPECTIONS	M&O	21	Bond A Secondar	325,600.00
PO23-00443	MEDIA FLEX INC	22-23 OPALS Renewal	CURR	01	Measure T	9,700.00
PO23-00444	RENAISSANCE LEARNIN	Holy Cross School Star Basic	CURR	01	ESEA:TEACHER Q	1,595.00

The preceding Purchase Orders have been issued in accordance with the District's Purchasing Policy and authorization of the Board of Trustees. It is recommended that the preceding Purchase Orders be approved and that payment be authorized upon delivery and acceptance of the items ordered.

ESCAPE ONLINE

Page 15 of 19

Description

Includes Purchase Orders dated 06/04/2022 - 07/31/2022

PO Number	Vendor Name	Requisition Information	Ordr Loc	Req Fund	Resource Description	Req Fund Order Amt
PO23-00445	NETXPERS INC	DLV & WL DOOR HARDWARE INSTALL	M&O	21	Bond A Elem	74,591.00
PO23-00446	CRW INDUSTRIES INC	HH FOOD SERVICE OFFICE REMOVAL	M&O	21	Bond A Secondar	19,000.00
PO23-00447	COLBI TECHNOLOGIES	BOND QUALITY BIDDERS SOFTWARE ANNUAL	M&O	21	Bond A Secondar	50,750.00
PO23-00448	COLBI TECHNOLOGIES	BOND ACCOUNTABILITY SOFTWARE ANNUAL	M&O	21	Bond A Secondar	30,000.00
PO23-00449	UNIVERSITY OF OREGO	PBISApp- SWIS Annual License	STUS	01	NO REPORTING RI	1,400.00
PO23-00450	AMAZON CAPITAL SERV	Amazon Supplies	STUS	01	NO REPORTING RI	300.00
PO23-00451	AMAZON CAPITAL SERV	Secondary Homeless Supplies-Backpacks	STUS	01	BAS GNT LOW-INC	5,000.00
PO23-00452	KONE INC	22/23 MONTHLY ELEVATOR MAINTENANCE	M&O	01	ONGOING & MAJO	21,108.00
PO23-00453	KONE INC	22/23 - OPEN PO FOR ELEVATOR REPAIRS PER SITE	M&O	01	ONGOING & MAJO	10,000.00
PO23-00454	PACIFIC MATERIAL HA	22/23 OPEN PO FOR FORKLIFT MAINTENCE	M&O	01	NO REPORTING RI	1,000.00
PO23-00455	STARK LEAK DETECTIO	22/23 OPEN PO FOR LEAK DETECTION AT ALL SITES	M&O	01	ONGOING & MAJO	500.00
PO23-00456	SHERWIN WILLIAMS CO	22/23 OPEN PO PAINT & SUPPLIES	M&O	01	ONGOING & MAJO	2,500.00
PO23-00457	VALLEY ATHLETICS FI	22/23 OPEN PO ATHLETIC FIELD PAINT AND SUPPLIES	M&O	01	ONGOING & MAJO	1,500.00
PO23-00458	AMAZON CAPITAL SERV	Materials for Elem CIA Director	CURR	01	NO REPORTING RI	166.92
PO23-00459	HART FLOOR CO.	HH FURNISH & INSTALL NEW FLOOR IN GYM	M&O	01	ONGOING & MAJO	11,842.00
PO23-00460	AMAZON CAPITAL SERV	Open-Ark supplies. G1, A6.	BSS	01	LCFF SUPP FUNDI	1,000.00
PO23-00461	AMAZON CAPITAL SERV	Open-AFE supplies. G1,A3.	BSS	01	LCFF SUPP FUNDI	1,000.00
PO23-00462	AMAZON CAPITAL SERV	Books for Leadership	SUPT	01	NO REPORTING RI	309.18
PO23-00463	COMMUNITY PRINTERS	Staff Business Cards	BVEL	01	NO REPORTING RI	800.00
PO23-00464	HART FLOOR CO.	HH REMOVE & REPLACE GYM FLOOR (WATER DAMAGE)	M&O	01	ONGOING & MAJO	5,881.00
PO23-00465	DIRECT LINE TELE RE	22/23 OPEN PO ON CALL EMERGENCY ANSWERING SERVICE	M&O	01	ONGOING & MAJO	2,000.00
PO23-00466	JET MULCH INC	22/23 OPEN PO FOR WOOD FIBER INSTALLATION	M&O	01	ONGOING & MAJO	2,000.00
PO23-00467	RAY MORGAN CO.	XMEDIUS CLOUD FAX SOFTWARE	DO	01	NO REPORTING RI	2,540.00
PO23-00468	RAY MORGAN CO.	LASERFICHE ANNUAL RENEWAL	FIN	01	NO REPORTING RI	2,212.50
PO23-00469	CONSOLIDATED PLUMBI	DLV SEWER REPAIRS	M&O	21	Bond A Elem	14,063.00
PO23-00470	DILBECK & SONS INC	22/23 OPEN PO REPAIRS	M&O	01	ONGOING & MAJO	10,000.00
PO23-00471	CROWE LLP	BOND AUDIT SERVICES	FIN	21	Bond A Secondar	26,000.00
PO23-00472	AT&T	AT&T Dedicated Ethernet Contract	IT	01	NO REPORTING RI	12,840.00
PO23-00473	AT&T	AT&T ASE CIRCUITS	DO	01	NO REPORTING RI	64,000.00
PO23-00474	SC SYSTEMS	22/23 OPEN PO PHONE & FIRE ALARM REPAIRS	M&O	01	ONGOING & MAJO	5,000.00

The preceding Purchase Orders have been issued in accordance with the District's Purchasing Policy and authorization of the Board of Trustees. It is recommended that the preceding Purchase Orders be approved and that payment be authorized upon delivery and acceptance of the items ordered.

ESCAPE ONLINE

Description

Includes Purchase Orders dated 06/04/2022 - 07/31/2022

PO Number	Vendor Name	Requisition Information	Ord Loc	Req Fund	Resource Description	Req Fund Order Amt
PO23-00475	COMCAST	22/23 OPEN PO FOR MONTHLY CHARGES	M&O	01	ONGOING & MAJO	3,400.00
PO23-00476	ROSS RECREATION EQU	22/23 OPEN PO FOR PLAYGROUND EQP. REPAIRS	M&O	01	ONGOING & MAJO	7,500.00
PO23-00477	DEMCO INC	Open PO- Library Supplies	DLEL	01	NO REPORTING RI	500.00
PO23-00478	COMMUNITY PRINTERS	Business Cards for Principal and Office Staff	DLEL	01	NO REPORTING RI	200.00
PO23-00479	AMAZON CAPITAL SERV	Amazon Open PO- TK instructional supplies	DLEL	01	UNIV PRE-K PLAN	5,000.00
PO23-00480	AMERICAN SUPPLY COR	INVENTORY ORDER/HYGIENE SUPPLIES	WRSH	01	NO REPORTING RI	647.03
PO23-00481	ESGI LLC	22-23 ESGI License Renewal	CURR	01	ESSER III ARP	8,904.00
PO23-00482	ELITE INTERACTIVE S	22/23 HH EXTERNAL SECURITY	M&O	01	NO REPORTING RI	26,551.00
PO23-00483	ELITE INTERACTIVE S	22/23 SQHS EXTERNAL SECURITY	M&O	01	NO REPORTING RI	21,636.96
PO23-00484	ELITE INTERACTIVE S	22/23 SCHS EXTERNAL SECURITY	M&O	01	NO REPORTING RI	22,356.92
PO23-00485	AMAZON CAPITAL SERV	ASES Materials & Supplies	GAEL	01	AFTER-SCHOOL E	1,000.00
PO23-00486	BENCHMARK EDUCATION	Curriculum-Elementary Phonics	EDSV	01	NO REPORTING RI	42,472.08
PO23-00487	BELLI ARCHITECTURAL	PALM ST PARKING LOT AND SAFTY LIGHTING	M&O	21	Bond A Secondar	8,033.44
PO23-00488	KNORR SYSTEMS	SQHS (TITAN POOL COVERS)	M&O	01	OTHER RESTRICT	26,837.69
PO23-00489	VERIZON CONNECT FLE	22/23 VEHICLE TRACKING SUBSCRIPTION	M&O	01	NO REPORTING RI	13,143.60
PO23-00490	GARY J GERY ARCHITE	MASTER PLAN UPDATE	M&O	25	OTHER RESTRICT	6,491.75
PO23-00491	BELLI ARCHITECTURAL	MASTER PLAN UPDATE	M&O	25	OTHER RESTRICT	50,000.00
PO23-00492	19SIX ARCHITECTS	MASTER PLAN UPDATE	M&O	25	OTHER RESTRICT	13,750.00
PO23-00493	BARTOS ARCHITECTURE	MASTER PLAN UPDATE	M&O	25	OTHER RESTRICT	39,400.00
PO23-00494	JB ELECTRIC & CONST	!STOP!*WL SWITCHGEAR REPLACMENT	M&O	21	Bond A Elem	88,224.16
PO23-00495	KENT CONSTRUCTION	*SQ FITNESS MOD SITE WORK	M&O	21	Bond A Secondar	194,511.21
PO23-00496	LEWIS & TIBBITS INC	*MHMS SWITCHGEAR REPLACEMENT	M&O	21	Bond A Secondar	108,719.01
PO23-00497	BELLI ARCHITECTURAL	HH FINE ART RENOVATION	M&O	21	Bond A Secondar	11,238.78
PO23-00498	BELLI ARCHITECTURAL	B40MS LIBRARY & ADMIN MOD	M&O	21	Bond A Secondar	69,194.87
PO23-00499	BELLI ARCHITECTURAL	B40MS STREET PRESENCE IMPROVEMENTS	M&O	21	Bond A Secondar	108,029.45
PO23-00500	BELLI ARCHITECTURAL	B40MS MUSIC/ MPR IMPROVEMENTS	M&O	21	Bond A Secondar	239,606.19
PO23-00501	MOBILE MODULAR MGMT	TRANSPORTATION TEMP HOUSING	M&O	21	Bond A Secondar	7,170.07
PO23-00502	KLEINFELDER INC	TRANSPORTATION BLDG INSPECTIONS	M&O	21	Bond A Secondar	33,296.05
PO23-00503	CAL WEST FENCE INC	*SQ NEW SECURITY FENCE	M&O	21	Bond A Secondar	5,869.65
PO23-00504	BELLI ARCHITECTURAL	HH FA BLDG MOD	M&O	21	Bond A Secondar	43,119.25
PO23-00505	MBC ENTERPRISES INC	!STOP!*SCH UNDERGROUND UTILITY REPLACEMENT	M&O	21	Bond A Secondar	281,353.71
PO23-00506	LOZANO SMITH LLP	Lozano Smith 6mo retainer	SUPT	01	NO REPORTING RI	188,000.00
PO23-00507	CDW GOVERNMENT INC.	DLV Trolley Cart (Goal 4, Strategy 3)	DLEL	01	LCFF SUPP FUNDI	753.83

The preceding Purchase Orders have been issued in accordance with the District's Purchasing Policy and authorization of the Board of Trustees. It is recommended that the preceding Purchase Orders be approved and that payment be authorized upon delivery and acceptance of the items ordered.

ESCAPE ONLINE

Page 17 of 19

Description

Includes Purchase Orders dated 06/04/2022 - 07/31/2022

PO Number	Vendor Name	Requisition Information	Ordr Loc	Req Fund	Resource Description	Req Fund Order Amt
PO23-00508	LEARNING WITHOUT TE	Workbooks K-3rd grade(Q-34263) Goal 3/Strategy 1	BVEL	01	LCFF SUPP FUNDI	2,882.43
PO23-00509	AMAZON CAPITAL SERV	Open-Monarch supplies. G1,A3	BSS	01	LCFF SUPP FUNDI	1,000.00
PO23-00510	AMAZON CAPITAL SERV	Open-CHS supplies. G1, A4.	BSS	01	NO REPORTING RI	1,000.00
PO23-00511	COAST PAPER & SUPPL	OPEN ORDER CUSTODIAL SUPPLIES	BVEL	01	NO REPORTING RI	2,000.00
PO23-00512	APPI	22/23 OPEN PO FOR POOL SUPPLIES	M&O	01	OTHER RESTRICT	6,000.00
PO23-00513	AIRGAS INC	22/23 OPEN PO FOR CO2 AT SCCS SWIMMING POOLS	M&O	01	OTHER RESTRICT	602.00
PO23-00514	KNORR SYSTEMS	22/23 OPEN PO FOR POOL SUPPLIES	M&O	01	OTHER RESTRICT	8,000.00
PO23-00515	LINCOLN AQUATICS	22/23 OPEN PO FOR POOL CHEMICALS	M&O	01	OTHER RESTRICT	12,000.00
PO23-00516	WESTSIDE PRODUCE	CFP/Cantaloupes	FS	13	CHLD NUTR:SCHO	240.00
PO23-00517	STAPLES ADVANTAGE	FS office supplies	FS	13	CHLD NUTR:SCHO	1,000.00
PO23-00518	COMMUNITY PRINTERS	Goals & Values Poster Printing	SUPT	01	NO REPORTING RI	318.70
PO23-00520	AMAZON CAPITAL SERV	LCFF Instructional Supplies	GAEL	01	LCFF SUPP FUNDI	3,500.00
PO23-00521	KNORR SYSTEMS	SCHS-CO2 FEED SYSTEM	M&O	01	OTHER RESTRICT	34,805.18
PO23-00522	KNORR SYSTEMS	22/23 ANNUAL HEATING SYSTEM MAINT. (HH&SCHS&SQHS)	M&O	01	OTHER RESTRICT	13,644.00
PO23-00523	CIVIC PERMITS INC	22/23 ANNUAL SUBSCRIPTION	M&O	01	OTHER RESTRICT	4,695.00
PO23-00524	CARBONIC SERVICE IN	22/23 OPEN PO FOR CO2 (Pools)	M&O	01	OTHER RESTRICT	600.00
PO23-00525	ABACHERLI FENCE CO	SQHS REPAIR JV BASEBALL FIELD BACKSTOP FENCING	M&O	01	OTHER RESTRICT	18,575.00
PO23-00526	PEARSON CLINICAL AS	OT ASSESSMENTS 22-23	SPED	01	SE:STATE LOCAL	1,290.52
PO23-00527	WPS	OT ASSESSMENTS 22-23	SPED	01	SE:STATE LOCAL	1,235.40
PO23-00528	THERAPRO INC	OT ASSESSMENTS 22-23	SPED	01	SE:STATE LOCAL	114.48
PO23-00529	MARIA E ARIAGNO BAL	CFP ESY 2022 APS-M. BALLARD: IEP MANDATED SERVICES	SPED	01	SE:STATE LOCAL	250.00
PO23-00530	PALACE BUSINESS SOL	22/23 SP.ED. DEPT MATERIALS/SUPPLIES	SPED	01	SE:STATE LOCAL	2,000.00
PO23-00531	AMAZON CAPITAL SERV	22/23 SP.ED. DEPT. MATERIALS/SUPPLIES - PSYCHS	SPED	01	SE:STATE LOCAL	800.00
PO23-00532	SMARTSIGN	PRINTING PARKING PASSES	SQHS	01	NO REPORTING RI	545.87
PO23-00533	AMAZON CAPITAL SERV	OPEN PO ADMIN OFFICE STORAGE CABINET	SQHS	01	NO REPORTING RI	1,000.00
PO23-00534	PALACE BUSINESS SOL	OPEN ORDER TO RESTOCK OFFICE SUPPLY CABINET	SQHS	01	NO REPORTING RI	1,000.00
PO23-00535	OFFICE DEPOT	OPEN ORDER ADMIN OFFICE STORAGE CABINET	SQHS	01	NO REPORTING RI	1,000.00
PO23-00536	STAPLES ADVANTAGE	COPY PAPER	SQHS	01	NO REPORTING RI	5,000.00
PO23-00537	BELLI ARCHITECTURAL	TRANSPORTATION TRAILER	M&O	21	Bond A Secondar	3,667.94
PO23-00538	AMAZON CAPITAL SERV	DW DOOR HRDWR SWITCHES	M&O	21	Bond A Secondar	2,601.20
PO23-00539	ID DISTRIBUTORS	DW KEY CARDS	M&O	21	Bond A Secondar	4,140.58
PO23-00540	DILBECK & SONS INC	SQ TV INSTALL	M&O	21	Bond A Secondar	51,690.00
PO23-00541	BOSCO CONSTRUCTION	HH RESTROOM PAINT	M&O	21	Bond A Secondar	41,337.00

The preceding Purchase Orders have been issued in accordance with the District's Purchasing Policy and authorization of the Board of Trustees. It is recommended that the preceding Purchase Orders be approved and that payment be authorized upon delivery and acceptance of the items ordered.

ESCAPE ONLINE

Description

Includes Purchase Orders dated 06/04/2022 - 07/31/2022

PO Number	Vendor Name	Requisition Information	Ordr Loc	Req Fund	Resource Description	Req Fund Order Amt
PO23-00542	PALACE BUSINESS SOL	Open PO Palace- Office Supplies (G1,S7)	DLEL	01	LCFF SUPP FUNDI	1,500.00
PO23-00543	AMAZON CAPITAL SERV	Open PO Amazon- Office (G1,S7)	DLEL	01	LCFF SUPP FUNDI	2,000.00
PO23-00544	STAPLES ADVANTAGE	Open PO for paper (G1,S7)	DLEL	01	LCFF SUPP FUNDI	2,400.00
PO23-00545	MISCOWATER	22/23 HH EMERGENCY TANK INSTALLATION	M&O	01	OTHER RESTRICT	3,300.00
PO23-00546	STAPLES ADVANTAGE	White copy paper	BMS	01	NO REPORTING RI	1,000.00
PO23-00547	AMAZON CAPITAL SERV	OPEN ORDER Classroom Supplies for Jeff Singson	BMS	01	NO REPORTING RI	650.00
PO23-00548	AMAZON.COM	OPEN ORDER/Supplies for Office	BMS	01	NO REPORTING RI	500.00
PO23-00549	ROSSI'S TOWING	FS Food truck maint	FS	13	CHLD NUTR:SCHO	50.00
PO23-00550	CSNA - CA SCHOOL NU	CONFIRMING FOR PAYMENT FS Memb. Renewal	FS	13	CHLD NUTR:SCHO	55.00
PO23-00551	ALPHAGRAPHICS SUNNY	office supplies	MHMS	01	NO REPORTING RI	1,500.00
PO23-00552	AMAZON.COM	office supplies	MHMS	01	NO REPORTING RI	2,000.00
PO23-00553	OFFICE DEPOT	open PO for office supplies	MHMS	01	NO REPORTING RI	1,500.00
PO23-00554	STAPLES ADVANTAGE	open PO for paper for classrooms	MHMS	01	NO REPORTING RI	2,000.00
PO23-00555	COMMUNITY PRINTERS	businesss cards for counseling department	MHMS	01	NO REPORTING RI	100.00
PO23-00556	PALACE BUSINESS SOL	office supplies	MHMS	01	NO REPORTING RI	500.00
PO23-00557	ACCURATE LABEL DESI	OPEN ORDER TO PRINT CUSTOM LABELS	MHMS	01	NO REPORTING RI	300.00
PO23-00558	AMAZON CAPITAL SERV	Open Admin supplies	BSS	01	NO REPORTING RI	500.00
PO23-00559	STAPLES ADVANTAGE	Open copy paper	BSS	01	NO REPORTING RI	1,000.00
PO23-00560	MONTI WASHINGTON DB	CSA FOR SPEAKER AT BACK TO SCHOOL ASSEMBLY	SCHS	01	NO REPORTING RI	2,375.00
PO23-00561	CHRISTOPHER FISHER	CSA FOR SPEAKER AT BACK TO SCHOOL ASSEMBLY	SCHS	01	NO REPORTING RI	2,375.00
PO23-00562	CDW GOVERNMENT INC.	IT Servers and Hard Drives	IT	01	NO REPORTING RI	1,520.60
					Total	40,523,298.57

The preceding Purchase Orders have been issued in accordance with the District's Purchasing Policy and authorization of the Board of Trustees. It is recommended that the preceding Purchase Orders be approved and that payment be authorized upon delivery and acceptance of the items ordered.

ESCAPE ONLINE

SANTA CRUZ CITY SCHOOL DISTRICT

AGENDA ITEM: Warrant Register

MEETING DATE: August 17, 2022

FROM: Jim Monreal, Assistant Superintendent, Business Services

THROUGH: Kris Munro, Superintendent

RECOMMENDATION:

Approve the warrants on the Board Payment Report. The report covers vendor warrants issued from 06/07/2022 through 07/31/2022.

AGENDA ITEM:

Checks Dated 06/07/2022 through 07/31/2022

Check Number	Check Date	Pay to the Order of	Check Amount
1002204	06/13/2022	APEX AUTO GLASS	170.00
1002205	06/13/2022	GRACIELA MARTINEZ	15.00
1002206	06/13/2022	JILL DONALSON	96.00
1002207	06/13/2022	LUIS SANCHEZ	10.00
1002208	06/13/2022	AMY WOODS	56.00
1002209	06/13/2022	CARLA SIKAND	168.00
1002210	06/13/2022	CHERYL ALLEN	56.00
1002211	06/13/2022	DAVID DELGADO	56.00
1002212	06/13/2022	DEBRA SILBERMAN	112.00
1002213	06/13/2022	EDDIE RHEE-PIZANO	56.00
1002214	06/13/2022	ESTRELLA FALKENROTH	112.00
1002215	06/13/2022	HELEN EWAN-STOREY	224.00
1002216	06/13/2022	INTERIOR VISION FLOORING & DESIGN	112.00
1002217	06/13/2022	JEANNE ALLSHOUSE	56.00
1002218	06/13/2022	JOANNE BEDFORD	56.00
1002219	06/13/2022	KRIS HOLDEN	56.00
1002220	06/13/2022	MARTHA HERNANDEZ	56.00
1002221	06/13/2022	MICHAEL WILSON	56.00
1002222	06/13/2022	MOLLY GRAESSLE	112.00
1002223	06/13/2022	NATHAN LONG	112.00
1002224	06/13/2022	NOVA COVINGTON-HALTER	56.00
1002225	06/13/2022	RAFAEL RAMIREZ	56.00
1002226	06/13/2022	RAFAEL RAMIREZ	112.00
1002227	06/13/2022	RICHARD SONNENBLICK	168.00
1002228	06/13/2022	SAMARA FOSTER	112.00
1002229	06/13/2022	SEAN TUTTMAN	56.00
1002230	06/13/2022	SHANA PHELAN	56.00
1002231	06/13/2022	SHARON BARNES	112.00
1002232	06/13/2022	SHERRIE HUETER	56.00
1002233	06/13/2022	TANYA BENNETT	56.00
1002234	06/13/2022	TARA MUCCILLI	56.00
1002235	06/13/2022	THOMAS TUPPER	56.00
1002236	06/13/2022	TONY VALDEZ	56.00
1002237	06/13/2022	VICTORIA CHOI	25.00
1002238	06/13/2022	ALPHAGRAPHICS SUNNYVALE	124.07
		Unpaid Tax	.13
		Expensed Amount	124.20
1002239	06/13/2022	AMAZON CAPITAL SERVICES	109.29
		Unpaid Tax	.63
		Expensed Amount	109.92
1002240	06/13/2022	BALL CHAIN MFG	464.31
1002241	06/13/2022	BEVERLY FABRICS	130.77
1002242	06/13/2022	CARDEA SERVICES	430.00
1002243	06/13/2022	COAST PAPER & SUPPLY	33.15
1002244	06/13/2022	COLLEGE BOARD, THE	5,932.00
1002245	06/13/2022	COMPLETE MAILING SERVICE INC	391.31
1002246	06/13/2022	DANIELSEN CO.	5,320.30
1002247	06/13/2022	DEMCO INC	140.01

The preceding Checks have been issued in accordance with the District's Policy and authorization of the Board of Trustees. It is recommended that the preceding Checks be approved.

ESCAPE ONLINE

Checks Dated 06/07/2022 through 07/31/2022

Check Number	Check Date	Pay to the Order of	Check Amount
1002248	06/13/2022	DOMINOS/3 AMIGOS PIZZA INC	1,845.00
1002249	06/13/2022	FLINN SCIENTIFIC INC	56.86
1002250	06/13/2022	FOLLETT CONTENT SOLUTIONS LLC	1,426.03
1002251	06/13/2022	GOLD STAR FOODS	8,399.13
1002252	06/13/2022	HARDWOODS SPECIALTY PRODUCTS US LP	63.81
1002253	06/13/2022	HARTFORD LIFE	3,086.67
1002254	06/13/2022	HSTRY LTD	500.00
1002255	06/13/2022	IDENTISYS INC	598.43
1002256	06/13/2022	JOSTENS INC	3,201.30
1002257	06/13/2022	KINGS PAINT & PAPER INC	272.39
1002258	06/13/2022	LUX BUS AMERICA	2,300.00
1002259	06/13/2022	M & M PARTY RENTALS INC	2,350.00
1002260	06/13/2022	MHB VOLLEYBALL CONSULTING SERV	850.00
1002261	06/13/2022	NATIONAL DEMOGRAPHICS INC	18,500.00
1002262	06/13/2022	OLIVER PACKAGING & EQUIPMENT	2,331.11
1002263	06/13/2022	P & R PAPER SUPPLY COMPANY INC	2,729.81
1002264	06/13/2022	PADLET	2,000.00
1002265	06/13/2022	PALACE BUSINESS SOLUTIONS	163.44
1002266	06/13/2022	PRODUCERS DAIRY FOODS INC	4,525.38
1002267	06/13/2022	RAY MORGAN CO.	246.40
1002268	06/13/2022	RDV CONSULTING SERVICES	6,000.00
1002269	06/13/2022	SAN LORENZO LUMBER AND HOME CENTER	360.47
1002270	06/13/2022	SANTA CRUZ SENTINEL	1,050.00
1002271	06/13/2022	SANTA CRUZ SOUND CO	575.00
1002272	06/13/2022	SCHOLASTIC INC.	1,258.60
1002273	06/13/2022	SCHOOL HEALTH CORPORATION	12.43
1002274	06/13/2022	SISC	508,691.80
1002275	06/13/2022	SOQUEL HIGH ASB	200.00
1002276	06/13/2022	SYSCO FOOD SERVICES OF SF	4,560.40
1002277	06/13/2022	THE HARTFORD LTD ATTN: GROUP BENEFITS	3,799.60
1002278	06/13/2022	UC REGENTS UC BERKELEY	30,000.00
1002279	06/13/2022	WATSONVILLE COAST PRODUCE	4,930.66
1002280	06/13/2022	Lampel, Alicia H	140.00
1002281	06/13/2022	Schutz, Matthew C	281.37
1002282	06/13/2022	Wedding, Katrina E	1,075.25
1002283	06/13/2022	Bettar, Brian K	108.97
1002284	06/13/2022	MacQuiddy McKee, Carol A	169.31
1002285	06/13/2022	Poirier, Michelle E	103.21
1002286	06/13/2022	Burke, Kathleen A	26.50
1002287	06/13/2022	Toschi, Dina R	230.24
1002288	06/13/2022	Hilderbrand, Laurie A	41.24
1002289	06/13/2022	Robles Vazquez, Nereyda R	35.94
1002290	06/13/2022	Thompson, Kathleen A	136.78
1002291	06/13/2022	ACE PORTABLE SERVICES	1,995.00
1002292	06/13/2022	APPI	262.16
1002293	06/13/2022	CINTAS CORPORATIONS	261.82
1002294	06/13/2022	COAST PAPER & SUPPLY	197.59
1002295	06/13/2022	ELITE INTERACTIVE SOLUTIONS LLC	2,066.67
1002296	06/13/2022	HOME DEPOT INC	1,849.46

The preceding Checks have been issued in accordance with the District's Policy and authorization of the Board of Trustees. It is recommended that the preceding Checks be approved.

ESCAPE ONLINE

Page 2 of 15

Checks Dated 06/07/2022 through 07/31/2022

Check Number	Check Date	Pay to the Order of	Check Amount
1002297	06/13/2022	INGENIUM GROUP LLC	6,128.24
1002298	06/13/2022	KELLY MOORE PAINT CO	49.97
1002299	06/13/2022	KELLY MOORE PAINT CO	104.31
1002300	06/13/2022	KELLY MOORE PAINT CO	56.23
1002301	06/13/2022	KONE INC	1,926.45
1002302	06/13/2022	LINCOLN AQUATICS	193.00
1002303	06/13/2022	OFFICE DEPOT	42.60
1002304	06/13/2022	SANTA CRUZ RECORDS MANAGEMENT	245.00
1002305	06/13/2022	SHERWIN WILLIAMS CO	86.21
1002306	06/13/2022	SANTA CRUZ CITY SCHOOLS REVOLVING	926.83
1002307	06/13/2022	DELTA CHARTER - CABRILLO	270,541.15
1002308	06/13/2022	19SIX ARCHITECTS	3,018.33
1002309	06/13/2022	COLBI TECHNOLOGIES INC	1,725.00
1002310	06/13/2022	CRW INDUSTRIES INC	95,441.75
1002311	06/13/2022	LEWIS & TIBBITS INC	12,840.98
1002312	06/13/2022	MONTEREY PENINSULA ENGINEERING	229,330.00
1002313	06/13/2022	MOORE TWINING ASSOCIATES INC	1,700.00
1002314	06/13/2022	PARK PLANET	670.00
1002315	06/13/2022	PREMIER INSPECTION SERVICES	5,175.00
1002316	06/13/2022	VERDE DESIGN INC	5,280.00
1002317	06/13/2022	ACCO BRANDS USA LLC	151.68
1002318	06/13/2022	ACSIG/EDGE DENTAL ATTN: K DENNIS, EXEC DIR	50,819.80
1002319	06/13/2022	AMAZON CAPITAL SERVICES	273.92
1002320	06/13/2022	BALANCE4KIDS	60,523.84
1002321	06/13/2022	BENCHMARK EDUCATION CO.	6,183.11
1002322	06/13/2022	BRIDGE WIRELESS INC	1,812.75
1002323	06/13/2022	CDW GOVERNMENT INC.	2,042.72
1002324	06/13/2022	COAST PAPER & SUPPLY	3,705.59
1002325	06/13/2022	FLAGS USA LLC	63.00
1002326	06/13/2022	FOLLETT CONTENT SOLUTIONS LLC	981.36
1002327	06/13/2022	GARY J GERY ARCHITECT	24,914.25
1002328	06/13/2022	OLIVER PACKAGING & EQUIPMENT	873.85
1002329	06/13/2022	PALACE BUSINESS SOLUTIONS	29.26
1002330	06/13/2022	PEGGY BARKER MS/ATP	2,137.50
1002331	06/13/2022	SANTA CRUZ COE	23,621.00
1002332	06/13/2022	SCHOLASTIC MAGAZINES INC.	271.42
1002333	06/13/2022	SG CONSULTING INC	62.50
1002334	06/13/2022	SPEECHRIGHTER INC	3,105.00
1002335	06/13/2022	STEPS TO SUCCESS	750.00
1002336	06/13/2022	SUZANNE BRAILLIER WEITZEL	320.91
1002337	06/13/2022	UC REGENTS PB SCI BO	2,100.00
1002338	06/13/2022	UCSC	600.00
1002339	06/13/2022	ULINE	1,158.11
		Unpaid Tax	.14-
		Expensed Amount	1,157.97
1002993	06/21/2022	DELAVEAGA ELEMENTARY	1,060.00
1002994	06/21/2022	B & B SMALL ENGINE REPAIR	2,056.98
1002995	06/21/2022	CALIFORNIA PREMIER RESTORATION	41,420.00
1002996	06/21/2022	CINTAS CORPORATIONS	308.65

The preceding Checks have been issued in accordance with the District's Policy and authorization of the Board of Trustees. It is recommended that the preceding Checks be approved.

ESCAPE ONLINE

Checks Dated 06/07/2022 through 07/31/2022

Check Number	Check Date	Pay to the Order of	Check Amount
1002997	06/21/2022	FERGUSON ENTERPRISES	76.28
1002998	06/21/2022	FLYERS ENERGY LLC	74.59
1002999	06/21/2022	HOME DEPOT INC	23.81
1003000	06/21/2022	INDEPENDENT ELECTRICAL SUPPLY	48.24
1003001	06/21/2022	SANTA CRUZ RECORDS MANAGEMENT	160.00
1003002	06/21/2022	SC SYSTEMS	250.00
1003003	06/21/2022	ULINE	1,262.96
		Unpaid Tax	.14-
		Expensed Amount	1,262.82
1003004	06/21/2022	AMY DAHLEN	292.00
1003005	06/21/2022	CHRIS FATHMAN	292.00
1003006	06/21/2022	BELENE RODRIGUEZ	56.00
1003007	06/21/2022	CALEB WOMACK	13.00
1003008	06/21/2022	EMRE TUNCER	56.00
1003009	06/21/2022	JESSE COWAN	56.00
1003010	06/21/2022	JILL DENNER	56.00
1003011	06/21/2022	MARK DEVINCENT	56.00
1003012	06/21/2022	MARK REED BARBOUR	56.00
1003013	06/21/2022	MIKE MCCALLUM	112.00
1003014	06/21/2022	MILLICENT FROST	56.00
1003015	06/21/2022	SARAH WOLFSEN	56.00
1003016	06/21/2022	THERESA PERRY	56.00
1003017	06/21/2022	TRISTAN REYES	26.00
1003018	06/21/2022	WILHELM ZILLIACUS	56.00
1003019	06/21/2022	ACES 2020 LLC	20,657.15
1003020	06/21/2022	ACSIG/VSP VISION CARE ATTN: K DENNIS, EXEC DIR	13,484.40
1003021	06/21/2022	ACTIVATE LEARNING LLC	1,500.00
1003022	06/21/2022	AMAZON CAPITAL SERVICES	4,745.93
		Unpaid Tax	.04-
		Expensed Amount	4,745.89
1003023	06/21/2022	APPLE COMPUTER INC	4,569.40
1003024	06/21/2022	BALANCE4KIDS	8,428.26
1003025	06/21/2022	BENCHMARK EDUCATION CO.	19,109.81
1003026	06/21/2022	CALIFORNIA DEPT OF JUSTICE ACCOUNTING OFFICE	655.00
1003027	06/21/2022	CDW GOVERNMENT INC.	29,251.91
1003028	06/21/2022	COAST PAPER & SUPPLY	54.34
1003029	06/21/2022	COMPLETE MAILING SERVICE INC	360.95
1003030	06/21/2022	COUNTY OF SANTA CRUZ ENVIRONMENTAL HEALTH	3,373.50
1003031	06/21/2022	CPM EDUCATIONAL PROGRAM	300.67
1003032	06/21/2022	DICK BLICK CO.	306.12
1003033	06/21/2022	EASTER SEALS CENTRAL CALIF	15,616.90
1003034	06/21/2022	FLYERS ENERGY LLC	4,038.03
1003035	06/21/2022	GOLD STAR FOODS	107.10
1003036	06/21/2022	GREENWASTE RECOVERY INC	6,833.04
1003037	06/21/2022	HOME DEPOT PRO	1,398.79
1003038	06/21/2022	JOHNSON GAS APPLIANCE CO	28.34
1003039	06/21/2022	LAKESHORE LEARNING MATERIALS	653.48
1003040	06/21/2022	LUNCHASSIST INC	5,000.00

The preceding Checks have been issued in accordance with the District's Policy and authorization of the Board of Trustees. It is recommended that the preceding Checks be approved.

ESCAPE ONLINE

Page 4 of 15

Checks Dated 06/07/2022 through 07/31/2022

Check Number	Check Date	Pay to the Order of	Check Amount
1003041	06/21/2022	PALACE BUSINESS SOLUTIONS	744.33
1003042	06/21/2022	PERMA BOUND DIVISION INC	621.85
1003043	06/21/2022	PHOENIX CERAMICS SUPPLY	69.09
1003044	06/21/2022	POSITIVE DISIPLINE COMMUNITY RESOURCES	3,500.00
1003045	06/21/2022	PRODUCERS DAIRY FOODS INC	659.05
1003046	06/21/2022	STAPLES ADVANTAGE	90.68
1003047	06/21/2022	SUTTER HEALTH PLUS	428,700.83
1003048	06/21/2022	TEACHERS PAY TEACHERS	5,100.00
1003049	06/21/2022	TEXTBOOK WAREHOUSE	2,624.18
1003050	06/21/2022	UNITED PARCEL SERVICE INC	81.10
1003051	06/21/2022	WATSONVILLE COAST PRODUCE	777.75
1003052	06/21/2022	ALBION ENVIRONMENTAL INC	7,998.44
1003053	06/21/2022	AMERICAN MODULAR SYSTEMS INC	380,599.45
1003054	06/21/2022	BARTOS ARCHITECTURE INC	37,840.00
1003055	06/21/2022	BELLI ARCHITECTURAL GROUP INC	2,370.24
1003056	06/21/2022	CREATIVE WINDOW INTERIORS INC	1,990.00
1003057	06/21/2022	DILBECK & SONS INC	39,851.55
1003058	06/21/2022	KLEINFELDER INC	4,991.00
1003059	06/21/2022	M3 ENVIRONMENTAL CONSULTING	6,750.00
1003060	06/21/2022	MOORE TWINING ASSOCIATES INC	1,067.00
1003061	06/21/2022	PSR ELECTRIC	24,141.00
1003062	06/21/2022	SANTA CRUZ SENTINEL	1,856.00
1003063	06/21/2022	BUSINESS CARD	16.26
1003064	06/21/2022	PHOENIX CERAMICS SUPPLY	989.59 *
Cancelled on 07/07/2022			
1003735	06/27/2022	ADRIANNA XILONZOCHILT	250.00
1003736	06/27/2022	GUADALUPE LICONA	250.00
1003737	06/27/2022	ISAIAH WILSON	250.00
1003738	06/27/2022	WILLOW VASSEUR	250.00
1003739	06/27/2022	Volpe, Joanne M	27.32
1003740	06/27/2022	Johnston, Jennifer L	40.10
1003741	06/27/2022	Moore, Laura A	90.25
1003742	06/27/2022	Angelacos, Jennifer L	32.00
1003743	06/27/2022	Cameron, Kristen A	113.36
1003744	06/27/2022	Tuson, Kim	21.59
1003745	06/27/2022	Hodges, Julia R	89.29
1003746	06/27/2022	Jolly, Kristyne R	5.91
1003747	06/27/2022	Weisman, Staci L	346.86
1003748	06/27/2022	Hernandez, Amariah A	1,062.48
1003749	06/27/2022	Oatey, Charlene P	92.31
1003750	06/27/2022	Boscacci, Peter R	138.35
1003751	06/27/2022	Shimasaki, Lindsay	6.88
1003752	06/27/2022	Weckler, Rosario	232.71
1003753	06/27/2022	Wedding, Katrina E	320.49
1003754	06/27/2022	Gerer, Jasmin I	122.35
1003755	06/27/2022	Kendall, Derek G	758.93
1003756	06/27/2022	Lal, Rishi D	230.90
1003757	06/27/2022	Uncapher, Erin	5.99
1003758	06/27/2022	Robertello, Meghan L	14.44

The preceding Checks have been issued in accordance with the District's Policy and authorization of the Board of Trustees. It is recommended that the preceding Checks be approved.

ESCAPE ONLINE

Page 5 of 15

Checks Dated 06/07/2022 through 07/31/2022

Check Number	Check Date	Pay to the Order of	Check Amount
1003759	06/27/2022	Duke, Krislynn S	28.90
1003760	06/27/2022	Toschi, Dina R	104.54
1003761	06/27/2022	Chew, Jason D	129.00
1003762	06/27/2022	Rovick, Leif L	138.30
1003763	06/27/2022	Vienna, Lori M	196.09
1003764	06/27/2022	Diaz, Rachel L	9.18
1003765	06/27/2022	Curley IV, Clyde J	168.79
1003766	06/27/2022	Haeger, Katrina E	209.91
1003767	06/27/2022	Jaffe, Jennifer A	84.86
1003768	06/27/2022	Norman, Holly A	198.82
1003769	06/27/2022	Semeniuk, Ellen	44.22
1003770	06/27/2022	CENTRAL VALLEY COMMUNITY BANK	2,383.75
1003771	06/27/2022	Oatey, Charlene P	160.87
1003772	06/27/2022	ACCO ENGINEERED SYSTEMS	18,549.00
1003773	06/27/2022	ACE PORTABLE SERVICES	114.62
1003774	06/27/2022	APPI	1,414.62
		Unpaid Tax	6.03-
		Expensed Amount	1,408.59
1003775	06/27/2022	B & B SMALL ENGINE REPAIR	370.59
1003776	06/27/2022	CARBONIC SERVICE INC	156.68
1003777	06/27/2022	CENTRAL HOME SUPPLY	2,009.72
1003778	06/27/2022	CINTAS CORPORATIONS	261.82
1003779	06/27/2022	COAST LOCK & SAFE	279.20
1003780	06/27/2022	COMCAST	281.52
1003781	06/27/2022	CRW INDUSTRIES INC	3,270.65
1003782	06/27/2022	CRYSTAL SPRINGS WATER	84.00
1003783	06/27/2022	DIRECT LINE TELE RESPONSE	114.00
1003784	06/27/2022	FLYERS ENERGY LLC	2,820.52
1003785	06/27/2022	HOME DEPOT INC	1,193.21
1003786	06/27/2022	KELLY MOORE PAINT CO	155.87
1003787	06/27/2022	KELLY MOORE PAINT CO	307.06
1003788	06/27/2022	M3 ENVIRONMENTAL CONSULTING	1,050.00
1003789	06/27/2022	MONTANO PLUMBING INC	5,383.20
1003790	06/27/2022	PACIFIC MATERIAL HANDLING SOLUTIONS	433.81
		Unpaid Tax	.31
		Expensed Amount	434.12
1003791	06/27/2022	RJMS CORPORATION DBA TOYOTA MATERIAL	330.00
1003792	06/27/2022	SANTA CRUZ RECORDS MANAGEMENT	220.70
1003793	06/27/2022	SURTEC INC	177.49
1003794	06/27/2022	TURF & INDUSTRIAL EQUIPMENT CO	12,665.91
1003795	06/27/2022	TWO STONE CABINETS AND TILE	87.25
1003796	06/27/2022	UNITED RENTALS	584.99
		Unpaid Tax	.09-
		Expensed Amount	584.90
1003797	06/27/2022	ABRITE ORGANIZATION, THE	100,399.26
1003798	06/27/2022	AMAZON CAPITAL SERVICES	104.11
1003799	06/27/2022	APPLE COMPUTER INC	597.01

The preceding Checks have been issued in accordance with the District's Policy and authorization of the Board of Trustees. It is recommended that the preceding Checks be approved.

ESCAPE ONLINE

Page 6 of 15

Checks Dated 06/07/2022 through 07/31/2022

Check Number	Check Date	Pay to the Order of	Check Amount
		Unpaid Tax <u>4.53</u>	
		Expensed Amount <u>601.54</u>	
1003800	06/27/2022	BALANCE4KIDS	2,664.14
1003801	06/27/2022	BAY SCHOOL, THE	59,710.06
1003802	06/27/2022	BENCHMARK EDUCATION CO.	2,069.49
1003803	06/27/2022	BRITE HORIZONS THE ABRITE ORGANIZATION	43,104.38
1003804	06/27/2022	BSN SPORTS LLC	4,822.36
1003805	06/27/2022	CALIFORNIANS TOGETHER	1,277.75
1003806	06/27/2022	CDW GOVERNMENT INC.	48,304.45
1003807	06/27/2022	COAST PAPER & SUPPLY	509.60
1003808	06/27/2022	EASTER SEALS CENTRAL CALIF	1,742.81
1003809	06/27/2022	FOLLETT CONTENT SOLUTIONS LLC	1,498.32
1003810	06/27/2022	KAISER FOUNDATION HEALTH PLAN	61,988.27
1003811	06/27/2022	LET ME LLC	1,387.50
1003812	06/27/2022	PALACE BUSINESS SOLUTIONS	2,663.84
1003813	06/27/2022	PBL WORKS	14,300.00
1003814	06/27/2022	SANTA CRUZ COE	28,519.00
1003815	06/27/2022	SC COUNTY SHERIFF - FISCAL	8,978.81
1003816	06/27/2022	SC ROLLER PALLADIUM EASTSIDE	496.00
1003817	06/27/2022	SOQUEL CREEK WATER DISTRICT	10,361.97
1003818	06/27/2022	SPEECHRIGHTER INC	2,300.00
1003819	06/27/2022	SPURR	59,383.79
1003820	06/27/2022	A & C GRADING INC	20,870.00
1003821	06/27/2022	BARTOS ARCHITECTURE INC	34,865.00
1003822	06/27/2022	BOSCO CONSTRUCTION SERVICES INC	9,605.00
1003823	06/27/2022	COMMUNICATION SERVICE CO	8,096.03
1003824	06/27/2022	DILBECK & SONS INC	79,446.32
1003825	06/27/2022	MBS ENGINEERING INC	3,279.36
1003826	06/27/2022	MOORE TWINING ASSOCIATES INC	162.50
1003827	06/27/2022	PSR ELECTRIC	42,343.00
1003828	06/27/2022	DIVISION OF STATE ARCHITECT	1,614.49
1003829	06/27/2022	JEFFREY N BOTTORFF	1,107.50
1004557	07/11/2022	ACCO ENGINEERED SYSTEMS	5,428.80
1004558	07/11/2022	ACE PORTABLE SERVICES	190.59
1004559	07/11/2022	ACTION AUTO GLASS	853.92
		Unpaid Tax <u>1.49</u>	
		Expensed Amount <u>855.41</u>	
1004560	07/11/2022	APPI	1,996.96
1004561	07/11/2022	C & N TRACTORS	385.27
1004562	07/11/2022	CINTAS CORPORATIONS	474.53
1004563	07/11/2022	COAST PAPER & SUPPLY	563.34
		Unpaid Tax <u>.09-</u>	
		Expensed Amount <u>563.25</u>	
1004564	07/11/2022	COMCAST	291.52
1004565	07/11/2022	CREATIVE WINDOW INTERIORS INC	960.00
1004566	07/11/2022	FIRST ALARM	120.00
1004567	07/11/2022	GOT GOPHERS INC	1,825.00
1004568	07/11/2022	HOME DEPOT INC	4,911.58

The preceding Checks have been issued in accordance with the District's Policy and authorization of the Board of Trustees. It is recommended that the preceding Checks be approved.

ESCAPE ONLINE

Checks Dated 06/07/2022 through 07/31/2022

Check Number	Check Date	Pay to the Order of	Check Amount
1004569	07/11/2022	INDEPENDENT ELECTRICAL SUPPLY	90.74
1004570	07/11/2022	KELLY MOORE PAINT CO	62.13
1004571	07/11/2022	KELLY MOORE PAINT CO	40.14
1004572	07/11/2022	KELLY MOORE PAINT CO	46.69
1004573	07/11/2022	KELLY MOORE PAINT CO	192.92
1004574	07/11/2022	LEWIS TREE SERVICE INC.	2,500.00
1004575	07/11/2022	LINCOLN AQUATICS	2,895.87
1004576	07/11/2022	RJMS CORPORATION DBA TOYOTA MATERIAL	12,566.89
1004577	07/11/2022	SANTA CRUZ RECORDS MANAGEMENT	135.00
1004578	07/11/2022	SUPERIOR ALARM CO	1,036.00
1004579	07/11/2022	ULINE	61.73
1004580	07/11/2022	KEVIN SANCHEZ ISMAEL	250.00
1004581	07/11/2022	STATE BOARD OF EQUALIZATION	96.00
1004582	07/11/2022	McKinney, Michelle L	58.74
1004583	07/11/2022	Chaput, Katherine V	600.00
1004584	07/11/2022	Cameron, Kristen A	31.01
1004585	07/11/2022	Cardenas, Alyssa L	39.19
1004586	07/11/2022	Calden, Shannon W	229.15
1004587	07/11/2022	Hodges, Julia R	35.80
1004588	07/11/2022	Lerman, Bernette M	23.75
1004589	07/11/2022	Munro, Kristin E	32.46
1004590	07/11/2022	Hernandez, Amariah A	313.08
1004591	07/11/2022	Martinez, Rosa O	117.06
1004592	07/11/2022	Schroeder, Erica	315.97
1004593	07/11/2022	Valdez, Jorge J	321.78
1004594	07/11/2022	Asamoto, Erin E	1,091.27
1004595	07/11/2022	Sturgeon, Rishelle C	10.41
1004596	07/11/2022	ACE PORTABLE SERVICES	690.00
1004597	07/11/2022	AT&T	2,237.59
1004598	07/11/2022	BENCHMARK EDUCATION CO.	6,202.79
1004599	07/11/2022	CDW GOVERNMENT INC.	1,514.37
1004600	07/11/2022	CHARTWELL SCHOOL	1,378.44
1004601	07/11/2022	Culver, Joseph C	581.00
1004602	07/11/2022	Lopez, Teodoro	87.80
1004603	07/11/2022	Vanderplas, Justyn F	52.05
1004604	07/11/2022	Quevedo, Eva V	158.14
1004605	07/11/2022	Gomez, Vince C	73.97
1004606	07/11/2022	Manners, Wednesday R	7.48
1004607	07/11/2022	Martinez, Alyssa M	25.15
1004608	07/11/2022	Hedrick-Farr, Amy R	858.71
1004609	07/11/2022	Hernandez, Amariah A	543.31
1004610	07/11/2022	Asamoto, Erin E	199.98
1004611	07/11/2022	Burke, Kathleen A	68.62
1004612	07/11/2022	Bentley, Thomas K	465.93
1004613	07/11/2022	Wilson, Diana M	45.51
1004614	07/11/2022	Higgins, Tamara H	727.39
1004615	07/11/2022	Hagood, Linda G	198.01
1004616	07/11/2022	ANAYA CONSTRUCTION	38,800.00
1004617	07/11/2022	BELLI ARCHITECTURAL GROUP INC	4,891.02

The preceding Checks have been issued in accordance with the District's Policy and authorization of the Board of Trustees. It is recommended that the preceding Checks be approved.

ESCAPE ONLINE

Page 8 of 15

Checks Dated 06/07/2022 through 07/31/2022

Check Number	Check Date	Pay to the Order of	Check Amount
1004618	07/11/2022	CYCLONE FENCE & IRON INC	31,818.58
1004619	07/11/2022	FIBER OPTIC TELECOM INTL	1,480.00
1004620	07/11/2022	KENT CONSTRUCTION	88,796.09
1004621	07/11/2022	LEACH GROUP INC	3,900.00
1004622	07/11/2022	MONTEREY PENINSULA ENGINEERING	122,550.00
1004623	07/11/2022	PREMIER INSPECTION SERVICES	7,130.00
1004624	07/11/2022	ABRITE ORGANIZATION, THE	97,005.61
1004625	07/11/2022	AMANDA PACKER	3,630.00
1004626	07/11/2022	AMAZON CAPITAL SERVICES	57.72
1004627	07/11/2022	AMS.NET C/O FREMONT BANK	29,780.84
1004628	07/11/2022	CHARTWELL SCHOOL	7,139.44
1004629	07/11/2022	COAST PAPER & SUPPLY	7,403.80
1004630	07/11/2022	CRUZIO	49.95
1004631	07/11/2022	DIESELWORKS	5,563.00
1004632	07/11/2022	EDFILES INC	5,814.00
1004633	07/11/2022	FLYERS ENERGY LLC	995.56
1004634	07/11/2022	FREE STYLE SALES CO	593.42
		Unpaid Tax	6.60
		Expensed Amount	600.02
1004635	07/11/2022	GS DIRECT LLC	9,585.85
1004636	07/11/2022	HCI AUDIOMETRICS - A/R	700.07
1004637	07/11/2022	INTERNATIONAL BACCALAUREATE OR	11,800.00
1004638	07/11/2022	JEFFREY N BOTTORFF	500.00
1004639	07/11/2022	LOZANO SMITH LLP	40,000.00
1004640	07/11/2022	MHB VOLLEYBALL CONSULTING SERV	780.00
1004641	07/11/2022	NORTH BAY FORD	894.31
1004642	07/11/2022	NOURISHING GENERATIONS ED PROG	2,000.00
1004643	07/11/2022	OFFICE DEPOT	10.47
1004644	07/11/2022	P&A ADMINISTRATIVE SERVICES	182.50
1004645	07/11/2022	PALACE BUSINESS SOLUTIONS	5,337.92
1004646	07/11/2022	PEGGY BARKER MS/ATP	2,512.50
1004647	07/11/2022	SANTA CRUZ MUNICIPAL UTILITIES	46,604.89
1004648	07/11/2022	SANTA CRUZ, CITY OF	519.66
1004649	07/11/2022	SCHOOL OUTFITTERS	751.78
		Unpaid Tax	1.28
		Expensed Amount	753.06
1004650	07/11/2022	SCHOOL SERVICES OF CALIF	275.00
1004651	07/11/2022	SOFTCHOICE CORPORATION	34,631.13
1004652	07/11/2022	SOLAR ENERGY OF AMERICA LLC	7,935.05
1004653	07/11/2022	SOLARCITY LMC SERIES 1 LLC	5,694.96
1004654	07/11/2022	SOQUEL CREEK WATER DISTRICT	93.94
1004655	07/11/2022	STAPLES ADVANTAGE	859.36
1004656	07/11/2022	STATE OF CALIFORNIA DEPARTMENT OF REHABILITATION	19,749.75
1004657	07/11/2022	T-MOBILE USA INC	3,223.36
1004658	07/11/2022	WINCHESTER SOQUEL DBA NAPA AUTO PARTS	184.74
1004659	07/11/2022	ARBITERPAY TRUST ACCOUNT BANK OF UTAH	26,500.00
1004660	07/11/2022	MALACHIED, INC DBA THE BREAKTHROUGH COACH	2,475.00
1004661	07/11/2022	MISSION HILL BLDG OWNERS ASSN	15,945.94

The preceding Checks have been issued in accordance with the District's Policy and authorization of the Board of Trustees. It is recommended that the preceding Checks be approved.

ESCAPE ONLINE

Checks Dated 06/07/2022 through 07/31/2022

Check Number	Check Date	Pay to the Order of	Check Amount
1004662	07/11/2022	SANTANDER LEASING LLC	13,432.00
1004663	07/11/2022	SANTA CRUZ CITY SCHOOLS REVOLVING	600.59
1004664	07/11/2022	AMAZON CAPITAL SERVICES	17.69
1004665	07/11/2022	COALITION FOR ADEQUATE SCHOOLS	650.00
1004666	07/11/2022	DANIEL JOHN SIDDENS	1,254.00
1004667	07/11/2022	FRONTLINE TECHNOLOGIES GROUP DBA FRONTLINE EDUCATION	13,692.14
1004668	07/11/2022	HANDLE WITH CARE BEHAVIOR MANAGEMENT SYSTEMS INC	1,375.00
1004669	07/11/2022	ACE PORTABLE SERVICES	1,238.92
1004670	07/11/2022	ALBION ENVIRONMENTAL INC	6,116.24
1004671	07/11/2022	ART GRAMS INSPECTION SERVICES	5,000.00
1004672	07/11/2022	ATLANTIS PAVING & GRADING	51,204.05
1004673	07/11/2022	AV NOW INC	74,065.01
1004674	07/11/2022	BELLI ARCHITECTURAL GROUP INC	376.25
1004675	07/11/2022	CRW INDUSTRIES INC	437,316.35
1004676	07/11/2022	GARY J GERY ARCHITECT	17,094.00
1004677	07/11/2022	JB ELECTRIC & CONSTRUCTION INC	29,887.00
1004678	07/11/2022	KLEINFELDER INC	3,650.00
1004679	07/11/2022	LEWIS & TIBBITS INC	57,617.50
1004680	07/11/2022	SANTA CLARA VALLEY CONSTRUCTION INSPECTIONS	8,000.00
1004681	07/11/2022	VERDE DESIGN INC	3,664.50
1004682	07/11/2022	ACES 2020 LLC	16,509.62
1004683	07/11/2022	ALL BAY MECHANICAL INC	675.00
1004684	07/11/2022	AMAZON CAPITAL SERVICES	1,180.07
1004685	07/11/2022	BAY SCHOOL, THE	22,056.32
1004686	07/11/2022	BSN SPORTS LLC	999.71
1004687	07/11/2022	CDW GOVERNMENT INC.	4,878.95
1004688	07/11/2022	COMPLETE MAILING SERVICE INC	820.45
1004689	07/11/2022	DICK BLICK CO.	11.84
1004690	07/11/2022	EAN SERVICES LLC	2,513.30
1004691	07/11/2022	EASTER SEALS CENTRAL CALIF	4,495.51
1004692	07/11/2022	FLYERS ENERGY LLC	3,456.56
1004693	07/11/2022	MILLER MAXFIELD INC	787.50
1004694	07/11/2022	SANTA CRUZ COUNTY PARKS DEPT	408.50
1004695	07/11/2022	SANTA CRUZ MUNICIPAL UTILITIES	94.27
1004696	07/11/2022	STAPLES ADVANTAGE	128.90
1004697	07/11/2022	STEPS TO SUCCESS	687.50
1004698	07/11/2022	T-MOBILE USA INC	115.92
1004699	07/11/2022	VISTA HIGHER LEARNING INC	819.09
1004700	07/11/2022	WINCHESTER SOQUEL DBA NAPA AUTO PARTS	258.89
1004701	07/11/2022	E.D.D./ STATE OF CALIFORNIA	59,658.58
1005170	07/18/2022	19SIX ARCHITECTS	2,460.00
1005171	07/18/2022	BARTOS ARCHITECTURE INC	38,786.28
1005172	07/18/2022	BELLI ARCHITECTURAL GROUP INC	14,185.20
1005173	07/18/2022	CAL WEST FENCE INC	111,523.35
1005174	07/18/2022	COLBI TECHNOLOGIES INC	1,035.00
1005175	07/18/2022	HANCOCK PARK & DELONG INC.	3,787.50
1005176	07/18/2022	KENT CONSTRUCTION	196,358.79

The preceding Checks have been issued in accordance with the District's Policy and authorization of the Board of Trustees. It is recommended that the preceding Checks be approved.

ESCAPE ONLINE

Page 10 of 15

Checks Dated 06/07/2022 through 07/31/2022

Check Number	Check Date	Pay to the Order of	Check Amount
1005177	07/18/2022	KLEINFELDER INC	2,729.00
1005178	07/18/2022	MOBILE MODULAR MGMT CORP	689.71
1005179	07/18/2022	SOLAR ENERGY OF AMERICA LLC	27,723.00
1005180	07/18/2022	VERDE DESIGN INC	5,280.00
1005181	07/18/2022	AA SAFE & LOCK COMPANY	247.18
1005182	07/18/2022	ACCO ENGINEERED SYSTEMS	495.00
1005183	07/18/2022	ACE PORTABLE SERVICES	1,262.29
1005184	07/18/2022	AMAZON CAPITAL SERVICES	180.93
1005185	07/18/2022	APPI	767.92
1005186	07/18/2022	B & B SMALL ENGINE REPAIR	154.60
1005187	07/18/2022	CENTRAL COAST SYSTEMS INC	15,593.50
1005188	07/18/2022	CINTAS CORPORATIONS	49.11
1005189	07/18/2022	COAST PAPER & SUPPLY	1,062.20
1005190	07/18/2022	CRYSTAL SPRINGS WATER	58.31
1005191	07/18/2022	EWING IRRIGATION PRODUCTS	3,116.44
1005192	07/18/2022	FLYERS ENERGY LLC	5,777.67
1005193	07/18/2022	HINES PEST & WEED CONTROL DBA R AURIA INC	205.00
1005194	07/18/2022	HOME DEPOT INC	1,301.95
1005195	07/18/2022	INDEPENDENT ELECTRICAL SUPPLY	290.81
1005196	07/18/2022	KNORR SYSTEMS	1,560.81
1005197	07/18/2022	LINCOLN AQUATICS	657.15
1005198	07/18/2022	MOBILE MODULAR MGMT CORP	27,387.04
1005199	07/18/2022	PALACE BUSINESS SOLUTIONS	604.16
1005200	07/18/2022	PLOW & HEARTH	127.23
1005201	07/18/2022	RIVERSIDE LIGHTING	144.98
1005202	07/18/2022	SAN LORENZO LUMBER AND HOME CENTER	1,722.79
1005203	07/18/2022	SC SYSTEMS	500.00
1005204	07/18/2022	SAN LORENZO LUMBER AND HOME CENTER	109.49
1005205	07/18/2022	AMAZON CAPITAL SERVICES	11,375.19
		Unpaid Tax	.23-
		Expensed Amount	11,374.96
1005206	07/18/2022	19SIX ARCHITECTS	41,250.00
1005207	07/18/2022	BARTOS ARCHITECTURE INC	10,900.00
1005208	07/18/2022	BELLI ARCHITECTURAL GROUP INC	10,000.00
1005209	07/18/2022	SC SYSTEMS	10,000.00
1005210	07/18/2022	Laszlo Rath, Michelle A	41.30
1005211	07/18/2022	Jolly, Kristyne R	21.06
1005212	07/18/2022	Weisman, Staci L	196.80
1005213	07/18/2022	Boscacci, Peter R	16.97
1005214	07/18/2022	Juarez, Consuelo	27.20
1005215	07/18/2022	A SIGN ASAP	164.63
1005216	07/18/2022	AMAZON CAPITAL SERVICES	1,675.59
1005217	07/18/2022	BAY AREA FLOORS & INTERIORS	3,493.00
1005218	07/18/2022	BOARDWALK BOWL	234.00
1005219	07/18/2022	BRIGHTLY SOFTWARE INC	7,063.31
1005220	07/18/2022	COAST PAPER & SUPPLY	225.00
1005221	07/18/2022	CODESP	2,300.00
1005222	07/18/2022	CSPCA DOWNEY UNIFIED SCHOOL DIST	700.00
1005223	07/18/2022	CURRICULUM ASSOCIATES INC	73,962.00

The preceding Checks have been issued in accordance with the District's Policy and authorization of the Board of Trustees. It is recommended that the preceding Checks be approved.

ESCAPE ONLINE

Checks Dated 06/07/2022 through 07/31/2022

Check Number	Check Date	Pay to the Order of	Check Amount
1005224	07/18/2022	E3 DIAGNOSTICS INC. - A/R	106.77
		Unpaid Tax <u>1.38</u>	
		Expensed Amount <u>108.15</u>	
1005225	07/18/2022	HANDLE WITH CARE BEHAVIOR MANAGEMENT SYSTEMS INC	1,375.00
1005226	07/18/2022	KELLY MOORE PAINT CO	158.86
1005227	07/18/2022	KELLY MOORE PAINT CO	162.75
1005228	07/18/2022	KELLY MOORE PAINT CO	737.38
1005229	07/18/2022	OFFICE DEPOT	18.90
1005230	07/18/2022	PALACE BUSINESS SOLUTIONS	52.79
1005231	07/18/2022	PRIORS TIRES	236.06
1005232	07/18/2022	ROTARY CLUB OF SANTA CRUZ	2,600.00
1005233	07/18/2022	THE ORIGINS PROGRAM	1,710.00
1005234	07/18/2022	THE PRINT GALLERY	604.70
1005235	07/18/2022	TYPING AGENT LLC	2,520.00
1005236	07/18/2022	UC REGENTS UCSC	750.00
1005237	07/18/2022	ULINE	56.43
		Unpaid Tax <u>.14-</u>	
		Expensed Amount <u>56.29</u>	
1005238	07/18/2022	ABRITE ORGANIZATION, THE	27,150.01
1005239	07/18/2022	ACSA C/O BOXWOOD TECH INC	288.00
1005240	07/18/2022	ADVANCED BLIND & SHADE	275.00
1005241	07/18/2022	AMAZON CAPITAL SERVICES	1,325.83
1005242	07/18/2022	AMS.NET C/O FREMONT BANK	63,112.76
1005243	07/18/2022	APPLE COMPUTER INC	439.66
1005244	07/18/2022	AT&T	1,167.66
1005245	07/18/2022	BALANCE4KIDS	22,380.02
1005246	07/18/2022	BAY SCHOOL, THE	64,148.06
1005247	07/18/2022	BENCHMARK EDUCATION CO.	5,281.53
1005248	07/18/2022	BIOMETRICS4ALL INC	124.00
1005249	07/18/2022	BOARDWALK BOWL	105.00
1005250	07/18/2022	BOXWOOD TECHNOLOGY INC BDA ACS A	1,436.00
1005251	07/18/2022	BRITE HORIZONS THE ABRITE ORGANIZATION	24,975.00
1005252	07/18/2022	CALIFORNIA DEPT OF JUSTICE ACCOUNTING OFFICE	1,075.00
1005253	07/18/2022	CDW GOVERNMENT INC.	24,713.81
1005254	07/18/2022	CHARTWELL SCHOOL	3,000.00
1005255	07/18/2022	COAST LOCK & SAFE	124.60
1005256	07/18/2022	CONSOLIDATED PLUMBING INC	4,671.88
1005257	07/18/2022	DANNIS WOLIVER KELLEY	472.00
1005258	07/18/2022	DEMCO INC	86.92
1005259	07/18/2022	DEVELOPMENT GROUP INC	6,144.44
1005260	07/18/2022	EAN SERVICES LLC	1,248.55
1005261	07/18/2022	FAGEN FRIEDMAN & FULFROST LLP	3,152.50
1005262	07/18/2022	FEDEX OFFICE	1,089.33
1005263	07/18/2022	GREENBACKER DBA MAGNOLIA SUN LLC	8,611.27
1005264	07/18/2022	GREENWASTE RECOVERY INC	6,833.04
1005265	07/18/2022	HEINEMANN	1,035.79
1005266	07/18/2022	JUNIOR LIBRARY GUILD	2,616.45
1005267	07/18/2022	KATIE EICHOLZ	1,607.76

The preceding Checks have been issued in accordance with the District's Policy and authorization of the Board of Trustees. It is recommended that the preceding Checks be approved.

ESCAPE ONLINE

Checks Dated 06/07/2022 through 07/31/2022

Check Number	Check Date	Pay to the Order of	Check Amount
1005268	07/18/2022	KNORR SYSTEMS	1,210.00
1005269	07/18/2022	LEARNING WITHOUT TEARS	1,168.68
1005270	07/18/2022	LUX BUS AMERICA	95.00
1005271	07/18/2022	MARCY COOK DBA MARCY COOK MATH	290.64
1005272	07/18/2022	MEDICAL BILLING TECHNOLOGIES	600.00
1005273	07/18/2022	NASCO	1,290.23
1005274	07/18/2022	OFFICE DEPOT	1,505.00
1005275	07/18/2022	PALACE BUSINESS SOLUTIONS	115.47
1005276	07/18/2022	PBL WORKS	5,000.00
1005277	07/18/2022	PRIORS TIRES	25.00
1005278	07/18/2022	RIO GRANDE ALBUQUERQUE INC.	173.71
1005279	07/18/2022	SAN LORENZO LUMBER AND HOME CENTER	289.70
1005280	07/18/2022	SANTA CRUZ COE	9,174.00
1005281	07/18/2022	SANTA CRUZ RECORDS MANAGEMENT	45.00
1005282	07/18/2022	SANTA CRUZ, CITY OF	616.35
1005283	07/18/2022	SCHOOL OUTFITTERS	1,192.44
		Unpaid Tax	2.73
		Expensed Amount	1,195.17
1005284	07/18/2022	SCHOOL SERVICES OF CALIF	1,000.00
1005285	07/18/2022	SOQUEL CREEK WATER DISTRICT	11,027.19
1005286	07/18/2022	SPEECHRIGHTER INC	15,237.50
1005287	07/18/2022	SPURR	56,291.21
1005288	07/18/2022	T-MOBILE USA INC	2,457.34
1005289	07/18/2022	VISTA HIGHER LEARNING INC	2,448.87
1005290	07/18/2022	ABRITE ORGANIZATION, THE	3,563.69
1005291	07/18/2022	AMAZON CAPITAL SERVICES	163.89
1005292	07/18/2022	ACSIG/EDGE DENTAL ATTN: K DENNIS, EXEC DIR	54,176.70
1005293	07/18/2022	ACSIG/VSP VISION CARE ATTN: K DENNIS, EXEC DIR	6,757.40
1005294	07/18/2022	SISC	519,432.60
1005673	07/25/2022	BUSINESS CARD	510.32
1005674	07/25/2022	NIKE VOLLEYBALL CAMPS ATTN:SIERRA LOVE	1,175.00
1005675	07/25/2022	SANTA CRUZ CITY SCHOOLS REVOLVING	16,314.53
1005676	07/25/2022	DELTA CHARTER - CABRILLO	122,968.08
1005677	07/25/2022	BELLI ARCHITECTURAL GROUP INC	3,319.23
1005678	07/25/2022	MBC ENTERPRISES INC	108,535.45
1005679	07/25/2022	MOBILE MODULAR MGMT CORP	689.71
1005680	07/25/2022	ABACHERLI FENCE CO	20,665.00
1005681	07/25/2022	ACE PORTABLE SERVICES	1,238.92
1005682	07/25/2022	ALBION ENVIRONMENTAL INC	23,540.70
1005683	07/25/2022	COLBI TECHNOLOGIES INC	30,000.00
1005684	07/25/2022	CYCLONE FENCE & IRON INC	14,081.80
1005685	07/25/2022	DILBECK & SONS INC	2,217.51
1005686	07/25/2022	LEACH GROUP INC	2,080.00
1005687	07/25/2022	BUSINESS CARD	2,840.94
1005688	07/25/2022	HEINEMANN	2,679.35
1005689	07/25/2022	MOBILE MODULAR MGMT CORP	13,589.17
1005690	07/25/2022	OKAPI EDUCATIONAL PUBLISHING INC	1,672.42
1005691	07/25/2022	PACIFIC COAST TRANE - A/R	85,877.50
1005692	07/25/2022	PALACE BUSINESS SOLUTIONS	9.31

The preceding Checks have been issued in accordance with the District's Policy and authorization of the Board of Trustees. It is recommended that the preceding Checks be approved.

ESCAPE ONLINE

Page 13 of 15

Checks Dated 06/07/2022 through 07/31/2022

Check Number	Check Date	Pay to the Order of	Check Amount
1005693	07/25/2022	SANTA CRUZ COE	14,540.00
1005694	07/25/2022	SCOTTS VALLEY USD	1,000.00
1005695	07/25/2022	UCSC-REGENTS FINANCIAL SERVICE CENTER	273.00
1005696	07/25/2022	ABA BUILDING SERVICES	3,975.00
1005697	07/25/2022	AMAZON CAPITAL SERVICES	227.81
1005698	07/25/2022	AMERICAN RED CROSS TRAINING SERVICES	1,181.42
1005699	07/25/2022	AT&T	1,069.93
1005700	07/25/2022	AT&T	2,902.63
1005701	07/25/2022	CANON FINANCIAL SERVICES INC	25,058.08
1005702	07/25/2022	CATAPULTK12	10,843.30
1005703	07/25/2022	CINTAS CORPORATIONS	342.87
1005704	07/25/2022	COAST PAPER & SUPPLY	74.84
1005705	07/25/2022	CROWE LLP	26,000.00
1005706	07/25/2022	CSBA	23,010.00
1005707	07/25/2022	FERGUSON ENTERPRISES	1,539.84
1005708	07/25/2022	INDEPENDENT ELECTRICAL SUPPLY	398.83
		Unpaid Tax	.91
		Expensed Amount	399.74
1005709	07/25/2022	KELLY MOORE PAINT CO	15.82
1005710	07/25/2022	KELLY MOORE PAINT CO	53.99
1005711	07/25/2022	MEDICAL BILLING TECHNOLOGIES	13,500.00
1005712	07/25/2022	PALACE BUSINESS SOLUTIONS	139.72
1005713	07/25/2022	PRIORS TIRES	236.06
1005714	07/25/2022	RAY MORGAN CO.	132.67
1005715	07/25/2022	RENAISSANCE LEARNING INC	1,595.00
1005716	07/25/2022	SAN LORENZO LUMBER AND HOME CENTER	1,212.93
1005717	07/25/2022	SANTA CRUZ MUNICIPAL UTILITIES	8,085.67
1005718	07/25/2022	SANTA CRUZ RECORDS MANAGEMENT	45.00
1005719	07/25/2022	SCHOOL INNOVATIONS & ACHIEVEMENT	16,500.00
1005720	07/25/2022	SUPERIOR ALARM CO	3,274.00
1005721	07/25/2022	SUTTER HEALTH PLUS	412,794.16
ACH-00045232	07/08/2022	Kiauna R. Day Smith	1,539.16 *

Cancelled on 07/27/2022

Total Number of Checks 623 7,578,684.06

	Count	Amount
Cancel	2	2,528.75
Net Issue		<u>7,576,155.31</u>

Fund Recap

Fund	Description	Check Count	Expensed Amount
01	GENERAL/COUNTY SCHOOL	524	4,650,158.78
11	ADULT EDUCATION	2	429.48
13	CAFETERIA SPECIAL REVENUE	15	43,516.68
21	BUILDING	73	2,377,640.09
25	CAPITAL FACILITIES	9	188,186.67
40	SPL RESV CAPITAL OUTLAY PRJ	16	315,736.70
73	FOUNDATION PRIVATE-PURPOSE TRU	2	500.00

The preceding Checks have been issued in accordance with the District's Policy and authorization of the Board of Trustees. It is recommended that the preceding Checks be approved.

ESCAPE ONLINE

Checks Dated 06/07/2022 through 07/31/2022

Check Number	Check Date	Pay to the Order of	Check Amount
		Total Number of Checks	621
			7,576,168.40
		Less Unpaid Tax Liability	13.09
		Net (Check Amount)	7,576,155.31

The preceding Checks have been issued in accordance with the District's Policy and authorization of the Board of Trustees. It is recommended that the preceding Checks be approved.

ESCAPE ONLINE

Page 15 of 15

SANTA CRUZ CITY SCHOOL DISTRICT

AGENDA ITEM: Budget Transfers

MEETING DATE: August 17, 2022

FROM: Jim Monreal, Assistant Superintendent Business Services

THROUGH: Kris Munro, Superintendent

RECOMMENDATION:

Approve 22-23 budget transfers dated from 04/14/22 through 07/29/22. The report follows.

BACKGROUND:

Ed Code 42600 requires that the Board approve budget transfers that are made between major expense object codes, or from reserves.

FISCAL IMPACT:

None.

This work is in direct support of the following District goal and its corresponding metrics:

Goal #5: SCCS will maintain a balanced budget and efficient and effective management.

Effective 04/14/2022 through 07/29/2022

Fiscal Year 2022

Account	Description	Comment	From	To
JE # BR22-01564 JE Trans Date 06/01/2022 JE Posted 06/01/2022 Comment JL-For Custodial Invoice				
(001454) 01-0000-0-0000-8200-4300-832-0000	NO REPORTING RE,MATERI	CR		267.00
(001384) 01-0000-0-0000-8200-3312-832-0000	NO REPORTING RE,FICA:CL	DR	267.00	
			267.00	267.00
JE # BR22-01565 JE Trans Date 06/01/2022 JE Posted 06/01/2022 Comment COVER OVRAGE ON PO				
(015718) 01-0809-0-6000-1000-4300-830-0809	Measure T,MATERIALS & SU	DR	20.00	
(032011) 01-0809-0-6000-1000-5600-830-0809	Measure T,RENTAL/LEASE/R	CR		20.00
			20.00	20.00
JE # BR22-01566 JE Trans Date 06/01/2022 JE Posted 06/01/2022 Comment JB-GRADUATION RENTAL				
(000575) 01-0000-0-0000-2700-4300-834-0014	NO REPORTING RE,MATERI	DR	565.00	
(000597) 01-0000-0-0000-2700-5600-834-0014	NO REPORTING RE,RENTAL	CR		565.00
			565.00	565.00
JE # BR22-01567 JE Trans Date 06/01/2022 JE Posted 06/01/2022 Comment BD-ATTENDANCE TECH OT EWR				
(000392) 01-0000-0-0000-2700-2490-835-0000	NO REPORTING RE,CLASS (CR		907.00
(000440) 01-0000-0-0000-2700-3312-835-0000	NO REPORTING RE,FICA:CL	CR		56.00
(000471) 01-0000-0-0000-2700-3332-835-0000	NO REPORTING RE,MEDICA	CR		13.00
(000524) 01-0000-0-0000-2700-3502-835-0000	NO REPORTING RE,STATE I	CR		5.00
(000554) 01-0000-0-0000-2700-3602-835-0000	NO REPORTING RE,WORKE	CR		18.00
(000389) 01-0000-0-0000-2700-2440-835-0000	NO REPORTING RE,CLASS (DR	999.00	
			999.00	999.00
JE # BR22-01568 JE Trans Date 06/01/2022 JE Posted 06/01/2022 Comment JL-BSSC Replacement Supplies				
(016112) 01-0000-0-3100-1000-4300-825-0004	NO REPORTING RE,MATERI	CR		6,800.00
(032012) 01-0000-0-3300-1000-4100-837-0004	NO REPORTING RE,APPR TI	CR		500.00
(032013) 01-0000-0-3200-1000-4100-836-0004	NO REPORTING RE,APPR TI	CR		500.00
			Net increase to Appropriations	7,800.00
JE # BR22-01569 JE Trans Date 06/01/2022 JE Posted 06/01/2022 Comment YEARBOOK				
(029465) 01-9010-0-1360-1000-4300-034-3456	OTHER RESTRICTE,MATERI	DR	6,870.00	
(032016) 01-9010-0-1360-1000-5800-034-3456	OTHER RESTRICTE,PROF/C	CR		6,870.00

Selection Grouped by Org, Fiscal Year, JE# - Sorted by JE Item #, (Org = 14, JE Type = R, Starting Post Date = 6/1/2022, Ending Post Date = 7/31/2022, Unposted JEs? = N, End Bud Bal? = O, JE# Page Break? = N, Description? = A, Recap? = N)

ESCAPE ONLINE

Effective 04/14/2022 through 07/29/2022

Fiscal Year 2022

Account	Description	Comment	From	To
			6,870.00	6,870.00
JE # BR22-01570 JE Trans Date 06/01/2022 JE Posted 06/01/2022 Comment GOLF TEAM EXPENSE				
(029646)	01-0808-0-1400-4100-5800-031-0807	Measure U,PROF/CONSULT :	DR	471.00
(022066)	01-0808-0-1400-4200-4300-031-0807	Measure U,MATERIALS & SU	DR	310.00
(032015)	01-0808-0-1400-4100-4300-031-0807	Measure U,MATERIALS & SU	CR	781.00
			781.00	781.00
JE # BR22-01571 JE Trans Date 05/12/2022 JE Posted 06/01/2022 Comment BL-YEA BUS INV22-01337 INTER.TXFR CT22-00581				
(007610)	01-9010-0-0000-0000-8699-530-0080	OTHER RESTRICTE,ALL OTI BL-YEA BUS INV22-01337	DR	286.00
				INTER.TXFR CT00581
(032017)	01-9010-0-1110-1000-5710-530-0080	OTHER RESTRICTE,XFER O BL-YEA BUS INV22-01337	CR	286.00
				INTER.TXFR CT00581
(003976)	01-0723-0-0000-3600-5710-048-0000	TRANSPORT:HOME,XFER O BL-YEA BUS INV22-01337	DR	286.00
				INTER.TXFR CT00581
(003941)	01-0723-0-0000-0000-8980-030-0000	TRANSPORT:HOME,CONTRI BL-YEA BUS INV22-01337	CR	286.00
				INTER.TXFR CT00581
(000054)	01-0000-0-0000-0000-8980-000-0000	NO REPORTING RE,CONTRI BL-YEA BUS INV22-01337	DR	286.00
				INTER.TXFR CT00581
			Net increase to Appropriations	572.00 858.00
JE # BR22-01572 JE Trans Date 06/01/2022 JE Posted 06/01/2022 Comment JL-For Replacement Supplies for B40SS				
(032018)	01-0000-0-3100-1000-4200-825-0004	NO REPORTING RE,BOOKS	CR	2,400.00
			Net increase to Appropriations	.00 2,400.00
JE # BR22-01573 JE Trans Date 06/01/2022 JE Posted 06/01/2022 Comment BL-SHS CTE BUS TO TWIN LAKES CHURCH T2275				
(015722)	01-0809-0-6000-1000-4300-835-0809	Measure T,MATERIALS & SU	DR	199.00
(027773)	01-0809-0-6000-1000-5710-835-0809	Measure T,XFER OF DIRECT	CR	199.00
(003976)	01-0723-0-0000-3600-5710-048-0000	TRANSPORT:HOME,XFER O	DR	199.00
(003941)	01-0723-0-0000-0000-8980-030-0000	TRANSPORT:HOME,CONTRI	CR	199.00
(000054)	01-0000-0-0000-0000-8980-000-0000	NO REPORTING RE,CONTRI	DR	199.00
			Net decrease to Appropriations	597.00 398.00
JE # BR22-01574 JE Trans Date 06/01/2022 JE Posted 06/01/2022 Comment BL-SCHS CTE BUS TR2276 TWIN LAKES 3/18/22				
(015721)	01-0809-0-6000-1000-4300-834-0809	Measure T,MATERIALS & SU	DR	199.00

Selection Grouped by Org, Fiscal Year, JE# - Sorted by JE Item #, (Org = 14, JE Type = R, Starting Post Date = 6/1/2022, Ending Post Date = 7/31/2022, Unposted JEs? = N, End Bud Bal? = O, JE# Page Break? = N, Description? = A, Recap? = N)

ESCAPE ONLINE

Effective 04/14/2022 through 07/29/2022

Fiscal Year 2022

Account	Description	Comment	From	To
(continued) JE # BR22-01574 JE Trans Date 06/01/2022 JE Posted 06/01/2022		Comment BL-SCHS CTE BUS TR2276 TWIN LAKES 3/18/22		
(032019) 01-0809-0-6000-1000-5710-834-0809	Measure T,XFER OF DIRECT	CR		199.00
(003976) 01-0723-0-0000-3600-5710-048-0000	TRANSPORT:HOME,XFER O	DR	199.00	
(003941) 01-0723-0-0000-0000-8980-030-0000	TRANSPORT:HOME,CONTRI	CR	199.00	
(000054) 01-0000-0-0000-0000-8980-000-0000	NO REPORTING RE,CONTRI	DR		199.00
Net decrease to Appropriations			597.00	398.00
JE # BR22-01575 JE Trans Date 06/01/2022 JE Posted 06/01/2022		Comment BL-SCHS CHOIR TR2277 MONTE VISTA SCH 3/25		
(003976) 01-0723-0-0000-3600-5710-048-0000	TRANSPORT:HOME,XFER O	DR	403.00	
(003941) 01-0723-0-0000-0000-8980-030-0000	TRANSPORT:HOME,CONTRI	CR	403.00	
(000054) 01-0000-0-0000-0000-8980-000-0000	NO REPORTING RE,CONTRI	DR		403.00
Net decrease to Appropriations			806.00	403.00
JE # BR22-01576 JE Trans Date 06/01/2022 JE Posted 06/01/2022		Comment BL-SCHS CHOIR 4/21/22 TR2278 CABRILLO		
(023495) 01-0809-0-1270-4100-5800-834-0809	Measure T,PROF/CONSULT	DR	2.00	
(030848) 01-0809-0-1270-4100-5710-834-0809	Measure T,XFER OF DIRECT	CR		2.00
(003976) 01-0723-0-0000-3600-5710-048-0000	TRANSPORT:HOME,XFER O	DR	199.00	
(003941) 01-0723-0-0000-0000-8980-030-0000	TRANSPORT:HOME,CONTRI	CR	199.00	
(000054) 01-0000-0-0000-0000-8980-000-0000	NO REPORTING RE,CONTRI	DR		199.00
Net decrease to Appropriations			400.00	201.00
JE # BR22-01577 JE Trans Date 06/02/2022 JE Posted 06/02/2022		Comment COVER OVERAGE ON PO		
(015718) 01-0809-0-6000-1000-4300-830-0809	Measure T,MATERIALS & SU	DR	20.00	
(016061) 01-0809-0-6000-1000-5600-835-0809	Measure T,RENTAL/LEASE/R	CR		20.00
Net decrease to Appropriations			20.00	20.00
JE # BR22-01578 JE Trans Date 06/02/2022 JE Posted 06/02/2022		Comment BD-IB EWRS		
(024382) 01-3010-0-1110-1000-1130-533-0000	BAS GNT LOW-INC,CERT SA	CR		360.00
(031570) 01-3010-0-1110-1000-1160-533-0000	BAS GNT LOW-INC,CERT SA	CR		1,500.00
(024373) 01-3010-0-1110-1000-3101-533-0000	BAS GNT LOW-INC,STRS:CE	CR		315.00
(024378) 01-3010-0-1110-1000-3331-533-0000	BAS GNT LOW-INC,MEDICAF	CR		27.00
(024380) 01-3010-0-1110-1000-3501-533-0000	BAS GNT LOW-INC,STATE U	CR		10.00
(024381) 01-3010-0-1110-1000-3601-533-0000	BAS GNT LOW-INC,WORKEF	CR		36.00
(024390) 01-3010-0-1110-1000-4300-533-0000	BAS GNT LOW-INC,MATERI/	DR	2,248.00	

Selection Grouped by Org, Fiscal Year, JE# - Sorted by JE Item #, (Org = 14, JE Type = R, Starting Post Date = 6/1/2022, Ending Post Date = 7/31/2022, Unposted JEs? = N, End Bud Bal? = O, JE# Page Break? = N, Description? = A, Recap? = N)

ESCAPE ONLINE

Page 3 of 88

Effective 04/14/2022 through 07/29/2022

Fiscal Year 2022

Account	Description	Comment	From	To
			2,248.00	2,248.00
JE # BR22-01579 JE Trans Date 06/02/2022 JE Posted 06/02/2022 Comment BL-PBIS PLAN MTG EWRS43591-5, EWR43598-99,43602-				
(027411)	01-7422-0-1110-1000-1130-823-0000	IPI GF,CERT SALARY:EWA,II	CR	4,752.00
(024642)	01-7422-0-1110-1000-3101-823-0000	IPI GF,STRS:CERT,INSTRUC	CR	805.00
(024647)	01-7422-0-1110-1000-3331-823-0000	IPI GF,MEDICARE:CERT,INS	CR	69.00
(024649)	01-7422-0-1110-1000-3501-823-0000	IPI GF,STATE UNEMPLOYM,	CR	24.00
(024650)	01-7422-0-1110-1000-3601-823-0000	IPI GF,WORKERS' COMP:C,I	CR	92.00
(029331)	01-7422-0-1110-1000-4300-823-0000	IPI GF,MATERIALS & SUP,IN	DR	5,742.00
			5,742.00	5,742.00
JE # BR22-01580 JE Trans Date 06/02/2022 JE Posted 06/02/2022 Comment BL-BV EWR 43898 VAN KIRK, ELIZ ASSIST AFTER SCH				
(027745)	01-6010-0-1110-1000-2130-521-0000	AFTER-SCHOOL ED,CLASS	CR	1,181.00
(024060)	01-6010-0-1110-1000-3312-521-0000	AFTER-SCHOOL ED,FICA:CL	CR	74.00
(024061)	01-6010-0-1110-1000-3332-521-0000	AFTER-SCHOOL ED,MEDICA	CR	18.00
(024063)	01-6010-0-1110-1000-3502-521-0000	AFTER-SCHOOL ED,STATE I	CR	6.00
(024064)	01-6010-0-1110-1000-3602-521-0000	AFTER-SCHOOL ED,WORKE	CR	23.00
(024065)	01-6010-0-1110-1000-4300-521-0000	AFTER-SCHOOL ED,MATERI	DR	1,302.00
			1,302.00	1,302.00
JE # BR22-01581 JE Trans Date 06/02/2022 JE Posted 06/02/2022 Comment BL-EWR 43815 MERI ANCIC, 5/16-6/15/22				
(031757)	01-0808-0-0000-2420-2230-832-0808	Measure U,CLASS PUPIL SUI	CR	180.00
(015392)	01-0808-0-0000-2420-3312-832-0808	Measure U,FICA:CLASS,INST	CR	12.00
(015393)	01-0808-0-0000-2420-3332-832-0808	Measure U,MEDICARE:CLAS	CR	3.00
(015395)	01-0808-0-0000-2420-3502-832-0808	Measure U,STATE UNEMPLC	CR	1.00
(015396)	01-0808-0-0000-2420-3602-832-0808	Measure U,WORKERS' COMF	CR	4.00
(020437)	01-0808-0-1110-1000-4300-832-0808	Measure U,MATERIALS & SU	DR	200.00
			200.00	200.00
JE # BR22-01582 JE Trans Date 06/02/2022 JE Posted 06/02/2022 Comment BL-EWR44035-44060 4/30-5/13 CURR MAP/GRADG TASK				
(030962)	01-3010-0-1110-1000-1130-531-0000	BAS GNT LOW-INC,CERT SA	CR	2,592.00
(024311)	01-3010-0-1110-1000-3101-531-0000	BAS GNT LOW-INC,STRS:CE	CR	439.00

Effective 04/14/2022 through 07/29/2022

Fiscal Year 2022

Account	Description	Comment	From	To
(continued) JE # BR22-01582 JE Trans Date 06/02/2022 JE Posted 06/02/2022 Comment BL-EWR44035-44060 4/30-5/13 CURR MAP/GRADG TASK				
(024316) 01- 3010- 0- 1110- 1000- 3331- 531- 0000	BAS GNT LOW-INC,MEDICAL	BL-EWR44035-44060 CURR	CR	38.00
		MAP/GRADING TASK FORCE		
(024318) 01- 3010- 0- 1110- 1000- 3501- 531- 0000	BAS GNT LOW-INC,STATE U	BL-EWR44035-44060 CURR	CR	13.00
		MAP/GRADING TASK FORCE		
(024319) 01- 3010- 0- 1110- 1000- 3601- 531- 0000	BAS GNT LOW-INC,WORKE	BL-EWR44035-44060 CURR	CR	50.00
		MAP/GRADING TASK FORCE		
(024321) 01- 3010- 0- 1110- 1000- 4300- 531- 0000	BAS GNT LOW-INC,MATERI	BL-EWR44035-44060 CURR	DR	3,132.00
		MAP/GRADING TASK FORCE		
			3,132.00	3,132.00

JE # BR22-01583 JE Trans Date 06/02/2022 JE Posted 06/02/2022 Comment SIGNAGE				
(031696) 01- 0000- 0- 0000- 8500- 5800- 033- 0000	NO REPORTING RE,PROF/C		CR	1,262.00
(031244) 01- 0000- 0- 1110- 2420- 5800- 033- 0000	NO REPORTING RE,PROF/C		DR	50.00
(002139) 01- 0000- 0- 1110- 2420- 4200- 033- 0000	NO REPORTING RE,BOOKS		DR	500.00
(001988) 01- 0000- 0- 1110- 1000- 5800- 033- 0000	NO REPORTING RE,PROF/C		DR	597.00
(001918) 01- 0000- 0- 1110- 1000- 4100- 033- 0000	NO REPORTING RE,APPR TI		DR	83.00
(001934) 01- 0000- 0- 1110- 1000- 4300- 033- 0000	NO REPORTING RE,MATERI		DR	32.00
			1,262.00	1,262.00

JE # BR22-01584 JE Trans Date 05/12/2022 JE Posted 06/02/2022 Comment BL-SCHS BAND TR2279 DEL MAR HS 4/30/22				
(003976) 01- 0723- 0- 0000- 3600- 5710- 048- 0000	TRANSPORT:HOME,XFER O		DR	920.00
(003941) 01- 0723- 0- 0000- 0000- 8980- 030- 0000	TRANSPORT:HOME,CONTRI		CR	920.00
(000054) 01- 0000- 0- 0000- 0000- 8980- 000- 0000	NO REPORTING RE,CONTRI		DR	920.00
			1,840.00	920.00

JE # BR22-01585 JE Trans Date 06/02/2022 JE Posted 06/02/2022 Comment BL-SCHS CHOIR TR2280 TO SCCOE 5/2/22				
(009086) 01- 9016- 0- 1270- 1000- 4300- 034- 3410	DONATIONS,MATERIALS & S		DR	80.00
(032031) 01- 9016- 0- 1270- 1000- 5710- 034- 3410	DONATIONS,XFER OF DIRE		CR	80.00
(003976) 01- 0723- 0- 0000- 3600- 5710- 048- 0000	TRANSPORT:HOME,XFER O		DR	80.00
(003941) 01- 0723- 0- 0000- 0000- 8980- 030- 0000	TRANSPORT:HOME,CONTRI		CR	80.00
(000054) 01- 0000- 0- 0000- 0000- 8980- 000- 0000	NO REPORTING RE,CONTRI		DR	80.00
			240.00	160.00

JE # BR22-01586 JE Trans Date 06/02/2022 JE Posted 06/02/2022 Comment BL-GAEL TR2281 BUS MONTEREY AQUARIUM 3/29/22

Selection Grouped by Org, Fiscal Year, JE# - Sorted by JE Item #, (Org = 14, JE Type = R, Starting Post Date = 6/1/2022, Ending Post Date = 7/31/2022, Unposted JEs? = N, End Bud Bal? = O, JE# Page Break? = N, Description? = A, Recap? = N)

ESCAPE ONLINE

Page 5 of 88

Effective 04/14/2022 through 07/29/2022

Fiscal Year 2022

Account	Description	Comment	From	To
(continued) JE # BR22-01586 JE Trans Date 06/02/2022 JE Posted 06/02/2022		Comment BL-GAEL TR2281 BUS MONTEREY AQUARIUM 3/29/22		
(024285) 01-3010-0-1110-1000-4300-524-0000	BAS GNT LOW-INC,MATERI/	DR	463.00	
(029812) 01-3010-0-1110-1000-5710-524-0000	BAS GNT LOW-INC,XFER OF	CR		463.00
(003976) 01-0723-0-0000-3600-5710-048-0000	TRANSPORT:HOME,XFER O	DR	463.00	
(003941) 01-0723-0-0000-0000-8980-030-0000	TRANSPORT:HOME,CONTRI	CR	463.00	
(000054) 01-0000-0-0000-0000-8980-000-0000	NO REPORTING RE,CONTRI	DR		463.00
Net decrease to Appropriations			1,389.00	926.00

JE # BR22-01587 JE Trans Date 06/02/2022 JE Posted 06/02/2022		Comment BL-GAULT TR2282 WILDER RANCH 4/29/22		
(008752) 01-9016-0-1110-1000-4300-024-0051	DONATIONS,MATERIALS & €	DR	171.00	
(008798) 01-9016-0-1110-1000-5710-024-0051	DONATIONS,XFER OF DIRE(CR		171.00
(003976) 01-0723-0-0000-3600-5710-048-0000	TRANSPORT:HOME,XFER O	DR	171.00	
(003941) 01-0723-0-0000-0000-8980-030-0000	TRANSPORT:HOME,CONTRI	CR	171.00	
(000054) 01-0000-0-0000-0000-8980-000-0000	NO REPORTING RE,CONTRI	DR		171.00
Net decrease to Appropriations			513.00	342.00

JE # BR22-01588 JE Trans Date 06/03/2022 JE Posted 06/03/2022		Comment BL-BMS TR2283 HARVEY W. 4/1 J.HEDGECOCK 3 BUSE		
(008808) 01-9016-0-1110-1000-5800-031-3156	DONATIONS,PROF/CONSUL	DR	564.00	
(008800) 01-9016-0-1110-1000-5710-031-3156	DONATIONS,XFER OF DIRE(CR		564.00
(003976) 01-0723-0-0000-3600-5710-048-0000	TRANSPORT:HOME,XFER O	DR	564.00	
(003941) 01-0723-0-0000-0000-8980-030-0000	TRANSPORT:HOME,CONTRI	CR	564.00	
(000054) 01-0000-0-0000-0000-8980-000-0000	NO REPORTING RE,CONTRI	DR		564.00
Net decrease to Appropriations			1,692.00	1,128.00

JE # BR22-01589 JE Trans Date 06/03/2022 JE Posted 06/03/2022		Comment BL-BMS TR2284 C.O'BRIEN-HARVEY WEST 5/25/22		
(008808) 01-9016-0-1110-1000-5800-031-3156	DONATIONS,PROF/CONSUL	DR	230.00	
(008800) 01-9016-0-1110-1000-5710-031-3156	DONATIONS,XFER OF DIRE(CR		230.00
(003976) 01-0723-0-0000-3600-5710-048-0000	TRANSPORT:HOME,XFER O	DR	230.00	
(003941) 01-0723-0-0000-0000-8980-030-0000	TRANSPORT:HOME,CONTRI	CR	230.00	
(000054) 01-0000-0-0000-0000-8980-000-0000	NO REPORTING RE,CONTRI	DR		230.00
Net decrease to Appropriations			690.00	460.00

JE # BR22-01590 JE Trans Date 06/03/2022 JE Posted 06/03/2022		Comment BL-MH TR2285 SPED TO MONTEREY SANCTUARY 4/22		
(003976) 01-0723-0-0000-3600-5710-048-0000	TRANSPORT:HOME,XFER O	DR	120.00	
(003941) 01-0723-0-0000-0000-8980-030-0000	TRANSPORT:HOME,CONTRI	CR	120.00	

Selection Grouped by Org, Fiscal Year, JE# - Sorted by JE Item #, (Org = 14, JE Type = R, Starting Post Date = 6/1/2022, Ending Post Date = 7/31/2022, Unposted JEs? = N, End Bud Bal? = O, JE# Page Break? = N, Description? = A, Recap? = N)

ESCAPE ONLINE

Effective 04/14/2022 through 07/29/2022

Fiscal Year 2022

Account	Description	Comment	From	To
(continued) JE # BR22-01590 JE Trans Date 06/03/2022 JE Posted 06/03/2022	Comment BL-MH TR2285 SPED TO MONTEREY SANCTUARY 4/22			
(000054) 01-0000-0-0000-0000-8980-000-0000	NO REPORTING RE,CONTRI	DR		120.00
Net decrease to Appropriations			240.00	120.00
JE # BR22-01591 JE Trans Date 06/03/2022 JE Posted 06/03/2022	Comment MH-CHOIR TO BV/WL 5/4/22 TR2286			
(003976) 01-0723-0-0000-3600-5710-048-0000	TRANSPORT:HOME,XFER O	DR	146.00	
(003941) 01-0723-0-0000-0000-8980-030-0000	TRANSPORT:HOME,CONTRI	CR	146.00	
(000054) 01-0000-0-0000-0000-8980-000-0000	NO REPORTING RE,CONTRI	DR		146.00
Net decrease to Appropriations			292.00	146.00
JE # BR22-01592 JE Trans Date 05/31/2022 JE Posted 06/03/2022	Comment BL-SPROUTS MAY INV22-01332 CK1055			
(027199) 01-9010-0-0000-0000-8650-058-0553	OTHER RESTRICTE,LEASES	DR		1,550.00
(028353) 01-9010-0-0000-7300-4300-058-0553	OTHER RESTRICTE,MATERI	CR		1,550.00
Net increase to Appropriations			.00	3,100.00
JE # BR22-01593 JE Trans Date 06/03/2022 JE Posted 06/03/2022	Comment PO22-00354			
(023492) 21-9733-0-0000-8500-6280-034-B166	BOND A SECONDAR,CONST	CR		3,318.00
(009895) 21-9733-0-0000-8500-6200-000-0000	BOND A SECONDAR,BUILDII	CR		3,318.00
Net increase to Appropriations			.00	6,636.00
JE # BR22-01594 JE Trans Date 06/03/2022 JE Posted 06/03/2022	Comment R22-02609			
(032032) 21-9734-0-0000-8500-6202-021-B006	Bond A Elem,MODERNIZATIC	CR		38,800.00
(010424) 21-9734-0-0000-8500-6200-000-0000	BOND A ELEM,BUILDINGS &	CR		38,800.00
Net increase to Appropriations			.00	77,600.00
JE # BR22-01595 JE Trans Date 06/03/2022 JE Posted 06/03/2022	Comment R22-02610			
(032032) 21-9734-0-0000-8500-6202-021-B006	Bond A Elem,MODERNIZATIC	CR		147,899.00
(010424) 21-9734-0-0000-8500-6200-000-0000	BOND A ELEM,BUILDINGS &	CR		147,899.00
Net increase to Appropriations			.00	295,798.00
JE # BR22-01596 JE Trans Date 06/03/2022 JE Posted 06/03/2022	Comment R22-02615			
(014935) 21-9733-0-0000-8500-6400-031-B417	BOND A SECONDAR,EQUIPI	CR		70,145.00
(009895) 21-9733-0-0000-8500-6200-000-0000	BOND A SECONDAR,BUILDII	CR		70,145.00

Selection Grouped by Org, Fiscal Year, JE# - Sorted by JE Item #, (Org = 14, JE Type = R, Starting Post Date = 6/1/2022, Ending Post Date = 7/31/2022, Unposted JEs? = N, End Bud Bal? = O, JE# Page Break? = N, Description? = A, Recap? = N)

ESCAPE ONLINE

Effective 04/14/2022 through 07/29/2022

Fiscal Year 2022

Account	Description	Comment	From	To
Net increase to Appropriations			.00	140,290.00
JE # BR22-01597 JE Trans Date 06/03/2022 JE Posted 06/03/2022 Comment R22-02611				
(032033) 21-9733-0-0000-8500-6203-033-B407	Bond A Secondar,BUILDING		CR	311,533.00
(009895) 21-9733-0-0000-8500-6200-000-0000	BOND A SECONDAR,BUILDII		CR	311,533.00
Net increase to Appropriations			.00	623,066.00
JE # BR22-01598 JE Trans Date 06/03/2022 JE Posted 06/03/2022 Comment R22-02612				
(032034) 21-9734-0-0000-8500-6202-024-B010	Bond A Elem,MODERNIZATIC		CR	10,833.00
(010424) 21-9734-0-0000-8500-6200-000-0000	BOND A ELEM,BUILDINGS &		CR	10,833.00
Net increase to Appropriations			.00	21,666.00
JE # BR22-01599 JE Trans Date 06/03/2022 JE Posted 06/03/2022 Comment PO22-00236				
(013762) 21-9734-0-0000-8500-6202-027-B161	BOND A ELEM,MODERNIZA1		CR	9,796.00
(010424) 21-9734-0-0000-8500-6200-000-0000	BOND A ELEM,BUILDINGS &		CR	9,796.00
Net increase to Appropriations			.00	19,592.00
JE # BR22-01600 JE Trans Date 06/03/2022 JE Posted 06/03/2022 Comment R22-02613				
(032035) 21-9734-0-0000-8500-6280-024-B129	Bond A Elem,CONSTRUCTIO		CR	6,750.00
(010424) 21-9734-0-0000-8500-6200-000-0000	BOND A ELEM,BUILDINGS &		CR	6,750.00
Net increase to Appropriations			.00	13,500.00
JE # BR22-01601 JE Trans Date 06/03/2022 JE Posted 06/03/2022 Comment R22-02614				
(027692) 21-9734-0-0000-8500-5800-021-B004	BOND A ELEM,PROF/CONSL		CR	6,396.00
(010424) 21-9734-0-0000-8500-6200-000-0000	BOND A ELEM,BUILDINGS &		CR	6,396.00
Net increase to Appropriations			.00	12,792.00
JE # BR22-01602 JE Trans Date 05/31/2022 JE Posted 06/03/2022 Comment BL-SPROUTS MAY INV22-01332 CK1055				
(027199) 01-9010-0-0000-0000-8650-058-0553	OTHER RESTRICTE,LEASES		CR	1,550.00
(028353) 01-9010-0-0000-7300-4300-058-0553	OTHER RESTRICTE,MATERI		DR	1,550.00
Net decrease to Appropriations			3,100.00	.00
JE # BR22-01603 JE Trans Date 06/03/2022 JE Posted 06/03/2022 Comment BL-DU88028 SPROUTS MAY CK1055				

Selection Grouped by Org, Fiscal Year, JE# - Sorted by JE Item #, (Org = 14, JE Type = R, Starting Post Date = 6/1/2022, Ending Post Date = 7/31/2022, Unposted JEs? = N, End Bud Bal? = O, JE# Page Break? = N, Description? = A, Recap? = N)

ESCAPE ONLINE

Effective 04/14/2022 through 07/29/2022

Fiscal Year 2022

Account	Description	Comment	From	To
(continued) JE # BR22-01603 JE Trans Date 06/03/2022 JE Posted 06/03/2022 Comment BL-DU88028 SPROUTS MAY CK1055				
(027199) 01-9010-0-0000-0000-8650-058-0553	OTHER RESTRICTE,LEASES	BL-DU88028 SPROUTS MAY CK1055	DR	1,500.00
		\$1500 APPLIED		
(028353) 01-9010-0-0000-7300-4300-058-0553	OTHER RESTRICTE,MATERI	BL-DU88028 SPROUTS MAY CK1055	CR	1,500.00
		\$1500 APPLIED		
Net increase to Appropriations			.00	3,000.00

Account	Description	Comment	From	To
JE # BR22-01604 JE Trans Date 06/06/2022 JE Posted 06/06/2022 Comment JL-For Lease Building Removals at DLV				
(020511) 25-9010-0-0000-8700-5600-023-9121	OTHER RESTRICTE,RENTAL		CR	25,357.00
Net increase to Appropriations			.00	25,357.00

Account	Description	Comment	From	To
JE # BR22-01605 JE Trans Date 06/06/2022 JE Posted 06/06/2022 Comment JL-for Replacement Books for Monarch				
(032018) 01-0000-0-3100-1000-4200-825-0004	NO REPORTING RE,BOOKS		CR	2,600.00
(002736) 01-0000-0-3100-1000-1100-825-0000	NO REPORTING RE,CERT:TI		DR	1,257.00
(002759) 01-0000-0-3100-1000-3601-825-0000	NO REPORTING RE,WORKE		DR	984.00
(002749) 01-0000-0-3100-1000-3331-825-0000	NO REPORTING RE,MEDICA		DR	359.00
Net increase to Appropriations			2,600.00	2,600.00

Account	Description	Comment	From	To
JE # BR22-01606 JE Trans Date 06/06/2022 JE Posted 06/06/2022 Comment BL-EWR 42308/43915 5254 HORN, 5303 PONKEY 6/1-30				
(031100) 01-3010-0-1115-1000-1130-505-0000	BAS GNT LOW-INC,CERT SA	BL-5254 HORN, MORGAN 6/1-30/22	CR	4,680.00
		EWR42308		
(031100) 01-3010-0-1115-1000-1130-505-0000	BAS GNT LOW-INC,CERT SA	BL-5303 PONKEY,JAINA 6/1-30 EWR	CR	4,680.00
		43915		
(031101) 01-3010-0-1115-1000-3101-505-0000	BAS GNT LOW-INC,STRS:CE	BL-EWR 42308/43915 HORN/PONKEY	CR	1,584.00
(031106) 01-3010-0-1115-1000-3331-505-0000	BAS GNT LOW-INC,MEDICAF	BL-EWR 42308/43915 HORN/PONKEY	CR	136.00
(031108) 01-3010-0-1115-1000-3501-505-0000	BAS GNT LOW-INC,STATE U	BL-EWR 42308/43915 HORN/PONKEY	CR	47.00
(031109) 01-3010-0-1115-1000-3601-505-0000	BAS GNT LOW-INC,WORKEF	BL-EWR 42308/43915 HORN/PONKEY	CR	180.00
(027608) 01-3010-0-1110-1000-4399-520-0000	BAS GNT LOW-INC,HOLDINC	BL-EWR 42308/43915 HORN/PONKEY	DR	11,307.00
Net increase to Appropriations			11,307.00	11,307.00

Account	Description	Comment	From	To
JE # BR22-01607 JE Trans Date 05/31/2022 JE Posted 06/06/2022 Comment BL-480 SMITH, JAMES 5/13-15/22 MATH ENRICH EWR434				
(017775) 01-9016-0-1160-1000-1160-027-0051	DONATIONS,CERT SALARY:		CR	1,200.00
(017776) 01-9016-0-1160-1000-3101-027-0051	DONATIONS,STRS:CERT,IN		CR	204.00
(017781) 01-9016-0-1160-1000-3331-027-0051	DONATIONS,MEDICARE:CEF		CR	18.00
(017783) 01-9016-0-1160-1000-3501-027-0051	DONATIONS,STATE UNEMP		CR	6.00

Selection Grouped by Org, Fiscal Year, JE# - Sorted by JE Item #, (Org = 14, JE Type = R, Starting Post Date = 6/1/2022, Ending Post Date = 7/31/2022, Unposted JEs? = N, End Bud Bal? = O, JE# Page Break? = N, Description? = A, Recap? = N)

ESCAPE ONLINE

Page 9 of 88

Effective 04/14/2022 through 07/29/2022

Fiscal Year 2022

Account	Description	Comment	From	To
(continued) JE # BR22-01607 JE Trans Date 05/31/2022 JE Posted 06/06/2022		Comment BL-480 SMITH, JAMES 5/13-15/22 MATH ENRICH EWR434		
(017784) 01-9016-0-1160-1000-3601-027-0051	DONATIONS,WORKERS' CO	CR		23.00
(008755) 01-9016-0-1110-1000-4300-027-0051	DONATIONS,MATERIALS & S	DR	1,451.00	
			1,451.00	1,451.00

JE # BR22-01608 JE Trans Date 06/06/2022 JE Posted 06/06/2022	Comment BL-4855 BERNARDI, T 5/16-6/15/22 SUMMER OFC ASST E			
(031740) 01-9016-0-0000-2700-2430-027-0051	DONATIONS,CLASS CLERIC	CR		717.00
(031744) 01-9016-0-0000-2700-3202-027-0051	DONATIONS,PERS:CLASSIF	CR		165.00
(031745) 01-9016-0-0000-2700-3312-027-0051	DONATIONS,FICA:CLASS,SC	CR		45.00
(031746) 01-9016-0-0000-2700-3332-027-0051	DONATIONS,MEDICARE:CLA	CR		11.00
(031748) 01-9016-0-0000-2700-3502-027-0051	DONATIONS,STATE UNEMP	CR		4.00
(031749) 01-9016-0-0000-2700-3602-027-0051	DONATIONS,WORKERS' CO	CR		14.00
(008755) 01-9016-0-1110-1000-4300-027-0051	DONATIONS,MATERIALS & S	DR	956.00	
			956.00	956.00

JE # BR22-01609 JE Trans Date 05/31/2022 JE Posted 06/06/2022	Comment BL-4405 RODECKER, CATHERINE 2/16-6/30/22 ASSMT EW			
(030707) 01-6537-0-5760-3120-1230-232-0000	Sped Learn Rec,CERT PUPIL	BL-4405 RODECKER, CATHERINE 2/16-6/30/22 PSYCH ASSESMT.	CR	720.00
(030708) 01-6537-0-5760-3120-3101-232-0000	Sped Learn Rec,STRS:CERT,	BL-4405 RODECKER, CATHERINE 2/16-6/30/22 PSYCH ASSESMT.	CR	122.00
(030713) 01-6537-0-5760-3120-3331-232-0000	Sped Learn Rec,MEDICARE:C	BL-4405 RODECKER, CATHERINE 2/16-6/30/22 PSYCH ASSESMT.	CR	11.00
(030715) 01-6537-0-5760-3120-3501-232-0000	Sped Learn Rec,STATE UNEM	BL-4405 RODECKER, CATHERINE 2/16-6/30/22 PSYCH ASSESMT.	CR	4.00
(030716) 01-6537-0-5760-3120-3601-232-0000	Sped Learn Rec,WORKERS' C	BL-4405 RODECKER, CATHERINE 2/16-6/30/22 PSYCH ASSESMT.	CR	14.00
(028175) 01-6537-0-5760-1110-4300-230-0000	Sped Learn Rec,MATERIALS	BL-4405 RODECKER, C 2/16-6/30/22 PSYCH ASSESMT.	DR	871.00
			871.00	871.00

JE # BR22-01610 JE Trans Date 05/31/2022 JE Posted 06/06/2022	Comment BL-163 SCHIPPER, H 2/16-6/30/22 EWR41536 ASSESMTS			
(029516) 01-6537-0-5760-1120-1130-220-0000	Sped Learn Rec,CERT SALAF		CR	720.00
(029517) 01-6537-0-5760-1120-3101-220-0000	Sped Learn Rec,STRS:CERT,		CR	122.00
(029522) 01-6537-0-5760-1120-3331-220-0000	Sped Learn Rec,MEDICARE:C		CR	11.00
(029524) 01-6537-0-5760-1120-3501-220-0000	Sped Learn Rec,STATE UNEM		CR	4.00
(029525) 01-6537-0-5760-1120-3601-220-0000	Sped Learn Rec,WORKERS' C		CR	14.00

Selection Grouped by Org, Fiscal Year, JE# - Sorted by JE Item #, (Org = 14, JE Type = R, Starting Post Date = 6/1/2022, Ending Post Date = 7/31/2022, Unposted JEs? = N, End Bud Bal? = O, JE# Page Break? = N, Description? = A, Recap? = N)

ESCAPE ONLINE

Page 10 of 88

Effective 04/14/2022 through 07/29/2022

Fiscal Year 2022

Account	Description	Comment	From	To
(continued) JE # BR22-01610 JE Trans Date 05/31/2022 JE Posted 06/06/2022	Comment BL-163 SCHIPPER, H 2/16-6/30/22 EWR41536 ASSESMTS			
(028174) 01- 6537- 0- 5760- 1110- 4300- 220- 0000	Sped Learn Rec,MATERIALS		DR 871.00	
			871.00	871.00
JE # BR22-01611 JE Trans Date 04/30/2022 JE Posted 06/06/2022	Comment BL-5145 CORTEZ, ESTEVAN 4/16-6/15/22 EWR41658			
(024087) 01- 6010- 0- 1110- 1000- 2130- 524- 0000	AFTER-SCHOOL ED,CLASS		CR 1,490.00	
(024082) 01- 6010- 0- 1110- 1000- 3312- 524- 0000	AFTER-SCHOOL ED,FICA:CL		CR 93.00	
(024083) 01- 6010- 0- 1110- 1000- 3332- 524- 0000	AFTER-SCHOOL ED,MEDICA		CR 22.00	
(024085) 01- 6010- 0- 1110- 1000- 3502- 524- 0000	AFTER-SCHOOL ED,STATE I		CR 8.00	
(024086) 01- 6010- 0- 1110- 1000- 3602- 524- 0000	AFTER-SCHOOL ED,WORKE		CR 29.00	
(024088) 01- 6010- 0- 1110- 1000- 4300- 524- 0000	AFTER-SCHOOL ED,MATERI		DR 1,642.00	
			1,642.00	1,642.00
JE # BR22-01612 JE Trans Date 06/06/2022 JE Posted 06/06/2022	Comment JL-For Surface Pro for Jim/Finance			
(028541) 01- 0000- 0- 0000- 7600- 4400- 058- 0000	NO REPORTING RE,NON-CA		CR 2,346.00	
(023979) 01- 0000- 0- 0000- 7600- 3312- 858- 0000	NO REPORTING RE,FICA:CL		DR 2,346.00	
			2,346.00	2,346.00
JE # BR22-01613 JE Trans Date 06/06/2022 JE Posted 06/06/2022	Comment JL-For Hearing Tips			
(029359) 01- 6500- 0- 5760- 1190- 4300- 200- 0000	SE:STATE LOCAL,MATERIAL		CR 100.00	
(006987) 01- 6500- 0- 5760- 1190- 5200- 220- 0000	SE:STATE LOCAL ,TRAVEL &		DR 100.00	
			100.00	100.00
JE # BR22-01614 JE Trans Date 06/06/2022 JE Posted 06/06/2022	Comment SCHOLASTIC SUBSCRIPTIONS			
(008743) 01- 9016- 0- 1110- 1000- 4300- 021- 2110	DONATIONS,MATERIALS & S		DR 159.00	
(008805) 01- 9016- 0- 1110- 1000- 5800- 021- 2110	DONATIONS,PROF/CONSUL		CR 159.00	
			159.00	159.00
JE # BR22-01615 JE Trans Date 06/06/2022 JE Posted 06/06/2022	Comment BL-DLV EWRS			
(003372) 01- 0700- 0- 1110- 1000- 1130- 023- 0000	LCFF SUPP FUNDI,CERT SA BL-EWR 2087 JOHNSON, M 1/27-6/15		CR 576.00	
(003372) 01- 0700- 0- 1110- 1000- 1130- 023- 0000	LCFF SUPP FUNDI,CERT SA BL-EWR 949 CARDENAS, A 2/16-6/15		CR 288.00	
(003372) 01- 0700- 0- 1110- 1000- 1130- 023- 0000	LCFF SUPP FUNDI,CERT SA BL-EWR786 CENTANNI, B 2/16-6/15		CR 288.00	
(003372) 01- 0700- 0- 1110- 1000- 1130- 023- 0000	LCFF SUPP FUNDI,CERT SA BL-EWR652 BUTLER, H 2/16-6/15		CR 288.00	
(003372) 01- 0700- 0- 1110- 1000- 1130- 023- 0000	LCFF SUPP FUNDI,CERT SA BL-EWR 4843 OLIVA, H 2/16-6/15		CR 288.00	
Selection Grouped by Org, Fiscal Year, JE# - Sorted by JE Item #, (Org = 14, JE Type = R, Starting Post Date = 6/1/2022, Ending Post Date = 7/31/2022, Unposted JEs? = N, End Bud Bal? = O, JE# Page Break? = N, Description? = A, Recap? = N)				

ESCAPE ONLINE

Effective 04/14/2022 through 07/29/2022

Fiscal Year 2022

Account	Description	Comment	From	To
(continued) JE # BR22-01615 JE Trans Date 06/06/2022 JE Posted 06/06/2022 Comment BL-DLV EWRS				
(003372) 01-0700-0-1110-1000-1130-023-0000	LCFF SUPP FUNDI,CERT SA BL-EWR 2087 JOHNSON, M 2/16-6/15	CR		288.00
(003372) 01-0700-0-1110-1000-1130-023-0000	LCFF SUPP FUNDI,CERT SA BL-EWR1764 JIMENEZ, M 2/16-6/15	CR		288.00
(003372) 01-0700-0-1110-1000-1130-023-0000	LCFF SUPP FUNDI,CERT SA BL-EWR 4865 DAILLAK, K 2/16-6/15	CR		288.00
(003372) 01-0700-0-1110-1000-1130-023-0000	LCFF SUPP FUNDI,CERT SA BL-EWR 3335 MORALES-MCGIBBEN 2/16-6/15	CR		288.00
(003372) 01-0700-0-1110-1000-1130-023-0000	LCFF SUPP FUNDI,CERT SA BL-EWR 2923 PRICE, L 2/16-6/15/22	CR		288.00
(003445) 01-0700-0-1110-1000-3101-023-0000	LCFF SUPP FUNDI,STRS:CE BL-DLV EWRS X 10 STAT.BEN.	CR		537.00
(003509) 01-0700-0-1110-1000-3331-023-0000	LCFF SUPP FUNDI,MEDICAF BL-DLV EWRS X 10 STAT.BEN.	CR		46.00
(003558) 01-0700-0-1110-1000-3501-023-0000	LCFF SUPP FUNDI,STATE U BL-DLV EWRS X 10 STAT.BEN.	CR		16.00
(003593) 01-0700-0-1110-1000-3601-023-0000	LCFF SUPP FUNDI,WORKER BL-DLV EWRS X 10 STAT.BEN.	CR		61.00
(003639) 01-0700-0-1110-1000-4300-023-0000	LCFF SUPP FUNDI,MATERIA BL-DLV EWRS X 10 STAT.BEN.	DR	3,828.00	
			3,828.00	3,828.00
JE # BR22-01616 JE Trans Date 06/06/2022 JE Posted 06/06/2022 Comment BL-COVER NEGATIVES				
(003382) 01-0700-0-1110-1000-1140-023-0000	LCFF SUPP FUNDI,CERT SA BL-COVER NEGATIVES, B.DIAZ TITLE I EXP MOVED TO 3010	CR		3,300.00
(003478) 01-0700-0-1110-1000-3311-023-0000	LCFF SUPP FUNDI,FICA:CEF	CR		28.00
(003639) 01-0700-0-1110-1000-4300-023-0000	LCFF SUPP FUNDI,MATERIA	DR	3,328.00	
			3,328.00	3,328.00
JE # BR22-01617 JE Trans Date 06/06/2022 JE Posted 06/06/2022 Comment JL-For Speechrighter Invoices				
(029326) 01-6537-0-5760-1180-5800-230-0000	Sped Learn Rec,PROF/CONS	CR		1,035.00
(028175) 01-6537-0-5760-1110-4300-230-0000	Sped Learn Rec,MATERIALS	DR	1,035.00	
			1,035.00	1,035.00
JE # BR22-01618 JE Trans Date 06/06/2022 JE Posted 06/06/2022 Comment JL-for Scholastic magazine				
(029287) 01-6500-0-5760-1110-5800-235-0000	SE:STATE LOCAL,PROF/COI	DR	314.00	
(006657) 01-6500-0-5760-1110-4300-235-0000	SE:STATE LOCAL ,MATERIA	CR		314.00
			314.00	314.00
JE # BR22-01619 JE Trans Date 06/06/2022 JE Posted 06/06/2022 Comment BL-EWRS 853 MARIZETTE,G 9/8/21-6/30/22				
(027746) 01-0700-0-0000-2700-2430-021-0000	LCFF SUPP FUNDI,CLASS C BL-EWR 853 MARIZETTE,G 9/8/21-6/15/22	CR		21.00

Effective 04/14/2022 through 07/29/2022

Fiscal Year 2022

Account	Description	Comment	From	To
(continued) JE # BR22-01619 JE Trans Date 06/06/2022 JE Posted 06/06/2022 Comment BL-EWRS 853 MARIZETTE,G 9/8/21-6/30/22				
(027746) 01-0700-0-0000-2700-2430-021-0000	LCFF SUPP FUNDI,CLASS C	BL-EWR 853 MARIZETTE,G 12/16/21-6/15/22	CR	277.00
(027746) 01-0700-0-0000-2700-2430-021-0000	LCFF SUPP FUNDI,CLASS C	BL-EWR 853 MARIZETTE,G 4/27/22-6/30/22	CR	1,604.00
(027746) 01-0700-0-0000-2700-2430-021-0000	LCFF SUPP FUNDI,CLASS C	BL-EWR 853 MARIZETTE,G 6/1/22-6/30/22	CR	1,015.00
(027751) 01-0700-0-0000-2700-3312-021-0000	LCFF SUPP FUNDI,FICA:CLA		CR	181.00
(027752) 01-0700-0-0000-2700-3332-021-0000	LCFF SUPP FUNDI,MEDICAF		CR	43.00
(027754) 01-0700-0-0000-2700-3502-021-0000	LCFF SUPP FUNDI,STATE U		CR	15.00
(027755) 01-0700-0-0000-2700-3602-021-0000	LCFF SUPP FUNDI,WORKER		CR	56.00
(003638) 01-0700-0-1110-1000-4300-021-0000	LCFF SUPP FUNDI,MATERIA		DR 3,858.00	
(027750) 01-0700-0-0000-2700-3202-021-0000	LCFF SUPP FUNDI,PERS:CL		CR	646.00
			3,858.00	3,858.00

JE # BR22-01620 JE Trans Date 06/06/2022 JE Posted 06/06/2022 Comment BL-EWR 652 BUTLER, HOLLY 6/1-3/22 PBIS EWR43590				
(027411) 01-7422-0-1110-1000-1130-823-0000	IPI GF,CERT SALARY:EWA,II		CR	432.00
(024642) 01-7422-0-1110-1000-3101-823-0000	IPI GF,STRS:CERT,INSTRUC		CR	74.00
(024647) 01-7422-0-1110-1000-3331-823-0000	IPI GF,MEDICARE:CERT,INS		CR	7.00
(024649) 01-7422-0-1110-1000-3501-823-0000	IPI GF,STATE UNEMPLOYM,		CR	3.00
(024650) 01-7422-0-1110-1000-3601-823-0000	IPI GF,WORKERS' COMP:C,I		CR	9.00
(029331) 01-7422-0-1110-1000-4300-823-0000	IPI GF,MATERIALS & SUP,IN		DR 525.00	
			525.00	525.00

JE # BR22-01621 JE Trans Date 06/03/2022 JE Posted 06/06/2022 Comment BL-DU88028 SLVUSD BUS 3/28 AND 4/22/22				
(003956) 01-0723-0-0000-3600-2290-848-0000	TRANSPORT:HOME,CLASS I	BL-DU88028 SLVUSD BUS 3/28/22 INV22-01342	CR	285.00
(003940) 01-0723-0-0000-0000-8699-848-0000	TRANSPORT:HOME,ALL OTI	BL-DU88028 SLVUSD BUS 3/28/22 INV22-01342	DR	285.00
(003956) 01-0723-0-0000-3600-2290-848-0000	TRANSPORT:HOME,CLASS I	BL-DU88028 SLVUSD BUS 4/22/22 INV22-01343	CR	303.00
(003940) 01-0723-0-0000-0000-8699-848-0000	TRANSPORT:HOME,ALL OTI	BL-DU88028 SLVUSD BUS 4/22/22 INV22-01343	DR	303.00

Net increase to Appropriations .00 1,176.00

JE # BR22-01622 JE Trans Date 06/07/2022 JE Posted 06/07/2022 Comment BD-SUMMER SCHOOL FIELD TRIPS				
---	--	--	--	--

Selection Grouped by Org, Fiscal Year, JE# - Sorted by JE Item #, (Org = 14, JE Type = R, Starting Post Date = 6/1/2022, Ending Post Date = 7/31/2022, Unposted JEs? = N, End Bud Bal? = O, JE# Page Break? = N, Description? = A, Recap? = N)

ESCAPE ONLINE

Effective 04/14/2022 through 07/29/2022

Fiscal Year 2022

Account	Description	Comment	From	To
(continued) JE # BR22-01622 JE Trans Date 06/07/2022 JE Posted 06/07/2022	Comment BD-SUMMER SCHOOL FIELD TRIPS			
(032052) 01-3219-0-1115-1000-5710-505-0000	ELO ESSERIII LL,XFER OF D	CR		615.00
(030156) 01-3219-0-1115-1000-4399-505-0000	ELO ESSERIII LL,HOLDING A	DR	615.00	
			615.00	615.00
JE # BR22-01623 JE Trans Date 06/07/2022 JE Posted 06/07/2022	Comment JL-Add COOP Budget for Revenue for 2021-22			
(009523) 13-9010-0-0000-0000-8699-046-4606	OTHER RESTRICTE,ALL OTI	DR		3,750.00
(025915) 13-9010-0-0000-3700-5800-046-4606	OTHER RESTRICTE,PROF/C	CR		3,750.00
Net increase to Appropriations			.00	7,500.00
JE # BR22-01624 JE Trans Date 06/07/2022 JE Posted 06/07/2022	Comment JL-for Repairing Floor			
(007539) 01-8150-0-0000-8110-5600-049-0000	ONGOING & MAJOR,RENTAL	CR		3,600.00
(007542) 01-8150-0-0000-8110-6400-049-0000	ONGOING & MAJOR,EQUIPM	DR	3,600.00	
			3,600.00	3,600.00
JE # BR22-01625 JE Trans Date 06/07/2022 JE Posted 06/07/2022	Comment SPEECHRIGHTER INV 13437			
(028175) 01-6537-0-5760-1110-4300-230-0000	Sped Learn Rec,MATERIALS	DR	1,438.00	
(029326) 01-6537-0-5760-1180-5800-230-0000	Sped Learn Rec,PROF/CONS	CR		1,438.00
			1,438.00	1,438.00
JE # BR22-01626 JE Trans Date 06/07/2022 JE Posted 06/07/2022	Comment COVER EXPENSES			
(009529) 13-9010-0-0000-3700-4300-046-4606	OTHER RESTRICTE,MATERI	DR	1,600.00	
(025915) 13-9010-0-0000-3700-5800-046-4606	OTHER RESTRICTE,PROF/C	CR		1,600.00
			1,600.00	1,600.00
JE # BR22-01627 JE Trans Date 06/07/2022 JE Posted 06/07/2022	Comment BL-EWR 5177 MCDONALD,K MENTAL HLTH SP EWR4323			
(031522) 01-3219-0-1115-3110-2230-505-0000	ELO ESSERIII LL,CLASS PUF BL-EWR 5177 MCDONALD,K SUM.SCH.MENTAL HLTH SP EWR43237	CR		4,099.00
(031527) 01-3219-0-1115-3110-3312-505-0000	ELO ESSERIII LL,FICA:CLAS	CR		255.00
(031528) 01-3219-0-1115-3110-3332-505-0000	ELO ESSERIII LL,MEDICARE	CR		60.00
(031530) 01-3219-0-1115-3110-3502-505-0000	ELO ESSERIII LL,STATE UNE	CR		21.00
(031531) 01-3219-0-1115-3110-3602-505-0000	ELO ESSERIII LL,WORKERS'	CR		79.00

Selection Grouped by Org, Fiscal Year, JE# - Sorted by JE Item #, (Org = 14, JE Type = R, Starting Post Date = 6/1/2022, Ending Post Date = 7/31/2022, Unposted JEs? = N, End Bud Bal? = O, JE# Page Break? = N, Description? = A, Recap? = N)

ESCAPE ONLINE

Effective 04/14/2022 through 07/29/2022

Fiscal Year 2022

Account	Description	Comment	From	To
(continued) JE # BR22-01627 JE Trans Date 06/07/2022 JE Posted 06/07/2022 Comment BL-EWR 5177 MCDONALD,K MENTAL HLTH SP EWR4323				
(030156) 01-3219-0-1115-1000-4399-505-0000	ELO ESSERIII LL,HOLDING A	BL-EWR 5177 MCDONALD,K SUM.SCH.MENTAL HLTH SP EWR43237	DR	4,514.00
			4,514.00	4,514.00

Account	Description	Comment	From	To
JE # BR22-01628 JE Trans Date 06/07/2022 JE Posted 06/07/2022 Comment BL-EWR 4918 BAIOCCHI, D ADV BAND STIP EWR44003				
(025803) 01-0808-0-1380-4100-1160-831-0808	Measure U,CERT SALARY:ST		CR	1,230.00
(025803) 01-0808-0-1380-4100-1160-831-0808	Measure U,CERT SALARY:ST	BL-EWR 4918 BAIOCCHI, D BEG BAND STIP EWR44002	CR	858.00
(025804) 01-0808-0-1380-4100-3101-831-0808	Measure U,STRS:CERT,SCH	BL-EWR 4918 BAIOCCHI, D BEG BAND STIP EWR44002	CR	354.00
(025809) 01-0808-0-1380-4100-3331-831-0808	Measure U,MEDICARE:CERT	BL-EWR 4918 BAIOCCHI, D BEG BAND STIP EWR44002	CR	31.00
(025811) 01-0808-0-1380-4100-3501-831-0808	Measure U,STATE UNEMPLC	BL-EWR 4918 BAIOCCHI, D BEG BAND STIP EWR44002	CR	11.00
(025812) 01-0808-0-1380-4100-3601-831-0808	Measure U,WORKERS' COMF	BL-EWR 4918 BAIOCCHI, D BEG BAND STIP EWR44002	CR	40.00
(025228) 01-0808-0-1110-1000-4300-831-0808	Measure U,MATERIALS & SU	BL-EWR 4918 BAIOCCHI, D BEG/ADV BAND STIP EWR44002/3	DR	2,524.00
			2,524.00	2,524.00

Account	Description	Comment	From	To
JE # BR22-01629 JE Trans Date 06/03/2022 JE Posted 06/07/2022 Comment BL-DU88028				
(026777) 01-9010-0-5001-2110-4399-200-5640	OTHER RESTRICTE,HOLDIN	BL-DU88028 STATE OF CA MEDI-CAL CK30-806574 SEQ 027415383	CR	10,731.00
(026775) 01-9010-0-5001-0000-8699-200-5640	OTHER RESTRICTE,ALL OTI	BL-DU88028 STATE OF CA MEDI-CAL CK30-806574 SEQ 027415383	DR	10,731.00
(024157) 01-6388-0-6000-1000-5800-530-0000	Strong Workforc,PROF/CONS	BL-DU88028 CABRILLO CK83779 STRONG WRKFRCE K12 SWP R4 15769	CR	144,494.00
(032014) 01-6388-0-0000-0000-8590-530-0000	Strong Workforc,ALL OTHER	BL-DU88028 CABRILLO CK83779 STRONG WRKFRCE K12 SWP R4 15769	DR	144,494.00
(025847) 01-0150-0-1110-1000-4300-020-0000	MASTER/OTHER TE,MATERI	BL-DU88028 SJSU MSTR TCHR INV22-01333 CK712940	CR	1,120.00
(002971) 01-0150-0-0000-0000-8699-020-0000	MASTER/OTHER TE,ALL OTI	BL-DU88028 SJSU MSTR TCHR INV22-01333 CK712940	DR	1,120.00

Selection Grouped by Org, Fiscal Year, JE# - Sorted by JE Item #, (Org = 14, JE Type = R, Starting Post Date = 6/1/2022, Ending Post Date = 7/31/2022, Unposted JEs? = N, End Bud Bal? = O, JE# Page Break? = N, Description? = A, Recap? = N)

ESCAPE ONLINE

Effective 04/14/2022 through 07/29/2022

Fiscal Year 2022

Account	Description	Comment	From	To
(continued) JE # BR22-01629 JE Trans Date 06/03/2022 JE Posted 06/07/2022 Comment BL-DU88028				
(028133) 01-9010-0-1110-1000-4399-821- FLEX	OTHER RESTRICTE,HOLDIN	BL-DU88028 BV FLEX SC CNTY	CR	244.00
		CK533533 I.BAUTISTA		
(028051) 01-9010-0-0000-0000-8699-821- FLEX	OTHER RESTRICTE,ALL OT	BL-DU88028 BV FLEX SC CNTY	DR	244.00
		CK533533 I.BAUTISTA		
(008915) 01-9016-0-1150-1000-4300-027- 2706	DONATIONS,MATERIALS & S	BL-DU88028 WL SCI CAMP MS.	CR	292.00
		BATES CASH		
(008915) 01-9016-0-1150-1000-4300-027- 2706	DONATIONS,MATERIALS & S	BL-DU88028 WL SCI CAMP MR. SMITH	CR	292.00
		CASH		
(008476) 01-9016-0-0000-0000-8699-027- 2706	DONATIONS,ALL OTHER LO	BL-DU88028 WL SCI CAMP BATES/	DR	584.00
		SMITH CASH		
(008761) 01-9016-0-1110-1000-4300-031- 3156	DONATIONS,MATERIALS & S	BL-DU88028 BMS CK1229 KENGLE	CR	1,499.00
		\$200/CK846 ASB \$1298.85		
(008482) 01-9016-0-0000-0000-8699-031- 3156	DONATIONS,ALL OTHER LO	BL-DU88028 BMS CK1229 KENGLE	DR	1,499.00
		\$200/CK846 ASB \$1298.85		
(032016) 01-9010-0-1360-1000-5800-034- 3456	OTHER RESTRICTE,PROF/C	BL-DU88028 SCHS YEARBOOK	CR	5,030.00
		CKS/\$3340 CASH		
(029467) 01-9010-0-0000-0000-8699-034- 3456	OTHER RESTRICTE,ALL OT	BL-DU88028 SCHS YEARBOOK	DR	5,030.00
		CKS/\$3340 CASH		
(021806) 01-9051-0-1400-4200-4300-034- 0000	ASB FUNDS,MATERIALS & S	BL-DU88028 SCHS ASB Q2-3,	CR	4,989.00
		CK24691 INV22-01344		
(009229) 01-9051-0-0000-0000-8699-034- 0000	ASB FUNDS,ALL OTHER LO	BL-DU88028 SCHS ASB Q2-3,	DR	4,989.00
		CK24691 INV22-01344		
(008307) 01-9010-0-1190-1000-4300-034- 0089	OTHER RESTRICTE,MATERI	BL-DU88028 SCHS ENG LOST BKS	CR	290.00
(007564) 01-9010-0-0000-0000-8689-034- 0089	OTHER RESTRICTE,ALL OT	BL-DU88028 SCHS ENG LOST BKS	DR	290.00
(008293) 01-9010-0-1160-1000-4300-034- 0089	OTHER RESTRICTE,MATERI	BL-DU88028 SCHS MATH LOST	CR	110.00
		CALCULATOR		
(007564) 01-9010-0-0000-0000-8689-034- 0089	OTHER RESTRICTE,ALL OT	BL-DU88028 SCHS MATH LOST	DR	110.00
		CALCULATOR		
(007778) 01-9010-0-0000-2700-5800-034- 0088	OTHER RESTRICTE,PROF/C	BL-DU88028 SCHS PARKING	CR	40.00
(007585) 01-9010-0-0000-0000-8699-034- 0088	OTHER RESTRICTE,ALL OT	BL-DU88028 SCHS PARKING	DR	40.00
(007790) 01-9010-0-0000-3110-4300-034- 3405	OTHER RESTRICTE,MATERI	BL-DU88028 SCHS TRANSCRIPTS	CR	15.00
		CK620 KREPELA		
(007586) 01-9010-0-0000-0000-8699-034- 3405	OTHER RESTRICTE,ALL OT	BL-DU88028 SCHS TRANSCRIPTS	DR	15.00
		CK620 KREPELA		
(021807) 01-9051-0-1400-4200-4300-035- 0000	ASB FUNDS,MATERIALS & S	BL-DU88028 SHS ASB Q-2-3, CK6343	CR	11,158.00
		INV22-01358		
(009230) 01-9051-0-0000-0000-8699-035- 0000	ASB FUNDS,ALL OTHER LO	BL-DU88028 SHS ASB Q-2-3, CK6343	DR	11,158.00
		INV22-01358		

Selection Grouped by Org, Fiscal Year, JE# - Sorted by JE Item #, (Org = 14, JE Type = R, Starting Post Date = 6/1/2022, Ending Post Date = 7/31/2022, Unposted JEs? = N, End Bud Bal? = O, JE# Page Break? = N, Description? = A, Recap? = N)

ESCAPE ONLINE

Page 16 of 88

Effective 04/14/2022 through 07/29/2022

Fiscal Year 2022

Account		Description	Comment	From	To
(continued)	JE # BR22-01629	JE Trans Date 06/03/2022	JE Posted 06/07/2022	Comment BL-DU88028	
(008304)	01-9010-0-1190-1000-4200-035-0089	OTHER RESTRICTE,BOOKS	BL-DU88028 SHS ENG LOST BKS	CR	590.00
(008281)	01-9010-0-1150-1000-4200-035-0089	OTHER RESTRICTE,BOOKS	BL-DU88028 SHS SCI LOST BKS	CR	50.00
(008295)	01-9010-0-1180-1000-4200-035-0089	OTHER RESTRICTE,BOOKS	BL-DU88028 SHS W.LANG LOST BKS	CR	100.00
(007565)	01-9010-0-0000-0000-8689-035-0089	OTHER RESTRICTE,ALL OTI	BL-DU88028 SHS ENG/SCI/W.LANG LOST BKS	DR	740.00
(008388)	01-9010-0-3100-1000-4300-038-0061	OTHER RESTRICTE,MATERI	BL-DU88028 BSSC CHS CLOTHING	CR	480.00
(007592)	01-9010-0-0000-0000-8699-038-0061	OTHER RESTRICTE,ALL OTI	BL-DU88028 BSSC CHS CLOTHING	DR	480.00
(008621)	01-9016-0-0000-2700-4300-037-0051	DONATIONS,MATERIALS & S	BL-DU88028 BSSC GRAD DONATIONS	CR	365.00
(008521)	01-9016-0-0000-0000-8699-037-0051	DONATIONS,ALL OTHER LO	BL-DU88028 BSSC GRAD DONATIONS	DR	365.00
(008621)	01-9016-0-0000-2700-4300-037-0051	DONATIONS,MATERIALS & S	BL-DU88028 BSSC GRAD ARK I.S.DONATIONS	CR	630.00
(008521)	01-9016-0-0000-0000-8699-037-0051	DONATIONS,ALL OTHER LO	BL-DU88028 BSSC GRAD ARK I.S.DONATIONS	DR	630.00
(009219)	01-9016-0-8100-5900-5800-036-3611	DONATIONS,PROF/CONSUL	BL-DU88028 BSSC GRAD EMERGING JEDI AWARD	CR	1,000.00
(008520)	01-9016-0-0000-0000-8699-036-3611	DONATIONS,ALL OTHER LO	BL-DU88028 BSSC GRAD EMERGING JEDI AWARD	DR	1,000.00
(007924)	01-9010-0-0000-8110-4300-049-FACU	OTHER RESTRICTE,MATERI	BL-DU88028 SC FTBL CASH 4 INVOICES USE	CR	2,138.00
(007599)	01-9010-0-0000-0000-8699-049-FACU	OTHER RESTRICTE,ALL OTI	BL-DU88028 SC FTBL CASH 4 INVOICES USE	DR	2,138.00
(007943)	01-9010-0-0000-8200-2290-899-FACU	OTHER RESTRICTE,CLASS I	BL-DU88028 LIVE OAK SD CK999412 DEL MAR 10598559 O/C	CR	94.00
(007626)	01-9010-0-0000-0000-8699-899-FACU	OTHER RESTRICTE,ALL OTI	BL-DU88028 LIVE OAK SD CK999412 DEL MAR 10598559 O/C	DR	94.00
Net increase to Appropriations				.00	371,502.00

	JE # BR22-01630	JE Trans Date 06/03/2022	JE Posted 06/07/2022	Comment BL-DU88028 SJSU CK712940 INV22-01333 SPRING MSTR	
(025847)	01-0150-0-1110-1000-4300-020-0000	MASTER/OTHER TE,MATERI		DR	1,120.00
(002979)	01-0150-0-1110-1000-1160-020-0000	MASTER/OTHER TE,CERT S		CR	1,120.00
				1,120.00	1,120.00

	JE # BR22-01631	JE Trans Date 06/03/2022	JE Posted 06/07/2022	Comment BL-SCHS ASB Q2-3, INV22-01344 CK24691	
(031189)	01-9051-0-1400-4200-2160-034-0000	ASB FUNDS,CLASS INSTR A		CR	4,532.00

Selection Grouped by Org, Fiscal Year, JE# - Sorted by JE Item #, (Org = 14, JE Type = R, Starting Post Date = 6/1/2022, Ending Post Date = 7/31/2022, Unposted JEs? = N, End Bud Bal? = O, JE# Page Break? = N, Description? = A, Recap? = N)

ESCAPE ONLINE

Effective 04/14/2022 through 07/29/2022

Fiscal Year 2022

Account	Description	Comment	From	To
(continued) JE # BR22-01631 JE Trans Date 06/03/2022 JE Posted 06/07/2022		Comment BL-SCHS ASB Q2-3, INV22-01344 CK24691		
(009303) 01-9051-0-1400-4200-3312-034-0000	ASB FUNDS,FICA:CLASS,SC		CR	281.00
(009310) 01-9051-0-1400-4200-3332-034-0000	ASB FUNDS,MEDICARE:CLA		CR	66.00
(009317) 01-9051-0-1400-4200-3502-034-0000	ASB FUNDS,STATE UNEMPL		CR	23.00
(009324) 01-9051-0-1400-4200-3602-034-0000	ASB FUNDS,WORKERS' COM		CR	87.00
(021806) 01-9051-0-1400-4200-4300-034-0000	ASB FUNDS,MATERIALS & S		DR	4,989.00
				4,989.00
				4,989.00

JE # BR22-01632 JE Trans Date 06/07/2022 JE Posted 06/07/2022		Comment BL-SHS ASB Q-2-3, INV22-01358 CK6343		
(031175) 01-9051-0-1400-4200-2160-035-0000	ASB FUNDS,CLASS INSTR A		CR	6,645.00
(031315) 01-9051-0-1400-4200-1160-035-0000	ASB FUNDS,CERT SALARY:(CR	3,182.00
(031176) 01-9051-0-1400-4200-3101-035-0000	ASB FUNDS,STRS:CERT,SC		CR	539.00
(031180) 01-9051-0-1400-4200-3312-035-0000	ASB FUNDS,FICA:CLASS,SC		CR	412.00
(031317) 01-9051-0-1400-4200-3331-035-0000	ASB FUNDS,MEDICARE:CEF		CR	47.00
(031181) 01-9051-0-1400-4200-3332-035-0000	ASB FUNDS,MEDICARE:CLA		CR	97.00
(031319) 01-9051-0-1400-4200-3501-035-0000	ASB FUNDS,STATE UNEMPL		CR	16.00
(031183) 01-9051-0-1400-4200-3502-035-0000	ASB FUNDS,STATE UNEMPL		CR	34.00
(031320) 01-9051-0-1400-4200-3601-035-0000	ASB FUNDS,WORKERS' COM		CR	61.00
(031184) 01-9051-0-1400-4200-3602-035-0000	ASB FUNDS,WORKERS' COM		CR	128.00
(021807) 01-9051-0-1400-4200-4300-035-0000	ASB FUNDS,MATERIALS & S		DR	11,161.00
				11,161.00
				11,161.00

JE # BR22-01633 JE Trans Date 06/07/2022 JE Posted 06/07/2022		Comment JL-For Replacement Library Books		
(032053) 01-0000-0-3100-2420-4200-838-0004	NO REPORTING RE,BOOKS		CR	565.00
(002800) 01-0000-0-3100-3110-3401-838-0000	NO REPORTING RE,HEALTH		DR	565.00
				565.00
				565.00

JE # BR22-01634 JE Trans Date 06/07/2022 JE Posted 06/07/2022		Comment JL-For Library Replacement Books		
(032053) 01-0000-0-3100-2420-4200-838-0004	NO REPORTING RE,BOOKS		CR	65.00
(002800) 01-0000-0-3100-3110-3401-838-0000	NO REPORTING RE,HEALTH		DR	65.00
				65.00
				65.00

JE # BR22-01635 JE Trans Date 06/07/2022 JE Posted 06/07/2022		Comment BD-SUMMER SCHOOL HAPPY HOLLOW		
(032056) 01-3219-0-1115-1000-5800-505-0000	ELO ESSERIII LL,PROF/CON		CR	747.00
(030156) 01-3219-0-1115-1000-4399-505-0000	ELO ESSERIII LL,HOLDING A		DR	747.00

Selection Grouped by Org, Fiscal Year, JE# - Sorted by JE Item #, (Org = 14, JE Type = R, Starting Post Date = 6/1/2022, Ending Post Date = 7/31/2022, Unposted JEs? = N, End Bud Bal? = O, JE# Page Break? = N, Description? = A, Recap? = N)

ESCAPE ONLINE

Effective 04/14/2022 through 07/29/2022

Fiscal Year 2022

Account	Description	Comment	From	To
			747.00	747.00
JE # BR22-01636 JE Trans Date 06/07/2022 JE Posted 06/07/2022 Comment BL-DU88097				
(001153) 01-0000-0-0000-7300-4300-058-0000	NO REPORTING RE,MATERI	BL-DU88097 2080 MEDIA	CR	24.00
		CK63245313 PUBLIC RECORD FEE		
(021693) 01-0000-0-0000-0000-8699-058-0000	NO REPORTING RE,ALL OTI	BL-DU88097 2080 MEDIA	DR	24.00
		CK63245313 PUBLIC RECORD FEE		
(008734) 01-9016-0-1110-1000-4300-021-0051	DONATIONS,MATERIALS & S	BL-DU88097 BV CHAIR DON 3 CKS	CR	235.00
		\$75.33 EA, BOX TOPS \$8.70		
(008448) 01-9016-0-0000-0000-8699-021-0051	DONATIONS,ALL OTHER LO	BL-DU88097 BV CHAIR DON 3 CKS	DR	235.00
		\$75.33 EA, BOX TOPS \$8.70		
(032051) 01-9010-0-1110-2420-4200-021-0089	OTHER RESTRICTE,BOOKS	BL-DU88097 BV LIB BK FEE CK279	CR	40.00
		SANYAL, JAMIE		
(032054) 01-9010-0-0000-0000-8689-021-0089	OTHER RESTRICTE,ALL OTI	BL-DU88097 BV LIB BK FEE CK279	DR	40.00
		SANYAL, JAMIE		
(028133) 01-9010-0-1110-1000-4399-821-FLEX	OTHER RESTRICTE,HOLDIN	BL-DU88097 BV FLEX 2 CKS 121 \$383	CR	671.00
		BRONSON/CK2514 \$288 KUNKEL		
(028051) 01-9010-0-0000-0000-8699-821-FLEX	OTHER RESTRICTE,ALL OTI	BL-DU88097 BV FLEX 2 CKS 121 \$383	DR	671.00
		BRONSON/CK2514 \$288 KUNKEL		
(008216) 01-9010-0-1110-2420-4300-027-0089	OTHER RESTRICTE,MATERI	BL-DU88097 WL LIB BKS CK226 \$23	CR	38.00
		MOTT/CK487 \$15 BORN		
(007560) 01-9010-0-0000-0000-8689-027-0089	OTHER RESTRICTE,ALL OTI	BL-DU88097 WL LIB BKS CK226 \$23	DR	38.00
		MOTT/CK487 \$15 BORN		
(008117) 01-9010-0-1110-1000-4300-032-0089	OTHER RESTRICTE,MATERI	BL-DU88097 MHMS LIB CK3892	CR	130.00
		CORTAZZO/CK1374 KELLER		
(007562) 01-9010-0-0000-0000-8689-032-0089	OTHER RESTRICTE,ALL OTI	BL-DU88097 MHMS LIB CK3892	DR	130.00
		CORTAZZO/CK1374 KELLER		
(009035) 01-9016-0-1250-1000-4300-032-3266	DONATIONS,MATERIALS & S	BL-DU88097 MHMS BAND CK735	CR	140.00
		THOMPSON, ANGELA		
(008489) 01-9016-0-0000-0000-8699-032-3266	DONATIONS,ALL OTHER LO	BL-DU88097 MHMS BAND CK735	DR	140.00
		THOMPSON, ANGELA		
(032016) 01-9010-0-1360-1000-5800-034-3456	OTHER RESTRICTE,PROF/C	BL-DU88097 SCHS YEARBOOKS	CR	90.00
		CASH		
(029467) 01-9010-0-0000-0000-8699-034-3456	OTHER RESTRICTE,ALL OTI	BL-DU88097 SCHS YEARBOOKS	DR	90.00
		CASH		
(008307) 01-9010-0-1190-1000-4300-034-0089	OTHER RESTRICTE,MATERI	BL-DU88097 SCHS ENG LOST BK	CR	15.00
		CASH		
(008298) 01-9010-0-1180-1000-4300-034-0089	OTHER RESTRICTE,MATERI	BL-DU88097 SCHS SPANISH LOST	CR	95.00
		BK CK4333 MEHL		

Selection Grouped by Org, Fiscal Year, JE# - Sorted by JE Item #, (Org = 14, JE Type = R, Starting Post Date = 6/1/2022, Ending Post Date = 7/31/2022, Unposted JEs? = N, End Bud Bal? = O, JE# Page Break? = N, Description? = A, Recap? = N)

ESCAPE ONLINE

Effective 04/14/2022 through 07/29/2022

Fiscal Year 2022

Account	Description	Comment	From	To
(continued) JE # BR22-01636 JE Trans Date 06/07/2022 JE Posted 06/07/2022 Comment BL-DU88097				
(007564) 01-9010-0-0000-0000-8689-034-0089	OTHER RESTRICTE,ALL OTI BL-DU88097 SCHS ENGSPANISH LOST BKS	DR		110.00
(031576) 01-9010-0-0000-2700-4300-033-3309	OTHER RESTRICTE,MATERI BL-DU88097 HHS SALES/SASHES	CR		200.00
(032055) 01-9010-0-0000-0000-8699-033-3309	OTHER RESTRICTE,ALL OTI BL-DU88097 HHS SALES/SASHES	DR		200.00
(015935) 01-9016-0-1110-1000-4300-033-3317	DONATIONS,MATERIALS & CKS/CASH BL-DU88097 HHS YEARBOOK	CR		5,450.00
(016442) 01-9016-0-0000-0000-8699-033-3317	DONATIONS,ALL OTHER LO BL-DU88097 HHS YEARBOOK CKS/CASH	DR		5,450.00
(008772) 01-9016-0-1110-1000-4300-033-0051	DONATIONS,MATERIALS & CKS/CASH BL-DU88097 HHS SWAG CASH	CR		3.00
(008490) 01-9016-0-0000-0000-8699-033-0051	DONATIONS,ALL OTHER LO BL-DU88097 HHS SWAG CASH	DR		3.00
(007981) 01-9010-0-0000-8300-4300-033-0088	OTHER RESTRICTE,MATERI BL-DU88097 HHS PARKING	CR		180.00
(007582) 01-9010-0-0000-0000-8699-033-0088	OTHER RESTRICTE,ALL OTI BL-DU88097 HHS PARKING	DR		180.00
(007788) 01-9010-0-0000-3110-4300-033-0088	OTHER RESTRICTE,MATERI BL-DU88097 HHS TRANSCRIPTS	CR		40.00
(007582) 01-9010-0-0000-0000-8699-033-0088	OTHER RESTRICTE,ALL OTI BL-DU88097 HHS TRANSCRIPTS	DR		40.00
(008084) 01-9010-0-1110-1000-4100-033-0089	OTHER RESTRICTE,APPR T BL-DU88097 HHS BOOKS	CR		564.00
(007563) 01-9010-0-0000-0000-8689-033-0089	OTHER RESTRICTE,ALL OTI BL-DU88097 HHS BOOKS	DR		564.00
(008621) 01-9016-0-0000-2700-4300-037-0051	DONATIONS,MATERIALS & CKS/CASH BL-DU88097 BSSC GRAD DON.CK1679 SCHENDLEDECKER	CR		150.00
(008521) 01-9016-0-0000-0000-8699-037-0051	DONATIONS,ALL OTHER LO BL-DU88097 BSSC GRAD DON.CK1679 SCHENDLEDECKER	DR		150.00
Net increase to Appropriations			.00	16,130.00

JE # BR22-01637 JE Trans Date 06/08/2022 JE Posted 06/08/2022 Comment BD-TO COVER TRANFER OF EXPENDITURES			
(018316) 01-0000-0-0000-2110-5800-620-0000	NO REPORTING RE,PROF/C	DR	1,516.00
(000911) 01-0000-0-0000-3140-3202-620-0000	NO REPORTING RE,PERS:C	DR	131.00
(000959) 01-0000-0-0000-3140-3502-620-0000	NO REPORTING RE,STATE I	DR	4.00
(001608) 01-0000-0-1110-1000-1130-620-0000	NO REPORTING RE,CERT S	DR	3,106.00
(001682) 01-0000-0-1110-1000-3101-620-0000	NO REPORTING RE,STRS:C	DR	526.00
(001770) 01-0000-0-1110-1000-3331-620-0000	NO REPORTING RE,MEDICA	DR	45.00
(001829) 01-0000-0-1110-1000-3501-620-0000	NO REPORTING RE,STATE I	DR	38.00
(001877) 01-0000-0-1110-1000-3601-620-0000	NO REPORTING RE,WORKE	DR	62.00
(001969) 01-0000-0-1110-1000-5200-620-0000	NO REPORTING RE,TRAVEL	DR	292.00
(032057) 01-0000-0-0000-3110-5800-620-0000	NO REPORTING RE,PROF/C	CR	5,720.00
5,720.00			5,720.00

JE # BR22-01638 JE Trans Date 06/08/2022 JE Posted 06/08/2022 Comment BD-SUMMER SCHOOL EWRS
--

Selection Grouped by Org, Fiscal Year, JE# - Sorted by JE Item #, (Org = 14, JE Type = R, Starting Post Date = 6/1/2022, Ending Post Date = 7/31/2022, Unposted JEs? = N, End Bud Bal? = O, JE# Page Break? = N, Description? = A, Recap? = N)

ESCAPE ONLINE

Effective 04/14/2022 through 07/29/2022

Fiscal Year 2022

Account	Description	Comment	From	To
(continued) JE # BR22-01638 JE Trans Date 06/08/2022 JE Posted 06/08/2022		Comment BD-SUMMER SCHOOL EWRS		
(031100) 01-3010-0-1115-1000-1130-505-0000	BAS GNT LOW-INC,CERT SA	CR		4,680.00
(031101) 01-3010-0-1115-1000-3101-505-0000	BAS GNT LOW-INC,STRS:CE	CR		792.00
(031106) 01-3010-0-1115-1000-3331-505-0000	BAS GNT LOW-INC,MEDICAF	CR		68.00
(031108) 01-3010-0-1115-1000-3501-505-0000	BAS GNT LOW-INC,STATE U	CR		23.00
(031109) 01-3010-0-1115-1000-3601-505-0000	BAS GNT LOW-INC,WORKEF	CR		91.00
(027608) 01-3010-0-1110-1000-4399-520-0000	BAS GNT LOW-INC,HOLDINC	DR	5,654.00	
			5,654.00	5,654.00

JE # BR22-01639 JE Trans Date 06/08/2022 JE Posted 06/08/2022	Comment BD- COAST PAPER SUPPLY INVOICES AT VARIOUS SIT			
(001453) 01-0000-0-0000-8200-4300-831-0000	NO REPORTING RE,MATERI	CR		49.00
(001449) 01-0000-0-0000-8200-4300-821-0000	NO REPORTING RE,MATERI	CR		436.00
(001457) 01-0000-0-0000-8200-4300-835-0000	NO REPORTING RE,MATERI	CR		1,216.00
(001450) 01-0000-0-0000-8200-4300-823-0000	NO REPORTING RE,MATERI	CR		209.00
(001455) 01-0000-0-0000-8200-4300-833-0000	NO REPORTING RE,MATERI	CR		3,657.00
(001454) 01-0000-0-0000-8200-4300-832-0000	NO REPORTING RE,MATERI	CR		1,349.00
	Net increase to Appropriations		.00	6,916.00

JE # BR22-01640 JE Trans Date 06/08/2022 JE Posted 06/08/2022	Comment JL-Adjust Revenue based on Est. Actuals received 5/20/22			
(005331) 01-3311-0-5001-0000-8181-220-0000	SE:LOCAL ASSIST,SE:ENTIT	CR	1,722.00	
(005333) 01-3311-0-5760-1180-5800-220-0000	SE:LOCAL ASSIST,PROF/CC	DR	1,722.00	
(004962) 01-3310-0-5001-0000-8181-220-0000	SE:LOCAL ASSIST,SE:ENTIT	CR	27,844.00	
(004964) 01-3310-0-5001-0000-8980-220-0000	SE:LOCAL ASSIST,CONTRI F	DR		27,844.00
(005350) 01-3315-0-5730-0000-8182-220-0000	SE:PRESCHOOL GR,SE:DISC	CR	1,262.00	
(014733) 01-3315-0-5730-3150-5800-220-0000	SE:PRESCHOOL GR,PROF/C	DR	1,262.00	
(006277) 01-6500-0-5001-0000-8792-220-0000	SE:STATE LOCAL,APPORT >	DR		70,808.00
(006279) 01-6500-0-5001-0000-8980-220-0000	SE:STATE LOCAL,CONTRI F	CR	70,808.00	
(000055) 01-0000-0-0000-0000-8980-020-0000	NO REPORTING RE,CONTRI	DR		42,964.00
(005332) 01-3311-0-5001-0000-8181-230-0000	SE:LOCAL ASSIST,SE:ENTIT	CR	615.00	
(011765) 01-3311-0-5760-1180-5800-230-0000	SE:LOCAL ASSIST,PROF/CC	DR	615.00	
(004963) 01-3310-0-5001-0000-8181-230-0000	SE:LOCAL ASSIST,SE:ENTIT	CR	361,243.00	
(004965) 01-3310-0-5001-0000-8980-230-0000	SE:LOCAL ASSIST,CONTRI F	DR		361,243.00
(006278) 01-6500-0-5001-0000-8792-230-0000	SE:STATE LOCAL,APPORT >	DR		248,107.00
(006280) 01-6500-0-5001-0000-8980-230-0000	SE:STATE LOCAL,CONTRI F	CR	248,107.00	
(000058) 01-0000-0-0000-0000-8980-030-0000	NO REPORTING RE,CONTRI	CR	113,136.00	

Effective 04/14/2022 through 07/29/2022

Fiscal Year 2022

Account	Description	Comment	From	To
---------	-------------	---------	------	----

Net decrease to Appropriations 828,336.00 750,966.00

JE #	BR22-01641	JE Trans Date	06/08/2022	JE Posted	06/08/2022	Comment	JL-Add Budget for Res 3305 ARP IDEA	
(032068)	01-3305-0-5001-0000-8182-220-0000	SE:LOC ASST ARP,SE:DISCF				DR	66,301.00	
(032071)	01-3305-0-5001-7210-7310-220-0000	SE:LOC ASST ARP,XFER:INI				CR	4,349.00	
(032073)	01-3305-0-5760-1110-1100-220-0000	SE:LOC ASST ARP,CERT:TE				CR	61,952.00	
(032070)	01-3305-0-5001-0000-8182-230-0000	SE:LOC ASST ARP,SE:DISCF				DR	175,074.00	
(032072)	01-3305-0-5001-7210-7310-230-0000	SE:LOC ASST ARP,XFER:INI				CR	11,484.00	
(032083)	01-3305-0-5760-1110-1100-230-0000	SE:LOC ASST ARP,CERT:TE				CR	163,590.00	
(032093)	01-3308-0-5730-0000-8182-220-0000	SE:FDPRESCH ARP,SE:DISC				DR	19,409.00	
(032095)	01-3308-0-5730-7210-7310-220-0000	SE:FDPRESCH ARP,XFER:IN				CR	1,273.00	
(032096)	01-3308-0-5730-3150-5800-220-0000	SE:FDPRESCH ARP,PROF/C				CR	18,136.00	
(001138)	01-0000-0-0000-7210-7310-899-0000	NO REPORTING RE,XFER:IN				DR	17,106.00	
Net increase to Appropriations							<u>17,106.00</u>	<u>521,568.00</u>

JE #	BR22-01642	JE Trans Date	06/09/2022	JE Posted	06/09/2022	Comment	BD-EWR 44414 & COVER NEGATIVES	
(031245)	01-0700-0-0000-3110-1240-032-0000	LCFF SUPP FUNDI,CERT PU				CR	1,584.00	
(024798)	01-0700-0-0000-3110-3311-032-0000	LCFF SUPP FUNDI,FICA:CEF				CR	70.00	
(024799)	01-0700-0-0000-3110-3331-032-0000	LCFF SUPP FUNDI,MEDICAF				CR	22.00	
(024801)	01-0700-0-0000-3110-3501-032-0000	LCFF SUPP FUNDI,STATE U				CR	8.00	
(024802)	01-0700-0-0000-3110-3601-032-0000	LCFF SUPP FUNDI,WORKER				CR	30.00	
(003361)	01-0700-0-1110-1000-1100-032-0000	LCFF SUPP FUNDI,CERT:TE				CR	1.00	
(003376)	01-0700-0-1110-1000-1130-032-0000	LCFF SUPP FUNDI,CERT SA				CR	360.00	
(003386)	01-0700-0-1110-1000-1140-032-0000	LCFF SUPP FUNDI,CERT SA				CR	573.00	
(003449)	01-0700-0-1110-1000-3101-032-0000	LCFF SUPP FUNDI,STRS:CE				CR	147.00	
(003482)	01-0700-0-1110-1000-3311-032-0000	LCFF SUPP FUNDI,FICA:CEF				CR	12.00	
(003513)	01-0700-0-1110-1000-3331-032-0000	LCFF SUPP FUNDI,MEDICAF				CR	15.00	
(003562)	01-0700-0-1110-1000-3501-032-0000	LCFF SUPP FUNDI,STATE U				CR	5.00	
(003597)	01-0700-0-1110-1000-3601-032-0000	LCFF SUPP FUNDI,WORKER				CR	21.00	
(003645)	01-0700-0-1110-1000-4300-032-0000	LCFF SUPP FUNDI,MATERIA				DR	2,848.00	
Net increase to Appropriations							<u>2,848.00</u>	<u>2,848.00</u>

JE #	BR22-01643	JE Trans Date	06/09/2022	JE Posted	06/09/2022	Comment	BD-EWR 43238
(030763)	01-3219-0-1115-1000-1130-550-0000	ELO ESSERIII LL,CERT SALA				DR	4,518.00
(031512)	01-3219-0-1115-3110-2230-550-0000	ELO ESSERIII LL,CLASS PUF				CR	4,099.00
(031517)	01-3219-0-1115-3110-3312-550-0000	ELO ESSERIII LL,FICA:CLAS				CR	255.00

Selection Grouped by Org, Fiscal Year, JE# - Sorted by JE Item #, (Org = 14, JE Type = R, Starting Post Date = 6/1/2022, Ending Post Date = 7/31/2022, Unposted JEs? = N, End Bud Bal? = O, JE# Page Break? = N, Description? = A, Recap? = N)

ESCAPE ONLINE

Page 22 of 88

Effective 04/14/2022 through 07/29/2022

Fiscal Year 2022

Account	Description	Comment	From	To
JE # BR22-01643 JE Trans Date 06/09/2022 JE Posted 06/09/2022 Comment BD-EWR 43238				
(031518) 01-3219-0-1115-3110-3332-550-0000	ELO ESSERIII LL,MEDICARE	CR		60.00
(031520) 01-3219-0-1115-3110-3502-550-0000	ELO ESSERIII LL,STATE UNE	CR		21.00
(031521) 01-3219-0-1115-3110-3602-550-0000	ELO ESSERIII LL,WORKERS'	CR		83.00
			4,518.00	4,518.00
JE # BR22-01644 JE Trans Date 06/09/2022 JE Posted 06/09/2022 Comment BD- EWR 44346 CAMERON				
(024133) 01-4203-0-1110-1000-4399-530-0000	ESEA:ENGLISH LE,HOLDINC	DR	436.00	
(031686) 01-4203-0-1195-1000-1130-530-0000	ESEA:ENGLISH LE,CERT SA	CR		360.00
(031687) 01-4203-0-1195-1000-3101-530-0000	ESEA:ENGLISH LE,STRS:CE	CR		61.00
(031692) 01-4203-0-1195-1000-3331-530-0000	ESEA:ENGLISH LE,MEDICAF	CR		6.00
(031694) 01-4203-0-1195-1000-3501-530-0000	ESEA:ENGLISH LE,STATE U	CR		2.00
(031695) 01-4203-0-1195-1000-3601-530-0000	ESEA:ENGLISH LE,WORKER	CR		7.00
			436.00	436.00
JE # BR22-01645 JE Trans Date 06/09/2022 JE Posted 06/09/2022 Comment BD-EWR 44455 BROWN				
(026710) 01-3213-0-1110-1000-1130-530-0000	ESSER III ARP,CERT SALAR	DR	68.00	
(029200) 01-3213-0-1200-1000-1130-530-0000	ESSER III ARP,CERT SALAR	CR		54.00
(029201) 01-3213-0-1200-1000-3101-530-0000	ESSER III ARP,STRS:CERT,I	CR		10.00
(029206) 01-3213-0-1200-1000-3331-530-0000	ESSER III ARP,MEDICARE:C	CR		1.00
(029208) 01-3213-0-1200-1000-3501-530-0000	ESSER III ARP,STATE UNEM	CR		1.00
(029209) 01-3213-0-1200-1000-3601-530-0000	ESSER III ARP,WORKERS' C	CR		2.00
			68.00	68.00
JE # BR22-01646 JE Trans Date 06/10/2022 JE Posted 06/10/2022 Comment COVER EXPENSES				
(025667) 01-6500-0-5760-1110-5800-205-0000	SE:STATE LOCAL,PROF/COI	DR	100.00	
(006648) 01-6500-0-5760-1110-4300-205-0000	SE:STATE LOCAL ,MATERIA	CR		100.00
			100.00	100.00
JE # BR22-01647 JE Trans Date 06/10/2022 JE Posted 06/10/2022 Comment FOOD FOR LEADERSHIP				
(001066) 01-0000-0-0000-7110-5800-053-0000	NO REPORTING RE,PROF/C	DR	500.00	
(001103) 01-0000-0-0000-7150-4395-053-0000	NO REPORTING RE,FOOD F	CR		500.00
			500.00	500.00

Selection Grouped by Org, Fiscal Year, JE# - Sorted by JE Item #, (Org = 14, JE Type = R, Starting Post Date = 6/1/2022, Ending Post Date = 7/31/2022, Unposted JEs? = N, End Bud Bal? = O, JE# Page Break? = N, Description? = A, Recap? = N)

ESCAPE ONLINE

Effective 04/14/2022 through 07/29/2022

Fiscal Year 2022

Account	Description	Comment	From	To
JE # BR22-01648 JE Trans Date 06/13/2022 JE Posted 06/13/2022 Comment BD-SUMMER SCHOOL BUS SEYMORE MARINE CENTER				
(032052) 01- 3219- 0- 1115- 1000- 5710- 505- 0000	ELO ESSERIII LL,XFER OF D		CR	188.00
(030156) 01- 3219- 0- 1115- 1000- 4399- 505- 0000	ELO ESSERIII LL,HOLDING A		DR	188.00
			188.00	188.00
JE # BR22-01649 JE Trans Date 06/13/2022 JE Posted 06/13/2022 Comment R22-02612				
(011467) 21- 9734- 0- 0000- 8500- 6202- 023- B010	BOND A ELEM,MODERNIZAT		CR	10,833.00
(010424) 21- 9734- 0- 0000- 8500- 6200- 000- 0000	BOND A ELEM,BUILDINGS &		CR	10,833.00
Net increase to Appropriations			.00	21,666.00

JE # BR22-01650 JE Trans Date 06/14/2022 JE Posted 06/14/2022 Comment BD-COVER NEGATIVES & BIOLOGY COLLAB. TIME				
(003389) 01- 0700- 0- 1110- 1000- 1140- 035- 0000	LCFF SUPP FUNDI,CERT SA		CR	5,188.00
(029707) 01- 0700- 0- 1110- 1000- 2930- 035- 0000	LCFF SUPP FUNDI,OTHER C		CR	1,087.00
(003452) 01- 0700- 0- 1110- 1000- 3101- 035- 0000	LCFF SUPP FUNDI,STRS:CE		CR	846.00
(013760) 01- 0700- 0- 1110- 1000- 3311- 035- 0000	LCFF SUPP FUNDI,FICA:CEF		CR	66.00
(003516) 01- 0700- 0- 1110- 1000- 3331- 035- 0000	LCFF SUPP FUNDI,MEDICAF		CR	116.00
(003565) 01- 0700- 0- 1110- 1000- 3501- 035- 0000	LCFF SUPP FUNDI,STATE U		CR	40.00
(003600) 01- 0700- 0- 1110- 1000- 3601- 035- 0000	LCFF SUPP FUNDI,WORKER		CR	153.00
(020314) 01- 0700- 0- 1110- 1000- 3602- 035- 0000	LCFF SUPP FUNDI,WORKER		CR	4.00
(032099) 01- 0700- 0- 1150- 1000- 1130- 035- 0000	LCFF SUPP FUNDI,CERT SA		CR	648.00
(032100) 01- 0700- 0- 1150- 1000- 3101- 035- 0000	LCFF SUPP FUNDI,STRS:CE		CR	110.00
(032105) 01- 0700- 0- 1150- 1000- 3331- 035- 0000	LCFF SUPP FUNDI,MEDICAF		CR	10.00
(032107) 01- 0700- 0- 1150- 1000- 3501- 035- 0000	LCFF SUPP FUNDI,STATE U		CR	4.00
(032108) 01- 0700- 0- 1150- 1000- 3601- 035- 0000	LCFF SUPP FUNDI,WORKER		CR	13.00
(018792) 01- 0700- 0- 1110- 1000- 1130- 035- 0000	LCFF SUPP FUNDI,CERT SA		DR	8,285.00
			8,285.00	8,285.00

JE # BR22-01651 JE Trans Date 06/14/2022 JE Posted 06/14/2022 Comment BL-OSS PAYMENTS				
(008934) 01- 9016- 0- 1150- 1000- 5800- 027- 2706	DONATIONS,PROF/CONSUL		CR	21,933.00
(008915) 01- 9016- 0- 1150- 1000- 4300- 027- 2706	DONATIONS,MATERIALS & S		DR	21,933.00
(032109) 01- 9016- 0- 1150- 1000- 5800- 027- 0051	DONATIONS,PROF/CONSUL		CR	309.00
(008755) 01- 9016- 0- 1110- 1000- 4300- 027- 0051	DONATIONS,MATERIALS & S		DR	309.00
			22,242.00	22,242.00

JE # BR22-01652 JE Trans Date 06/15/2022 JE Posted 06/15/2022 Comment BD-TO COVER UNPAID INVOICES				
--	--	--	--	--

Selection Grouped by Org, Fiscal Year, JE# - Sorted by JE Item #, (Org = 14, JE Type = R, Starting Post Date = 6/1/2022, Ending Post Date = 7/31/2022, Unposted JEs? = N, End Bud Bal? = O, JE# Page Break? = N, Description? = A, Recap? = N)

ESCAPE ONLINE

Effective 04/14/2022 through 07/29/2022

Fiscal Year 2022

Account	Description	Comment	From	To
(continued) JE # BR22-01652 JE Trans Date 06/15/2022 JE Posted 06/15/2022		Comment BD-TO COVER UNPAID INVOICES		
(022087) 01- 0809- 0- 1400- 4200- 4300- 035- 0807	Measure T,MATERIALS & SU	CR		1,400.00
(022088) 01- 0809- 0- 1400- 4200- 5800- 035- 0807	Measure T,PROF/CONSULT	DR	1,046.00	
(022086) 01- 0809- 0- 1270- 4100- 4300- 035- 0807	Measure T,MATERIALS & SU	DR	354.00	
			1,400.00	1,400.00
JE # BR22-01653 JE Trans Date 06/15/2022 JE Posted 06/15/2022		Comment JL-For Replacement Books at Monarch		
(002765) 01- 0000- 0- 3100- 1000- 4300- 825- 0000	NO REPORTING RE,MATERI	CR		1,200.00
(002814) 01- 0000- 0- 3200- 1000- 3401- 836- 0000	NO REPORTING RE,HEALTH	DR	1,200.00	
			1,200.00	1,200.00
JE # BR22-01654 JE Trans Date 06/15/2022 JE Posted 06/15/2022		Comment JL-For JV Baseball Field Fencing at SHS		
(032111) 01- 9010- 0- 1400- 4200- 5800- 035- FACU	OTHER RESTRICTE,PROF/C	CR		18,575.00
(007924) 01- 9010- 0- 0000- 8110- 4300- 049- FACU	OTHER RESTRICTE,MATERI	DR	18,575.00	
			18,575.00	18,575.00
JE # BR22-01655 JE Trans Date 06/15/2022 JE Posted 06/15/2022		Comment JL-For Jr. Ed Techs at each sec site		
(025993) 01- 0000- 0- 0000- 2420- 2230- 831- 0000	NO REPORTING RE,CLASS I	CR		6,600.00
(026003) 01- 0000- 0- 0000- 2420- 2230- 832- 0000	NO REPORTING RE,CLASS I	CR		6,600.00
(026013) 01- 0000- 0- 0000- 2420- 2230- 833- 0000	NO REPORTING RE,CLASS I	CR		6,600.00
(026023) 01- 0000- 0- 0000- 2420- 2230- 834- 0000	NO REPORTING RE,CLASS I	CR		6,600.00
(026062) 01- 0000- 0- 0000- 2420- 2230- 835- 0000	NO REPORTING RE,CLASS I	CR		6,600.00
(032113) 01- 0000- 0- 0000- 2420- 2230- 838- 0000	NO REPORTING RE,CLASS I	CR		3,300.00
(001624) 01- 0000- 0- 1110- 1000- 1140- 831- 0000	NO REPORTING RE,CERT S.	DR	6,600.00	
(001337) 01- 0000- 0- 0000- 8200- 2200- 832- 0000	NO REPORTING RE,CLASS:I	DR	4,872.00	
(001371) 01- 0000- 0- 0000- 8200- 3202- 832- 0000	NO REPORTING RE,PERS:C	DR	1,728.00	
(001815) 01- 0000- 0- 1110- 1000- 3401- 833- 0000	NO REPORTING RE,HEALTH	DR	6,600.00	
(001412) 01- 0000- 0- 0000- 8200- 3402- 834- 0000	NO REPORTING RE,HEALTH	DR	6,600.00	
(000367) 01- 0000- 0- 0000- 2700- 2400- 835- 0000	NO REPORTING RE,CLERIC.	DR	2,917.00	
(000404) 01- 0000- 0- 0000- 2700- 3101- 835- 0000	NO REPORTING RE,STRS:C	DR	3,683.00	
(000355) 01- 0000- 0- 0000- 2700- 1300- 838- 0000	NO REPORTING RE,CERT:S	DR	3,300.00	
			36,300.00	36,300.00
JE # BR22-01656 JE Trans Date 06/15/2022 JE Posted 06/15/2022		Comment JL-For Jr. Ed Techs at various sites		
(032110) 01- 0000- 0- 0000- 2420- 2230- 857- 0000	NO REPORTING RE,CLASS I	CR		36,300.00

Selection Grouped by Org, Fiscal Year, JE# - Sorted by JE Item #, (Org = 14, JE Type = R, Starting Post Date = 6/1/2022, Ending Post Date = 7/31/2022, Unposted JEs? = N, End Bud Bal? = O, JE# Page Break? = N, Description? = A, Recap? = N)

ESCAPE ONLINE

Effective 04/14/2022 through 07/29/2022

Fiscal Year 2022

Account	Description	Comment	From	To
(continued) JE # BR22-01656 JE Trans Date 06/15/2022 JE Posted 06/15/2022	Comment JL-For Jr. Ed Techs at various sites			
(001315) 01-0000-0-0000-7700-5900-857-0000	NO REPORTING RE,COMMU	DR	36,300.00	
			36,300.00	36,300.00
JE # BR22-01657 JE Trans Date 06/15/2022 JE Posted 06/15/2022	Comment BL-GAEL SUM SCH BUS TR2287, TR2288 6/2, 6/9			
(003976) 01-0723-0-0000-3600-5710-048-0000	TRANSPORT:HOME,XFER O	DR	802.00	
(003941) 01-0723-0-0000-0000-8980-030-0000	TRANSPORT:HOME,CONTRI	CR	802.00	
(000054) 01-0000-0-0000-0000-8980-000-0000	NO REPORTING RE,CONTRI	DR		802.00
Net decrease to Appropriations			1,604.00	802.00
JE # BR22-01658 JE Trans Date 06/15/2022 JE Posted 06/15/2022	Comment BL-3453 C.WATERS SUM SCH PBIS 6/1-30/22 EWR44879			
(031545) 01-3010-0-1115-1000-2130-505-0000	BAS GNT LOW-INC,CLASS IN	CR		2,329.00
(031546) 01-3010-0-1115-1000-3312-505-0000	BAS GNT LOW-INC,FICA:CL/	CR		145.00
(031547) 01-3010-0-1115-1000-3332-505-0000	BAS GNT LOW-INC,MEDICAF	CR		34.00
(031549) 01-3010-0-1115-1000-3502-505-0000	BAS GNT LOW-INC,STATE U	CR		12.00
(031550) 01-3010-0-1115-1000-3602-505-0000	BAS GNT LOW-INC,WORKEF	CR		45.00
(027608) 01-3010-0-1110-1000-4399-520-0000	BAS GNT LOW-INC,HOLDINC	DR	2,565.00	
			2,565.00	2,565.00
JE # BR22-01659 JE Trans Date 06/15/2022 JE Posted 06/15/2022	Comment BL-GAEL SUM SCH SUB EWR44880/882 HERNANDEZ/TH			
(032123) 01-3010-0-1115-1000-2140-505-0000	BAS GNT LOW-INC,CLASS IN	CR		1,282.00
(031546) 01-3010-0-1115-1000-3312-505-0000	BAS GNT LOW-INC,FICA:CL/	CR		80.00
(031547) 01-3010-0-1115-1000-3332-505-0000	BAS GNT LOW-INC,MEDICAF	CR		19.00
(031549) 01-3010-0-1115-1000-3502-505-0000	BAS GNT LOW-INC,STATE U	CR		7.00
(031550) 01-3010-0-1115-1000-3602-505-0000	BAS GNT LOW-INC,WORKEF	CR		25.00
(027608) 01-3010-0-1110-1000-4399-520-0000	BAS GNT LOW-INC,HOLDINC	DR	1,413.00	
			1,413.00	1,413.00
JE # BR22-01660 JE Trans Date 06/16/2022 JE Posted 06/16/2022	Comment R22-02647			
(014564) 21-9733-0-0000-8500-6280-034-B102	BOND A SECONDAR,CONST	CR		101,449.00
(009895) 21-9733-0-0000-8500-6200-000-0000	BOND A SECONDAR,BUILDII	CR		101,449.00
Net increase to Appropriations			.00	202,898.00
JE # BR22-01661 JE Trans Date 06/16/2022 JE Posted 06/16/2022	Comment PO22-00313			

Selection Grouped by Org, Fiscal Year, JE# - Sorted by JE Item #, (Org = 14, JE Type = R, Starting Post Date = 6/1/2022, Ending Post Date = 7/31/2022, Unposted JEs? = N, End Bud Bal? = O, JE# Page Break? = N, Description? = A, Recap? = N)

ESCAPE ONLINE

Effective 04/14/2022 through 07/29/2022

Fiscal Year 2022

Account	Description	Comment	From	To
(continued) JE # BR22-01661 JE Trans Date 06/16/2022 JE Posted 06/16/2022 Comment PO22-00313				
(022827) 21-9733-0-0000-8500-6202-034- B166	BOND A SECONDAR,MODEF		CR	38,352.00
(009895) 21-9733-0-0000-8500-6200-000-0000	BOND A SECONDAR,BUILDII		CR	38,352.00
Net increase to Appropriations			.00	76,704.00
JE # BR22-01662 JE Trans Date 06/16/2022 JE Posted 06/16/2022 Comment PO22-01597				
(019151) 21-9734-0-0000-8500-6202-027- B160	BOND A ELEM,MODERNIZA1		CR	3,564.00
(010424) 21-9734-0-0000-8500-6200-000-0000	BOND A ELEM,BUILDINGS &		CR	3,564.00
Net increase to Appropriations			.00	7,128.00
JE # BR22-01663 JE Trans Date 06/16/2022 JE Posted 06/16/2022 Comment PO22-02140				
(028045) 21-9733-0-0000-8500-6201-030- B506	BOND A SECONDAR,NEW C		CR	28,629.00
(009895) 21-9733-0-0000-8500-6200-000-0000	BOND A SECONDAR,BUILDII		CR	28,629.00
Net increase to Appropriations			.00	57,258.00
JE # BR22-01664 JE Trans Date 06/16/2022 JE Posted 06/16/2022 Comment R22-02647				
(014564) 21-9733-0-0000-8500-6280-034- B102	BOND A SECONDAR,CONST		CR	42,620.00
(009895) 21-9733-0-0000-8500-6200-000-0000	BOND A SECONDAR,BUILDII		CR	42,620.00
Net increase to Appropriations			.00	85,240.00
JE # BR22-01665 JE Trans Date 06/16/2022 JE Posted 06/16/2022 Comment PO22-00337				
(023997) 21-9733-0-0000-8500-6202-034- B165	BOND A SECONDAR,MODEF		CR	8,674.00
(009895) 21-9733-0-0000-8500-6200-000-0000	BOND A SECONDAR,BUILDII		CR	8,674.00
Net increase to Appropriations			.00	17,348.00
JE # BR22-01666 JE Trans Date 06/16/2022 JE Posted 06/16/2022 Comment R22-02648				
(032124) 21-9733-0-0000-8500-6280-030- B501	Bond A Secondar,CONSTRUC		CR	10,432.00
(009895) 21-9733-0-0000-8500-6200-000-0000	BOND A SECONDAR,BUILDII		CR	10,432.00
Net increase to Appropriations			.00	20,864.00
JE # BR22-01667 JE Trans Date 06/16/2022 JE Posted 06/16/2022 Comment R22-02649				
(032125) 21-9734-0-0000-8500-6202-021- B033	Bond A Elem,MODERNIZATIC		CR	37,073.00
(010424) 21-9734-0-0000-8500-6200-000-0000	BOND A ELEM,BUILDINGS &		CR	37,073.00

Selection Grouped by Org, Fiscal Year, JE# - Sorted by JE Item #, (Org = 14, JE Type = R, Starting Post Date = 6/1/2022, Ending Post Date = 7/31/2022, Unposted JEs? = N, End Bud Bal? = O, JE# Page Break? = N, Description? = A, Recap? = N)

ESCAPE ONLINE

Page 27 of 88

Effective 04/14/2022 through 07/29/2022

Fiscal Year 2022

Account	Description	Comment	From	To
Net increase to Appropriations			.00	74,146.00
JE # BR22-01668 JE Trans Date 06/16/2022 JE Posted 06/16/2022 Comment R22-02649				
(032126) 21-9734-0-0000-8500-6202-024-B157	Bond A Elem,MODERNIZATIC		CR	30,334.00
(010424) 21-9734-0-0000-8500-6200-000-0000	BOND A ELEM,BUILDINGS &		CR	30,334.00
Net increase to Appropriations			.00	60,668.00
JE # BR22-01669 JE Trans Date 06/16/2022 JE Posted 06/16/2022 Comment R22-02651				
(032032) 21-9734-0-0000-8500-6202-021-B006	Bond A Elem,MODERNIZATIC		CR	26,628.00
(010424) 21-9734-0-0000-8500-6200-000-0000	BOND A ELEM,BUILDINGS &		CR	26,628.00
Net increase to Appropriations			.00	53,256.00
JE # BR22-01670 JE Trans Date 06/16/2022 JE Posted 06/16/2022 Comment R22-02650				
(028137) 21-9734-0-0000-8500-6202-023-B012	BOND A ELEM,MODERNIZA1		CR	15,715.00
(010424) 21-9734-0-0000-8500-6200-000-0000	BOND A ELEM,BUILDINGS &		CR	15,715.00
Net increase to Appropriations			.00	31,430.00
JE # BR22-01671 JE Trans Date 06/16/2022 JE Posted 06/16/2022 Comment R22-02652				
(012621) 21-9733-0-0000-8500-6202-032-B119	BOND A SECONDAR,MODEF		CR	100,900.00
(009895) 21-9733-0-0000-8500-6200-000-0000	BOND A SECONDAR,BUILDII		CR	100,900.00
Net increase to Appropriations			.00	201,800.00
JE # BR22-01672 JE Trans Date 06/16/2022 JE Posted 06/16/2022 Comment R22-02653				
(017919) 21-9733-0-0000-8500-6202-031-B419	BOND A SECONDAR,MODEF		CR	117,500.00
(009895) 21-9733-0-0000-8500-6200-000-0000	BOND A SECONDAR,BUILDII		CR	117,500.00
Net increase to Appropriations			.00	235,000.00
JE # BR22-01673 JE Trans Date 06/16/2022 JE Posted 06/16/2022 Comment R22-02654				
(032127) 21-9733-0-0000-8500-6290-034-B102	Bond A Secondar,INSCPECTI		CR	333,600.00
(009895) 21-9733-0-0000-8500-6200-000-0000	BOND A SECONDAR,BUILDII		CR	333,600.00
Net increase to Appropriations			.00	667,200.00
JE # BR22-01674 JE Trans Date 06/16/2022 JE Posted 06/16/2022 Comment R22-02646				

Selection Grouped by Org, Fiscal Year, JE# - Sorted by JE Item #, (Org = 14, JE Type = R, Starting Post Date = 6/1/2022, Ending Post Date = 7/31/2022, Unposted JEs? = N, End Bud Bal? = O, JE# Page Break? = N, Description? = A, Recap? = N)

ESCAPE ONLINE

Effective 04/14/2022 through 07/29/2022

Fiscal Year 2022

Account	Description	Comment	From	To
(continued) JE # BR22-01674 JE Trans Date 06/16/2022 JE Posted 06/16/2022 Comment R22-02646				
(010144) 21- 9733- 0- 0000- 8500- 6220- 034- B114	BOND A SECONDAR,DSA PL		CR	1,615.00
(009895) 21- 9733- 0- 0000- 8500- 6200- 000- 0000	BOND A SECONDAR,BUILDII		CR	1,615.00
Net increase to Appropriations			.00	3,230.00

Account	Description	Comment	From	To
JE # BR22-01675 JE Trans Date 06/16/2022 JE Posted 06/16/2022 Comment BL-DU88349				
(026777) 01- 9010- 0- 5001- 2110- 4399- 200- 5640	OTHER RESTRICTE,HOLDIN BL-DU88349 STATE OF CA MEDI-CAL		CR	6,025.00
	CK30-812580			
(026775) 01- 9010- 0- 5001- 0000- 8699- 200- 5640	OTHER RESTRICTE,ALL OTI BL-DU88349 STATE OF CA MEDI-CAL		DR	6,025.00
	CK30-812580			
(028133) 01- 9010- 0- 1110- 1000- 4399- 821- FLEX	OTHER RESTRICTE,HOLDIN BL-DU88349 BV FLEX CNTY SC		CR	321.00
	CK533623 MAY'22 I.BAUTISTA			
(028051) 01- 9010- 0- 0000- 0000- 8699- 821- FLEX	OTHER RESTRICTE,ALL OTI BL-DU88349 BV FLEX CNTY SC		DR	321.00
	CK533623 MAY'22 I.BAUTISTA			
(008761) 01- 9016- 0- 1110- 1000- 4300- 031- 3156	DONATIONS,MATERIALS & S BL-DU88349 BMS HM SCH CK1080		CR	564.00
	TR2283 BUS FOR P.E.			
(008482) 01- 9016- 0- 0000- 0000- 8699- 031- 3156	DONATIONS,ALL OTHER LO BL-DU88349 BMS HM SCH CK1080		DR	564.00
	TR2283 BUS FOR P.E.			
(003956) 01- 0723- 0- 0000- 3600- 2290- 848- 0000	TRANSPORT:HOME,CLASS I BL-DU88349 PACIFIC ELEM BUS		CR	473.00
	INV2201341 4/28/22			
(003940) 01- 0723- 0- 0000- 0000- 8699- 848- 0000	TRANSPORT:HOME,ALL OTI BL-DU88349 PACIFIC ELEM BUS		DR	473.00
	INV2201341 4/28/22			
Net increase to Appropriations			.00	14,766.00

Account	Description	Comment	From	To
JE # BR22-01676 JE Trans Date 06/16/2022 JE Posted 06/16/2022 Comment BL-DU88349 SCCOE TCHR LEADRSH INV22-01357				
(008009) 01- 9010- 0- 1110- 1000- 1160- 520- 0080	OTHER RESTRICTE,CERT S.		CR	8,100.00
(008010) 01- 9010- 0- 1110- 1000- 1160- 530- 0080	OTHER RESTRICTE,CERT S.		CR	3,400.00
(008018) 01- 9010- 0- 1110- 1000- 3101- 520- 0080	OTHER RESTRICTE,STRS:C		CR	923.00
(008020) 01- 9010- 0- 1110- 1000- 3101- 530- 0080	OTHER RESTRICTE,STRS:C		CR	499.00
(008030) 01- 9010- 0- 1110- 1000- 3311- 520- 0080	OTHER RESTRICTE,FICA:CE		CR	9.00
(008031) 01- 9010- 0- 1110- 1000- 3311- 530- 0080	OTHER RESTRICTE,FICA:CE		CR	19.00
(008041) 01- 9010- 0- 1110- 1000- 3331- 520- 0080	OTHER RESTRICTE,MEDICA		CR	118.00
(008043) 01- 9010- 0- 1110- 1000- 3331- 530- 0080	OTHER RESTRICTE,MEDICA		CR	49.00
(008056) 01- 9010- 0- 1110- 1000- 3501- 520- 0080	OTHER RESTRICTE,STATE I		CR	41.00
(008058) 01- 9010- 0- 1110- 1000- 3501- 530- 0080	OTHER RESTRICTE,STATE I		CR	17.00
(008071) 01- 9010- 0- 1110- 1000- 3601- 520- 0080	OTHER RESTRICTE,WORKE		CR	155.00
(008073) 01- 9010- 0- 1110- 1000- 3601- 530- 0080	OTHER RESTRICTE,WORKE		CR	65.00

Selection Grouped by Org, Fiscal Year, JE# - Sorted by JE Item #, (Org = 14, JE Type = R, Starting Post Date = 6/1/2022, Ending Post Date = 7/31/2022, Unposted JEs? = N, End Bud Bal? = O, JE# Page Break? = N, Description? = A, Recap? = N)

ESCAPE ONLINE

Effective 04/14/2022 through 07/29/2022

Fiscal Year 2022

Account	Description	Comment	From	To
(continued) JE # BR22-01676 JE Trans Date 06/16/2022 JE Posted 06/16/2022		Comment BL-DU88349 SCCOE TCHR LEADRSH	INV22-01357	
(007609) 01-9010-0-0000-0000-8699-520-0080	OTHER RESTRICTE,ALL OTI		DR	9,345.00
(007610) 01-9010-0-0000-0000-8699-530-0080	OTHER RESTRICTE,ALL OTI		DR	4,050.00
Net increase to Appropriations			.00	26,790.00

JE # BR22-01677 JE Trans Date 06/16/2022 JE Posted 06/16/2022	Comment BL-DU88349			
(009245) 01-9051-0-0000-2700-2430-031-0000	ASB FUNDS,CLASS CLERIC/	BL-DU88349 BMS ASB Q-2,Q-3	CR	55.00
		INV22-01347 CK834		
(009251) 01-9051-0-0000-2700-3332-031-0000	ASB FUNDS,MEDICARE:CLA	BL-DU88349 BMS ASB Q-2,Q-3	CR	1.00
		INV22-01347 CK834		
(009254) 01-9051-0-0000-2700-3502-031-0000	ASB FUNDS,STATE UNEMPL	BL-DU88349 BMS ASB Q-2,Q-3	CR	1.00
		INV22-01347 CK834		
(009257) 01-9051-0-0000-2700-3602-031-0000	ASB FUNDS,WORKERS' COI	BL-DU88349 BMS ASB Q-2,Q-3	CR	1.00
		INV22-01347 CK834		
(017175) 01-9051-0-0000-2700-3102-031-0000	ASB FUNDS,STRS:CLASSIFI	BL-DU88349 BMS ASB Q-2,Q-3	CR	10.00
		INV22-01347 CK834		
(009226) 01-9051-0-0000-0000-8699-031-0000	ASB FUNDS,ALL OTHER LO	BL-DU88349 BMS ASB Q-2,Q-3	DR	66.00
		INV22-01347 CK834		
(027642) 01-9051-0-1400-4200-4300-031-0000	ASB FUNDS,MATERIALS & S	BL-DU88349 BMS ASB COVER NEG.	DR	3.00
(009248) 01-9051-0-0000-2700-3312-031-0000	ASB FUNDS,FICA:CLASS,SC	BL-DU88349 BMS ASB Q-2,Q-3	CR	1.00
		INV22-01347 CK834		
Net increase to Appropriations			3.00	135.00

JE # BR22-01678 JE Trans Date 06/16/2022 JE Posted 06/16/2022	Comment BL-EWR 5196 AUSTIN,KAT SUM SCH 5/16-6/30 PARA AF			
(031545) 01-3010-0-1115-1000-2130-505-0000	BAS GNT LOW-INC,CLASS I		CR	2,973.00
(031546) 01-3010-0-1115-1000-3312-505-0000	BAS GNT LOW-INC,FICA:CL		CR	185.00
(031547) 01-3010-0-1115-1000-3332-505-0000	BAS GNT LOW-INC,MEDICAF		CR	44.00
(031549) 01-3010-0-1115-1000-3502-505-0000	BAS GNT LOW-INC,STATE U		CR	15.00
(031550) 01-3010-0-1115-1000-3602-505-0000	BAS GNT LOW-INC,WORKEF		CR	57.00
(027608) 01-3010-0-1110-1000-4399-520-0000	BAS GNT LOW-INC,HOLDINC		DR	3,274.00
Net increase to Appropriations			3,274.00	3,274.00

JE # BR22-01679 JE Trans Date 06/17/2022 JE Posted 06/17/2022	Comment BD-SCHOLARSHIPS			
(011007) 73-0983-0-8100-5900-5800-000-0000	LOMA PRIETA SCH,PROF/C		CR	250.00
Net increase to Appropriations			.00	250.00

Selection Grouped by Org, Fiscal Year, JE# - Sorted by JE Item #, (Org = 14, JE Type = R, Starting Post Date = 6/1/2022, Ending Post Date = 7/31/2022, Unposted JEs? = N, End Bud Bal? = O, JE# Page Break? = N, Description? = A, Recap? = N)

ESCAPE ONLINE

Effective 04/14/2022 through 07/29/2022

Fiscal Year 2022

Account	Description	Comment	From	To
JE # BR22-01680 JE Trans Date 06/16/2022 JE Posted 06/17/2022 Comment OSS PARENT REFUND				
(008934) 01- 9016- 0- 1150- 1000- 5800- 027- 2706	DONATIONS,PROF/CONSUL	CR		584.00
(008915) 01- 9016- 0- 1150- 1000- 4300- 027- 2706	DONATIONS,MATERIALS & S	DR	584.00	
			584.00	584.00
JE # BR22-01681 JE Trans Date 06/20/2022 JE Posted 06/20/2022 Comment R22092649				
(032125) 21- 9734- 0- 0000- 8500- 6202- 021- B033	Bond A Elem,MODERNIZATIC	CR		1.00
(010424) 21- 9734- 0- 0000- 8500- 6200- 000- 0000	BOND A ELEM,BUILDINGS &	CR		1.00
			Net increase to Appropriations	2.00
JE # BR22-01682 JE Trans Date 06/20/2022 JE Posted 06/20/2022 Comment ACCO-WILSON OPEN PO REPAIRS PLUMBING HVAC				
(007542) 01- 8150- 0- 0000- 8110- 6400- 049- 0000	ONGOING & MAJOR,EQUIPM	DR	7,650.00	
(007539) 01- 8150- 0- 0000- 8110- 5600- 049- 0000	ONGOING & MAJOR,RENTAI	CR		7,650.00
			7,650.00	7,650.00
JE # BR22-01683 JE Trans Date 06/20/2022 JE Posted 06/20/2022 Comment TOYOTA MATERIAL HANDLING OPEN PO GOLF CART RE				
(007542) 01- 8150- 0- 0000- 8110- 6400- 049- 0000	ONGOING & MAJOR,EQUIPM	DR	8,336.00	
(007539) 01- 8150- 0- 0000- 8110- 5600- 049- 0000	ONGOING & MAJOR,RENTAI	CR		8,336.00
			8,336.00	8,336.00
JE # BR22-01684 JE Trans Date 06/20/2022 JE Posted 06/20/2022 Comment TOYOTA MATERIAL HANDLING OPEN PO GOLF CART RE				
(007543) 01- 8150- 0- 0000- 8110- 6500- 049- 0000	ONGOING & MAJOR,EQUIPM	DR	2,240.00	
(007539) 01- 8150- 0- 0000- 8110- 5600- 049- 0000	ONGOING & MAJOR,RENTAI	CR		2,240.00
			2,240.00	2,240.00
JE # BR22-01685 JE Trans Date 06/20/2022 JE Posted 06/20/2022 Comment BD-SCHOLARSHIPS				
(011007) 73- 0983- 0- 8100- 5900- 5800- 000- 0000	LOMA PRIETA SCH,PROF/C	CR		250.00
			Net increase to Appropriations	250.00
JE # BR22-01686 JE Trans Date 06/21/2022 JE Posted 06/21/2022 Comment BD-COVER NEGATIVES				
(031780) 01- 6010- 0- 0000- 2495- 5800- 524- 0000	AFTER-SCHOOL ED,PROF/C	CR		322.00
(024088) 01- 6010- 0- 1110- 1000- 4300- 524- 0000	AFTER-SCHOOL ED,MATERI	DR	322.00	

Selection Grouped by Org, Fiscal Year, JE# - Sorted by JE Item #, (Org = 14, JE Type = R, Starting Post Date = 6/1/2022, Ending Post Date = 7/31/2022, Unposted JEs? = N, End Bud Bal? = O, JE# Page Break? = N, Description? = A, Recap? = N)

ESCAPE ONLINE

Effective 04/14/2022 through 07/29/2022

Fiscal Year 2022

Account	Description	Comment	From	To
			322.00	322.00
JE # BR22-01687 JE Trans Date 06/21/2022 JE Posted 06/21/2022 Comment ABACHERLI FENCE SQHS JV BASEBALL FIELD				
(007924)	01-9010-0-0000-8110-4300-049- FACU	OTHER RESTRICTE,MATERI	DR	20,000.00
(032152)	01-9010-0-0000-8110-5800-035- FACU	OTHER RESTRICTE,PROF/C	CR	20,000.00
			20,000.00	20,000.00
JE # BR22-01688 JE Trans Date 06/21/2022 JE Posted 06/21/2022 Comment JL-For L w-o t books for Replacement				
(016112)	01-0000-0-3100-1000-4300-825-0004	NO REPORTING RE,MATERI	CR	1,170.00
(002814)	01-0000-0-3200-1000-3401-836-0000	NO REPORTING RE,HEALTH	DR	1,170.00
			1,170.00	1,170.00
JE # BR22-01689 JE Trans Date 06/10/2022 JE Posted 06/21/2022 Comment BL-4699 TORRES, JORGE EWR 43253 Sprg Seussical 202				
(011946)	01-9016-0-1250-1000-2130-035-3551	DONATIONS,CLASS INSTR A	CR	1,512.00
(014192)	01-9016-0-1250-1000-3102-035-3551	DONATIONS,STRS:CLASSIF	CR	256.00
(011515)	01-9016-0-1250-1000-3332-035-3551	DONATIONS,MEDICARE:CLA	CR	22.00
(011463)	01-9016-0-1250-1000-3502-035-3551	DONATIONS,STATE UNEMPI	CR	8.00
(011537)	01-9016-0-1250-1000-3602-035-3551	DONATIONS,WORKERS' CO	CR	29.00
(017761)	01-9016-0-1250-1000-4300-035-3551	DONATIONS,MATERIALS & S	DR	1,827.00
			1,827.00	1,827.00
JE # BR22-01690 JE Trans Date 06/21/2022 JE Posted 06/21/2022 Comment SUMMER SCHOOL FIELD TRIPS				
(030156)	01-3219-0-1115-1000-4399-505-0000	ELO ESSERIII LL,HOLDING A	DR	2,281.00
(032056)	01-3219-0-1115-1000-5800-505-0000	ELO ESSERIII LL,PROF/CON	CR	2,281.00
			2,281.00	2,281.00
JE # BR22-01691 JE Trans Date 06/22/2022 JE Posted 06/22/2022 Comment BD- TO CLOSE ER				
(000170)	01-0000-0-0000-2110-5200-530-0000	NO REPORTING RE,TRAVEL	CR	1.00
(016571)	01-0000-0-1110-1000-4395-530-0000	NO REPORTING RE,FOOD F	DR	1.00
			1.00	1.00
JE # BR22-01692 JE Trans Date 06/22/2022 JE Posted 06/22/2022 Comment BD-TO CLOSE ER				
(000887)	01-0000-0-0000-3140-1230-600-0000	NO REPORTING RE,CERT P	DR	1.00
(000995)	01-0000-0-0000-3140-5200-600-0000	NO REPORTING RE,TRAVEL	CR	1.00
			1.00	1.00
Selection	Grouped by Org, Fiscal Year, JE# - Sorted by JE Item #, (Org = 14, JE Type = R, Starting Post Date = 6/1/2022, Ending Post Date = 7/31/2022, Unposted JEs? = N, End Bud Bal? = O, JE# Page Break? = N, Description? = A, Recap? = N)			ESCAPE ONLINE

Effective 04/14/2022 through 07/29/2022

Fiscal Year 2022

Account	Description	Comment	From	To
			1.00	1.00
JE # BR22-01693 JE Trans Date 06/22/2022 JE Posted 06/22/2022 Comment ST-BSN Sports Budget				
(032165)	01- 0809- 0- 1400- 4200- 4400- 035- 0807	Measure T,NON-CAPITALIZE	CR	1,127.00
(022088)	01- 0809- 0- 1400- 4200- 5800- 035- 0807	Measure T,PROF/CONSULT	CR	1,392.00
(022087)	01- 0809- 0- 1400- 4200- 4300- 035- 0807	Measure T,MATERIALS & SU	DR	2,517.00
(015665)	01- 0809- 0- 1400- 4200- 4300- 830- 0809	Measure T,MATERIALS & SU	DR	2.00
			2,519.00	2,519.00

JE # BR22-01694 JE Trans Date 06/23/2022 JE Posted 06/23/2022 Comment SJ-EMP REIMB - TRAVEL				
(008288)	01- 9010- 0- 1150- 1000- 4300- 500- 4050	OTHER RESTRICTE,MATERI	DR	907.00
(018763)	01- 9010- 0- 1150- 1000- 5200- 520- 4050	OTHER RESTRICTE,TRAVEL	CR	907.00
(014592)	01- 0000- 0- 1110- 1000- 5800- 530- 0000	NO REPORTING RE,PROF/C SJ-EMP REIMB	DR	38.00
(000170)	01- 0000- 0- 0000- 2110- 5200- 530- 0000	NO REPORTING RE,TRAVEL SJ-EMP REIMB	CR	38.00
(011147)	01- 0000- 0- 1110- 1000- 5800- 520- 0000	NO REPORTING RE,PROF/C SJ-EMP REIMB	DR	65.00
(001967)	01- 0000- 0- 1110- 1000- 5200- 520- 0000	NO REPORTING RE,TRAVEL SJ-EMP REIMB	CR	65.00
			1,010.00	1,010.00

JE # BR22-01695 JE Trans Date 06/24/2022 JE Posted 06/24/2022 Comment SJ-SUMMER CAMP BOWLING FIELDTRIP				
(030156)	01- 3219- 0- 1115- 1000- 4399- 505- 0000	ELO ESSERIII LL,HOLDING A	DR	702.00
(032056)	01- 3219- 0- 1115- 1000- 5800- 505- 0000	ELO ESSERIII LL,PROF/CON	CR	702.00
			702.00	702.00

JE # BR22-01696 JE Trans Date 06/23/2022 JE Posted 06/24/2022 Comment BL-DU88505				
(026777)	01- 9010- 0- 5001- 2110- 4399- 200- 5640	OTHER RESTRICTE,HOLDIN BL-DU88505 STATE OF CA MEDI-CAL	CR	12,805.00
		CK30-823339 SEQ027432151		
(026775)	01- 9010- 0- 5001- 0000- 8699- 200- 5640	OTHER RESTRICTE,ALL OTI BL-DU88505 STATE OF CA MEDI-CAL	DR	12,805.00
		CK30-823339 SEQ027432151		
(003956)	01- 0723- 0- 0000- 3600- 2290- 848- 0000	TRANSPORT:HOME,CLASS I BL-DU88505 COASTAL WATERSHED	CR	703.00
		CK21070 INV22-01352 BUS		
(003940)	01- 0723- 0- 0000- 0000- 8699- 848- 0000	TRANSPORT:HOME,ALL OTI BL-DU88505 COASTAL WATERSHED	DR	703.00
		CK21070 INV22-01352 BUS		
(003956)	01- 0723- 0- 0000- 3600- 2290- 848- 0000	TRANSPORT:HOME,CLASS I BL-DU88505 LIVE OAK BUS	CR	517.00
		INV22-01340 CK1001320		
(003940)	01- 0723- 0- 0000- 0000- 8699- 848- 0000	TRANSPORT:HOME,ALL OTI BL-DU88505 LIVE OAK BUS	DR	517.00
		INV22-01340 CK1001320		

Selection Grouped by Org, Fiscal Year, JE# - Sorted by JE Item #, (Org = 14, JE Type = R, Starting Post Date = 6/1/2022, Ending Post Date = 7/31/2022, Unposted JEs? = N, End Bud Bal? = O, JE# Page Break? = N, Description? = A, Recap? = N)

ESCAPE ONLINE

Page 33 of 88

Effective 04/14/2022 through 07/29/2022

Fiscal Year 2022

Account		Description	Comment	From	To
(continued)	JE # BR22-01696	JE Trans Date 06/23/2022	JE Posted 06/24/2022	Comment BL-DU88505	
(003956)	01-0723-0-0000-3600-2290-848-0000	TRANSPORT:HOME,CLASS I	BL-DU88505 LIVE OAK BUS	CR	85.00
			INV22-01350 CK1001320		
(003940)	01-0723-0-0000-0000-8699-848-0000	TRANSPORT:HOME,ALL OT	BL-DU88505 LIVE OAK BUS	DR	85.00
			INV22-01350 CK1001320		
(028133)	01-9010-0-1110-1000-4399-821-FLEX	OTHER RESTRICTE,HOLDIN	BL-DU88505 GO KIDS CK91859	CR	654.00
			APRIL-RITTER, JAKE & TEO		
(028051)	01-9010-0-0000-0000-8699-821-FLEX	OTHER RESTRICTE,ALL OT	BL-DU88505 GO KIDS CK91859	DR	654.00
			APRIL-RITTER, JAKE & TEO		
(028133)	01-9010-0-1110-1000-4399-821-FLEX	OTHER RESTRICTE,HOLDIN	BL-DU88505 GO KIDS CK91870	CR	654.00
			MAY-RITTER, JAKE & TEO		
(028051)	01-9010-0-0000-0000-8699-821-FLEX	OTHER RESTRICTE,ALL OT	BL-DU88505 GO KIDS CK91870	DR	654.00
			MAY-RITTER, JAKE & TEO		
(028133)	01-9010-0-1110-1000-4399-821-FLEX	OTHER RESTRICTE,HOLDIN	BL-DU88505 BV FLEX SCCS REVOLV	CR	4,124.00
			FUND CK38117 APRIL		
(028134)	01-9010-0-1110-1000-4399-824-FLEX	OTHER RESTRICTE,HOLDIN	BL-DU88505 GA FLEX SCCS REVOLV	CR	3,420.00
			FUND CK38117 APRIL		
(028051)	01-9010-0-0000-0000-8699-821-FLEX	OTHER RESTRICTE,ALL OT	BL-DU88505 BV FLEX SCCS REVOLV	DR	4,124.00
			FUND CK38117 APRIL		
(028052)	01-9010-0-0000-0000-8699-824-FLEX	OTHER RESTRICTE,ALL OT	BL-DU88505 GA FLEX SCCS REVOLV	DR	3,420.00
			FUND CK38117 APRIL		
(028133)	01-9010-0-1110-1000-4399-821-FLEX	OTHER RESTRICTE,HOLDIN	BL-DU88505 BV FLEX SCCS REVOLV	CR	5,084.00
			FUND CK38118 MAY		
(028051)	01-9010-0-0000-0000-8699-821-FLEX	OTHER RESTRICTE,ALL OT	BL-DU88505 BV FLEX SCCS REVOLV	DR	5,084.00
			FUND CK38118 MAY		
(028134)	01-9010-0-1110-1000-4399-824-FLEX	OTHER RESTRICTE,HOLDIN	BL-DU88505 GA FLEX SCCS REVOLV	CR	2,889.00
			FUND CK38118 MAY		
(028052)	01-9010-0-0000-0000-8699-824-FLEX	OTHER RESTRICTE,ALL OT	BL-DU88505 GA FLEX SCCS REVOLV	DR	2,889.00
			FUND CK38118 MAY		
(007943)	01-9010-0-0000-8200-2290-899-FACU	OTHER RESTRICTE,CLASS I	BL-DU88505 SC ARTS COUN	CR	470.00
			CK63535562 9769339 O/C		
(007626)	01-9010-0-0000-0000-8699-899-FACU	OTHER RESTRICTE,ALL OT	BL-DU88505 SC ARTS COUN	DR	470.00
			CK63535562 9769339 O/C		
(007924)	01-9010-0-0000-8110-4300-049-FACU	OTHER RESTRICTE,MATERI	BL-DU88505 SC SWIMMING CK6894	CR	175.00
			6997362 USE		
(007599)	01-9010-0-0000-0000-8699-049-FACU	OTHER RESTRICTE,ALL OT	BL-DU88505 SC SWIMMING CK6894	DR	175.00
			6997362 USE		
(007924)	01-9010-0-0000-8110-4300-049-FACU	OTHER RESTRICTE,MATERI	BL-DU88505 SC SWIMMING CK6896	CR	2,507.00
			13635867/181368/13476516 USE		

Selection Grouped by Org, Fiscal Year, JE# - Sorted by JE Item #, (Org = 14, JE Type = R, Starting Post Date = 6/1/2022, Ending Post Date = 7/31/2022, Unposted JEs? = N, End Bud Bal? = O, JE# Page Break? = N, Description? = A, Recap? = N)

ESCAPE ONLINE

Page 34 of 88

Effective 04/14/2022 through 07/29/2022

Fiscal Year 2022

Account	Description	Comment	From	To
(continued) JE # BR22-01696 JE Trans Date 06/23/2022 JE Posted 06/24/2022 Comment BL-DU88505				
(007599) 01- 9010- 0- 0000- 0000- 8699- 049- FACU	OTHER RESTRICTE,ALL OTI	BL-DU88505 SC SWIM CK6896 13635867/181368/13476516 USE	DR	2,507.00
(007924) 01- 9010- 0- 0000- 8110- 4300- 049- FACU	OTHER RESTRICTE,MATERI	BL-DU88505 SC SWIMMING CK6898 15657313/1820028 USE	CR	2,083.00
(007599) 01- 9010- 0- 0000- 0000- 8699- 049- FACU	OTHER RESTRICTE,ALL OTI	BL-DU88505 SC SWIMMING CK6898 15657313/1820028 USE	DR	2,083.00
(007924) 01- 9010- 0- 0000- 8110- 4300- 049- FACU	OTHER RESTRICTE,MATERI	BL-DU88505 SC MASTERS AQUATICS CK1994 10253069USE	CR	188.00
(007599) 01- 9010- 0- 0000- 0000- 8699- 049- FACU	OTHER RESTRICTE,ALL OTI	BL-DU88505 SC MASTERS AQUATICS CK1994 10253069USE	DR	188.00
(007943) 01- 9010- 0- 0000- 8200- 2290- 899- FACU	OTHER RESTRICTE,CLASS I	BL-DU88505 SC MASTERS AQUATICS CK1994 10253069 O/C	CR	47.00
(007626) 01- 9010- 0- 0000- 0000- 8699- 899- FACU	OTHER RESTRICTE,ALL OTI	BL-DU88505 SC MASTERS AQUATICS CK1994 10253069 O/C	DR	47.00
(007924) 01- 9010- 0- 0000- 8110- 4300- 049- FACU	OTHER RESTRICTE,MATERI	BL-DU88505 SC BREAKERS (PREM FUTBOL) CK6286 18 INV USE	CR	9,047.00
(007599) 01- 9010- 0- 0000- 0000- 8699- 049- FACU	OTHER RESTRICTE,ALL OTI	BL-DU88505 SC BREAKERS CK6286 18 INV USE	DR	9,047.00
(007924) 01- 9010- 0- 0000- 8110- 4300- 049- FACU	OTHER RESTRICTE,MATERI	BL-DU88505 SC BREAKERS CK1051 (SC PREMIER) 8 INV USE	CR	720.00
(007599) 01- 9010- 0- 0000- 0000- 8699- 049- FACU	OTHER RESTRICTE,ALL OTI	BL-DU88505 SC BREAKERS CK1051 (SC PREMIER) 8 INV USE	DR	720.00
Net increase to Appropriations			.00	92,344.00

JE # BR22-01697 JE Trans Date 06/24/2022 JE Posted 06/24/2022 Comment BL-GA SUMMER SCH BUS TR2289/TR2290 6/23, 6/30/22				
(030156) 01- 3219- 0- 1115- 1000- 4399- 505- 0000	ELO ESSERIII LL,HOLDING A		DR	355.00
(032052) 01- 3219- 0- 1115- 1000- 5710- 505- 0000	ELO ESSERIII LL,XFER OF D	BL-GA SUMMER SCH BUS TR28289/TR2290 6/23, 6/30/22	CR	355.00
(003976) 01- 0723- 0- 0000- 3600- 5710- 048- 0000	TRANSPORT:HOME,XFER O	BL-GA SUMMER SCH BUS TR28289/TR2290 6/23, 6/30/22	DR	355.00
(003941) 01- 0723- 0- 0000- 0000- 8980- 030- 0000	TRANSPORT:HOME,CONTRI	BL-GA SUMMER SCH BUS TR28289/TR2290 6/23, 6/30/22	CR	355.00
(000054) 01- 0000- 0- 0000- 0000- 8980- 000- 0000	NO REPORTING RE,CONTRI	BL-GA SUMMER SCH BUS TR28289/TR2290 6/23, 6/30/22	DR	355.00
Net decrease to Appropriations			1,065.00	710.00

JE # BR22-01698 JE Trans Date 06/24/2022 JE Posted 06/24/2022 Comment BD-TO COVER INVOICES PO22-00883				
--	--	--	--	--

Selection Grouped by Org, Fiscal Year, JE# - Sorted by JE Item #, (Org = 14, JE Type = R, Starting Post Date = 6/1/2022, Ending Post Date = 7/31/2022, Unposted JEs? = N, End Bud Bal? = O, JE# Page Break? = N, Description? = A, Recap? = N)

ESCAPE ONLINE

Page 35 of 88

Effective 04/14/2022 through 07/29/2022

Fiscal Year 2022

Account	Description	Comment	From	To
JE # BR22-01698 JE Trans Date 06/24/2022 JE Posted 06/24/2022 Comment BD-TO COVER INVOICES PO22-00883				
(continued) (001937) 01-0000-0-1110-1000-4300-057-0000	NO REPORTING RE,MATERI	DR	5,000.00	
(001309) 01-0000-0-0000-7700-5800-057-0004	NO REPORTING RE,PROF/C	CR		5,000.00
			5,000.00	5,000.00
JE # BR22-01699 JE Trans Date 06/24/2022 JE Posted 06/24/2022 Comment BD-CAHNGE ORDER PO22-01940				
(030016) 01-7412-0-1294-3160-5800-533-0000	A-G SUCCESS,PROF/CONSL	CR		150.00
(030015) 01-7412-0-1110-1000-4399-530-0000	A-G SUCCESS,HOLDING AC	DR	150.00	
			150.00	150.00
JE # BR22-01700 JE Trans Date 06/27/2022 JE Posted 06/27/2022 Comment BL-EWR 4868 EVANS, SANDRA				
(030880) 01-3219-0-1115-3700-2230-505-0000	ELO ESSERIII LL,CLASS PUF BL-EWR 4868 EVANS, S W	CR		2,102.00
		5/31-6/30/22, EWR 44117		
(030884) 01-3219-0-1115-3700-3202-505-0000	ELO ESSERIII LL,PERS:CLAS BL-EWR 4868 EVANS, S STAT BEN,	CR		482.00
		EWR 44117		
(030885) 01-3219-0-1115-3700-3312-505-0000	ELO ESSERIII LL,FICA:CLAS BL-EWR 4868 EVANS, S STAT BEN,	CR		131.00
		EWR 44117		
(030886) 01-3219-0-1115-3700-3332-505-0000	ELO ESSERIII LL,MEDICARE BL-EWR 4868 EVANS, S STAT BEN,	CR		31.00
		EWR 44117		
(030888) 01-3219-0-1115-3700-3502-505-0000	ELO ESSERIII LL,STATE UNBL-EWR 4868 EVANS, S STAT BEN,	CR		11.00
		EWR 44117		
(030889) 01-3219-0-1115-3700-3602-505-0000	ELO ESSERIII LL,WORKERS' BL-EWR 4868 EVANS, S STAT BEN,	CR		41.00
		EWR 44117		
(030156) 01-3219-0-1115-1000-4399-505-0000	ELO ESSERIII LL,HOLDING A BL-EWR 4868 EVANS, S STAT BEN,	DR	2,798.00	
		EWR 44117		
			2,798.00	2,798.00
JE # BR22-01701 JE Trans Date 06/27/2022 JE Posted 06/27/2022 Comment BL-EWR 956 ZUNIGA MARTINEZ, MARIA PBIS INTV PLAN				
(027411) 01-7422-0-1110-1000-1130-823-0000	IPI GF,CERT SALARY:EWA,II	CR		432.00
(027411) 01-7422-0-1110-1000-1130-823-0000	IPI GF,CERT SALARY:EWA,II BL-COVER NEG	CR		2,718.00
(024641) 01-7422-0-1110-1000-1100-823-0000	IPI GF,CERT:TEACHERS S,II BL-COVER NEG	CR		112.00
(029331) 01-7422-0-1110-1000-4300-823-0000	IPI GF,MATERIALS & SUP,IN BL-COVER NEG	DR	3,262.00	
			3,262.00	3,262.00
JE # BR22-01702 JE Trans Date 06/28/2022 JE Posted 06/28/2022 Comment JL-For SpEd SS Trip				
(032168) 01-3219-0-1115-1000-5800-205-0000	ELO ESSERIII LL,PROF/CON	CR		105.00
Selection Grouped by Org, Fiscal Year, JE# - Sorted by JE Item #, (Org = 14, JE Type = R, Starting Post Date = 6/1/2022, Ending Post Date = 7/31/2022, Unposted JEs? = N, End Bud Bal? = O, JE# Page Break? = N, Description? = A, Recap? = N)				

ESCAPE ONLINE

Effective 04/14/2022 through 07/29/2022

Fiscal Year 2022

Account	Description	Comment	From	To
(continued) JE # BR22-01702 JE Trans Date 06/28/2022 JE Posted 06/28/2022	Comment JL-For SpEd SS Trip			
(030156) 01- 3219- 0- 1115- 1000- 4399- 505- 0000	ELO ESSERIII LL,HOLDING A	DR	105.00	
			105.00	105.00
JE # BR22-01703 JE Trans Date 06/29/2022 JE Posted 06/29/2022	Comment FL-REIMBURSEMENT			
(008097) 01- 9010- 0- 1110- 1000- 4300- 021- 5110	OTHER RESTRICTE,MATERI	DR	52.00	
(032182) 01- 9010- 0- 1110- 1000- 5800- 021- 5110	OTHER RESTRICTE,PROF/C	CR		52.00
			52.00	52.00
JE # BR22-01704 JE Trans Date 06/29/2022 JE Posted 06/29/2022	Comment JL-For Transportation Portable Toilets/Hand Washing			
(029721) 40- 9720- 0- 0000- 8500- 5600- 048- 0000	2012 SERIES A G,RENTAL/LI	CR		166.00
(028034) 40- 9720- 0- 0000- 8500- 6201- 048- 0000	2012 SERIES A G,NEW CON:	DR	166.00	
			166.00	166.00
JE # BR22-01705 JE Trans Date 06/29/2022 JE Posted 06/29/2022	Comment BD- TO COVER COAST PAPER INVOICES			
(001339) 01- 0000- 0- 0000- 8200- 2200- 834- 0000	NO REPORTING RE,CLASS:	DR	180.00	
(001456) 01- 0000- 0- 0000- 8200- 4300- 834- 0000	NO REPORTING RE,MATERI	CR		180.00
			180.00	180.00
JE # BR22-01706 JE Trans Date 06/29/2022 JE Posted 06/29/2022	Comment JL-Advance C/O for Res 6536			
(028166) 01- 6536- 0- 5001- 2700- 5800- 220- 0000	Sped Dispute,PROF/CONSUL	CR		9,388.00
(028168) 01- 6536- 0- 5001- 2700- 5800- 230- 0000	Sped Dispute,PROF/CONSUL	CR		27,047.00
			Net increase to Appropriations	.00
				36,435.00
JE # BR22-01707 JE Trans Date 06/29/2022 JE Posted 06/29/2022	Comment JL-Advance C/O for Res 6536			
(028166) 01- 6536- 0- 5001- 2700- 5800- 220- 0000	Sped Dispute,PROF/CONSUL	DR	9,388.00	
(028168) 01- 6536- 0- 5001- 2700- 5800- 230- 0000	Sped Dispute,PROF/CONSUL	DR	27,047.00	
			Net decrease to Appropriations	36,435.00
				.00
JE # BR22-01708 JE Trans Date 06/29/2022 JE Posted 06/29/2022	Comment BL-DU88670			
(028353) 01- 9010- 0- 0000- 7300- 4300- 058- 0553	OTHER RESTRICTE,MATERI BL-DU88670 SPROUTS MAY REPMT	CR		50.00
	CK1032			
(027199) 01- 9010- 0- 0000- 0000- 8650- 058- 0553	OTHER RESTRICTE,LEASES BL-DU88670 SPROUTS MAY REPMT	DR		50.00
	CK1032			
Selection	Grouped by Org, Fiscal Year, JE# - Sorted by JE Item #, (Org = 14, JE Type = R, Starting Post Date = 6/1/2022, Ending Post Date = 7/31/2022, Unposted JEs? = N, End Bud Bal? = O, JE# Page Break? = N, Description? = A, Recap? = N)			

ESCAPE ONLINE

Effective 04/14/2022 through 07/29/2022

Fiscal Year 2022

Account		Description	Comment	From	To
(continued)	JE # BR22-01708	JE Trans Date 06/29/2022	JE Posted 06/29/2022	Comment BL-DU88670	
(028353)	01-9010-0-0000-7300-4300-058-0553	OTHER RESTRICTE,MATERI	BL-DU88670 SPROUTS JUNE USE	CR	1,550.00
			CK1032		
(027199)	01-9010-0-0000-0000-8650-058-0553	OTHER RESTRICTE,LEASES	BL-DU88670 SPROUTS JUNE USE	DR	1,550.00
			CK1032		
(003956)	01-0723-0-0000-3600-2290-848-0000	TRANSPORT:HOME,CLASS I	BL-DU88670 CITY OF SC	CR	2,773.00
			WATERSHED ED BUS INV22-01351		
			CK272523		
(003940)	01-0723-0-0000-0000-8699-848-0000	TRANSPORT:HOME,ALL OTI	BL-DU88670 CITY OF SC	DR	2,773.00
			WATERSHED ED BUS INV22-01351		
			CK272523		
(032180)	01-9010-0-1360-1000-4300-035-0088	OTHER RESTRICTE,MATERI	BL-DU88670 SHS YEARBOOK CK184	CR	93.00
			K.BARKMAN (JUSTIN)		
(007588)	01-9010-0-0000-0000-8699-035-0088	OTHER RESTRICTE,ALL OTI	BL-DU88670 SHS YEARBOOK CK184	DR	93.00
			K.BARKMAN (JUSTIN)		
(007924)	01-9010-0-0000-8110-4300-049- FACU	OTHER RESTRICTE,MATERI	BL-DU88670 HAND DOWN MAN	CR	406.00
			DOWN CASH 7925815,1700127 USE		
(007599)	01-9010-0-0000-0000-8699-049- FACU	OTHER RESTRICTE,ALL OTI	BL-DU88670 HAND DOWN MAN	DR	406.00
			DOWN CASH 7925815,1700127 USE		
(007943)	01-9010-0-0000-8200-2290-899- FACU	OTHER RESTRICTE,CLASS I	BL-DU88670 HAND DOWN MAN	CR	94.00
			DOWN CASH 7925815,1700127 O/C		
(007626)	01-9010-0-0000-0000-8699-899- FACU	OTHER RESTRICTE,ALL OTI	BL-DU88670 HAND DOWN MAN	DR	94.00
			DOWN CASH 7925815,1700127 O/C		
(007924)	01-9010-0-0000-8110-4300-049- FACU	OTHER RESTRICTE,MATERI	BL-DU88670 SC W.POLO CK1464	CR	3,440.00
			3054252,1333675,8337926 USE		
(007599)	01-9010-0-0000-0000-8699-049- FACU	OTHER RESTRICTE,ALL OTI	BL-DU88670 SC W.POLO CK1464	DR	3,440.00
			3054252,1333675,8337926 USE		
(007924)	01-9010-0-0000-8110-4300-049- FACU	OTHER RESTRICTE,MATERI	BL-DU88670 SC W.POLO CK1463	CR	2,200.00
			6741717, 7380150 USE		
(007599)	01-9010-0-0000-0000-8699-049- FACU	OTHER RESTRICTE,ALL OTI	BL-DU88670 SC W.POLO CK1463	DR	2,200.00
			6741717, 7380150 USE		
Net increase to Appropriations				.00	21,212.00
JE # BR22-01709		JE Trans Date 06/30/2022	JE Posted 06/30/2022	Comment ST-133 Mission AC Unit Repair	
(007972)	01-9010-0-0000-8200-5600-049-0999	OTHER RESTRICTE,RENTAL		CR	58.00
(011460)	01-9010-0-0000-7600-4300-899-0999	OTHER RESTRICTE,MATERI		DR	58.00
				58.00	58.00

Selection Grouped by Org, Fiscal Year, JE# - Sorted by JE Item #, (Org = 14, JE Type = R, Starting Post Date = 6/1/2022, Ending Post Date = 7/31/2022, Unposted JEs? = N, End Bud Bal? = O, JE# Page Break? = N, Description? = A, Recap? = N)

ESCAPE ONLINE

Effective 04/14/2022 through 07/29/2022

Fiscal Year 2022

Account		Description	Comment	From	To
JE # BR22-01710		JE Trans Date 06/30/2022	JE Posted 06/30/2022	Comment BL-DU88740	
(007924)	01-9010-0-0000-8110-4300-049- FACU	OTHER RESTRICTE,MATERI	BL-DU88740 SAND-SC VOLLYBLL, 7116796 USE CK112	CR	100.00
(007599)	01-9010-0-0000-0000-8699-049- FACU	OTHER RESTRICTE,ALL OTI	BL-DU88740 SAND-SC VOLLYBLL, 7116796 CK112	DR	100.00
(007943)	01-9010-0-0000-8200-2290-899- FACU	OTHER RESTRICTE,CLASS I	BL-DU88740 SAND-SC VOLLYBL 7116796 O/C CK112	CR	47.00
(007626)	01-9010-0-0000-0000-8699-899- FACU	OTHER RESTRICTE,ALL OTI	BL-DU88740 SAND-SC VOLLYBLL 7116796 O/C CK112	DR	47.00
(007924)	01-9010-0-0000-8110-4300-049- FACU	OTHER RESTRICTE,MATERI	BL-DU88740 SC MSTRS AQ.9243440 CK1998 USE	CR	563.00
(007599)	01-9010-0-0000-0000-8699-049- FACU	OTHER RESTRICTE,ALL OTI	BL-DU88740 SC MSTRS AQUATICS 9243440 CK1998 USE	DR	563.00
(007943)	01-9010-0-0000-8200-2290-899- FACU	OTHER RESTRICTE,CLASS I	BL-DU88740 SC MSTRS AQ. 9243440 CK1998 O/C	CR	141.00
(007626)	01-9010-0-0000-0000-8699-899- FACU	OTHER RESTRICTE,ALL OTI	BL-DU88740 SC MSTRS AQUATICS 9243440 CK1998 O/C	DR	141.00
(007924)	01-9010-0-0000-8110-4300-049- FACU	OTHER RESTRICTE,MATERI	BL-DU88740 SC TENNIS 12016813,16651547,11626827 CK1513 USE	CR	780.00
(007599)	01-9010-0-0000-0000-8699-049- FACU	OTHER RESTRICTE,ALL OTI	BL-DU88740 SC TENNIS 12016813,16651547,11626827 CK1513 USE	DR	780.00
(007924)	01-9010-0-0000-8110-4300-049- FACU	OTHER RESTRICTE,MATERI	BL-DU88740 SC WPOLO CK1442 1568539,11501296 USE	CR	4,090.00
(007599)	01-9010-0-0000-0000-8699-049- FACU	OTHER RESTRICTE,ALL OTI	BL-DU88740 SC WPOLO CK1442 1568539,11501296 USE	DR	4,090.00
(007943)	01-9010-0-0000-8200-2290-899- FACU	OTHER RESTRICTE,CLASS I	BL-DU88740 SC WPOLO CK1442 1568539,11501296 O/C	CR	90.00
(007626)	01-9010-0-0000-0000-8699-899- FACU	OTHER RESTRICTE,ALL OTI	BL-DU88740 SC WPOLO CK1442 1568539,11501296 O/C	DR	90.00
(007924)	01-9010-0-0000-8110-4300-049- FACU	OTHER RESTRICTE,MATERI	BL-DU88740 SC WPOLO #1443 12871049,14636298,*4723,14922443	CR	7,890.00
(007599)	01-9010-0-0000-0000-8699-049- FACU	OTHER RESTRICTE,ALL OTI	BL-DU88740 SC WPOLO #1443 12871049,14636298,*4723,14922443	DR	7,890.00
(007924)	01-9010-0-0000-8110-4300-049- FACU	OTHER RESTRICTE,MATERI	BL-DU88740 SC WPOLO CK1441 2514618, 3427986 USE	CR	2,870.00
(007599)	01-9010-0-0000-0000-8699-049- FACU	OTHER RESTRICTE,ALL OTI	BL-DU88740 SC WPOLO CK1441 2514618, 3427986 USE	DR	2,870.00

Selection Grouped by Org, Fiscal Year, JE# - Sorted by JE Item #, (Org = 14, JE Type = R, Starting Post Date = 6/1/2022, Ending Post Date = 7/31/2022,
Unposted JEs? = N, End Bud Bal? = O, JE# Page Break? = N, Description? = A, Recap? = N)

ESCAPE ONLINE

Effective 04/14/2022 through 07/29/2022

Fiscal Year 2022

Account	Description	Comment	From	To
Net increase to Appropriations			.00	33,142.00
JE # BR22-01711 JE Trans Date 06/30/2022 JE Posted 07/05/2022 Comment JL-For Master Plan Update Contract				
(017406)	25-9010-0-0000-7200-5800-020-0000	OTHER RESTRICTE,PROF/C	CR	57,397.00
(017407)	25-9010-0-0000-7200-5800-030-0000	OTHER RESTRICTE,PROF/C	CR	104,744.00
Net increase to Appropriations			.00	162,141.00
JE # BR22-01712 JE Trans Date 06/30/2022 JE Posted 07/05/2022 Comment JD-FLYERS ENERGY INVOICE FOR GAS				
(007539)	01-8150-0-0000-8110-5600-049-0000	ONGOING & MAJOR,RENTAL JD-FLYERS ENERGY INVOICE FOR	DR	3,232.00
		GAS/COV NEG		
(007535)	01-8150-0-0000-8110-4300-049-0000	ONGOING & MAJOR,MATER JD-FLYERS ENERGY INVOICE FOR	CR	3,232.00
		GAS/COV NEG		
Net increase to Appropriations			3,232.00	3,232.00
JE # BR22-01713 JE Trans Date 06/30/2022 JE Posted 07/05/2022 Comment JL-For Miller Maxfield June Invoice				
(007911)	01-9010-0-0000-7600-5800-899-0999	OTHER RESTRICTE,PROF/C	CR	788.00
(011460)	01-9010-0-0000-7600-4300-899-0999	OTHER RESTRICTE,MATERI	DR	788.00
Net increase to Appropriations			788.00	788.00
JE # BR22-01714 JE Trans Date 06/30/2022 JE Posted 07/05/2022 Comment JL-for ESY Lead Mileage				
(032204)	01-3219-0-5760-1110-5200-205-0000	ELO ESSERIII LL,TRAVEL &	CR	11.00
(032205)	01-3219-0-5760-1110-5200-250-0000	ELO ESSERIII LL,TRAVEL &	CR	11.00
(027462)	01-3219-0-1110-1000-4399-820-0000	ELO ESSERIII LL,HOLDING A	DR	11.00
(027463)	01-3219-0-1110-1000-4399-830-0000	ELO ESSERIII LL,HOLDING A	DR	11.00
Net increase to Appropriations			22.00	22.00
JE # BR22-01715 JE Trans Date 06/30/2022 JE Posted 07/06/2022 Comment BL-COVER M.POIRIER'S CREDIT CARD YOU CAN BOOK				
(000568)	01-0000-0-0000-2700-4300-034-0000	NO REPORTING RE,MATERI	DR	87.00
(001935)	01-0000-0-1110-1000-4300-034-0000	NO REPORTING RE,MATERI	DR	21.00
(000604)	01-0000-0-0000-2700-5800-034-0000	NO REPORTING RE,PROF/C	CR	108.00
Net increase to Appropriations			108.00	108.00
JE # BR22-01716 JE Trans Date 06/30/2022 JE Posted 07/07/2022 Comment JL-For additional Mobile Modular charges for DLV portables				
(020511)	25-9010-0-0000-8700-5600-023-9121	OTHER RESTRICTE,RENTAL	CR	3,344.00

Selection Grouped by Org, Fiscal Year, JE# - Sorted by JE Item #, (Org = 14, JE Type = R, Starting Post Date = 6/1/2022, Ending Post Date = 7/31/2022, Unposted JEs? = N, End Bud Bal? = O, JE# Page Break? = N, Description? = A, Recap? = N)

ESCAPE ONLINE

Effective 04/14/2022 through 07/29/2022

Fiscal Year 2022

Account	Description	Comment	From	To
Net increase to Appropriations			.00	3,344.00
JE # BR22-01717 JE Trans Date 06/30/2022 JE Posted 07/08/2022 Comment BL-DU88864				
(007924)	01-9010-0-0000-8110-4300-049- FACU	OTHER RESTRICTE,MATERI BL-DU88864 GOV DEALS CK4365 6/7/22 INV120-0428221207-8126	CR	1,025.00
(007599)	01-9010-0-0000-0000-8699-049- FACU	OTHER RESTRICTE,ALL OTI BL-DU88864 GOV DEALS CK4365 6/7/22 INV120-0428221207-8126	DR	1,025.00
(007924)	01-9010-0-0000-8110-4300-049- FACU	OTHER RESTRICTE,MATERI BL-DU88864 MIDDLE BAY SPTS CK158 797230 USE	CR	1,000.00
(007599)	01-9010-0-0000-0000-8699-049- FACU	OTHER RESTRICTE,ALL OTI BL-DU88864 MIDDLE BAY SPTS CK158 797230 USE	DR	1,000.00
(007924)	01-9010-0-0000-8110-4300-049- FACU	OTHER RESTRICTE,MATERI BL-DU88864 NORCAL FLAG FTB CK119 5 INV USE	CR	2,894.00
(007599)	01-9010-0-0000-0000-8699-049- FACU	OTHER RESTRICTE,ALL OTI BL-DU88864 NORCAL FLAG FTB CK119 5 INV USE	DR	2,894.00
(007943)	01-9010-0-0000-8200-2290-899- FACU	OTHER RESTRICTE,CLASS I BL-DU88864 NORCAL FLAG FTB CK119 5 INV O/C	CR	1,835.00
(007626)	01-9010-0-0000-0000-8699-899- FACU	OTHER RESTRICTE,ALL OTI BL-DU88864 NORCAL FLAG FTB CK119 5 INV O/C	DR	1,835.00
(007924)	01-9010-0-0000-8110-4300-049- FACU	OTHER RESTRICTE,MATERI BL-DU88864 SC HAWKS FASTPITCH CK2130 CP CR CD, 6 INV USE	CR	380.00
(007599)	01-9010-0-0000-0000-8699-049- FACU	OTHER RESTRICTE,ALL OTI BL-DU88864 SC HAWKS FASTPITCH CK2130 CP CR CD, 6 INV USE	DR	380.00
(007924)	01-9010-0-0000-8110-4300-049- FACU	OTHER RESTRICTE,MATERI BL-DU88864 QUICKSILVER CK2130 CP CR CD, 12 INV USE	CR	17,929.00
(007599)	01-9010-0-0000-0000-8699-049- FACU	OTHER RESTRICTE,ALL OTI BL-DU88864 QUICKSILVER CK2130 CP CR CD, 12 INV USE	DR	17,929.00
(007924)	01-9010-0-0000-8110-4300-049- FACU	OTHER RESTRICTE,MATERI BL-DU88864 SC WATERPOLO CK2130 CP CR CD, 4 INV USE	CR	1,805.00
(007599)	01-9010-0-0000-0000-8699-049- FACU	OTHER RESTRICTE,ALL OTI BL-DU88864 SC WATERPOLO CK2130 CP CR CD, 4 INV USE	DR	1,805.00
(007924)	01-9010-0-0000-8110-4300-049- FACU	OTHER RESTRICTE,MATERI BL-DU88864 UCSC MENS LACROS CK2130 CP CR CD,INV 6835370 USE	CR	300.00
(007599)	01-9010-0-0000-0000-8699-049- FACU	OTHER RESTRICTE,ALL OTI BL-DU88864 UCSC MENS LACROS CK2130 CP CR CD,INV 6835370 USE	DR	300.00
(007924)	01-9010-0-0000-8110-4300-049- FACU	OTHER RESTRICTE,MATERI BL-DU88864 MIDDLE BAY SPT CK2130 CP CR CD, 12284520 USE	CR	1,600.00
(007599)	01-9010-0-0000-0000-8699-049- FACU	OTHER RESTRICTE,ALL OTI BL-DU88864 MIDDLE BAY SPT CK2130 CP CR CD, 12284520 USE	DR	1,600.00

Selection Grouped by Org, Fiscal Year, JE# - Sorted by JE Item #, (Org = 14, JE Type = R, Starting Post Date = 6/1/2022, Ending Post Date = 7/31/2022,
Unposted JEs? = N, End Bud Bal? = O, JE# Page Break? = N, Description? = A, Recap? = N)

ESCAPE ONLINE

Effective 04/14/2022 through 07/29/2022

Fiscal Year 2022

Account	Description	Comment	From	To
(continued) JE # BR22-01717 JE Trans Date 06/30/2022 JE Posted 07/08/2022 Comment BL-DU88864				
(007924) 01-9010-0-0000-8110-4300-049- FACU	OTHER RESTRICTE,MATERI	BL-DU88864 ACSC G.BKB CK2130 CP CR CD, 4 INV USE	CR	1,360.00
(007599) 01-9010-0-0000-0000-8699-049- FACU	OTHER RESTRICTE,ALL OT	BL-DU88864 ACSC G.BKB CK2130 CP CR CD, 4 INV USE	DR	1,360.00
(007943) 01-9010-0-0000-8200-2290-899- FACU	OTHER RESTRICTE,CLASS I	BL-DU88864 CAMP KESEM UCSC CK2130 CP CR CD, 3239580 O/C	CR	94.00
(007626) 01-9010-0-0000-0000-8699-899- FACU	OTHER RESTRICTE,ALL OT	BL-DU88864 CAMP KESEM UCSC CK2130 CP CR CD, 3239580 O/C	DR	94.00
(007924) 01-9010-0-0000-8110-4300-049- FACU	OTHER RESTRICTE,MATERI	BL-DU88864 MONT.BAY ADLT LACR CK2130 CP CR CD, 11116773 USE	CR	200.00
(007599) 01-9010-0-0000-0000-8699-049- FACU	OTHER RESTRICTE,ALL OT	BL-DU88864 MONT.BAY ADLT LACR CK2130 CP CR CD, 11116773 USE	DR	200.00
(007943) 01-9010-0-0000-8200-2290-899- FACU	OTHER RESTRICTE,CLASS I	BL-DU88864 ELAINE DANCE CK2130 CP CR CD,8445006 O/C	CR	188.00
(007626) 01-9010-0-0000-0000-8699-899- FACU	OTHER RESTRICTE,ALL OT	BL-DU88864 ELAINE DANCE CK2130 CP CR CD,8445006 O/C	DR	188.00
(007924) 01-9010-0-0000-8110-4300-049- FACU	OTHER RESTRICTE,MATERI	BL-DU88864 HAND DOWN M.D. CK2130 CP CR CD,16610364 USE	CR	510.00
(007599) 01-9010-0-0000-0000-8699-049- FACU	OTHER RESTRICTE,ALL OT	BL-DU88864 HAND DOWN M.D. CK2130 CP CR CD,16610364 USE	DR	510.00
(007924) 01-9010-0-0000-8110-4300-049- FACU	OTHER RESTRICTE,MATERI	BL-DU88864 EVENTSMGR CK2130 CP CR CD,4 INV USE	CR	558.00
(007599) 01-9010-0-0000-0000-8699-049- FACU	OTHER RESTRICTE,ALL OT	BL-DU88864 EVENTSMGR CK2130 CP CR CD,4 INV USE	DR	558.00
(007943) 01-9010-0-0000-8200-2290-899- FACU	OTHER RESTRICTE,CLASS I	BL-DU88864 EVENTSMGR CK2130 CP CR CD,4 INV O/C	CR	188.00
(007626) 01-9010-0-0000-0000-8699-899- FACU	OTHER RESTRICTE,ALL OT	BL-DU88864 EVENTSMGR CK2130 CP CR CD,4 INV O/C	DR	188.00
(007924) 01-9010-0-0000-8110-4300-049- FACU	OTHER RESTRICTE,MATERI	BL-DU88864 MID CNTY YTH S. CK2130 CP CR CD,6942942 USE	CR	120.00
(007599) 01-9010-0-0000-0000-8699-049- FACU	OTHER RESTRICTE,ALL OT	BL-DU88864 MID CNTY YTH S. CK2130 CP CR CD,6942942 USE	DR	120.00
(007943) 01-9010-0-0000-8200-2290-899- FACU	OTHER RESTRICTE,CLASS I	BL-DU88864 MID CNTY YTH S. CK2130 CP CR CD,6942942 O/C	CR	47.00
(007626) 01-9010-0-0000-0000-8699-899- FACU	OTHER RESTRICTE,ALL OT	BL-DU88864 MID CNTY YTH S. CK2130 CP CR CD,6942942 O/C	DR	47.00
(007924) 01-9010-0-0000-8110-4300-049- FACU	OTHER RESTRICTE,MATERI	BL-DU88864 SC LACROSSE CK2130 CP CR CD,3 INV USE	CR	255.00

Selection Grouped by Org, Fiscal Year, JE# - Sorted by JE Item #, (Org = 14, JE Type = R, Starting Post Date = 6/1/2022, Ending Post Date = 7/31/2022, Unposted JEs? = N, End Bud Bal? = O, JE# Page Break? = N, Description? = A, Recap? = N)

ESCAPE ONLINE

Effective 04/14/2022 through 07/29/2022

Fiscal Year 2022

Account	Description	Comment	From	To
(continued) JE # BR22-01717 JE Trans Date 06/30/2022 JE Posted 07/08/2022 Comment BL-DU88864				
(007599) 01-9010-0-0000-0000-8699-049- FACU	OTHER RESTRICTE,ALL OTI	BL-DU88864 SC LACROSSE CK2130 CP CR CD,3 INV USE	DR	255.00
(007924) 01-9010-0-0000-8110-4300-049- FACU	OTHER RESTRICTE,MATERI	BL-DU88864 ADULT FUTSAL CK2130 CP CR CD,7989849 USE	CR	300.00
(007599) 01-9010-0-0000-0000-8699-049- FACU	OTHER RESTRICTE,ALL OTI	BL-DU88864 ADULT FUTSAL CK2130 CP CR CD,7989849 USE	DR	300.00
Net increase to Appropriations			.00	65,176.00

Account	Description	Comment	From	To
JE # BR22-01718 JE Trans Date 06/30/2022 JE Posted 07/08/2022 Comment DU88864				
(007924) 01-9010-0-0000-8110-4300-049- FACU	OTHER RESTRICTE,MATERI	DU88864 LIVE LIKE GENO CP CK2130 CR CD, 2129532/10969911 USE	CR	2,887.00
(007599) 01-9010-0-0000-0000-8699-049- FACU	OTHER RESTRICTE,ALL OTI	DU88864 LIVE LIKE GENO CP CK2130 CR CD, 2129532/10969911 USE	DR	2,887.00
(007924) 01-9010-0-0000-8110-4300-049- FACU	OTHER RESTRICTE,MATERI	DU88864 MENS SR BSBL CP CK2130 CR CD, 11969136 USE	CR	200.00
(007599) 01-9010-0-0000-0000-8699-049- FACU	OTHER RESTRICTE,ALL OTI	DU88864 MENS SR BSBL CP CK2130 CR CD, 11969136 USE	DR	200.00
(007924) 01-9010-0-0000-8110-4300-049- FACU	OTHER RESTRICTE,MATERI	DU88864 UC MENS RUGBY CP CK2130 CR CD, 11044823 USE	CR	210.00
(007599) 01-9010-0-0000-0000-8699-049- FACU	OTHER RESTRICTE,ALL OTI	DU88864 UC MENS RUGBY CP CK2130 CR CD, 11044823 USE	DR	210.00
(007924) 01-9010-0-0000-8110-4300-049- FACU	OTHER RESTRICTE,MATERI	DU88864 UCSC WOMENS CLUB SOCC CP CK2130 CR CD, 5274850 USE	CR	200.00
(007599) 01-9010-0-0000-0000-8699-049- FACU	OTHER RESTRICTE,ALL OTI	DU88864 UCSC WOMENS CLUB SOCC CP CK2130 CR CD, 5274850 USE	DR	200.00
(007943) 01-9010-0-0000-8200-2290-899- FACU	OTHER RESTRICTE,CLASS I	DU88864 UCSC WOMENS CLUB SOCC CP CK2130 CR CD, 5274850 USE	CR	47.00
(007626) 01-9010-0-0000-0000-8699-899- FACU	OTHER RESTRICTE,ALL OTI	DU88864 UCSC WOMENS CLUB SOCC CP CK2130 CR CD, 5274850 USE	DR	47.00
Net increase to Appropriations			.00	7,088.00

Selection Grouped by Org, Fiscal Year, JE# - Sorted by JE Item #, (Org = 14, JE Type = R, Starting Post Date = 6/1/2022, Ending Post Date = 7/31/2022, Unposted JEs? = N, End Bud Bal? = O, JE# Page Break? = N, Description? = A, Recap? = N)

ESCAPE ONLINE

Page 43 of 88

Effective 04/14/2022 through 07/29/2022

Fiscal Year 2022

Account	Description	Comment	From	To
JE # BR22-01719 JE Trans Date 06/30/2022 JE Posted 07/08/2022 Comment JL-Add funds for Greenbacker PO				
(020379) 01- 0000- 0- 0000- 8200- 5513- 899- 0000	NO REPORTING RE,ELECTR	CR		5,502.00
(001465) 01- 0000- 0- 0000- 8200- 5511- 899- 0000	NO REPORTING RE,GAS & E	DR	1,511.00	
(001470) 01- 0000- 0- 0000- 8200- 5523- 899- 0000	NO REPORTING RE,GARBA	DR	949.00	
(001461) 01- 0000- 0- 0000- 8200- 4300- 899- 0000	NO REPORTING RE,MATERI	DR	3,042.00	
			5,502.00	5,502.00
JE # BR22-01720 JE Trans Date 06/30/2022 JE Posted 07/08/2022 Comment SK-ABRITE INVOICES/ESY BOWLING				
(006671) 01- 6500- 0- 5760- 1180- 5100- 230- 0000	SE:STATE LOCAL ,SUBAGRI SK-ABRITE INVOICES	CR		65,806.00
(006674) 01- 6500- 0- 5760- 1180- 5800- 230- 0000	SE:STATE LOCAL ,PROF/CO SK-ABRITE INVOICES	DR	65,806.00	
(032168) 01- 3219- 0- 1115- 1000- 5800- 205- 0000	ELO ESSERIII LL,PROF/CON SK-ESY BOWLING	CR		105.00
(031659) 01- 3219- 0- 5760- 1110- 3101- 205- 0000	ELO ESSERIII LL,STRS:CER` SK-ESY BOWLING	DR	105.00	
			65,911.00	65,911.00
JE # BR22-01721 JE Trans Date 06/30/2022 JE Posted 07/11/2022 Comment TH-R22-02685				
(032209) 21- 9734- 0- 0000- 8500- 5600- 023- B012	Bond A Elem,RENTAL/LEASE	CR		1,680.00
(010424) 21- 9734- 0- 0000- 8500- 6200- 000- 0000	BOND A ELEM,BUILDINGS &	DR	1,680.00	
			1,680.00	1,680.00
JE # BR22-01722 JE Trans Date 06/30/2022 JE Posted 07/11/2022 Comment JD - CENTRAL COAST SYSTEMS, INVOICES				
(007543) 01- 8150- 0- 0000- 8110- 6500- 049- 0000	ONGOING & MAJOR,EQUIPM	DR	15,595.00	
(007540) 01- 8150- 0- 0000- 8110- 5800- 049- 0000	ONGOING & MAJOR,PROF/C	CR		15,595.00
			15,595.00	15,595.00
JE # BR22-01723 JE Trans Date 06/30/2022 JE Posted 07/11/2022 Comment JD - FLYERS ENERGY (GAS), HOME DEPOT, INVOICES				
(007543) 01- 8150- 0- 0000- 8110- 6500- 049- 0000	ONGOING & MAJOR,EQUIPM	DR	7,010.00	
(007535) 01- 8150- 0- 0000- 8110- 4300- 049- 0000	ONGOING & MAJOR,MATER	CR		7,010.00
			7,010.00	7,010.00
JE # BR22-01724 JE Trans Date 06/30/2022 JE Posted 07/12/2022 Comment JL-Decrease budgets will be used in FY 22/23				
(029721) 40- 9720- 0- 0000- 8500- 5600- 048- 0000	2012 SERIES A G,RENTAL/LI	DR	3,119.00	
(028034) 40- 9720- 0- 0000- 8500- 6201- 048- 0000	2012 SERIES A G,NEW CON:	DR	95,550.00	
(028442) 40- 9720- 0- 0000- 8500- 6202- 048- 0000	2012 SERIES A G,MODERNIZ	DR	3,563.00	
(026154) 40- 9720- 0- 0000- 8500- 6210- 048- 0000	2012 SERIES A G,ARCHITEC	DR	48,819.00	

Selection Grouped by Org, Fiscal Year, JE# - Sorted by JE Item #, (Org = 14, JE Type = R, Starting Post Date = 6/1/2022, Ending Post Date = 7/31/2022, Unposted JEs? = N, End Bud Bal? = O, JE# Page Break? = N, Description? = A, Recap? = N)

ESCAPE ONLINE

Effective 04/14/2022 through 07/29/2022

Fiscal Year 2022

Account	Description	Comment	From	To
(continued)	JE # BR22-01724 JE Trans Date 06/30/2022 JE Posted 07/12/2022	Comment JL-Decrease budgets will be used in FY 22/23		
(027926) 40- 9720- 0- 0000- 8500- 6220- 048- 0000	2012 SERIES A G,DSA PLAN	DR	10,004.00	
(026155) 40- 9720- 0- 0000- 8500- 6251- 048- 0000	2012 SERIES A G,REIMBURSE	DR	1,578.00	
(027890) 40- 9720- 0- 0000- 8500- 6290- 048- 0000	2012 SERIES A G,INSPECT	DR	15,750.00	
Net decrease to Appropriations			178,383.00	.00
	JE # BR22-01725 JE Trans Date 06/30/2022 JE Posted 07/12/2022	Comment AR - Cover DLV Yard Duty		
(027462) 01- 3219- 0- 1110- 1000- 4399- 820- 0000	ELO ESSERIII LL,HOLDING A	DR	129.00	
(030575) 01- 3219- 0- 0000- 8300- 2930- 823- 0000	ELO ESSERIII LL,OTHER CL	CR		115.00
(030580) 01- 3219- 0- 0000- 8300- 3312- 823- 0000	ELO ESSERIII LL,FICA:CLAS	CR		8.00
(030581) 01- 3219- 0- 0000- 8300- 3332- 823- 0000	ELO ESSERIII LL,MEDICARE	CR		2.00
(030583) 01- 3219- 0- 0000- 8300- 3502- 823- 0000	ELO ESSERIII LL,STATE UNE	CR		1.00
(030584) 01- 3219- 0- 0000- 8300- 3602- 823- 0000	ELO ESSERIII LL,WORKERS'	CR		3.00
Net decrease to Appropriations			129.00	129.00
	JE # BR22-01726 JE Trans Date 06/30/2022 JE Posted 07/12/2022	Comment WM-PAYMENT FOR EDCAL PRINT AD INVOICES		
(001212) 01- 0000- 0- 0000- 7400- 4395- 854- 0000	NO REPORTING RE,FOOD F	DR	1,723.00	
(001225) 01- 0000- 0- 0000- 7400- 5800- 854- 0000	NO REPORTING RE,PROF/C	CR		1,723.00
Net decrease to Appropriations			1,723.00	1,723.00
	JE # BR22-01727 JE Trans Date 06/30/2022 JE Posted 07/12/2022	Comment JL-Decrease Budgets for District Set Aside move to 22/23		
(026911) 40- 9720- 0- 0000- 8500- 6200- 020- 0000	2012 SERIES A G,BUILDING	DR	22,643.00	
(028080) 40- 9720- 0- 0000- 8500- 6202- 020- 0000	2012 SERIES A G,MODERNIZ	DR	7,160.00	
(028082) 40- 9720- 0- 0000- 8500- 6210- 020- 0000	2012 SERIES A G,ARCHITEC	DR	520.00	
(028081) 40- 9720- 0- 0000- 8500- 6220- 020- 0000	2012 SERIES A G,DSA PLAN	DR	2,739.00	
(028083) 40- 9720- 0- 0000- 8500- 6251- 020- 0000	2012 SERIES A G,REIMBURSE	DR	42.00	
Net decrease to Appropriations			33,104.00	.00
	JE # BR22-01728 JE Trans Date 06/30/2022 JE Posted 07/12/2022	Comment JL-Decrease District Wide for Food Service move to 22/23		
(029631) 40- 9720- 0- 0000- 8500- 6200- 046- 0000	2012 SERIES A G,BUILDING	DR	622,947.00	
(031124) 40- 9720- 0- 0000- 8500- 6210- 046- 0000	2012 SERIES A G,ARCHITEC	DR	19.00	
(029754) 40- 9720- 0- 0000- 8500- 6500- 046- 0000	2012 SERIES A G,EQUIPMEN	DR	13,752.00	
Net decrease to Appropriations			636,718.00	.00

Selection Grouped by Org, Fiscal Year, JE# - Sorted by JE Item #, (Org = 14, JE Type = R, Starting Post Date = 6/1/2022, Ending Post Date = 7/31/2022, Unposted JEs? = N, End Bud Bal? = O, JE# Page Break? = N, Description? = A, Recap? = N)

ESCAPE ONLINE

Effective 04/14/2022 through 07/29/2022

Fiscal Year 2022

Account	Description	Comment	From	To
JE # BR22-01729 JE Trans Date 06/30/2022 JE Posted 07/12/2022 Comment JL-Decrease District Set Aside move to 22/23				
(026911) 40-9720-0-0000-8500-6200-020-0000	2012 SERIES A G,BUILDING	DR	11,860.00	
(028082) 40-9720-0-0000-8500-6210-020-0000	2012 SERIES A G,ARCHITEC	DR	20,916.00	
(028083) 40-9720-0-0000-8500-6251-020-0000	2012 SERIES A G,REIMBUR	DR	755.00	
Net decrease to Appropriations			33,531.00	.00
JE # BR22-01730 JE Trans Date 06/30/2022 JE Posted 07/12/2022 Comment JL-Increase budget for AMS.Net PO				
(031021) 25-9010-0-0000-8500-6260-020-0000	OTHER RESTRICTE,IT INFE	CR		15,832.00
(031022) 25-9010-0-0000-8500-6260-030-0000	OTHER RESTRICTE,IT INFE	CR		10,960.00
Net increase to Appropriations			.00	26,792.00
JE # BR22-01731 JE Trans Date 06/30/2022 JE Posted 07/12/2022 Comment JL-To Cover PO22-00001				
(001301) 01-0000-0-0000-7700-4300-057-0000	NO REPORTING RE,MATERI	CR		567.00
(001307) 01-0000-0-0000-7700-5300-057-0000	NO REPORTING RE,DUES &	DR	450.00	
(001306) 01-0000-0-0000-7700-5200-057-0000	NO REPORTING RE,TRAVEL	DR	117.00	
Net increase to Appropriations			567.00	567.00
JE # BR22-01732 JE Trans Date 06/30/2022 JE Posted 07/12/2022 Comment JL-Decrease District Set Aside move to FY 22/23				
(029632) 40-9720-0-0000-8500-6200-049-0000	2012 SERIES A G,BUILDING	DR	69,120.00	
(030829) 40-9720-0-0000-8500-6202-049-0000	2012 SERIES A G,MODERNIZ	DR	33,768.00	
Net decrease to Appropriations			102,888.00	.00
JE # BR22-01733 JE Trans Date 06/30/2022 JE Posted 07/12/2022 Comment JL-Decrease District Set Aside Transportation move to 22/23				
(028034) 40-9720-0-0000-8500-6201-048-0000	2012 SERIES A G,NEW CON	DR	150,822.00	
(027890) 40-9720-0-0000-8500-6290-048-0000	2012 SERIES A G,INSPECT	DR	2,657.00	
Net decrease to Appropriations			153,479.00	.00
JE # BR22-01734 JE Trans Date 06/30/2022 JE Posted 07/12/2022 Comment JL-For Replacement books for BSS				
(032053) 01-0000-0-3100-2420-4200-838-0004	NO REPORTING RE,BOOKS	CR		352.00
(002800) 01-0000-0-3100-3110-3401-838-0000	NO REPORTING RE,HEALTH	DR	352.00	
Net increase to Appropriations			352.00	352.00
JE # BR22-01735 JE Trans Date 06/30/2022 JE Posted 07/13/2022 Comment AR - Cover IT DGI Invoice				
(001305) 01-0000-0-0000-7700-4400-857-0000	NO REPORTING RE,NON-CA	DR	4,602.00	

Selection Grouped by Org, Fiscal Year, JE# - Sorted by JE Item #, (Org = 14, JE Type = R, Starting Post Date = 6/1/2022, Ending Post Date = 7/31/2022, Unposted JEs? = N, End Bud Bal? = O, JE# Page Break? = N, Description? = A, Recap? = N)

ESCAPE ONLINE

Effective 04/14/2022 through 07/29/2022

Fiscal Year 2022

Account	Description	Comment	From	To
(continued) JE # BR22-01735 JE Trans Date 06/30/2022 JE Posted 07/13/2022	Comment AR - Cover IT DGI Invoice			
(001311) 01-0000-0-0000-7700-5800-857-0000	NO REPORTING RE,PROF/C	CR		4,602.00
			4,602.00	4,602.00
JE # BR22-01736 JE Trans Date 06/30/2022 JE Posted 07/13/2022	Comment SK-ABRITE BEHAVIOR SUPPORT			
(029629) 01-6537-0-5760-1190-5100-220-0000	Sped Learn Rec,SUBAGREEN	CR		2,464.00
(028174) 01-6537-0-5760-1110-4300-220-0000	Sped Learn Rec,MATERIALS	DR	2,464.00	
			2,464.00	2,464.00
JE # BR22-01737 JE Trans Date 06/30/2022 JE Posted 07/13/2022	Comment JL-Decrease District Set Aside move to FY 22/23			
(030829) 40-9720-0-0000-8500-6202-049-0000	2012 SERIES A G,MODERNIZ	DR	5,617.00	
			5,617.00	.00
JE # BR22-01738 JE Trans Date 06/30/2022 JE Posted 07/14/2022	Comment BL-DU89008			
(007924) 01-9010-0-0000-8110-4300-049-FACU	OTHER RESTRICTE,MATERI BL-DU89008 SC MSTR AQUATICS	CR		563.00
	CK2000 USE 1287043			
(007599) 01-9010-0-0000-0000-8699-049-FACU	OTHER RESTRICTE,ALL OTI BL-DU89008 SC MSTR AQUATICS	DR		563.00
	CK2000 USE AR220035			
(007943) 01-9010-0-0000-8200-2290-899-FACU	OTHER RESTRICTE,CLASS I BL-DU89008 SC MSTR AQUATICS	CR		94.00
	CK2000 O/C 1287043			
(007626) 01-9010-0-0000-0000-8699-899-FACU	OTHER RESTRICTE,ALL OTI BL-DU89008 SC MSTR AQUATICS	DR		94.00
	CK2000 O/C AR220036			
(007924) 01-9010-0-0000-8110-4300-049-FACU	OTHER RESTRICTE,MATERI BL-DU89008 SC MSTR AQUATICS	CR		891.00
	CK2004 USE 5109570			
(007599) 01-9010-0-0000-0000-8699-049-FACU	OTHER RESTRICTE,ALL OTI BL-DU89008 SC MSTR AQUATICS	DR		891.00
	CK2004 USE AR220035			
			.00	3,096.00
JE # BR22-01739 JE Trans Date 06/30/2022 JE Posted 07/15/2022	Comment BL-FOR LEASE BLDG REMOVAL AT DLV 3 OF 3			
(020511) 25-9010-0-0000-8700-5600-023-9121	OTHER RESTRICTE,RENTAL	CR		12,276.00
			.00	12,276.00
JE # BR22-01740 JE Trans Date 06/30/2022 JE Posted 07/15/2022	Comment JL-Decrease site supplie budgets moving to FY 22/23			
(031367) 01-6053-0-1110-1000-4300-521-0000	UNIV PRE-K PLAN,MATERIA	DR	20,000.00	
(031368) 01-6053-0-1110-1000-4300-523-0000	UNIV PRE-K PLAN,MATERIA	DR	20,000.00	
Selection	Grouped by Org, Fiscal Year, JE# - Sorted by JE Item #, (Org = 14, JE Type = R, Starting Post Date = 6/1/2022, Ending Post Date = 7/31/2022, Unposted JEs? = N, End Bud Bal? = O, JE# Page Break? = N, Description? = A, Recap? = N)			

ESCAPE ONLINE

Effective 04/14/2022 through 07/29/2022

Fiscal Year 2022

Account	Description	Comment	From	To
(continued) JE # BR22-01740 JE Trans Date 06/30/2022 JE Posted 07/15/2022		Comment JL-Decrease site supplie budgets moving to FY 22/23		
(031369) 01- 6053- 0- 1110- 1000- 4300- 524- 0000	UNIV PRE-K PLAN,MATERIA	DR	20,000.00	
(031370) 01- 6053- 0- 1110- 1000- 4300- 527- 0000	UNIV PRE-K PLAN,MATERIA	DR	20,000.00	
(031371) 01- 6053- 0- 1110- 1000- 4399- 520- 0000	UNIV PRE-K PLAN,HOLDING	DR	58,555.00	
(031373) 01- 6053- 0- 0000- 7210- 7310- 520- 0000	UNIV PRE-K PLAN,XFER:IND	DR	8,175.00	
Net decrease to Appropriations			146,730.00	.00

JE # BR22-01741 JE Trans Date 04/14/2022 JE Posted 07/15/2022	Comment BL-DU86816 SCCOE MH CUL REV BGT INCR INV22-01317
(027811) 01- 9010- 0- 0000- 7300- 4300- 058- 0554	OTHER RESTRICTE,MATERI DR 1,500.00
(027810) 01- 9010- 0- 0000- 0000- 8650- 058- 0554	OTHER RESTRICTE,LEASES CR 1,500.00
Net decrease to Appropriations	
3,000.00 .00	

JE # BR22-01742 JE Trans Date 06/16/2022 JE Posted 07/15/2022	Comment BL-SCCOE 313 SWIFT INCR BUDGET
(027812) 01- 9010- 0- 0000- 0000- 8650- 058- 0555	OTHER RESTRICTE,LEASES DR 3,538.00
Net increase to Appropriations	
.00 3,538.00	

JE # BR22-01743 JE Trans Date 06/30/2022 JE Posted 07/15/2022	Comment BL-REVISE BGT YEAR END
(009367) 11- 0831- 0- 0000- 0000- 8699- 040- 0000	ADULT ED APPORT,ALL OTI BL-REVISE BGT YEAR END UTILITIES CR 1,787.00
Net decrease to Appropriations	
1,787.00 .00	

JE # BR22-01744 JE Trans Date 06/30/2022 JE Posted 07/19/2022	Comment BL-3rd interim BV
(026905) 01- 0000- 0- 0000- 2495- 2230- 821- 0000	NO REPORTING RE,CLASS I BL-EFY BV DR 1,559.00
(011787) 01- 0000- 0- 0000- 2700- 1340- 821- 0000	NO REPORTING RE,CERT S CR 3,150.00
(000359) 01- 0000- 0- 0000- 2700- 2400- 821- 0000	NO REPORTING RE,CLERIC, DR 3,652.00
(000381) 01- 0000- 0- 0000- 2700- 2440- 821- 0000	NO REPORTING RE,CLASS (DR 706.00
(000396) 01- 0000- 0- 0000- 2700- 3101- 821- 0000	NO REPORTING RE,STRS:C DR 664.00
(000412) 01- 0000- 0- 0000- 2700- 3202- 821- 0000	NO REPORTING RE,PERS:C CR 603.00
(000430) 01- 0000- 0- 0000- 2700- 3312- 821- 0000	NO REPORTING RE,FICA:CL DR 398.00
(000447) 01- 0000- 0- 0000- 2700- 3331- 821- 0000	NO REPORTING RE,MEDICA CR 88.00
(000461) 01- 0000- 0- 0000- 2700- 3332- 821- 0000	NO REPORTING RE,MEDICA DR 92.00
(000500) 01- 0000- 0- 0000- 2700- 3501- 821- 0000	NO REPORTING RE,STATE U CR 31.00
(000514) 01- 0000- 0- 0000- 2700- 3502- 821- 0000	NO REPORTING RE,STATE U DR 49.00
(000530) 01- 0000- 0- 0000- 2700- 3601- 821- 0000	NO REPORTING RE,WORKE CR 115.00
(000544) 01- 0000- 0- 0000- 2700- 3602- 821- 0000	NO REPORTING RE,WORKE DR 123.00
(000889) 01- 0000- 0- 0000- 3140- 2200- 821- 0000	NO REPORTING RE,CLASS: DR 2,790.00

Selection Grouped by Org, Fiscal Year, JE# - Sorted by JE Item #, (Org = 14, JE Type = R, Starting Post Date = 6/1/2022, Ending Post Date = 7/31/2022, Unposted JEs? = N, End Bud Bal? = O, JE# Page Break? = N, Description? = A, Recap? = N)

ESCAPE ONLINE

Effective 04/14/2022 through 07/29/2022

Fiscal Year 2022

Account		Description	Comment	From	To
(continued)	JE # BR22-01744	JE Trans Date 06/30/2022	JE Posted 07/19/2022	Comment BL-3rd interim BV	
(000902)	01-0000-0-0000-3140-2230-821-0000	NO REPORTING RE,CLASS I	DR	379.00	
(000926)	01-0000-0-0000-3140-3312-821-0000	NO REPORTING RE,FICA:CL	CR		111.00
(000941)	01-0000-0-0000-3140-3332-821-0000	NO REPORTING RE,MEDICA	CR		26.00
(000961)	01-0000-0-0000-3140-3502-821-0000	NO REPORTING RE,STATE U	CR		9.00
(000975)	01-0000-0-0000-3140-3602-821-0000	NO REPORTING RE,WORKE	CR		34.00
(027978)	01-0000-0-0000-3160-3312-821-0000	NO REPORTING RE,FICA:CL	DR	35.00	
(027979)	01-0000-0-0000-3160-3332-821-0000	NO REPORTING RE,MEDICA	DR	9.00	
(027981)	01-0000-0-0000-3160-3502-821-0000	NO REPORTING RE,STATE U	DR	2.00	
(027982)	01-0000-0-0000-3160-3602-821-0000	NO REPORTING RE,WORKE	DR	11.00	
(001332)	01-0000-0-0000-8200-2200-821-0000	NO REPORTING RE,CLASS:I	CR		1,493.00
(001349)	01-0000-0-0000-8200-2240-821-0000	NO REPORTING RE,CLASS I	DR	2,219.00	
(001366)	01-0000-0-0000-8200-3202-821-0000	NO REPORTING RE,PERS:C	CR		484.00
(001379)	01-0000-0-0000-8200-3312-821-0000	NO REPORTING RE,FICA:CL	CR		381.00
(001392)	01-0000-0-0000-8200-3332-821-0000	NO REPORTING RE,MEDICA	CR		89.00
(001405)	01-0000-0-0000-8200-3402-821-0000	NO REPORTING RE,HEALTH	DR	10,283.00	
(001417)	01-0000-0-0000-8200-3502-821-0000	NO REPORTING RE,STATE U	CR		15.00
(001430)	01-0000-0-0000-8200-3602-821-0000	NO REPORTING RE,WORKE	CR		91.00
(001449)	01-0000-0-0000-8200-4300-821-0000	NO REPORTING RE,MATERI	DR	805.00	
(001493)	01-0000-0-0000-8300-2900-821-0000	NO REPORTING RE,CLASS:(DR	187.00	
(001502)	01-0000-0-0000-8300-2940-821-0000	NO REPORTING RE,OTHER	DR	152.00	
(001514)	01-0000-0-0000-8300-3312-821-0000	NO REPORTING RE,FICA:CL	CR		5.00
(001527)	01-0000-0-0000-8300-3332-821-0000	NO REPORTING RE,MEDICA	CR		2.00
(001549)	01-0000-0-0000-8300-3502-821-0000	NO REPORTING RE,STATE U	CR		1.00
(001561)	01-0000-0-0000-8300-3602-821-0000	NO REPORTING RE,WORKE	CR		1.00
(001591)	01-0000-0-1110-1000-1100-821-0000	NO REPORTING RE,CERT:TI	DR	24,644.00	
(001620)	01-0000-0-1110-1000-1140-821-0000	NO REPORTING RE,CERT S.	CR		16,785.00
(001657)	01-0000-0-1110-1000-2100-821-0000	NO REPORTING RE,CLASS:I	DR	3,646.00	
(028445)	01-0000-0-1110-1000-2140-821-0000	NO REPORTING RE,CLASS I	CR		4,656.00
(001684)	01-0000-0-1110-1000-3101-821-0000	NO REPORTING RE,STRS:C	DR	3,492.00	
(001720)	01-0000-0-1110-1000-3202-821-0000	NO REPORTING RE,PERS:C	DR	5,014.00	
(001733)	01-0000-0-1110-1000-3311-821-0000	NO REPORTING RE,FICA:CE	CR		253.00
(001752)	01-0000-0-1110-1000-3312-821-0000	NO REPORTING RE,FICA:CL	DR	45.00	
(001772)	01-0000-0-1110-1000-3331-821-0000	NO REPORTING RE,MEDICA	DR	1,106.00	
(001801)	01-0000-0-1110-1000-3332-821-0000	NO REPORTING RE,MEDICA	DR	9.00	
(014675)	01-0000-0-1110-1000-3402-821-0000	NO REPORTING RE,HEALTH	DR	1,993.00	
(001831)	01-0000-0-1110-1000-3501-821-0000	NO REPORTING RE,STATE U	DR	389.00	
(001860)	01-0000-0-1110-1000-3502-821-0000	NO REPORTING RE,STATE U	DR	3.00	

Selection Grouped by Org, Fiscal Year, JE# - Sorted by JE Item #, (Org = 14, JE Type = R, Starting Post Date = 6/1/2022, Ending Post Date = 7/31/2022, Unposted JEs? = N, End Bud Bal? = O, JE# Page Break? = N, Description? = A, Recap? = N)

ESCAPE ONLINE

Effective 04/14/2022 through 07/29/2022

Fiscal Year 2022

Account	Description	Comment	From	To
(continued) JE # BR22-01744 JE Trans Date 06/30/2022 JE Posted 07/19/2022		Comment BL-3rd interim BV		
(001879) 01-0000-0-1110-1000-3601-821-0000	NO REPORTING RE,WORKE	DR	1,491.00	
(001908) 01-0000-0-1110-1000-3602-821-0000	NO REPORTING RE,WORKE	DR	13.00	
Net decrease to Appropriations			65,960.00	28,423.00

JE # BR22-01745 JE Trans Date 06/30/2022 JE Posted 07/19/2022	Description	Comment	From	To
		Comment BL-3rd interim DLV		
(000360) 01-0000-0-0000-2700-2400-823-0000	NO REPORTING RE,CLERIC.	DR	5,962.00	
(017411) 01-0000-0-0000-2700-2430-823-0000	NO REPORTING RE,CLASS (DR	5,379.00	
(000382) 01-0000-0-0000-2700-2440-823-0000	NO REPORTING RE,CLASS (CR		744.00
(000397) 01-0000-0-0000-2700-3101-823-0000	NO REPORTING RE,STRS:C	CR		1.00
(000413) 01-0000-0-0000-2700-3202-823-0000	NO REPORTING RE,PERS:C	DR	84.00	
(000431) 01-0000-0-0000-2700-3312-823-0000	NO REPORTING RE,FICA:CL	DR	135.00	
(000448) 01-0000-0-0000-2700-3331-823-0000	NO REPORTING RE,MEDICA	DR	173.00	
(000462) 01-0000-0-0000-2700-3332-823-0000	NO REPORTING RE,MEDICA	CR		36.00
(000479) 01-0000-0-0000-2700-3401-823-0000	NO REPORTING RE,HEALTH	DR	6.00	
(000501) 01-0000-0-0000-2700-3501-823-0000	NO REPORTING RE,STATE U	DR	60.00	
(000515) 01-0000-0-0000-2700-3502-823-0000	NO REPORTING RE,STATE U	CR		12.00
(000531) 01-0000-0-0000-2700-3601-823-0000	NO REPORTING RE,WORKE	DR	230.00	
(000545) 01-0000-0-0000-2700-3602-823-0000	NO REPORTING RE,WORKE	CR		48.00
(000890) 01-0000-0-0000-3140-2200-823-0000	NO REPORTING RE,CLASS:S	DR	659.00	
(011894) 01-0000-0-0000-3140-3202-823-0000	NO REPORTING RE,PERS:C	DR	1,572.00	
(000927) 01-0000-0-0000-3140-3312-823-0000	NO REPORTING RE,FICA:CL	DR	2.00	
(000962) 01-0000-0-0000-3140-3502-823-0000	NO REPORTING RE,STATE U	CR		1.00
(001333) 01-0000-0-0000-8200-2200-823-0000	NO REPORTING RE,CLASS:S	DR	24,659.00	
(001345) 01-0000-0-0000-8200-2230-823-0000	NO REPORTING RE,CLASS F	DR	6,021.00	
(001350) 01-0000-0-0000-8200-2240-823-0000	NO REPORTING RE,CLASS F	CR		2,819.00
(001367) 01-0000-0-0000-8200-3202-823-0000	NO REPORTING RE,PERS:C	DR	5,162.00	
(001380) 01-0000-0-0000-8200-3312-823-0000	NO REPORTING RE,FICA:CL	DR	2,220.00	
(001393) 01-0000-0-0000-8200-3332-823-0000	NO REPORTING RE,MEDICA	DR	553.00	
(001406) 01-0000-0-0000-8200-3402-823-0000	NO REPORTING RE,HEALTH	DR	7,891.00	
(001418) 01-0000-0-0000-8200-3502-823-0000	NO REPORTING RE,STATE U	DR	180.00	
(001431) 01-0000-0-0000-8200-3602-823-0000	NO REPORTING RE,WORKE	DR	703.00	
(001450) 01-0000-0-0000-8200-4300-823-0000	NO REPORTING RE,MATERI	DR	30.00	
(001494) 01-0000-0-0000-8300-2900-823-0000	NO REPORTING RE,CLASS:(DR	4,149.00	
(001498) 01-0000-0-0000-8300-2930-823-0000	NO REPORTING RE,OTHER	DR	976.00	
(013747) 01-0000-0-0000-8300-2940-823-0000	NO REPORTING RE,OTHER	CR		2,816.00
(001504) 01-0000-0-0000-8300-3202-823-0000	NO REPORTING RE,PERS:C	CR		538.00
(001515) 01-0000-0-0000-8300-3312-823-0000	NO REPORTING RE,FICA:CL	DR	485.00	

Selection Grouped by Org, Fiscal Year, JE# - Sorted by JE Item #, (Org = 14, JE Type = R, Starting Post Date = 6/1/2022, Ending Post Date = 7/31/2022, Unposted JEs? = N, End Bud Bal? = O, JE# Page Break? = N, Description? = A, Recap? = N)

ESCAPE ONLINE

Effective 04/14/2022 through 07/29/2022

Fiscal Year 2022

Account	Description	Comment	From	To
(continued) JE # BR22-01745 JE Trans Date 06/30/2022 JE Posted 07/19/2022		Comment BL-3rd interim DLV		
(001528) 01-0000-0-0000-8300-3332-823-0000	NO REPORTING RE,MEDICA	DR	114.00	
(001550) 01-0000-0-0000-8300-3502-823-0000	NO REPORTING RE,STATE U	DR	40.00	
(001562) 01-0000-0-0000-8300-3602-823-0000	NO REPORTING RE,WORKE	DR	155.00	
(001592) 01-0000-0-1110-1000-1100-823-0000	NO REPORTING RE,CERT:TI	CR		8,231.00
(001621) 01-0000-0-1110-1000-1140-823-0000	NO REPORTING RE,CERT S.	DR	5,955.00	
(001658) 01-0000-0-1110-1000-2100-823-0000	NO REPORTING RE,CLASS:I	DR	548.00	
(001664) 01-0000-0-1110-1000-2130-823-0000	NO REPORTING RE,CLASS I	DR	387.00	
(001685) 01-0000-0-1110-1000-3101-823-0000	NO REPORTING RE,STRS:C	DR	4,545.00	
(001721) 01-0000-0-1110-1000-3202-823-0000	NO REPORTING RE,PERS:C	CR		183.00
(001734) 01-0000-0-1110-1000-3311-823-0000	NO REPORTING RE,FICA:CE	CR		119.00
(001753) 01-0000-0-1110-1000-3312-823-0000	NO REPORTING RE,FICA:CL	CR		21.00
(001773) 01-0000-0-1110-1000-3331-823-0000	NO REPORTING RE,MEDICA	DR	1,701.00	
(001802) 01-0000-0-1110-1000-3332-823-0000	NO REPORTING RE,MEDICA	CR		5.00
(001810) 01-0000-0-1110-1000-3401-823-0000	NO REPORTING RE,HEALTH	CR		858.00
(001832) 01-0000-0-1110-1000-3501-823-0000	NO REPORTING RE,STATE U	DR	595.00	
(001861) 01-0000-0-1110-1000-3502-823-0000	NO REPORTING RE,STATE U	CR		2.00
(001880) 01-0000-0-1110-1000-3601-823-0000	NO REPORTING RE,WORKE	DR	2,278.00	
(001909) 01-0000-0-1110-1000-3602-823-0000	NO REPORTING RE,WORKE	CR		8.00
Net decrease to Appropriations			83,609.00	16,442.00

JE # BR22-01746 JE Trans Date 06/30/2022 JE Posted 07/19/2022		Comment BL-3rd interim GAEL		
(000348) 01-0000-0-0000-2700-1300-824-0000	NO REPORTING RE,CERT:S	DR	1.00	
(011788) 01-0000-0-0000-2700-1340-824-0000	NO REPORTING RE,CERT S	DR	7,467.00	
(000361) 01-0000-0-0000-2700-2400-824-0000	NO REPORTING RE,CLERIC.	DR	601.00	
(000383) 01-0000-0-0000-2700-2440-824-0000	NO REPORTING RE,CLASS (DR	2,500.00	
(000398) 01-0000-0-0000-2700-3101-824-0000	NO REPORTING RE,STRS:C	CR		1.00
(000414) 01-0000-0-0000-2700-3202-824-0000	NO REPORTING RE,PERS:C	DR	1,158.00	
(000432) 01-0000-0-0000-2700-3312-824-0000	NO REPORTING RE,FICA:CL	DR	65.00	
(000449) 01-0000-0-0000-2700-3331-824-0000	NO REPORTING RE,MEDICA	CR		98.00
(000463) 01-0000-0-0000-2700-3332-824-0000	NO REPORTING RE,MEDICA	DR	14.00	
(000502) 01-0000-0-0000-2700-3501-824-0000	NO REPORTING RE,STATE U	CR		34.00
(000516) 01-0000-0-0000-2700-3502-824-0000	NO REPORTING RE,STATE U	DR	4.00	
(000532) 01-0000-0-0000-2700-3601-824-0000	NO REPORTING RE,WORKE	CR		407.00
(000546) 01-0000-0-0000-2700-3602-824-0000	NO REPORTING RE,WORKE	DR	20.00	
(000891) 01-0000-0-0000-3140-2200-824-0000	NO REPORTING RE,CLASS:S	DR	616.00	
(000914) 01-0000-0-0000-3140-3202-824-0000	NO REPORTING RE,PERS:C	DR	12.00	
(000928) 01-0000-0-0000-3140-3312-824-0000	NO REPORTING RE,FICA:CL	DR	1.00	

Selection Grouped by Org, Fiscal Year, JE# - Sorted by JE Item #, (Org = 14, JE Type = R, Starting Post Date = 6/1/2022, Ending Post Date = 7/31/2022, Unposted JEs? = N, End Bud Bal? = O, JE# Page Break? = N, Description? = A, Recap? = N)

ESCAPE ONLINE

Effective 04/14/2022 through 07/29/2022

Fiscal Year 2022

Account	Description	Comment	From	To
(continued)	JE # BR22-01746	JE Trans Date 06/30/2022	JE Posted 07/19/2022	Comment BL-3rd interim GAEL
(001334) 01-0000-0-0000-8200-2200-824-0000	NO REPORTING RE,CLASS:I	CR		4,822.00
(001351) 01-0000-0-0000-8200-2240-824-0000	NO REPORTING RE,CLASS I	DR	943.00	
(001368) 01-0000-0-0000-8200-3202-824-0000	NO REPORTING RE,PERS:C	DR	216.00	
(001381) 01-0000-0-0000-8200-3312-824-0000	NO REPORTING RE,FICA:CL	CR		186.00
(001394) 01-0000-0-0000-8200-3332-824-0000	NO REPORTING RE,MEDICA	CR		44.00
(001407) 01-0000-0-0000-8200-3402-824-0000	NO REPORTING RE,HEALTH	DR	1.00	
(001419) 01-0000-0-0000-8200-3502-824-0000	NO REPORTING RE,STATE U	DR	9.00	
(001432) 01-0000-0-0000-8200-3602-824-0000	NO REPORTING RE,WORKE	CR		58.00
(001451) 01-0000-0-0000-8200-4300-824-0000	NO REPORTING RE,MATERI	DR	1,006.00	
(001495) 01-0000-0-0000-8300-2900-824-0000	NO REPORTING RE,CLASS:(CR		3,318.00
(001499) 01-0000-0-0000-8300-2930-824-0000	NO REPORTING RE,OTHER	CR		1,852.00
(001516) 01-0000-0-0000-8300-3312-824-0000	NO REPORTING RE,FICA:CL	CR		328.00
(001529) 01-0000-0-0000-8300-3332-824-0000	NO REPORTING RE,MEDICA	CR		77.00
(001551) 01-0000-0-0000-8300-3502-824-0000	NO REPORTING RE,STATE U	CR		27.00
(001563) 01-0000-0-0000-8300-3602-824-0000	NO REPORTING RE,WORKE	CR		104.00
(001593) 01-0000-0-1110-1000-1100-824-0000	NO REPORTING RE,CERT:TI	DR	927.00	
(001622) 01-0000-0-1110-1000-1140-824-0000	NO REPORTING RE,CERT S,	DR	8,051.00	
(011170) 01-0000-0-1110-1000-2100-824-0000	NO REPORTING RE,CLASS:I	DR	254.00	
(001686) 01-0000-0-1110-1000-3101-824-0000	NO REPORTING RE,STRS:C	DR	6,734.00	
(001722) 01-0000-0-1110-1000-3202-824-0000	NO REPORTING RE,PERS:C	CR		41.00
(001735) 01-0000-0-1110-1000-3311-824-0000	NO REPORTING RE,FICA:CE	CR		76.00
(001754) 01-0000-0-1110-1000-3312-824-0000	NO REPORTING RE,FICA:CL	DR	8.00	
(001774) 01-0000-0-1110-1000-3331-824-0000	NO REPORTING RE,MEDICA	DR	798.00	
(001803) 01-0000-0-1110-1000-3332-824-0000	NO REPORTING RE,MEDICA	DR	1.00	
(001833) 01-0000-0-1110-1000-3501-824-0000	NO REPORTING RE,STATE U	DR	275.00	
(001862) 01-0000-0-1110-1000-3502-824-0000	NO REPORTING RE,STATE U	DR	1.00	
(001881) 01-0000-0-1110-1000-3601-824-0000	NO REPORTING RE,WORKE	DR	1,055.00	
(001910) 01-0000-0-1110-1000-3602-824-0000	NO REPORTING RE,WORKE	DR	2.00	

Net decrease to Appropriations **32,740.00** **11,473.00**

JE # BR22-01747	JE Trans Date 06/30/2022	JE Posted 07/19/2022	Comment BL-3rd interim WL
(029289) 01-0000-0-0000-2495-2290-827-0000		NO REPORTING RE,CLASS I	DR 103.00
(029294) 01-0000-0-0000-2495-3312-827-0000		NO REPORTING RE,FICA:CL	DR 7.00
(029295) 01-0000-0-0000-2495-3332-827-0000		NO REPORTING RE,MEDICA	DR 2.00
(029297) 01-0000-0-0000-2495-3502-827-0000		NO REPORTING RE,STATE U	DR 1.00
(029298) 01-0000-0-0000-2495-3602-827-0000		NO REPORTING RE,WORKE	DR 2.00
(000349) 01-0000-0-0000-2700-1300-827-0000		NO REPORTING RE,CERT:S	CR 1.00

Selection Grouped by Org, Fiscal Year, JE# - Sorted by JE Item #, (Org = 14, JE Type = R, Starting Post Date = 6/1/2022, Ending Post Date = 7/31/2022, Unposted JEs? = N, End Bud Bal? = O, JE# Page Break? = N, Description? = A, Recap? = N)

ESCAPE ONLINE

Effective 04/14/2022 through 07/29/2022

Fiscal Year 2022

Account	Description	Comment	From	To
(continued) JE # BR22-01747 JE Trans Date 06/30/2022 JE Posted 07/19/2022		Comment BL-3rd interim WL		
(000357) 01-0000-0-0000-2700-1340-827-0000	NO REPORTING RE,CERT S	CR		150.00
(000362) 01-0000-0-0000-2700-2400-827-0000	NO REPORTING RE,CLERIC,	CR		1,327.00
(000384) 01-0000-0-0000-2700-2440-827-0000	NO REPORTING RE,CLASS (CR		1,132.00
(000399) 01-0000-0-0000-2700-3101-827-0000	NO REPORTING RE,STRS:C	CR		26.00
(000415) 01-0000-0-0000-2700-3202-827-0000	NO REPORTING RE,PERS:C	CR		779.00
(000434) 01-0000-0-0000-2700-3312-827-0000	NO REPORTING RE,FICA:CL	DR	97.00	
(000450) 01-0000-0-0000-2700-3331-827-0000	NO REPORTING RE,MEDICA	DR	133.00	
(000465) 01-0000-0-0000-2700-3332-827-0000	NO REPORTING RE,MEDICA	CR		18.00
(000503) 01-0000-0-0000-2700-3501-827-0000	NO REPORTING RE,STATE U	DR	46.00	
(000518) 01-0000-0-0000-2700-3502-827-0000	NO REPORTING RE,STATE U	CR		5.00
(000533) 01-0000-0-0000-2700-3601-827-0000	NO REPORTING RE,WORKE	DR	177.00	
(000548) 01-0000-0-0000-2700-3602-827-0000	NO REPORTING RE,WORKE	CR		22.00
(000892) 01-0000-0-0000-3140-2200-827-0000	NO REPORTING RE,CLASS:!	DR	893.00	
(000915) 01-0000-0-0000-3140-3202-827-0000	NO REPORTING RE,PERS:C	DR	67.00	
(000929) 01-0000-0-0000-3140-3312-827-0000	NO REPORTING RE,FICA:CL	DR	18.00	
(000944) 01-0000-0-0000-3140-3332-827-0000	NO REPORTING RE,MEDICA	DR	4.00	
(000964) 01-0000-0-0000-3140-3502-827-0000	NO REPORTING RE,STATE U	DR	1.00	
(000978) 01-0000-0-0000-3140-3602-827-0000	NO REPORTING RE,WORKE	DR	5.00	
(001335) 01-0000-0-0000-8200-2200-827-0000	NO REPORTING RE,CLASS:!	CR		37.00
(001352) 01-0000-0-0000-8200-2240-827-0000	NO REPORTING RE,CLASS I	CR		2,781.00
(001369) 01-0000-0-0000-8200-3202-827-0000	NO REPORTING RE,PERS:C	DR	282.00	
(001382) 01-0000-0-0000-8200-3312-827-0000	NO REPORTING RE,FICA:CL	CR		64.00
(001395) 01-0000-0-0000-8200-3332-827-0000	NO REPORTING RE,MEDICA	CR		8.00
(001408) 01-0000-0-0000-8200-3402-827-0000	NO REPORTING RE,HEALTH	DR	77,368.00	
(001420) 01-0000-0-0000-8200-3502-827-0000	NO REPORTING RE,STATE U	CR		26.00
(001433) 01-0000-0-0000-8200-3602-827-0000	NO REPORTING RE,WORKE	CR		8.00
(001452) 01-0000-0-0000-8200-4300-827-0000	NO REPORTING RE,MATERI	DR	957.00	
(001496) 01-0000-0-0000-8300-2900-827-0000	NO REPORTING RE,CLASS:!	CR		1,122.00
(001500) 01-0000-0-0000-8300-2930-827-0000	NO REPORTING RE,OTHER	DR	81.00	
(013581) 01-0000-0-0000-8300-2940-827-0000	NO REPORTING RE,OTHER	CR		240.00
(001506) 01-0000-0-0000-8300-3202-827-0000	NO REPORTING RE,PERS:C	CR		20.00
(001517) 01-0000-0-0000-8300-3312-827-0000	NO REPORTING RE,FICA:CL	CR		128.00
(001530) 01-0000-0-0000-8300-3332-827-0000	NO REPORTING RE,MEDICA	CR		30.00
(001542) 01-0000-0-0000-8300-3402-827-0000	NO REPORTING RE,HEALTH	CR		1.00
(001552) 01-0000-0-0000-8300-3502-827-0000	NO REPORTING RE,STATE U	CR		11.00
(001564) 01-0000-0-0000-8300-3602-827-0000	NO REPORTING RE,WORKE	CR		40.00
(001594) 01-0000-0-1110-1000-1100-827-0000	NO REPORTING RE,CERT:TI	CR		1,534.00

Selection Grouped by Org, Fiscal Year, JE# - Sorted by JE Item #, (Org = 14, JE Type = R, Starting Post Date = 6/1/2022, Ending Post Date = 7/31/2022, Unposted JEs? = N, End Bud Bal? = O, JE# Page Break? = N, Description? = A, Recap? = N)

ESCAPE ONLINE

Page 53 of 88

Effective 04/14/2022 through 07/29/2022

Fiscal Year 2022

Account	Description	Comment	From	To
(continued) JE # BR22-01747 JE Trans Date 06/30/2022 JE Posted 07/19/2022		Comment BL-3rd interim WL		
(001623) 01-0000-0-1110-1000-1140-827-0000	NO REPORTING RE,CERT S.	DR	12,243.00	
(011171) 01-0000-0-1110-1000-2100-827-0000	NO REPORTING RE,CLASS:I	DR	4,822.00	
(001687) 01-0000-0-1110-1000-3101-827-0000	NO REPORTING RE,STRS:C	DR	4,773.00	
(014188) 01-0000-0-1110-1000-3102-827-0000	NO REPORTING RE,STRS:C	CR		267.00
(001736) 01-0000-0-1110-1000-3311-827-0000	NO REPORTING RE,FICA:CE	CR		246.00
(001775) 01-0000-0-1110-1000-3331-827-0000	NO REPORTING RE,MEDICA	DR	1,965.00	
(001804) 01-0000-0-1110-1000-3332-827-0000	NO REPORTING RE,MEDICA	DR	10.00	
(001812) 01-0000-0-1110-1000-3401-827-0000	NO REPORTING RE,HEALTH	DR	1.00	
(001834) 01-0000-0-1110-1000-3501-827-0000	NO REPORTING RE,STATE U	DR	713.00	
(001863) 01-0000-0-1110-1000-3502-827-0000	NO REPORTING RE,STATE U	DR	4.00	
(001882) 01-0000-0-1110-1000-3601-827-0000	NO REPORTING RE,WORKE	DR	2,596.00	
(001911) 01-0000-0-1110-1000-3602-827-0000	NO REPORTING RE,WORKE	DR	14.00	
Net decrease to Appropriations			107,385.00	10,023.00

JE # BR22-01748 JE Trans Date 06/30/2022 JE Posted 07/19/2022	Description	Comment	From	To
(025993) 01-0000-0-0000-2420-2230-831-0000	NO REPORTING RE,CLASS I	DR	6,600.00	
(026841) 01-0000-0-0000-2495-2230-831-0000	NO REPORTING RE,CLASS I	CR		1.00
(000350) 01-0000-0-0000-2700-1300-831-0000	NO REPORTING RE,CERT:S	CR		2.00
(000363) 01-0000-0-0000-2700-2400-831-0000	NO REPORTING RE,CLERIC.	CR		1,815.00
(000385) 01-0000-0-0000-2700-2440-831-0000	NO REPORTING RE,CLASS (DR	2,064.00	
(000400) 01-0000-0-0000-2700-3101-831-0000	NO REPORTING RE,STRS:C	CR		1.00
(000416) 01-0000-0-0000-2700-3202-831-0000	NO REPORTING RE,PERS:C	CR		222.00
(000435) 01-0000-0-0000-2700-3312-831-0000	NO REPORTING RE,FICA:CL	DR	59.00	
(000451) 01-0000-0-0000-2700-3331-831-0000	NO REPORTING RE,MEDICA	DR	104.00	
(000466) 01-0000-0-0000-2700-3332-831-0000	NO REPORTING RE,MEDICA	DR	14.00	
(000504) 01-0000-0-0000-2700-3501-831-0000	NO REPORTING RE,STATE U	DR	37.00	
(000519) 01-0000-0-0000-2700-3502-831-0000	NO REPORTING RE,STATE U	DR	18.00	
(000534) 01-0000-0-0000-2700-3601-831-0000	NO REPORTING RE,WORKE	DR	141.00	
(000549) 01-0000-0-0000-2700-3602-831-0000	NO REPORTING RE,WORKE	DR	241.00	
(000645) 01-0000-0-0000-3110-2400-831-0000	NO REPORTING RE,CLERIC.	DR	229.00	
(013712) 01-0000-0-0000-3110-2430-831-0000	NO REPORTING RE,CLASS (CR		1,734.00
(000674) 01-0000-0-0000-3110-3202-831-0000	NO REPORTING RE,PERS:C	CR		460.00
(000690) 01-0000-0-0000-3110-3312-831-0000	NO REPORTING RE,FICA:CL	DR	396.00	
(000713) 01-0000-0-0000-3110-3332-831-0000	NO REPORTING RE,MEDICA	DR	92.00	
(000753) 01-0000-0-0000-3110-3502-831-0000	NO REPORTING RE,STATE U	DR	32.00	
(000775) 01-0000-0-0000-3110-3602-831-0000	NO REPORTING RE,WORKE	DR	208.00	
(000893) 01-0000-0-0000-3140-2200-831-0000	NO REPORTING RE,CLASS:!	DR	110.00	

Selection Grouped by Org, Fiscal Year, JE# - Sorted by JE Item #, (Org = 14, JE Type = R, Starting Post Date = 6/1/2022, Ending Post Date = 7/31/2022, Unposted JEs? = N, End Bud Bal? = O, JE# Page Break? = N, Description? = A, Recap? = N)

ESCAPE ONLINE

Page 54 of 88

Effective 04/14/2022 through 07/29/2022

Fiscal Year 2022

Account		Description	Comment	From	To
(continued)	JE # BR22-01748	JE Trans Date 06/30/2022	JE Posted 07/19/2022	Comment BL-3rd interim BMS	
(026768)	01-0000-0-0000-3140-2230-831-0000	NO REPORTING RE,CLASS I	DR	111.00	
(000916)	01-0000-0-0000-3140-3202-831-0000	NO REPORTING RE,PERS:C	CR		82.00
(000930)	01-0000-0-0000-3140-3312-831-0000	NO REPORTING RE,FICA:CL	CR		2.00
(000945)	01-0000-0-0000-3140-3332-831-0000	NO REPORTING RE,MEDICA	DR	8.00	
(000965)	01-0000-0-0000-3140-3502-831-0000	NO REPORTING RE,STATE U	DR	3.00	
(000979)	01-0000-0-0000-3140-3602-831-0000	NO REPORTING RE,WORKE	DR	94.00	
(028003)	01-0000-0-0000-3160-2930-831-0000	NO REPORTING RE,OTHER	DR	360.00	
(028005)	01-0000-0-0000-3160-3102-831-0000	NO REPORTING RE,STRS:C	DR	61.00	
(028009)	01-0000-0-0000-3160-3332-831-0000	NO REPORTING RE,MEDICA	DR	6.00	
(028011)	01-0000-0-0000-3160-3502-831-0000	NO REPORTING RE,STATE U	DR	2.00	
(028012)	01-0000-0-0000-3160-3602-831-0000	NO REPORTING RE,WORKE	DR	7.00	
(001336)	01-0000-0-0000-8200-2200-831-0000	NO REPORTING RE,CLASS:I	CR		907.00
(001353)	01-0000-0-0000-8200-2240-831-0000	NO REPORTING RE,CLASS I	DR	671.00	
(001370)	01-0000-0-0000-8200-3202-831-0000	NO REPORTING RE,PERS:C	DR	177.00	
(001383)	01-0000-0-0000-8200-3312-831-0000	NO REPORTING RE,FICA:CL	CR		111.00
(001396)	01-0000-0-0000-8200-3332-831-0000	NO REPORTING RE,MEDICA	CR		26.00
(001421)	01-0000-0-0000-8200-3502-831-0000	NO REPORTING RE,STATE U	DR	3.00	
(001434)	01-0000-0-0000-8200-3602-831-0000	NO REPORTING RE,WORKE	CR		34.00
(001453)	01-0000-0-0000-8200-4300-831-0000	NO REPORTING RE,MATERI	DR	260.00	
(001475)	01-0000-0-0000-8300-2200-831-0000	NO REPORTING RE,CLASS:I	DR	3,524.00	
(011679)	01-0000-0-0000-8300-2230-831-0000	NO REPORTING RE,CLASS I	DR	99.00	
(001484)	01-0000-0-0000-8300-2240-831-0000	NO REPORTING RE,CLASS I	DR	201.00	
(001507)	01-0000-0-0000-8300-3202-831-0000	NO REPORTING RE,PERS:C	DR	709.00	
(001518)	01-0000-0-0000-8300-3312-831-0000	NO REPORTING RE,FICA:CL	DR	191.00	
(001531)	01-0000-0-0000-8300-3332-831-0000	NO REPORTING RE,MEDICA	DR	45.00	
(001553)	01-0000-0-0000-8300-3502-831-0000	NO REPORTING RE,STATE U	DR	15.00	
(001565)	01-0000-0-0000-8300-3602-831-0000	NO REPORTING RE,WORKE	DR	59.00	
(001595)	01-0000-0-1110-1000-1100-831-0000	NO REPORTING RE,CERT:TI	CR		1,629.00
(001624)	01-0000-0-1110-1000-1140-831-0000	NO REPORTING RE,CERT S.	CR		283.00
(001688)	01-0000-0-1110-1000-3101-831-0000	NO REPORTING RE,STRS:C	DR	2,513.00	
(001737)	01-0000-0-1110-1000-3311-831-0000	NO REPORTING RE,FICA:CE	CR		235.00
(001776)	01-0000-0-1110-1000-3331-831-0000	NO REPORTING RE,MEDICA	DR	1,219.00	
(001813)	01-0000-0-1110-1000-3401-831-0000	NO REPORTING RE,HEALTH	DR	9.00	
(001835)	01-0000-0-1110-1000-3501-831-0000	NO REPORTING RE,STATE U	DR	419.00	
(001883)	01-0000-0-1110-1000-3601-831-0000	NO REPORTING RE,WORKE	DR	1,610.00	
Net decrease to Appropriations				22,721.00	7,544.00

Selection Grouped by Org, Fiscal Year, JE# - Sorted by JE Item #, (Org = 14, JE Type = R, Starting Post Date = 6/1/2022, Ending Post Date = 7/31/2022, Unposted JEs? = N, End Bud Bal? = O, JE# Page Break? = N, Description? = A, Recap? = N)

ESCAPE ONLINE

Page 55 of 88

Effective 04/14/2022 through 07/29/2022

Fiscal Year 2022

Account		Description	Comment	From	To
JE # BR22-01749		JE Trans Date 06/30/2022	JE Posted 07/19/2022	Comment BL-3rd interim MH	
(026003)	01-0000-0-0000-2420-2230-832-0000	NO REPORTING RE,CLASS I	DR	6,600.00	
(016552)	01-0000-0-0000-2700-1340-832-0000	NO REPORTING RE,CERT S	CR		755.00
(000364)	01-0000-0-0000-2700-2400-832-0000	NO REPORTING RE,CLERIC.	CR		908.00
(000386)	01-0000-0-0000-2700-2440-832-0000	NO REPORTING RE,CLASS (DR	4,149.00	
(000401)	01-0000-0-0000-2700-3101-832-0000	NO REPORTING RE,STRS:C	CR		1.00
(000417)	01-0000-0-0000-2700-3202-832-0000	NO REPORTING RE,PERS:C	DR	165.00	
(000436)	01-0000-0-0000-2700-3312-832-0000	NO REPORTING RE,FICA:CL	DR	179.00	
(000452)	01-0000-0-0000-2700-3331-832-0000	NO REPORTING RE,MEDICA	DR	273.00	
(000467)	01-0000-0-0000-2700-3332-832-0000	NO REPORTING RE,MEDICA	CR		5.00
(000505)	01-0000-0-0000-2700-3501-832-0000	NO REPORTING RE,STATE U	DR	94.00	
(000520)	01-0000-0-0000-2700-3502-832-0000	NO REPORTING RE,STATE U	DR	1.00	
(000535)	01-0000-0-0000-2700-3601-832-0000	NO REPORTING RE,WORKE	DR	364.00	
(000550)	01-0000-0-0000-2700-3602-832-0000	NO REPORTING RE,WORKE	CR		7.00
(000646)	01-0000-0-0000-3110-2400-832-0000	NO REPORTING RE,CLERIC.	CR		1,309.00
(026781)	01-0000-0-0000-3110-2430-832-0000	NO REPORTING RE,CLASS (CR		376.00
(000675)	01-0000-0-0000-3110-3202-832-0000	NO REPORTING RE,PERS:C	CR		508.00
(000691)	01-0000-0-0000-3110-3312-832-0000	NO REPORTING RE,FICA:CL	CR		167.00
(000714)	01-0000-0-0000-3110-3332-832-0000	NO REPORTING RE,MEDICA	CR		39.00
(000754)	01-0000-0-0000-3110-3502-832-0000	NO REPORTING RE,STATE U	CR		14.00
(000776)	01-0000-0-0000-3110-3602-832-0000	NO REPORTING RE,WORKE	CR		51.00
(000894)	01-0000-0-0000-3140-2200-832-0000	NO REPORTING RE,CLASS:S	DR	358.00	
(016695)	01-0000-0-0000-3140-2230-832-0000	NO REPORTING RE,CLASS I	DR	669.00	
(000917)	01-0000-0-0000-3140-3202-832-0000	NO REPORTING RE,PERS:C	DR	85.00	
(000931)	01-0000-0-0000-3140-3312-832-0000	NO REPORTING RE,FICA:CL	DR	120.00	
(000946)	01-0000-0-0000-3140-3332-832-0000	NO REPORTING RE,MEDICA	DR	27.00	
(000966)	01-0000-0-0000-3140-3502-832-0000	NO REPORTING RE,STATE U	DR	9.00	
(000980)	01-0000-0-0000-3140-3602-832-0000	NO REPORTING RE,WORKE	DR	37.00	
(031434)	01-0000-0-0000-3160-1930-832-0000	NO REPORTING RE,CERT O	DR	158.00	
(028014)	01-0000-0-0000-3160-3101-832-0000	NO REPORTING RE,STRS:C	DR	85.00	
(031435)	01-0000-0-0000-3160-3311-832-0000	NO REPORTING RE,FICA:CE	CR		22.00
(031436)	01-0000-0-0000-3160-3331-832-0000	NO REPORTING RE,MEDICA	DR	2.00	
(031438)	01-0000-0-0000-3160-3501-832-0000	NO REPORTING RE,STATE U	DR	1.00	
(031439)	01-0000-0-0000-3160-3601-832-0000	NO REPORTING RE,WORKE	DR	3.00	
(001337)	01-0000-0-0000-8200-2200-832-0000	NO REPORTING RE,CLASS:S	CR		7,721.00
(001354)	01-0000-0-0000-8200-2240-832-0000	NO REPORTING RE,CLASS I	DR	1,434.00	
(013687)	01-0000-0-0000-8200-2290-832-0000	NO REPORTING RE,CLASS I	CR		233.00
(001371)	01-0000-0-0000-8200-3202-832-0000	NO REPORTING RE,PERS:C	DR	552.00	

Selection Grouped by Org, Fiscal Year, JE# - Sorted by JE Item #, (Org = 14, JE Type = R, Starting Post Date = 6/1/2022, Ending Post Date = 7/31/2022, Unposted JEs? = N, End Bud Bal? = O, JE# Page Break? = N, Description? = A, Recap? = N)

ESCAPE ONLINE

Page 56 of 88

Effective 04/14/2022 through 07/29/2022

Fiscal Year 2022

Account	Description	Comment	From	To
(continued) JE # BR22-01749 JE Trans Date 06/30/2022 JE Posted 07/19/2022		Comment BL-3rd interim MH		
(001384) 01-0000-0-0000-8200-3312-832-0000	NO REPORTING RE,FICA:CL	DR	942.00	
(001397) 01-0000-0-0000-8200-3332-832-0000	NO REPORTING RE,MEDICA	DR	283.00	
(001422) 01-0000-0-0000-8200-3502-832-0000	NO REPORTING RE,STATE U	DR	7.00	
(001435) 01-0000-0-0000-8200-3602-832-0000	NO REPORTING RE,WORKE	CR		27.00
(001454) 01-0000-0-0000-8200-4300-832-0000	NO REPORTING RE,MATERI	DR	888.00	
(001476) 01-0000-0-0000-8300-2200-832-0000	NO REPORTING RE,CLASS:S	DR	2,383.00	
(001485) 01-0000-0-0000-8300-2240-832-0000	NO REPORTING RE,CLASS F	DR	1,442.00	
(001508) 01-0000-0-0000-8300-3202-832-0000	NO REPORTING RE,PERS:C	CR		36.00
(001519) 01-0000-0-0000-8300-3312-832-0000	NO REPORTING RE,FICA:CL	CR		18.00
(001532) 01-0000-0-0000-8300-3332-832-0000	NO REPORTING RE,MEDICA	CR		4.00
(001544) 01-0000-0-0000-8300-3402-832-0000	NO REPORTING RE,HEALTH	DR	84.00	
(001554) 01-0000-0-0000-8300-3502-832-0000	NO REPORTING RE,STATE U	CR		2.00
(001566) 01-0000-0-0000-8300-3602-832-0000	NO REPORTING RE,WORKE	CR		6.00
(001596) 01-0000-0-1110-1000-1100-832-0000	NO REPORTING RE,CERT:TI	CR		3,974.00
(001625) 01-0000-0-1110-1000-1140-832-0000	NO REPORTING RE,CERT S.	CR		5,416.00
(001690) 01-0000-0-1110-1000-3101-832-0000	NO REPORTING RE,STRS:C	CR		1,966.00
(001714) 01-0000-0-1110-1000-3201-832-0000	NO REPORTING RE,PERS:C	CR		521.00
(001738) 01-0000-0-1110-1000-3311-832-0000	NO REPORTING RE,FICA:CE	CR		217.00
(001778) 01-0000-0-1110-1000-3331-832-0000	NO REPORTING RE,MEDICA	DR	4,596.00	
(001837) 01-0000-0-1110-1000-3501-832-0000	NO REPORTING RE,STATE U	DR	442.00	
(001885) 01-0000-0-1110-1000-3601-832-0000	NO REPORTING RE,WORKE	DR	1,696.00	
Net decrease to Appropriations			28,128.00	24,303.00

JE # BR22-01750 JE Trans Date 06/30/2022 JE Posted 07/20/2022	Description	Comment	From	To
		Comment BD-ADJUSTING BUDGET TO FINAL 21-22 ALLOCATION		
(025128) 01-3010-0-0000-0000-8290-520-0000	BAS GNT LOW-INC,ALL OTH	DR		202.00
(025129) 01-3010-0-0000-7210-7310-520-0000	BAS GNT LOW-INC,XFER:INI	CR		78.00
(027608) 01-3010-0-1110-1000-4399-520-0000	BAS GNT LOW-INC,HOLDINC	CR		124.00
(025131) 01-3010-0-0000-0000-8290-530-0000	BAS GNT LOW-INC,ALL OTH	CR	18.00	
(025129) 01-3010-0-0000-7210-7310-520-0000	BAS GNT LOW-INC,XFER:INI	DR	1.00	
(025134) 01-3010-0-1110-1000-4399-530-0000	BAS GNT LOW-INC,HOLDINC	DR	17.00	
Net increase to Appropriations			36.00	404.00

JE # BR22-01751 JE Trans Date 06/30/2022 JE Posted 07/20/2022	Description	Comment	From	To
		Comment BL-3rd interim cov neg		
(001444) 01-0000-0-0000-8200-4300-023-0000	NO REPORTING RE,MATERI BL-3rd interim cov neg DLV	CR		183.00
(001928) 01-0000-0-1110-1000-4300-023-0000	NO REPORTING RE,MATERI BL-3rd interim cov neg DLV	DR	183.00	
(016394) 01-0000-0-0000-8200-4300-027-0000	NO REPORTING RE,MATERI BL-3rd interim cov neg WL	CR		957.00

Selection Grouped by Org, Fiscal Year, JE# - Sorted by JE Item #, (Org = 14, JE Type = R, Starting Post Date = 6/1/2022, Ending Post Date = 7/31/2022, Unposted JEs? = N, End Bud Bal? = O, JE# Page Break? = N, Description? = A, Recap? = N)

ESCAPE ONLINE

Effective 04/14/2022 through 07/29/2022

Fiscal Year 2022

Account	Description	Comment	From	To
(continued) JE # BR22-01751 JE Trans Date 06/30/2022 JE Posted 07/20/2022 Comment BL-3rd interim cov neg				
(001600) 01-0000-0-1110-1000-1130-027-0000	NO REPORTING RE,CERT S. BL-3rd interim cov neg WL	DR	864.00	
(001673) 01-0000-0-1110-1000-3101-027-0000	NO REPORTING RE,STRS:C BL-3rd interim cov neg WL	DR	93.00	
			1,140.00	1,140.00

JE # BR22-01752 JE Trans Date 06/30/2022 JE Posted 07/20/2022 Comment BL-3rd interim cov neg				
(008678) 01-9016-0-1110-1000-2130-021-0052	DONATIONS,CLASS INSTR F	CR		878.00
(008692) 01-9016-0-1110-1000-3312-021-0052	DONATIONS,FICA:CLASS,IN	CR		55.00
(008701) 01-9016-0-1110-1000-3332-021-0052	DONATIONS,MEDICARE:CLA	CR		13.00
(008711) 01-9016-0-1110-1000-3502-021-0052	DONATIONS,STATE UNEMPI	CR		5.00
(008720) 01-9016-0-1110-1000-3602-021-0052	DONATIONS,WORKERS' CO	CR		17.00
(008735) 01-9016-0-1110-1000-4300-021-0052	DONATIONS,MATERIALS & S	DR	968.00	
			968.00	968.00

JE # BR22-01753 JE Trans Date 05/10/2022 JE Posted 07/20/2022 Comment BL-COV NEG, CHAPUT SEYMOUR BUS				
(016851) 01-9016-0-1110-1000-5710-021-0051	DONATIONS,XFER OF DIRE	CR		119.00
(028448) 01-9016-0-1110-1000-4395-021-0051	DONATIONS,FOOD FOR WO	DR	119.00	
			119.00	119.00

JE # BR22-01754 JE Trans Date 06/30/2022 JE Posted 07/20/2022 Comment BD-ADJUSTING TO 21-22 ALLOCATION				
(005502) 01-4035-0-0000-0000-8290-930-0000	ESEA:TEACHER QU,ALL OTI	DR		1,590.00
(005536) 01-4035-0-0000-7210-7310-930-0000	ESEA:TEACHER QU,XFER:IN	CR		105.00
(005582) 01-4035-0-1110-1000-4399-930-0000	ESEA:TEACHER QU,HOLDIN	CR		1,485.00
(005501) 01-4035-0-0000-0000-8290-920-0000	ESEA:TEACHER QU,ALL OTI	DR		749.00
(005535) 01-4035-0-0000-7210-7310-920-0000	ESEA:TEACHER QU,XFER:IN	CR		49.00
(005581) 01-4035-0-1110-1000-4399-920-0000	ESEA:TEACHER QU,HOLDIN	CR		700.00
(024160) 01-4127-0-0000-0000-8290-520-0000	ESEA:STDNT SUPP,ALL OTI	DR		456.00
(024161) 01-4127-0-0000-7210-7310-520-0000	ESEA:STDNT SUPP,XFER:IN	CR		30.00
(024162) 01-4127-0-1110-1000-4399-520-0000	ESEA:STDNT SUPP,HOLDIN	CR		426.00
(025151) 01-4127-0-0000-0000-8290-530-0000	ESEA:STDNT SUPP,ALL OTI	DR		1,205.00
(025148) 01-4127-0-0000-7210-7310-530-0000	ESEA:STDNT SUPP,XFER:IN	CR		79.00
(027639) 01-4127-0-1110-1000-4399-530-0000	ESEA:STDNT SUPP,HOLDIN	CR		1,126.00
(032264) 01-7812-0-0000-0000-8590-530-0000	ETHNIC STUDIES,ALL OTHE	DR		87,079.00
(032270) 01-7812-0-1240-1000-4399-530-0000	ETHNIC STUDIES,HOLDING	CR		87,079.00

Selection Grouped by Org, Fiscal Year, JE# - Sorted by JE Item #, (Org = 14, JE Type = R, Starting Post Date = 6/1/2022, Ending Post Date = 7/31/2022, Unposted JEs? = N, End Bud Bal? = O, JE# Page Break? = N, Description? = A, Recap? = N)

ESCAPE ONLINE

Page 58 of 88

Effective 04/14/2022 through 07/29/2022

Fiscal Year 2022

Account	Description	Comment	From	To					
Net increase to Appropriations			.00	182,158.00					
<table border="0" style="width: 100%;"> <tr> <td style="text-align: right;">JE # BR22-01755</td> <td style="text-align: right;">JE Trans Date 06/30/2022</td> <td style="text-align: right;">JE Posted 07/20/2022</td> <td colspan="2" style="text-align: left;">Comment BL-DU9133 BONNY DOON BUS INV22-01349</td> </tr> </table>					JE # BR22-01755	JE Trans Date 06/30/2022	JE Posted 07/20/2022	Comment BL-DU9133 BONNY DOON BUS INV22-01349	
JE # BR22-01755	JE Trans Date 06/30/2022	JE Posted 07/20/2022	Comment BL-DU9133 BONNY DOON BUS INV22-01349						
(003956) 01-0723-0-0000-3600-2290-848-0000	TRANSPORT:HOME,CLASS I	BL-DU9133 BONNY DOON BUS INV22-01349, CK1004267	CR	523.00					
(003940) 01-0723-0-0000-0000-8699-848-0000	TRANSPORT:HOME,ALL OTI		DR	523.00					
Net increase to Appropriations			.00	1,046.00					
<table border="0" style="width: 100%;"> <tr> <td style="text-align: right;">JE # BR22-01756</td> <td style="text-align: right;">JE Trans Date 06/30/2022</td> <td style="text-align: right;">JE Posted 07/20/2022</td> <td colspan="2" style="text-align: left;">Comment BL-DU89133</td> </tr> </table>					JE # BR22-01756	JE Trans Date 06/30/2022	JE Posted 07/20/2022	Comment BL-DU89133	
JE # BR22-01756	JE Trans Date 06/30/2022	JE Posted 07/20/2022	Comment BL-DU89133						
(007924) 01-9010-0-0000-8110-4300-049-FACU	OTHER RESTRICTE,MATERI	BL-DU89133 SP OLYMPICS CIV PER CK2144 INV22-01388	CR	720.00					
(007599) 01-9010-0-0000-0000-8699-049-FACU	OTHER RESTRICTE,ALL OTI	BL-DU89133 SP OLYMPICS CIV PER CK2144 INV22-01388	DR	720.00					
(007924) 01-9010-0-0000-8110-4300-049-FACU	OTHER RESTRICTE,MATERI	BL-DU89133 MENS SR BSBL CIV PER CK2144 INV22-01388	CR	1,400.00					
(007599) 01-9010-0-0000-0000-8699-049-FACU	OTHER RESTRICTE,ALL OTI	BL-DU89133 MENS SR BSBL CIV PER CK2144 INV22-01388	DR	1,400.00					
(007924) 01-9010-0-0000-8110-4300-049-FACU	OTHER RESTRICTE,MATERI	BL-DU89133 LACROSSE THE BAY CIV PER CK2144 INV22-01388	CR	840.00					
(007599) 01-9010-0-0000-0000-8699-049-FACU	OTHER RESTRICTE,ALL OTI	BL-DU89133 LACROSSE THE BAY CIV PER CK2144 INV22-01388	DR	840.00					
(007924) 01-9010-0-0000-8110-4300-049-FACU	OTHER RESTRICTE,MATERI	BL-DU89133 SC W.POLO CIV PER CK2144 INV22-01388	CR	140.00					
(007599) 01-9010-0-0000-0000-8699-049-FACU	OTHER RESTRICTE,ALL OTI	BL-DU89133 SC W.POLO CIV PER CK2144 INV22-01388	DR	140.00					
(007924) 01-9010-0-0000-8110-4300-049-FACU	OTHER RESTRICTE,MATERI	BL-DU89133 QUICKSILVER SWIM CIV PER CK2144 INV22-01388	CR	960.00					
(007599) 01-9010-0-0000-0000-8699-049-FACU	OTHER RESTRICTE,ALL OTI	BL-DU89133 QUICKSILVER SWIM CIV PER CK2144 INV22-01388	DR	960.00					
(007924) 01-9010-0-0000-8110-4300-049-FACU	OTHER RESTRICTE,MATERI	BL-DU89133 POP WARNER CIV PER CK2144 INV22-01388	CR	1,100.00					
(007599) 01-9010-0-0000-0000-8699-049-FACU	OTHER RESTRICTE,ALL OTI	BL-DU89133 POP WARNER CIV PER CK2144 INV22-01388	DR	1,100.00					
(007943) 01-9010-0-0000-8200-2290-899-FACU	OTHER RESTRICTE,CLASS I	BL-DU89133 POP WARNER CIV PER CK2144 INV22-01388 O/C	CR	500.00					
(007626) 01-9010-0-0000-0000-8699-899-FACU	OTHER RESTRICTE,ALL OTI	BL-DU89133 POP WARNER CIV PER CK2144 INV22-01388 O/C	DR	500.00					

Selection Grouped by Org, Fiscal Year, JE# - Sorted by JE Item #, (Org = 14, JE Type = R, Starting Post Date = 6/1/2022, Ending Post Date = 7/31/2022,
Unposted JEs? = N, End Bud Bal? = O, JE# Page Break? = N, Description? = A, Recap? = N)

ESCAPE ONLINE

Page 59 of 88

Effective 04/14/2022 through 07/29/2022

Fiscal Year 2022

Account	Description	Comment	From	To
(continued) JE # BR22-01756 JE Trans Date 06/30/2022 JE Posted 07/20/2022 Comment BL-DU89133				
(007924) 01-9010-0-0000-8110-4300-049- FACU	OTHER RESTRICTE,MATERI	BL-DU89133 CABRILLO GALS CIV	CR	720.00
		PER CK2144 INV22-01388		
(007599) 01-9010-0-0000-0000-8699-049- FACU	OTHER RESTRICTE,ALL OT	BL-DU89133 CABRILLO GALS CIV	DR	720.00
		PER CK2144 INV22-01388		
(007924) 01-9010-0-0000-8110-4300-049- FACU	OTHER RESTRICTE,MATERI	BL-DU89133 MID CNTY BKB CIV PER	CR	750.00
		CK2144 INV22-01388		
(007599) 01-9010-0-0000-0000-8699-049- FACU	OTHER RESTRICTE,ALL OT	BL-DU89133 MID CNTY BKB CIV PER	DR	750.00
		CK2144 INV22-01388		
(007924) 01-9010-0-0000-8110-4300-049- FACU	OTHER RESTRICTE,MATERI	BL-DU89133 KOOKS LACRSS CIV	CR	200.00
		PER CK2144 INV22-01388		
(007599) 01-9010-0-0000-0000-8699-049- FACU	OTHER RESTRICTE,ALL OT	BL-DU89133 KOOKS LACRSS CIV	DR	200.00
		PER CK2144 INV22-01388		
Net increase to Appropriations			.00	14,660.00

JE # BR22-01757 JE Trans Date 06/30/2022 JE Posted 07/21/2022 Comment JL-Decrease District Set Aside Transportation move to 22/23				
(026154) 40-9720-0-0000-8500-6210-048-0000	2012 SERIES A G,ARCHITEC		DR	823.00
(026155) 40-9720-0-0000-8500-6251-048-0000	2012 SERIES A G,REIMBURSE		DR	461.00
(031125) 40-9720-0-0000-8500-6280-048-0000	2012 SERIES A G,CONSTRU		DR	11,654.00
Net decrease to Appropriations			12,938.00	.00

JE # BR22-01758 JE Trans Date 06/30/2022 JE Posted 07/21/2022 Comment JL-Decrease District Set Aside move to FY 22/23				
(028082) 40-9720-0-0000-8500-6210-020-0000	2012 SERIES A G,ARCHITEC		DR	1,181.00
(028083) 40-9720-0-0000-8500-6251-020-0000	2012 SERIES A G,REIMBURSE		DR	430.00
Net decrease to Appropriations			1,611.00	.00

JE # BR22-01759 JE Trans Date 06/30/2022 JE Posted 07/21/2022 Comment BL-3rd interim WL				
(008681) 01-9016-0-1110-1000-2130-027-0051	DONATIONS,CLASS INSTR /		CR	1,500.00
(008684) 01-9016-0-1110-1000-2140-027-0051	DONATIONS,CLASS INSTR /		CR	180.00
(014171) 01-9016-0-1110-1000-3102-027-0051	DONATIONS,STRS:CLASSIF		CR	31.00
(008694) 01-9016-0-1110-1000-3312-027-0051	DONATIONS,FICA:CLASS,IN		CR	93.00
(008703) 01-9016-0-1110-1000-3332-027-0051	DONATIONS,MEDICARE:CLA		CR	24.00
(008713) 01-9016-0-1110-1000-3502-027-0051	DONATIONS,STATE UNEMPI		CR	8.00
(008722) 01-9016-0-1110-1000-3602-027-0051	DONATIONS,WORKERS' CO		CR	32.00
(016852) 01-9016-0-1110-1000-5710-027-0051	DONATIONS,XFER OF DIREC		DR	1.00
(017776) 01-9016-0-1160-1000-3101-027-0051	DONATIONS,STRS:CERT,IN		DR	204.00

Selection Grouped by Org, Fiscal Year, JE# - Sorted by JE Item #, (Org = 14, JE Type = R, Starting Post Date = 6/1/2022, Ending Post Date = 7/31/2022, Unposted JEs? = N, End Bud Bal? = O, JE# Page Break? = N, Description? = A, Recap? = N)

ESCAPE ONLINE

Effective 04/14/2022 through 07/29/2022

Fiscal Year 2022

Account	Description	Comment	From	To
(continued) JE # BR22-01759 JE Trans Date 06/30/2022 JE Posted 07/21/2022		Comment BL-3rd interim WL		
(017780) 01-9016-0-1160-1000-3311-027-0051	DONATIONS,FICA:CERT,INS	CR		75.00
(008755) 01-9016-0-1110-1000-4300-027-0051	DONATIONS,MATERIALS & S	DR	1,738.00	
			1,943.00	1,943.00

Account	Description	Comment	From	To
JE # BR22-01760 JE Trans Date 06/30/2022 JE Posted 07/21/2022		Comment BL-3rd interim		
(014554) 01-9016-0-1110-1000-2100-027-0052	DONATIONS,CLASS:INSTRU	DR	412.00	
(011920) 01-9016-0-1110-1000-2130-027-0052	DONATIONS,CLASS INSTR A	DR	442.00	
(028642) 01-9016-0-1110-1000-2140-027-0052	DONATIONS,CLASS INSTR A	DR	2,541.00	
(011809) 01-9016-0-1110-1000-3312-027-0052	DONATIONS,FICA:CLASS,IN	CR		7.00
(011810) 01-9016-0-1110-1000-3332-027-0052	DONATIONS,MEDICARE:CLA	CR		2.00
(011840) 01-9016-0-1110-1000-3602-027-0052	DONATIONS,WORKERS' CO	CR		2.00
(011163) 01-9016-0-1110-1000-4300-027-0052	DONATIONS,MATERIALS & S	CR		3,384.00
			3,395.00	3,395.00

Account	Description	Comment	From	To
JE # BR22-01761 JE Trans Date 06/30/2022 JE Posted 07/21/2022		Comment BL-3rd interim		
(008888) 01-9016-0-1120-2495-2200-027-2729	DONATIONS,CLASS:SUPPOI	DR	29.00	
(008889) 01-9016-0-1120-2495-2230-027-2729	DONATIONS,CLASS PUPIL S	DR	2,033.00	
(008890) 01-9016-0-1120-2495-3202-027-2729	DONATIONS,PERS:CLASSIF	CR		170.00
(008891) 01-9016-0-1120-2495-3312-027-2729	DONATIONS,FICA:CLASS,PA	CR		46.00
(008892) 01-9016-0-1120-2495-3332-027-2729	DONATIONS,MEDICARE:CLA	CR		11.00
(008893) 01-9016-0-1120-2495-3502-027-2729	DONATIONS,STATE UNEMPI	CR		4.00
(008894) 01-9016-0-1120-2495-3602-027-2729	DONATIONS,WORKERS' CO	CR		14.00
(009006) 01-9016-0-1250-1000-2130-027-2729	DONATIONS,CLASS INSTR A	DR	720.00	
(009057) 01-9016-0-1260-1000-2130-027-2729	DONATIONS,CLASS INSTR A	DR	135.00	
(009063) 01-9016-0-1260-1000-3312-027-2729	DONATIONS,FICA:CLASS,IN	DR	106.00	
(009068) 01-9016-0-1260-1000-3332-027-2729	DONATIONS,MEDICARE:CLA	DR	3.00	
(009073) 01-9016-0-1260-1000-3502-027-2729	DONATIONS,STATE UNEMPI	DR	31.00	
(009078) 01-9016-0-1260-1000-3602-027-2729	DONATIONS,WORKERS' CO	DR	15.00	
(013563) 01-9016-0-1120-1000-4300-027-2729	DONATIONS,MATERIALS & S	CR		2,827.00
			3,072.00	3,072.00

Account	Description	Comment	From	To
JE # BR22-01762 JE Trans Date 06/30/2022 JE Posted 07/21/2022		Comment BL-3rd interim		
(008934) 01-9016-0-1150-1000-5800-027-2706	DONATIONS,PROF/CONSUL	DR	584.00	
(008915) 01-9016-0-1150-1000-4300-027-2706	DONATIONS,MATERIALS & S	CR		584.00

Selection Grouped by Org, Fiscal Year, JE# - Sorted by JE Item #, (Org = 14, JE Type = R, Starting Post Date = 6/1/2022, Ending Post Date = 7/31/2022, Unposted JEs? = N, End Bud Bal? = O, JE# Page Break? = N, Description? = A, Recap? = N)

ESCAPE ONLINE

Effective 04/14/2022 through 07/29/2022

Fiscal Year 2022

Account	Description	Comment	From	To
			584.00	584.00
JE # BR22-01763 JE Trans Date 06/30/2022 JE Posted 07/21/2022 Comment BL-3rd interim				
(029300)	01-9016-0-1141-1000-2130-032-3280	DONATIONS,CLASS INSTR /		400.00
(029305)	01-9016-0-1141-1000-3312-032-3280	DONATIONS,FICA:CLASS,IN:		25.00
(029306)	01-9016-0-1141-1000-3332-032-3280	DONATIONS,MEDICARE:CLA		6.00
(029308)	01-9016-0-1141-1000-3502-032-3280	DONATIONS,STATE UNEMP		2.00
(029309)	01-9016-0-1141-1000-3602-032-3280	DONATIONS,WORKERS' CO		6.00
(013560)	01-9016-0-1110-1000-4300-032-3280	DONATIONS,MATERIALS & S	439.00	
			439.00	439.00

JE # BR22-01764 JE Trans Date 06/30/2022 JE Posted 07/25/2022 Comment BL-3rd interim				
(029528)	01-9010-0-0000-3140-2230-821-0082	OTHER RESTRICTE,CLASS I		19.00
(029538)	01-9010-0-0000-3140-2230-823-0082	OTHER RESTRICTE,CLASS I		218.00
(029558)	01-9010-0-0000-3140-2230-827-0082	OTHER RESTRICTE,CLASS I	2,071.00	
(029532)	01-9010-0-0000-3140-3202-821-0082	OTHER RESTRICTE,PERS:C		229.00
(029562)	01-9010-0-0000-3140-3202-827-0082	OTHER RESTRICTE,PERS:C		418.00
(029543)	01-9010-0-0000-3140-3312-823-0082	OTHER RESTRICTE,FICA:CL		13.00
(029563)	01-9010-0-0000-3140-3312-827-0082	OTHER RESTRICTE,FICA:CL	129.00	
(029544)	01-9010-0-0000-3140-3332-823-0082	OTHER RESTRICTE,MEDICA		3.00
(029564)	01-9010-0-0000-3140-3332-827-0082	OTHER RESTRICTE,MEDICA	30.00	
(029536)	01-9010-0-0000-3140-3502-821-0082	OTHER RESTRICTE,STATE I		1.00
(029546)	01-9010-0-0000-3140-3502-823-0082	OTHER RESTRICTE,STATE I		1.00
(029566)	01-9010-0-0000-3140-3502-827-0082	OTHER RESTRICTE,STATE I	10.00	
(029537)	01-9010-0-0000-3140-3602-821-0082	OTHER RESTRICTE,WORKE	2.00	
(029547)	01-9010-0-0000-3140-3602-823-0082	OTHER RESTRICTE,WORKE		2.00
(029567)	01-9010-0-0000-3140-3602-827-0082	OTHER RESTRICTE,WORKE	44.00	
(029850)	01-9010-0-0000-7400-2300-820-0082	OTHER RESTRICTE,CLASS:I		32,417.00
(031680)	01-9010-0-0000-7400-2430-820-0082	OTHER RESTRICTE,CLASS I		86.00
(029854)	01-9010-0-0000-7400-3202-820-0082	OTHER RESTRICTE,PERS:C		6,885.00
(029855)	01-9010-0-0000-7400-3312-820-0082	OTHER RESTRICTE,FICA:CL		2,155.00
(029856)	01-9010-0-0000-7400-3332-820-0082	OTHER RESTRICTE,MEDICA		504.00
(029857)	01-9010-0-0000-7400-3402-820-0082	OTHER RESTRICTE,HEALTH		6,621.00
(029858)	01-9010-0-0000-7400-3502-820-0082	OTHER RESTRICTE,STATE I		174.00
(029859)	01-9010-0-0000-7400-3602-820-0082	OTHER RESTRICTE,WORKE		665.00
(029526)	01-9010-0-1110-1000-4399-020-0082	OTHER RESTRICTE,HOLDIN	51,566.00	
(032178)	01-9010-0-0000-7400-2330-820-0082	OTHER RESTRICTE,CLASS I		3,441.00

Selection Grouped by Org, Fiscal Year, JE# - Sorted by JE Item #, (Org = 14, JE Type = R, Starting Post Date = 6/1/2022, Ending Post Date = 7/31/2022, Unposted JEs? = N, End Bud Bal? = O, JE# Page Break? = N, Description? = A, Recap? = N)

ESCAPE ONLINE

Page 62 of 88

Effective 04/14/2022 through 07/29/2022

Fiscal Year 2022

Account	Description	Comment	From	To
			53,852.00	53,852.00
JE # BR22-01765 JE Trans Date 06/30/2022 JE Posted 07/25/2022 Comment BL-3rd interim				
(029568)	01-9010-0-0000-3140-2230-831-0082	OTHER RESTRICTE,CLASS I	DR	15.00
(029578)	01-9010-0-0000-3140-2230-832-0082	OTHER RESTRICTE,CLASS I	DR	1,920.00
(029588)	01-9010-0-0000-3140-2230-833-0082	OTHER RESTRICTE,CLASS I	DR	1,493.00
(029598)	01-9010-0-0000-3140-2230-834-0082	OTHER RESTRICTE,CLASS I	CR	118.00
(029608)	01-9010-0-0000-3140-2230-835-0082	OTHER RESTRICTE,CLASS I	DR	2,543.00
(029572)	01-9010-0-0000-3140-3202-831-0082	OTHER RESTRICTE,PERS:C	DR	3.00
(029582)	01-9010-0-0000-3140-3202-832-0082	OTHER RESTRICTE,PERS:C	CR	114.00
(029592)	01-9010-0-0000-3140-3202-833-0082	OTHER RESTRICTE,PERS:C	CR	73.00
(029602)	01-9010-0-0000-3140-3202-834-0082	OTHER RESTRICTE,PERS:C	DR	24.00
(029573)	01-9010-0-0000-3140-3312-831-0082	OTHER RESTRICTE,FICA:CL	DR	1.00
(029583)	01-9010-0-0000-3140-3312-832-0082	OTHER RESTRICTE,FICA:CL	DR	260.00
(029593)	01-9010-0-0000-3140-3312-833-0082	OTHER RESTRICTE,FICA:CL	CR	3.00
(029603)	01-9010-0-0000-3140-3312-834-0082	OTHER RESTRICTE,FICA:CL	CR	8.00
(029613)	01-9010-0-0000-3140-3312-835-0082	OTHER RESTRICTE,FICA:CL	DR	158.00
(029574)	01-9010-0-0000-3140-3332-831-0082	OTHER RESTRICTE,MEDICA	DR	1.00
(029584)	01-9010-0-0000-3140-3332-832-0082	OTHER RESTRICTE,MEDICA	DR	62.00
(029594)	01-9010-0-0000-3140-3332-833-0082	OTHER RESTRICTE,MEDICA	CR	1.00
(029604)	01-9010-0-0000-3140-3332-834-0082	OTHER RESTRICTE,MEDICA	CR	1.00
(029614)	01-9010-0-0000-3140-3332-835-0082	OTHER RESTRICTE,MEDICA	DR	37.00
(029586)	01-9010-0-0000-3140-3502-832-0082	OTHER RESTRICTE,STATE I	DR	21.00
(029616)	01-9010-0-0000-3140-3502-835-0082	OTHER RESTRICTE,STATE I	DR	13.00
(029577)	01-9010-0-0000-3140-3602-831-0082	OTHER RESTRICTE,WORKE	DR	2.00
(029587)	01-9010-0-0000-3140-3602-832-0082	OTHER RESTRICTE,WORKE	DR	86.00
(029597)	01-9010-0-0000-3140-3602-833-0082	OTHER RESTRICTE,WORKE	DR	2.00
(029607)	01-9010-0-0000-3140-3602-834-0082	OTHER RESTRICTE,WORKE	DR	1.00
(029617)	01-9010-0-0000-3140-3602-835-0082	OTHER RESTRICTE,WORKE	DR	52.00
(029860)	01-9010-0-0000-7400-2300-830-0082	OTHER RESTRICTE,CLASS:I	CR	17,456.00
(032179)	01-9010-0-0000-7400-2330-830-0082	OTHER RESTRICTE,CLASS I	CR	1,853.00
(031681)	01-9010-0-0000-7400-2430-830-0082	OTHER RESTRICTE,CLASS I	CR	58.00
(029864)	01-9010-0-0000-7400-3202-830-0082	OTHER RESTRICTE,PERS:C	CR	3,710.00
(029865)	01-9010-0-0000-7400-3312-830-0082	OTHER RESTRICTE,FICA:CL	CR	1,161.00
(029866)	01-9010-0-0000-7400-3332-830-0082	OTHER RESTRICTE,MEDICA	CR	272.00
(029867)	01-9010-0-0000-7400-3402-830-0082	OTHER RESTRICTE,HEALTH	CR	3,565.00
(029868)	01-9010-0-0000-7400-3502-830-0082	OTHER RESTRICTE,STATE I	CR	94.00
(029869)	01-9010-0-0000-7400-3602-830-0082	OTHER RESTRICTE,WORKE	CR	359.00

Selection Grouped by Org, Fiscal Year, JE# - Sorted by JE Item #, (Org = 14, JE Type = R, Starting Post Date = 6/1/2022, Ending Post Date = 7/31/2022, Unposted JEs? = N, End Bud Bal? = O, JE# Page Break? = N, Description? = A, Recap? = N)

ESCAPE ONLINE

Page 63 of 88

Effective 04/14/2022 through 07/29/2022

Fiscal Year 2022

Account	Description	Comment	From	To
(continued) JE # BR22-01765 JE Trans Date 06/30/2022 JE Posted 07/25/2022 Comment BL-3rd interim				
(031020) 01- 9010- 0- 0000- 7400- 4300- 830- 0082	OTHER RESTRICTE,MATERI	CR		1.00
(029527) 01- 9010- 0- 1110- 1000- 4399- 030- 0082	OTHER RESTRICTE,HOLDIN	DR	22,153.00	
			28,847.00	28,847.00

JE # BR22-01766 JE Trans Date 06/30/2022 JE Posted 07/25/2022 Comment BL-3rd interim				
(015347) 01- 0808- 0- 0000- 2420- 2200- 823- 0808	Measure U,CLASS:SUPPORT	CR		1.00
(015357) 01- 0808- 0- 0000- 2420- 2200- 824- 0808	Measure U,CLASS:SUPPORT	CR		729.00
(015367) 01- 0808- 0- 0000- 2420- 2200- 827- 0808	Measure U,CLASS:SUPPORT	CR		46.00
(015351) 01- 0808- 0- 0000- 2420- 3202- 823- 0808	Measure U,PERS:CLASSIFIEI	DR	1.00	
(015361) 01- 0808- 0- 0000- 2420- 3202- 824- 0808	Measure U,PERS:CLASSIFIEI	CR		167.00
(015371) 01- 0808- 0- 0000- 2420- 3202- 827- 0808	Measure U,PERS:CLASSIFIEI	CR		11.00
(015342) 01- 0808- 0- 0000- 2420- 3312- 821- 0808	Measure U,FICA:CLASS,INST	DR	1.00	
(015362) 01- 0808- 0- 0000- 2420- 3312- 824- 0808	Measure U,FICA:CLASS,INST	CR		45.00
(015372) 01- 0808- 0- 0000- 2420- 3312- 827- 0808	Measure U,FICA:CLASS,INST	CR		2.00
(015353) 01- 0808- 0- 0000- 2420- 3332- 823- 0808	Measure U,MEDICARE:CLAS:	DR	1.00	
(015363) 01- 0808- 0- 0000- 2420- 3332- 824- 0808	Measure U,MEDICARE:CLAS:	CR		10.00
(015373) 01- 0808- 0- 0000- 2420- 3332- 827- 0808	Measure U,MEDICARE:CLAS:	DR	1.00	
(015345) 01- 0808- 0- 0000- 2420- 3502- 821- 0808	Measure U,STATE UNEMPLC	DR	1.00	
(015365) 01- 0808- 0- 0000- 2420- 3502- 824- 0808	Measure U,STATE UNEMPLC	CR		4.00
(015346) 01- 0808- 0- 0000- 2420- 3602- 821- 0808	Measure U,WORKERS' COMF	DR	1.00	
(015366) 01- 0808- 0- 0000- 2420- 3602- 824- 0808	Measure U,WORKERS' COMF	CR		14.00
(019296) 01- 0808- 0- 0000- 3110- 1200- 821- 0808	Measure U,CERT:PUPIL SUP	CR		98.00
(019306) 01- 0808- 0- 0000- 3110- 1200- 823- 0808	Measure U,CERT:PUPIL SUP	CR		147.00
(019316) 01- 0808- 0- 0000- 3110- 1200- 824- 0808	Measure U,CERT:PUPIL SUP	CR		129.00
(019326) 01- 0808- 0- 0000- 3110- 1200- 827- 0808	Measure U,CERT:PUPIL SUP	CR		103.00
(019297) 01- 0808- 0- 0000- 3110- 3101- 821- 0808	Measure U,STRS:CERT,GUID	DR	1.00	
(019307) 01- 0808- 0- 0000- 3110- 3101- 823- 0808	Measure U,STRS:CERT,GUID	CR		12.00
(019317) 01- 0808- 0- 0000- 3110- 3101- 824- 0808	Measure U,STRS:CERT,GUID	CR		10.00
(019327) 01- 0808- 0- 0000- 3110- 3101- 827- 0808	Measure U,STRS:CERT,GUID	DR	1.00	
(019312) 01- 0808- 0- 0000- 3110- 3331- 823- 0808	Measure U,MEDICARE:CERT	CR		1.00
(019322) 01- 0808- 0- 0000- 3110- 3331- 824- 0808	Measure U,MEDICARE:CERT	CR		1.00
(019332) 01- 0808- 0- 0000- 3110- 3331- 827- 0808	Measure U,MEDICARE:CERT	CR		1.00
(019303) 01- 0808- 0- 0000- 3110- 3401- 821- 0808	Measure U,HEALTH & WELF/	DR	1.00	
(019304) 01- 0808- 0- 0000- 3110- 3501- 821- 0808	Measure U,STATE UNEMPLC	CR		1.00
(019334) 01- 0808- 0- 0000- 3110- 3501- 827- 0808	Measure U,STATE UNEMPLC	DR	1.00	
(019305) 01- 0808- 0- 0000- 3110- 3601- 821- 0808	Measure U,WORKERS' COMF	CR		1.00
(019315) 01- 0808- 0- 0000- 3110- 3601- 823- 0808	Measure U,WORKERS' COMF	CR		2.00

Selection Grouped by Org, Fiscal Year, JE# - Sorted by JE Item #, (Org = 14, JE Type = R, Starting Post Date = 6/1/2022, Ending Post Date = 7/31/2022, Unposted JEs? = N, End Bud Bal? = O, JE# Page Break? = N, Description? = A, Recap? = N)

ESCAPE ONLINE

Page 64 of 88

Effective 04/14/2022 through 07/29/2022

Fiscal Year 2022

Account		Description	Comment	From	To
(continued)	JE # BR22-01766	JE Trans Date 06/30/2022	JE Posted 07/25/2022	Comment BL-3rd interim	
(019325)	01-0808-0-0000-3110-3601-824-0808	Measure U,WORKERS' COMF	CR		1.00
(019335)	01-0808-0-0000-3110-3601-827-0808	Measure U,WORKERS' COMF	CR		1.00
(015164)	01-0808-0-1110-2420-1200-821-0808	Measure U,CERT:PUPIL SUP	CR		160.00
(015170)	01-0808-0-1110-2420-1200-823-0808	Measure U,CERT:PUPIL SUP	CR		155.00
(015176)	01-0808-0-1110-2420-1200-824-0808	Measure U,CERT:PUPIL SUP	CR		148.00
(015182)	01-0808-0-1110-2420-1200-827-0808	Measure U,CERT:PUPIL SUP	CR		168.00
(017173)	01-0808-0-1110-2420-1240-821-0808	Measure U,CERT PUPIL SUP	DR	2,237.00	
(016553)	01-0808-0-1110-2420-1240-823-0808	Measure U,CERT PUPIL SUP	DR	2,003.00	
(017114)	01-0808-0-1110-2420-1240-824-0808	Measure U,CERT PUPIL SUP	DR	1,526.00	
(016557)	01-0808-0-1110-2420-1240-827-0808	Measure U,CERT PUPIL SUP	DR	2,339.00	
(015165)	01-0808-0-1110-2420-3101-821-0808	Measure U,STRS:CERT,INST	CR		13.00
(015171)	01-0808-0-1110-2420-3101-823-0808	Measure U,STRS:CERT,INST	CR		63.00
(015177)	01-0808-0-1110-2420-3101-824-0808	Measure U,STRS:CERT,INST	DR	833.00	
(015183)	01-0808-0-1110-2420-3101-827-0808	Measure U,STRS:CERT,INST	CR		13.00
(015187)	01-0808-0-1110-2420-3311-827-0808	Measure U,FICA:CERT,INSTF	CR		18.00
(015013)	01-0808-0-1110-2420-3331-821-0808	Measure U,MEDICARE:CERT	CR		2.00
(015014)	01-0808-0-1110-2420-3331-823-0808	Measure U,MEDICARE:CERT	CR		7.00
(015015)	01-0808-0-1110-2420-3331-824-0808	Measure U,MEDICARE:CERT	DR	148.00	
(015016)	01-0808-0-1110-2420-3331-827-0808	Measure U,MEDICARE:CERT	DR	39.00	
(015026)	01-0808-0-1110-2420-3501-823-0808	Measure U,STATE UNEMPLC	CR		2.00
(015027)	01-0808-0-1110-2420-3501-824-0808	Measure U,STATE UNEMPLC	DR	782.00	
(015028)	01-0808-0-1110-2420-3501-827-0808	Measure U,STATE UNEMPLC	CR		3.00
(015031)	01-0808-0-1110-2420-3601-821-0808	Measure U,WORKERS' COMF	CR		2.00
(015032)	01-0808-0-1110-2420-3601-823-0808	Measure U,WORKERS' COMF	CR		7.00
(015033)	01-0808-0-1110-2420-3601-824-0808	Measure U,WORKERS' COMF	DR	281.00	
(015034)	01-0808-0-1110-2420-3601-827-0808	Measure U,WORKERS' COMF	CR		7.00
(015048)	01-0808-0-1120-1000-4300-821-0808	Measure U,MATERIALS & SU	DR	7.00	
(015049)	01-0808-0-1120-1000-4300-823-0808	Measure U,MATERIALS & SU	DR	45.00	
(015050)	01-0808-0-1120-1000-4300-824-0808	Measure U,MATERIALS & SU	DR	192.00	
(015051)	01-0808-0-1120-1000-4300-827-0808	Measure U,MATERIALS & SU	DR	1,800.00	
(031657)	01-0808-0-1150-1000-1140-827-0808	Measure U,CERT SALARY:SL	CR		525.00
(015063)	01-0808-0-1150-1000-1160-821-0808	Measure U,CERT SALARY:S1	DR	694.00	
(015053)	01-0808-0-1150-1000-1160-823-0808	Measure U,CERT SALARY:S1	CR		439.00
(015073)	01-0808-0-1150-1000-1160-824-0808	Measure U,CERT SALARY:S1	DR	1,448.00	
(015083)	01-0808-0-1150-1000-1160-827-0808	Measure U,CERT SALARY:S1	CR		78.00
(015064)	01-0808-0-1150-1000-3101-821-0808	Measure U,STRS:CERT,INST	DR	117.00	
(015054)	01-0808-0-1150-1000-3101-823-0808	Measure U,STRS:CERT,INST	CR		75.00

Selection Grouped by Org, Fiscal Year, JE# - Sorted by JE Item #, (Org = 14, JE Type = R, Starting Post Date = 6/1/2022, Ending Post Date = 7/31/2022, Unposted JEs? = N, End Bud Bal? = O, JE# Page Break? = N, Description? = A, Recap? = N)

ESCAPE ONLINE

Page 65 of 88

Effective 04/14/2022 through 07/29/2022

Fiscal Year 2022

Account		Description	Comment	From	To
(continued)	JE # BR22-01766	JE Trans Date 06/30/2022	JE Posted 07/25/2022	Comment BL-3rd interim	
(015074)	01-0808-0-1150-1000-3101-824-0808	Measure U,STRS:CERT,INST	DR	245.00	
(015084)	01-0808-0-1150-1000-3101-827-0808	Measure U,STRS:CERT,INST	CR		90.00
(015088)	01-0808-0-1150-1000-3311-827-0808	Measure U,FICA:CERT,INSTF	CR		5.00
(015069)	01-0808-0-1150-1000-3331-821-0808	Measure U,MEDICARE:CERT	DR	10.00	
(015059)	01-0808-0-1150-1000-3331-823-0808	Measure U,MEDICARE:CERT	CR		7.00
(015079)	01-0808-0-1150-1000-3331-824-0808	Measure U,MEDICARE:CERT	DR	21.00	
(015089)	01-0808-0-1150-1000-3331-827-0808	Measure U,MEDICARE:CERT	CR		9.00
(015071)	01-0808-0-1150-1000-3501-821-0808	Measure U,STATE UNEMPLC	DR	19.00	
(015061)	01-0808-0-1150-1000-3501-823-0808	Measure U,STATE UNEMPLC	DR	13.00	
(015081)	01-0808-0-1150-1000-3501-824-0808	Measure U,STATE UNEMPLC	DR	23.00	
(015091)	01-0808-0-1150-1000-3501-827-0808	Measure U,STATE UNEMPLC	DR	18.00	
(015072)	01-0808-0-1150-1000-3601-821-0808	Measure U,WORKERS' COMF	DR	15.00	
(015062)	01-0808-0-1150-1000-3601-823-0808	Measure U,WORKERS' COMF	CR		7.00
(015082)	01-0808-0-1150-1000-3601-824-0808	Measure U,WORKERS' COMF	DR	29.00	
(015092)	01-0808-0-1150-1000-3601-827-0808	Measure U,WORKERS' COMF	CR		9.00
(015113)	01-0808-0-1540-1000-2100-821-0808	Measure U,CLASS:INSTRUC	CR		1.00
(015123)	01-0808-0-1540-1000-2100-823-0808	Measure U,CLASS:INSTRUC	DR	1.00	
(015143)	01-0808-0-1540-1000-2100-827-0808	Measure U,CLASS:INSTRUC	CR		10.00
(015137)	01-0808-0-1540-1000-3202-824-0808	Measure U,PERS:CLASSIFIEI	DR	1.00	
(015147)	01-0808-0-1540-1000-3202-827-0808	Measure U,PERS:CLASSIFIEI	CR		2.00
(015118)	01-0808-0-1540-1000-3312-821-0808	Measure U,FICA:CLASS,INST	DR	57.00	
(015128)	01-0808-0-1540-1000-3312-823-0808	Measure U,FICA:CLASS,INST	DR	1.00	
(015148)	01-0808-0-1540-1000-3312-827-0808	Measure U,FICA:CLASS,INST	CR		1.00
(015119)	01-0808-0-1540-1000-3332-821-0808	Measure U,MEDICARE:CLAS	DR	13.00	
(015129)	01-0808-0-1540-1000-3332-823-0808	Measure U,MEDICARE:CLAS	DR	1.00	
(015139)	01-0808-0-1540-1000-3332-824-0808	Measure U,MEDICARE:CLAS	DR	1.00	
(015149)	01-0808-0-1540-1000-3332-827-0808	Measure U,MEDICARE:CLAS	DR	1.00	
(015121)	01-0808-0-1540-1000-3502-821-0808	Measure U,STATE UNEMPLC	DR	6.00	
(015122)	01-0808-0-1540-1000-3602-821-0808	Measure U,WORKERS' COMF	DR	1.00	
(015132)	01-0808-0-1540-1000-3602-823-0808	Measure U,WORKERS' COMF	DR	1.00	
(015142)	01-0808-0-1540-1000-3602-824-0808	Measure U,WORKERS' COMF	DR	1.00	
(017118)	01-0808-0-3100-1000-2130-825-0808	Measure U,CLASS INSTR AIC	DR	248.00	
(017123)	01-0808-0-3100-1000-3312-825-0808	Measure U,FICA:CLASS,INST	DR	310.00	
(017124)	01-0808-0-3100-1000-3332-825-0808	Measure U,MEDICARE:CLAS	DR	4.00	
(017126)	01-0808-0-3100-1000-3502-825-0808	Measure U,STATE UNEMPLC	DR	38.00	
(017127)	01-0808-0-3100-1000-3602-825-0808	Measure U,WORKERS' COMF	DR	8.00	
(015201)	01-0808-0-1110-1000-4399-520-0808	Measure U,HOLDING ACCOL	CR		12,024.00

Selection Grouped by Org, Fiscal Year, JE# - Sorted by JE Item #, (Org = 14, JE Type = R, Starting Post Date = 6/1/2022, Ending Post Date = 7/31/2022, Unposted JEs? = N, End Bud Bal? = O, JE# Page Break? = N, Description? = A, Recap? = N)

ESCAPE ONLINE

Page 66 of 88

Effective 04/14/2022 through 07/29/2022

Fiscal Year 2022

Account	Description	Comment	From	To
			15,587.00	15,587.00
JE # BR22-01767 JE Trans Date 06/30/2022 JE Posted 07/25/2022 Comment BL-3rd interim				
(019324) 01-0808-0-0000-3110-3501-824-0808	Measure U,STATE UNEMPLC			1.00
(015201) 01-0808-0-1110-1000-4399-520-0808	Measure U,HOLDING ACCOL		1.00	
			1.00	1.00
JE # BR22-01768 JE Trans Date 06/30/2022 JE Posted 07/29/2022 Comment BL-DU89284 SCCOE BUS COST D.GUTIERREZ INV22-013				
(032387) 01-0723-0-0000-3600-2290-848-0080	TRANSPORT:HOME,CLASS I			2,150.00
(032233) 01-0723-0-0000-0000-8699-848-0080	TRANSPORT:HOME,ALL OTI			2,150.00
Net increase to Appropriations			.00	4,300.00
JE # BR22-01769 JE Trans Date 06/30/2022 JE Posted 07/29/2022 Comment BL-3rd interim				
(011787) 01-0000-0-0000-2700-1340-821-0000	NO REPORTING RE,CERT S		10,601.00	
(000381) 01-0000-0-0000-2700-2440-821-0000	NO REPORTING RE,CLASS C		963.00	
(027973) 01-0000-0-0000-3160-2930-821-0000	NO REPORTING RE,OTHER		576.00	
(001350) 01-0000-0-0000-8200-2240-823-0000	NO REPORTING RE,CLASS I		1,416.00	
(001352) 01-0000-0-0000-8200-2240-827-0000	NO REPORTING RE,CLASS I		618.00	
(013747) 01-0000-0-0000-8300-2940-823-0000	NO REPORTING RE,OTHER		1,180.00	
(028445) 01-0000-0-1110-1000-2140-821-0000	NO REPORTING RE,CLASS I		1,451.00	
(002736) 01-0000-0-3100-1000-1100-825-0000	NO REPORTING RE,CERT:TI			556.00
(002738) 01-0000-0-3100-1000-1140-825-0000	NO REPORTING RE,CERT S.			1,871.00
(002742) 01-0000-0-3100-1000-3101-825-0000	NO REPORTING RE,STRS:C			300.00
(002749) 01-0000-0-3100-1000-3331-825-0000	NO REPORTING RE,MEDICA		86.00	
(002755) 01-0000-0-3100-1000-3501-825-0000	NO REPORTING RE,STATE I		153.00	
(002759) 01-0000-0-3100-1000-3601-825-0000	NO REPORTING RE,WORKE			35.00
(002765) 01-0000-0-3100-1000-4300-825-0000	NO REPORTING RE,MATERI		1,200.00	
Net decrease to Appropriations			18,244.00	2,762.00
JE # BR22-01770 JE Trans Date 06/30/2022 JE Posted 07/29/2022 Comment BL-3rd interim				
(000906) 01-0000-0-0000-3140-2240-831-0000	NO REPORTING RE,CLASS I		289.00	
(001353) 01-0000-0-0000-8200-2240-831-0000	NO REPORTING RE,CLASS I		384.00	
Net decrease to Appropriations			673.00	.00

Selection Grouped by Org, Fiscal Year, JE# - Sorted by JE Item #, (Org = 14, JE Type = R, Starting Post Date = 6/1/2022, Ending Post Date = 7/31/2022, Unposted JEs? = N, End Bud Bal? = O, JE# Page Break? = N, Description? = A, Recap? = N)

ESCAPE ONLINE

Page 67 of 88

Effective 04/14/2022 through 07/29/2022

Fiscal Year 2022

Account		Description	Comment	From	To
JE #	BR22-01771	JE Trans Date 06/30/2022	JE Posted 07/29/2022	Comment BL-3rd interim	
(015377)	01-0808-0-0000-2420-2200-831-0808	Measure U,CLASS:SUPPORT		CR	1.00
(015381)	01-0808-0-0000-2420-3202-831-0808	Measure U,PERS:CLASSIFIE		CR	83.00
(015382)	01-0808-0-0000-2420-3312-831-0808	Measure U,FICA:CLASS,INST		CR	22.00
(015383)	01-0808-0-0000-2420-3332-831-0808	Measure U,MEDICARE:CLAS		CR	5.00
(015385)	01-0808-0-0000-2420-3502-831-0808	Measure U,STATE UNEMPLC		CR	1.00
(015386)	01-0808-0-0000-2420-3602-831-0808	Measure U,WORKERS' COMF		CR	6.00
(019223)	01-0808-0-0000-2495-2200-831-0808	Measure U,CLASS:SUPPORT		CR	889.00
(019228)	01-0808-0-0000-2495-3312-831-0808	Measure U,FICA:CLASS,PAR		CR	54.00
(019229)	01-0808-0-0000-2495-3332-831-0808	Measure U,MEDICARE:CLAS		CR	12.00
(019232)	01-0808-0-0000-2495-3602-831-0808	Measure U,WORKERS' COMF		CR	16.00
(015398)	01-0808-0-0000-3110-1200-831-0808	Measure U,CERT:PUPIL SUP		CR	170.00
(015399)	01-0808-0-0000-3110-3101-831-0808	Measure U,STRS:CERT,GUID		CR	14.00
(015404)	01-0808-0-0000-3110-3331-831-0808	Measure U,MEDICARE:CERT		CR	2.00
(015407)	01-0808-0-0000-3110-3601-831-0808	Measure U,WORKERS' COMF		CR	1.00
(022933)	01-0808-0-1110-1000-2130-831-0808	Measure U,CLASS INSTR AIC		DR	144.00
(020918)	01-0808-0-1110-1000-3102-831-0808	Measure U,STRS:CLASSIFIE		DR	203.00
(020920)	01-0808-0-1110-1000-3202-831-0808	Measure U,PERS:CLASSIFIE		DR	413.00
(022934)	01-0808-0-1110-1000-3312-831-0808	Measure U,FICA:CLASS,INST		DR	9.00
(022935)	01-0808-0-1110-1000-3332-831-0808	Measure U,MEDICARE:CLAS		DR	1.00
(022938)	01-0808-0-1110-1000-3602-831-0808	Measure U,WORKERS' COMF		DR	4.00
(025228)	01-0808-0-1110-1000-4300-831-0808	Measure U,MATERIALS & SU		DR	5,167.00
(015188)	01-0808-0-1110-2420-1200-831-0808	Measure U,CERT:PUPIL SUP		CR	163.00
(016546)	01-0808-0-1110-2420-1240-831-0808	Measure U,CERT PUPIL SUP		DR	1,634.00
(015189)	01-0808-0-1110-2420-3101-831-0808	Measure U,STRS:CERT,INST		CR	14.00
(015017)	01-0808-0-1110-2420-3331-831-0808	Measure U,MEDICARE:CERT		CR	2.00
(015029)	01-0808-0-1110-2420-3501-831-0808	Measure U,STATE UNEMPLC		CR	1.00
(015035)	01-0808-0-1110-2420-3601-831-0808	Measure U,WORKERS' COMF		DR	2.00
(021178)	01-0808-0-1120-1000-1100-831-0808	Measure U,CERT:TEACHERS		DR	66.00
(025839)	01-0808-0-1120-1000-1140-831-0808	Measure U,CERT SALARY:SU		CR	147.00
(023685)	01-0808-0-1120-1000-2130-831-0808	Measure U,CLASS INSTR AIC		DR	1,656.00
(021179)	01-0808-0-1120-1000-3101-831-0808	Measure U,STRS:CERT,INST		CR	50.00
(021180)	01-0808-0-1120-1000-3102-831-0808	Measure U,STRS:CLASSIFIE		DR	145.00
(023686)	01-0808-0-1120-1000-3312-831-0808	Measure U,FICA:CLASS,INST		DR	47.00
(021184)	01-0808-0-1120-1000-3331-831-0808	Measure U,MEDICARE:CERT		CR	4.00
(023687)	01-0808-0-1120-1000-3332-831-0808	Measure U,MEDICARE:CLAS		DR	25.00
(021186)	01-0808-0-1120-1000-3501-831-0808	Measure U,STATE UNEMPLC		CR	1.00
(023689)	01-0808-0-1120-1000-3502-831-0808	Measure U,STATE UNEMPLC		DR	21.00

Selection Grouped by Org, Fiscal Year, JE# - Sorted by JE Item #, (Org = 14, JE Type = R, Starting Post Date = 6/1/2022, Ending Post Date = 7/31/2022, Unposted JEs? = N, End Bud Bal? = O, JE# Page Break? = N, Description? = A, Recap? = N)

ESCAPE ONLINE

Page 68 of 88

Effective 04/14/2022 through 07/29/2022

Fiscal Year 2022

Account		Description	Comment	From	To
(continued)	JE # BR22-01771	JE Trans Date 06/30/2022	JE Posted 07/29/2022	Comment BL-3rd interim	
(021187)	01-0808-0-1120-1000-3601-831-0808	Measure U,WORKERS' COMF	CR		4.00
(023690)	01-0808-0-1120-1000-3602-831-0808	Measure U,WORKERS' COMF	DR	34.00	
(022923)	01-0808-0-1130-1000-2130-831-0808	Measure U,CLASS INSTR AIC	DR	1,116.00	
(022928)	01-0808-0-1130-1000-3312-831-0808	Measure U,FICA:CLASS,INST	DR	70.00	
(022929)	01-0808-0-1130-1000-3332-831-0808	Measure U,MEDICARE:CLAS	DR	17.00	
(022931)	01-0808-0-1130-1000-3502-831-0808	Measure U,STATE UNEMPLC	DR	24.00	
(022932)	01-0808-0-1130-1000-3602-831-0808	Measure U,WORKERS' COMF	DR	23.00	
(016560)	01-0808-0-1250-1000-1140-831-0808	Measure U,CERT SALARY:SU	CR		90.00
(023728)	01-0808-0-1250-1000-2130-831-0808	Measure U,CLASS INSTR AIC	CR		144.00
(023729)	01-0808-0-1250-1000-3312-831-0808	Measure U,FICA:CLASS,INST	CR		9.00
(015099)	01-0808-0-1250-1000-3331-831-0808	Measure U,MEDICARE:CERT	CR		1.00
(023730)	01-0808-0-1250-1000-3332-831-0808	Measure U,MEDICARE:CLAS	CR		1.00
(015101)	01-0808-0-1250-1000-3501-831-0808	Measure U,STATE UNEMPLC	CR		1.00
(023732)	01-0808-0-1250-1000-3502-831-0808	Measure U,STATE UNEMPLC	DR	12.00	
(015102)	01-0808-0-1250-1000-3601-831-0808	Measure U,WORKERS' COMF	CR		1.00
(022939)	01-0808-0-1260-1000-2130-831-0808	Measure U,CLASS INSTR AIC	DR	288.00	
(022944)	01-0808-0-1260-1000-3312-831-0808	Measure U,FICA:CLASS,INST	DR	18.00	
(022945)	01-0808-0-1260-1000-3332-831-0808	Measure U,MEDICARE:CLAS	DR	5.00	
(022947)	01-0808-0-1260-1000-3502-831-0808	Measure U,STATE UNEMPLC	DR	14.00	
(022948)	01-0808-0-1260-1000-3602-831-0808	Measure U,WORKERS' COMF	DR	7.00	
(029771)	01-0808-0-1380-4100-2160-831-0808	Measure U,CLASS INSTR AIC	CR		23.00
(025804)	01-0808-0-1380-4100-3101-831-0808	Measure U,STRS:CERT,SCH	DR	354.00	
(025808)	01-0808-0-1380-4100-3311-831-0808	Measure U,FICA:CERT,SCHC	CR		130.00
(029772)	01-0808-0-1380-4100-3312-831-0808	Measure U,FICA:CLASS,SCH	CR		2.00
(029776)	01-0808-0-1380-4100-3602-831-0808	Measure U,WORKERS' COMF	CR		1.00
(019240)	01-0808-0-1400-4200-1160-831-0808	Measure U,CERT SALARY:ST	CR		1,153.00
(019250)	01-0808-0-1400-4200-2160-831-0808	Measure U,CLASS INSTR AIC	DR	1,420.00	
(019241)	01-0808-0-1400-4200-3101-831-0808	Measure U,STRS:CERT,SCH	DR	1,759.00	
(019242)	01-0808-0-1400-4200-3102-831-0808	Measure U,STRS:CLASSIFIEI	CR		196.00
(019245)	01-0808-0-1400-4200-3311-831-0808	Measure U,FICA:CERT,SCHC	CR		13.00
(019251)	01-0808-0-1400-4200-3312-831-0808	Measure U,FICA:CLASS,SCH	DR	233.00	
(019246)	01-0808-0-1400-4200-3331-831-0808	Measure U,MEDICARE:CERT	CR		20.00
(019252)	01-0808-0-1400-4200-3332-831-0808	Measure U,MEDICARE:CLAS	DR	20.00	
(019248)	01-0808-0-1400-4200-3501-831-0808	Measure U,STATE UNEMPLC	DR	49.00	
(019254)	01-0808-0-1400-4200-3502-831-0808	Measure U,STATE UNEMPLC	DR	185.00	
(019249)	01-0808-0-1400-4200-3601-831-0808	Measure U,WORKERS' COMF	CR		21.00
(019255)	01-0808-0-1400-4200-3602-831-0808	Measure U,WORKERS' COMF	DR	48.00	

Selection Grouped by Org, Fiscal Year, JE# - Sorted by JE Item #, (Org = 14, JE Type = R, Starting Post Date = 6/1/2022, Ending Post Date = 7/31/2022, Unposted JEs? = N, End Bud Bal? = O, JE# Page Break? = N, Description? = A, Recap? = N)

ESCAPE ONLINE

Page 69 of 88

Effective 04/14/2022 through 07/29/2022

Fiscal Year 2022

Account		Description	Comment	From	To
(continued)	JE # BR22-01771	JE Trans Date 06/30/2022	JE Posted 07/29/2022	Comment BL-3rd interim	
(027785)	01-0808-0-1450-1000-2130-831-0808	Measure U,CLASS INSTR AIC	DR	828.00	
(027790)	01-0808-0-1450-1000-3312-831-0808	Measure U,FICA:CLASS,INST	CR		44.00
(027791)	01-0808-0-1450-1000-3332-831-0808	Measure U,MEDICARE:CLAS	CR		11.00
(027793)	01-0808-0-1450-1000-3502-831-0808	Measure U,STATE UNEMPLC	CR		4.00
(027794)	01-0808-0-1450-1000-3602-831-0808	Measure U,WORKERS' COMF	CR		14.00
(015419)	01-0808-0-1110-1000-4399-530-0808	Measure U,HOLDING ACCOL	CR		12,520.00
				16,061.00	16,061.00

Effective 04/14/2022 through 07/29/2022

Fiscal Year 2023

Account	Description	Comment	From	To
JE # BR23-00001 JE Trans Date 07/01/2022 JE Posted 06/20/2022 Comment BL-PER ST MOVE FROM 5800 TO 4300-830-0808				
(032150) 01- 0808- 0- 1400- 4200- 4300- 830- 0808	Measure U,MATERIALS & SU		CR	3,500.00
(020426) 01- 0808- 0- 1400- 4200- 5800- 831- 0808	Measure U,PROF/CONSULT :		DR	3,500.00
(032150) 01- 0808- 0- 1400- 4200- 4300- 830- 0808	Measure U,MATERIALS & SU		CR	3,500.00
(020424) 01- 0808- 0- 1400- 4200- 5800- 832- 0808	Measure U,PROF/CONSULT :		DR	3,500.00
			7,000.00	7,000.00
JE # BR23-00002 JE Trans Date 07/01/2022 JE Posted 06/20/2022 Comment BL-FROM 4300 TO 5800				
(032150) 01- 0808- 0- 1400- 4200- 4300- 830- 0808	Measure U,MATERIALS & SU		DR	7,000.00
(032151) 01- 0808- 0- 1400- 4200- 5800- 830- 0808	Measure U,PROF/CONSULT : BL-FROM 4300 TO 5800 FOR ARBITER PAY		CR	7,000.00
			7,000.00	7,000.00
JE # BR23-00003 JE Trans Date 07/01/2022 JE Posted 06/21/2022 Comment IB DIPLOMA FEE				
(020626) 01- 0000- 0- 0000- 2700- 5800- 033- 3390	NO REPORTING RE,PROF/C		CR	11,650.00
(016614) 01- 0000- 0- 1110- 1000- 4300- 033- 3390	NO REPORTING RE,MATERI		DR	11,650.00
			11,650.00	11,650.00
JE # BR23-00004 JE Trans Date 07/01/2022 JE Posted 06/21/2022 Comment CSA-ORGANIZED BINDER				
(032153) 01- 3010- 0- 1110- 2140- 5800- 533- 0000	BAS GNT LOW-INC,PROF/CC		CR	5,500.00
(024390) 01- 3010- 0- 1110- 1000- 4300- 533- 0000	BAS GNT LOW-INC,MATERI/		DR	5,500.00
			5,500.00	5,500.00
JE # BR23-00005 JE Trans Date 07/01/2022 JE Posted 06/21/2022 Comment CSA-TURNITIN				
(003680) 01- 0700- 0- 1110- 1000- 5800- 033- 0000	LCFF SUPP FUNDI,PROF/CC		CR	4,820.00
(003646) 01- 0700- 0- 1110- 1000- 4300- 033- 0000	LCFF SUPP FUNDI,MATERIA		DR	4,820.00
			4,820.00	4,820.00
JE # BR23-00006 JE Trans Date 07/01/2022 JE Posted 06/21/2022 Comment PS- PE UNIFORMS				
(003680) 01- 0700- 0- 1110- 1000- 5800- 033- 0000	LCFF SUPP FUNDI,PROF/CC		CR	7,027.00
(003646) 01- 0700- 0- 1110- 1000- 4300- 033- 0000	LCFF SUPP FUNDI,MATERIA		DR	7,027.00
			7,027.00	7,027.00
JE # BR23-00007 JE Trans Date 07/01/2022 JE Posted 06/21/2022 Comment BD- ADVANCE C/O FOR CIA				

Selection Grouped by Org, Fiscal Year, JE# - Sorted by JE Item #, (Org = 14, JE Type = R, Starting Post Date = 6/1/2022, Ending Post Date = 7/31/2022,
Unposted JEs? = N, End Bud Bal? = O, JE# Page Break? = N, Description? = A, Recap? = N)

ESCAPE ONLINE

Page 71 of 88

Effective 04/14/2022 through 07/29/2022

Fiscal Year 2023

Account	Description	Comment	From	To
(continued) JE # BR23-00007 JE Trans Date 07/01/2022 JE Posted 06/21/2022		Comment BD- ADVANCE C/O FOR CIA		
(025933) 01- 3213- 0- 0000- 0000- 8290- 830- 0000	ESSER III ARP,ALL OTHER F	DR		121,550.00
(026753) 01- 3213- 0- 1110- 1000- 5800- 530- 0000	ESSER III ARP,PROF/CONSL	CR		121,550.00
(025932) 01- 3213- 0- 0000- 0000- 8290- 820- 0000	ESSER III ARP,ALL OTHER F	DR		36,462.00
(032156) 01- 3213- 0- 1110- 1000- 5800- 520- 0000	ESSER III ARP,PROF/CONSL	CR		36,462.00
Net increase to Appropriations			.00	316,024.00

JE # BR23-00008 JE Trans Date 07/01/2022 JE Posted 06/21/2022		Comment BD- ADVANCE C/O FOR CIA		
(025933) 01- 3213- 0- 0000- 0000- 8290- 830- 0000	ESSER III ARP,ALL OTHER F	CR	121,550.00	
(026753) 01- 3213- 0- 1110- 1000- 5800- 530- 0000	ESSER III ARP,PROF/CONSL	DR	121,550.00	
(025932) 01- 3213- 0- 0000- 0000- 8290- 820- 0000	ESSER III ARP,ALL OTHER F	CR	36,462.00	
(032156) 01- 3213- 0- 1110- 1000- 5800- 520- 0000	ESSER III ARP,PROF/CONSL	DR	36,462.00	
Net decrease to Appropriations			316,024.00	.00

JE # BR23-00009 JE Trans Date 07/01/2022 JE Posted 06/21/2022		Comment BD- ADVANCE C/O FOR CIA		
(025933) 01- 3213- 0- 0000- 0000- 8290- 830- 0000	ESSER III ARP,ALL OTHER F	DR		73,800.00
(026753) 01- 3213- 0- 1110- 1000- 5800- 530- 0000	ESSER III ARP,PROF/CONSL	CR		73,800.00
(025932) 01- 3213- 0- 0000- 0000- 8290- 820- 0000	ESSER III ARP,ALL OTHER F	DR		84,212.00
(032156) 01- 3213- 0- 1110- 1000- 5800- 520- 0000	ESSER III ARP,PROF/CONSL	CR		84,212.00
Net increase to Appropriations			.00	316,024.00

JE # BR23-00010 JE Trans Date 07/01/2022 JE Posted 06/21/2022		Comment BD-ACHIEVE 3000 LICENSE		
(032157) 01- 4203- 0- 1195- 1000- 5800- 534- 0000	ESEA:ENGLISH LE,PROF/CC	CR		3,170.00
(032158) 01- 4203- 0- 1195- 1000- 5800- 531- 0000	ESEA:ENGLISH LE,PROF/CC	CR		4,065.00
(032159) 01- 4203- 0- 1195- 1000- 5800- 532- 0000	ESEA:ENGLISH LE,PROF/CC	CR		2,690.00
(024133) 01- 4203- 0- 1110- 1000- 4399- 530- 0000	ESEA:ENGLISH LE,HOLDING	DR	9,925.00	
			9,925.00	9,925.00

JE # BR23-00011 JE Trans Date 07/01/2022 JE Posted 06/22/2022		Comment SJ-LAB AIDS LICENSES FOR MHMS		
(006136) 01- 6300- 0- 1110- 1000- 4100- 530- 0000	LOTTERY:INSTRUC,APPR TI	DR	450.00	
(006170) 01- 6300- 0- 1110- 1000- 5800- 532- 0000	LOTTERY:INSTRUC,PROF/C	CR		450.00
			450.00	450.00

JE # BR23-00012 JE Trans Date 07/01/2022 JE Posted 06/22/2022		Comment SJ-NYT SUBSCRIPTION RENEWAL		
--	--	-------------------------------------	--	--

Selection Grouped by Org, Fiscal Year, JE# - Sorted by JE Item #, (Org = 14, JE Type = R, Starting Post Date = 6/1/2022, Ending Post Date = 7/31/2022, Unposted JEs? = N, End Bud Bal? = O, JE# Page Break? = N, Description? = A, Recap? = N)

ESCAPE ONLINE

Page 72 of 88

Effective 04/14/2022 through 07/29/2022

Fiscal Year 2023

Account	Description	Comment	From	To
JE # BR23-00012 JE Trans Date 07/01/2022 JE Posted 06/22/2022 Comment SJ-NYT SUBSCRIPTION RENEWAL				
(continued)				
(006136) 01-6300-0-1110-1000-4100-530-0000	LOTTERY:INSTRUC,APPR TI	DR	2,288.00	
(006168) 01-6300-0-1110-1000-5800-530-0000	LOTTERY:INSTRUC,PROF/C	CR		2,288.00
			2,288.00	2,288.00
JE # BR23-00013 JE Trans Date 07/01/2022 JE Posted 06/22/2022 Comment SJ-YOUR SUTURE IS OUR BUSINESS AGREEMENT				
(024152) 01-6387-0-6000-1000-4300-530-0000	CAREER TECHNICA,MATER	DR	25,000.00	
(024155) 01-6387-0-6000-1000-5800-530-0000	CAREER TECHNICA,PROF/C	CR		25,000.00
			25,000.00	25,000.00
JE # BR23-00014 JE Trans Date 07/01/2022 JE Posted 06/22/2022 Comment SJ-NEWSELA CONTRACT RENEWAL				
(006136) 01-6300-0-1110-1000-4100-530-0000	LOTTERY:INSTRUC,APPR TI	DR	53,500.00	
(006168) 01-6300-0-1110-1000-5800-530-0000	LOTTERY:INSTRUC,PROF/C	CR		53,500.00
			53,500.00	53,500.00
JE # BR23-00015 JE Trans Date 07/01/2022 JE Posted 06/22/2022 Comment LAB-AIDS LICENSES FOR MHMS				
(006136) 01-6300-0-1110-1000-4100-530-0000	LOTTERY:INSTRUC,APPR TI	DR	450.00	
(006170) 01-6300-0-1110-1000-5800-532-0000	LOTTERY:INSTRUC,PROF/C	CR		450.00
			450.00	450.00
JE # BR23-00016 JE Trans Date 07/01/2022 JE Posted 06/22/2022 Comment NYT SUBSCRIPTION RENEWAL				
(006119) 01-6300-0-0000-0000-8560-530-0000	LOTTERY:INSTRUC,STATE I	CR	2,288.00	
(006168) 01-6300-0-1110-1000-5800-530-0000	LOTTERY:INSTRUC,PROF/C	CR		2,288.00
			2,288.00	2,288.00
JE # BR23-00017 JE Trans Date 07/01/2022 JE Posted 06/22/2022 Comment BD-ADVANCE C/O WEST ED PD				
(025933) 01-3213-0-0000-0000-8290-830-0000	ESSER III ARP,ALL OTHER F	DR		30,000.00
(032164) 01-3213-0-1195-1000-5800-530-0000	ESSER III ARP,PROF/CONS	CR		30,000.00
(023571) 01-3212-0-0000-0000-8290-830-0000	ESSER II,ALL OTHER FEDEF	DR		50,000.00
(032163) 01-3212-0-1195-1000-5800-530-0000	ESSER II,PROF/CONSULT SI	CR		50,000.00
			.00	160,000.00
Net increase to Appropriations				
JE # BR23-00018 JE Trans Date 07/01/2022 JE Posted 06/24/2022 Comment ML-PALACE				
(000996) 01-0000-0-0000-3140-5800-600-0000	NO REPORTING RE,PROF/C	DR	1,000.00	

Selection Grouped by Org, Fiscal Year, JE# - Sorted by JE Item #, (Org = 14, JE Type = R, Starting Post Date = 6/1/2022, Ending Post Date = 7/31/2022, Unposted JEs? = N, End Bud Bal? = O, JE# Page Break? = N, Description? = A, Recap? = N)

ESCAPE ONLINE

Effective 04/14/2022 through 07/29/2022

Fiscal Year 2023

Account	Description	Comment	From	To
(continued) JE # BR23-00018 JE Trans Date 07/01/2022 JE Posted 06/24/2022	Comment ML-PALACE			
(000993) 01-0000-0-0000-3140-4300-600-0000	NO REPORTING RE,MATERI	CR		1,000.00
			1,000.00	1,000.00
JE # BR23-00019 JE Trans Date 07/01/2022 JE Posted 06/27/2022	Comment BD- ADDING CATAPULT EMS BUDGET			
(001279) 01-0000-0-0000-7600-5800-600-0000	NO REPORTING RE,PROF/C	CR		4,719.00
	Net increase to Appropriations		.00	4,719.00
JE # BR23-00020 JE Trans Date 07/01/2022 JE Posted 06/28/2022	Comment JL-For Kajeet Smartbus Internet			
(032181) 01-0000-0-1110-1000-4400-057-0004	NO REPORTING RE,NON-CA	CR		49,261.00
(001315) 01-0000-0-0000-7700-5900-857-0000	NO REPORTING RE,COMMU	DR	49,261.00	
			49,261.00	49,261.00
JE # BR23-00021 JE Trans Date 07/01/2022 JE Posted 06/28/2022	Comment JL-Move to cover SELF Insurance			
(011747) 01-0000-0-1110-1000-1100-899-9998	NO REPORTING RE,CERT:TI	DR	36,317.00	
(001463) 01-0000-0-0000-8200-5450-899-0000	NO REPORTING RE,OTHER	CR		36,317.00
			36,317.00	36,317.00
JE # BR23-00022 JE Trans Date 07/01/2022 JE Posted 06/29/2022	Comment EB-EDGEWOOD PRESS-DRAGON STUDENT FOLDERS			
(029331) 01-7422-0-1110-1000-4300-823-0000	IPI GF,MATERIALS & SUP,IN	DR	946.00	
(032183) 01-7422-0-1110-1000-5800-823-0000	IPI GF,PROF/CONSULT SE,IF	CR		946.00
			946.00	946.00
JE # BR23-00023 JE Trans Date 07/01/2022 JE Posted 06/29/2022	Comment JL-For Ear Tips			
(029359) 01-6500-0-5760-1190-4300-200-0000	SE:STATE LOCAL,MATERIAL	CR		100.00
(006987) 01-6500-0-5760-1190-5200-220-0000	SE:STATE LOCAL ,TRAVEL &	DR	100.00	
			100.00	100.00
JE # BR23-00024 JE Trans Date 07/01/2022 JE Posted 06/29/2022	Comment JL-Advance C/O for Res 6536			
(029325) 01-6536-0-5001-2700-4300-220-0000	Sped Dispute,MATERIALS &	CR		9,388.00
(032186) 01-6536-0-5001-2700-4300-230-0000	Sped Dispute,MATERIALS &	CR		27,047.00
	Net increase to Appropriations		.00	36,435.00

Selection Grouped by Org, Fiscal Year, JE# - Sorted by JE Item #, (Org = 14, JE Type = R, Starting Post Date = 6/1/2022, Ending Post Date = 7/31/2022, Unposted JEs? = N, End Bud Bal? = O, JE# Page Break? = N, Description? = A, Recap? = N)

ESCAPE ONLINE

Effective 04/14/2022 through 07/29/2022

Fiscal Year 2023

Account	Description	Comment	From	To
JE # BR23-00025 JE Trans Date 07/01/2022 JE Posted 06/30/2022 Comment BD-CORRECTING BUDGET				
(001066) 01- 0000- 0- 0000- 7110- 5800- 053- 0000	NO REPORTING RE,PROF/C	CR		45,250.00
(001063) 01- 0000- 0- 0000- 7110- 5200- 053- 0000	NO REPORTING RE,TRAVEL	CR		7,000.00
(001103) 01- 0000- 0- 0000- 7150- 4395- 053- 0000	NO REPORTING RE,FOOD F	CR		3,000.00
(001109) 01- 0000- 0- 0000- 7150- 5710- 053- 0000	NO REPORTING RE,XFER O	CR		1,500.00
Net increase to Appropriations			.00	56,750.00

JE # BR23-00026 JE Trans Date 07/01/2022 JE Posted 06/30/2022 Comment BD-ADVANCE C/O LEXIA LICENSE				
(024092) 01- 4203- 0- 0000- 0000- 8290- 520- 0000	ESEA:ENGLISH LE,ALL OTHI	DR		35,000.00
(032187) 01- 4203- 0- 1195- 1000- 5800- 520- 0000	ESEA:ENGLISH LE,PROF/CC	CR		35,000.00
Net increase to Appropriations			.00	70,000.00

JE # BR23-00027 JE Trans Date 07/01/2022 JE Posted 07/01/2022 Comment BD- ADVANCE C/O FOR CIA				
(025933) 01- 3213- 0- 0000- 0000- 8290- 830- 0000	ESSER III ARP,ALL OTHER F	CR	73,800.00	
(026753) 01- 3213- 0- 1110- 1000- 5800- 530- 0000	ESSER III ARP,PROF/CONSL	DR	73,800.00	
Net decrease to Appropriations			147,600.00	.00

JE # BR23-00028 JE Trans Date 07/01/2022 JE Posted 07/01/2022 Comment BD- ADVANCE C/O FOR CIA				
(025933) 01- 3213- 0- 0000- 0000- 8290- 830- 0000	ESSER III ARP,ALL OTHER F	DR		22,080.00
(026753) 01- 3213- 0- 1110- 1000- 5800- 530- 0000	ESSER III ARP,PROF/CONSL	CR		22,080.00
(023571) 01- 3212- 0- 0000- 0000- 8290- 830- 0000	ESSER II,ALL OTHER FEDEF	DR		50,000.00
(025412) 01- 3212- 0- 1110- 1000- 5800- 530- 0000	ESSER II,PROF/CONSULT SI	CR		50,000.00
Net increase to Appropriations			.00	144,160.00

JE # BR23-00029 JE Trans Date 07/01/2022 JE Posted 07/01/2022 Comment BD-SUMMER SCHOOL FIELDTRIPS				
(027608) 01- 3010- 0- 1110- 1000- 4399- 520- 0000	BAS GNT LOW-INC,HOLDINC	DR	1,000.00	
(032197) 01- 3010- 0- 1115- 1000- 5800- 505- 0000	BAS GNT LOW-INC,PROF/CC	CR		1,000.00
Net increase to Appropriations			1,000.00	1,000.00

JE # BR23-00030 JE Trans Date 07/05/2022 JE Posted 07/05/2022 Comment ST-ADVANCE C/O FOR CIA AVID PD SUMMER				
(032201) 01- 3213- 0- 1370- 1000- 5200- 530- 0000	ESSER III ARP,TRAVEL & CC	CR		14,000.00
(025933) 01- 3213- 0- 0000- 0000- 8290- 830- 0000	ESSER III ARP,ALL OTHER F	DR		14,000.00
Net increase to Appropriations			.00	28,000.00

Selection Grouped by Org, Fiscal Year, JE# - Sorted by JE Item #, (Org = 14, JE Type = R, Starting Post Date = 6/1/2022, Ending Post Date = 7/31/2022, Unposted JEs? = N, End Bud Bal? = O, JE# Page Break? = N, Description? = A, Recap? = N)

ESCAPE ONLINE

Page 75 of 88

Effective 04/14/2022 through 07/29/2022

Fiscal Year 2023

Account	Description	Comment	From	To
JE # BR23-00031 JE Trans Date 07/05/2022 JE Posted 07/05/2022 Comment SJ-SAVVAS LICENCES FOR ARK				
(006136) 01- 6300- 0- 1110- 1000- 4100- 530- 0000	LOTTERY:INSTRUC,APPR TI	DR	41,000.00	
(032203) 01- 6300- 0- 1110- 1000- 5800- 537- 0000	LOTTERY:INSTRUC,PROF/C	CR		41,000.00
			41,000.00	41,000.00
JE # BR23-00032 JE Trans Date 07/05/2022 JE Posted 07/05/2022 Comment AMM-BOOKS FOR LEADERSHIP				
(001101) 01- 0000- 0- 0000- 7150- 4200- 053- 0000	NO REPORTING RE,BOOKS	CR		200.00
(001066) 01- 0000- 0- 0000- 7110- 5800- 053- 0000	NO REPORTING RE,PROF/C	DR	200.00	
			200.00	200.00
JE # BR23-00033 JE Trans Date 07/05/2022 JE Posted 07/05/2022 Comment BL-PER GREG OMEARA \$2000 INTO PRINTING SVCS				
(001936) 01- 0000- 0- 1110- 1000- 4300- 035- 0000	NO REPORTING RE,MATERI	DR	2,000.00	
(001990) 01- 0000- 0- 1110- 1000- 5800- 035- 0000	NO REPORTING RE,PROF/C	CR		2,000.00
			2,000.00	2,000.00
JE # BR23-00034 JE Trans Date 07/05/2022 JE Posted 07/05/2022 Comment JL-Add More to Elem Bond Holding acct				
(010424) 21- 9734- 0- 0000- 8500- 6200- 000- 0000	BOND A ELEM,BUILDINGS &	CR		5,000,000.00
			Net increase to Appropriations	5,000,000.00
JE # BR23-00035 JE Trans Date 07/06/2022 JE Posted 07/06/2022 Comment BLAMBERT-WL FOLDERS/PALACE ORDER				
(001984) 01- 0000- 0- 1110- 1000- 5800- 027- 0000	NO REPORTING RE,PROF/C BLAMBERT-WL FOLDERS	CR		1,010.00
(001930) 01- 0000- 0- 1110- 1000- 4300- 027- 0000	NO REPORTING RE,MATERI BLAMBERT-WL FOLDERS	DR	1,010.00	
(000564) 01- 0000- 0- 0000- 2700- 4300- 027- 0000	NO REPORTING RE,MATERI BLAMBERT-PALACE	CR		700.00
(001930) 01- 0000- 0- 1110- 1000- 4300- 027- 0000	NO REPORTING RE,MATERI BLAMBERT-PALACE	DR	700.00	
			1,710.00	1,710.00
JE # BR23-00036 JE Trans Date 07/06/2022 JE Posted 07/06/2022 Comment TH-BOND REQS 9734 7/6/22				
(027692) 21- 9734- 0- 0000- 8500- 5800- 021- B004	BOND A ELEM,PROF/CONSL TH-R23-00237	CR		6,396.00
(010599) 21- 9734- 0- 0000- 8500- 6250- 020- B200	BOND A ELEM,OTHER COS1 TH-R23-00242	CR		10,000.00
(011467) 21- 9734- 0- 0000- 8500- 6202- 023- B010	BOND A ELEM,MODERNIZA1 TH-R23-00302	CR		4,140.00
(010424) 21- 9734- 0- 0000- 8500- 6200- 000- 0000	BOND A ELEM,BUILDINGS & TH-R23-00237, 00242, 00302	DR	20,536.00	
			20,536.00	20,536.00
JE # BR23-00037 JE Trans Date 07/08/2022 JE Posted 07/08/2022 Comment JL-Add Budget for Cyber Security Policy				
Selection	Grouped by Org, Fiscal Year, JE# - Sorted by JE Item #, (Org = 14, JE Type = R, Starting Post Date = 6/1/2022, Ending Post Date = 7/31/2022, Unposted JEs? = N, End Bud Bal? = O, JE# Page Break? = N, Description? = A, Recap? = N)			Page 76 of 88

Effective 04/14/2022 through 07/29/2022

Fiscal Year 2023

Account	Description	Comment	From	To
(continued) JE # BR23-00037 JE Trans Date 07/08/2022 JE Posted 07/08/2022	Comment JL-Add Budget for Cyber Security Policy			
(001463) 01-0000-0-0000-8200-5450-899-0000	NO REPORTING RE,OTHER	CR		35,000.00
Net increase to Appropriations			.00	35,000.00
JE # BR23-00038 JE Trans Date 07/08/2022 JE Posted 07/08/2022	Comment JL-For Bond Legal Fees			
(020620) 21-9733-0-0000-8500-5800-030-B199	BOND A SECONDAR,PROF/C	CR		16,000.00
(020621) 21-9734-0-0000-8500-5800-020-B199	BOND A ELEM,PROF/CONS	CR		16,000.00
(009895) 21-9733-0-0000-8500-6200-000-0000	BOND A SECONDAR,BUILDII	DR	16,000.00	
(010424) 21-9734-0-0000-8500-6200-000-0000	BOND A ELEM,BUILDINGS &	DR	16,000.00	
			32,000.00	32,000.00
JE # BR23-00039 JE Trans Date 07/08/2022 JE Posted 07/08/2022	Comment JL-For Cyber Security Policy			
(001463) 01-0000-0-0000-8200-5450-899-0000	NO REPORTING RE,OTHER	CR		1,137.00
Net increase to Appropriations			.00	1,137.00
JE # BR23-00040 JE Trans Date 07/08/2022 JE Posted 07/08/2022	Comment GO'MEARA-PRINT GALLERY PO SUMMER MAILING			
(000605) 01-0000-0-0000-2700-5800-035-0000	NO REPORTING RE,PROF/C	CR		605.00
(001936) 01-0000-0-1110-1000-4300-035-0000	NO REPORTING RE,MATERI	DR	605.00	
			605.00	605.00
JE # BR23-00041 JE Trans Date 07/08/2022 JE Posted 07/08/2022	Comment BL-DU88890 WL PTA CK4799 PARAED 8 POSITIONS			
(011163) 01-9016-0-1110-1000-4300-027-0052	DONATIONS,MATERIALS & €	CR		100,000.00
(011545) 01-9016-0-0000-0000-8699-027-0052	DONATIONS,ALL OTHER LO	DR		100,000.00
(026130) 01-9016-0-1540-1000-4300-027-0052	DONATIONS,MATERIALS & €	CR		8,040.00
	LAB EXTRA HOURS			
(011545) 01-9016-0-0000-0000-8699-027-0052	DONATIONS,ALL OTHER LO	DR		8,040.00
	LAB EXTRA HOURS			
(014587) 01-9016-0-1250-1000-4300-027-2729	DONATIONS,MATERIALS & €	CR		7,485.00
	DANCE			
(008479) 01-9016-0-0000-0000-8699-027-2729	DONATIONS,ALL OTHER LO	DR		7,485.00
	DANCE			
(014587) 01-9016-0-1250-1000-4300-027-2729	DONATIONS,MATERIALS & €	CR		6,363.00
	MUSIC			
(008479) 01-9016-0-0000-0000-8699-027-2729	DONATIONS,ALL OTHER LO	DR		6,363.00
	MUSIC			

Selection Grouped by Org, Fiscal Year, JE# - Sorted by JE Item #, (Org = 14, JE Type = R, Starting Post Date = 6/1/2022, Ending Post Date = 7/31/2022, Unposted JEs? = N, End Bud Bal? = O, JE# Page Break? = N, Description? = A, Recap? = N)

ESCAPE ONLINE

Page 77 of 88

Effective 04/14/2022 through 07/29/2022

Fiscal Year 2023

Account	Description	Comment	From	To
Net increase to Appropriations			.00	243,776.00
JE # BR23-00042 JE Trans Date 07/11/2022 JE Posted 07/11/2022 Comment TH-9734 BOND REQS				
(013762)	21-9734-0-0000-8500-6202-027-B161	BOND A ELEM,MODERNIZA1 TH-R23-00228		5,133.00
(013762)	21-9734-0-0000-8500-6202-027-B161	BOND A ELEM,MODERNIZA1 TH-R23-00246		14,082.00
(032032)	21-9734-0-0000-8500-6202-021-B006	Bond A Elem,MODERNIZATI TH-R23-00240		18,428.00
(011467)	21-9734-0-0000-8500-6202-023-B010	BOND A ELEM,MODERNIZA1 TH-R23-00247		98,428.00
(011467)	21-9734-0-0000-8500-6202-023-B010	BOND A ELEM,MODERNIZA1 TH-R23-00248		190,154.00
(011467)	21-9734-0-0000-8500-6202-023-B010	BOND A ELEM,MODERNIZA1 TH-R23-00249		104,247.00
(026985)	21-9734-0-0000-8500-4300-023-B010	BOND A ELEM,MATERIALS & TH-R23-00236		204.00
(010543)	21-9734-0-0000-8500-6210-038-B020	BOND A ELEM,ARCHITECT/E TH-R23-00423		56,343.00
(010424)	21-9734-0-0000-8500-6200-000-0000	BOND A ELEM,BUILDINGS & TH-R23-00423	571,744.00	
(010544)	21-9734-0-0000-8500-6210-038-B021	BOND A ELEM,ARCHITECT/E TH-R23-00424		84,725.00
			571,744.00	571,744.00
JE # BR23-00043 JE Trans Date 07/12/2022 JE Posted 07/12/2022 Comment SJ-LAB-AIDS LICENSE RENEWAL FOR B40M				
(006136)	01-6300-0-1110-1000-4100-530-0000	LOTTERY:INSTRUC,APPR TI	450.00	
(006169)	01-6300-0-1110-1000-5800-531-0000	LOTTERY:INSTRUC,PROF/C		450.00
			450.00	450.00
JE # BR23-00044 JE Trans Date 07/12/2022 JE Posted 07/12/2022 Comment BD- ADVANCE C/O CIA LICENSES				
(026753)	01-3213-0-1110-1000-5800-530-0000	ESSER III ARP,PROF/CONSL BD-ADVANCE C/O CIA LICENSES		48,300.00
(032215)	01-3213-0-1110-2140-5800-534-0000	ESSER III ARP,PROF/CONSL BD-ADVANCE C/O CIA LICENSES		3,000.00
(032216)	01-3213-0-1110-1000-5800-534-0000	ESSER III ARP,PROF/CONSL BD-ADVANCE C/O CIA LICENSES		22,900.00
(032218)	01-3213-0-1110-1000-5800-532-0000	ESSER III ARP,PROF/CONSL BD-ADVANCE C/O CIA LICENSES		10,373.00
(032217)	01-3213-0-1110-1000-5800-531-0000	ESSER III ARP,PROF/CONSL BD-ADVANCE C/O CIA LICENSES		21,616.00
(025933)	01-3213-0-0000-0000-8290-830-0000	ESSER III ARP,ALL OTHER F BD-ADVANCE C/O CIA LICENSES		106,189.00
(032156)	01-3213-0-1110-1000-5800-520-0000	ESSER III ARP,PROF/CONSL		8,904.00
(025932)	01-3213-0-0000-0000-8290-820-0000	ESSER III ARP,ALL OTHER F		8,904.00
Net increase to Appropriations			.00	230,186.00
JE # BR23-00045 JE Trans Date 07/12/2022 JE Posted 07/12/2022 Comment SJ-READ 180 PRINT MATERIALS FOR B40M & MHMS				
(032219)	01-3213-0-1110-1000-4200-531-0000	ESSER III ARP,BOOKS & OTI		7,267.00
(032217)	01-3213-0-1110-1000-5800-531-0000	ESSER III ARP,PROF/CONSL	7,267.00	
(032218)	01-3213-0-1110-1000-5800-532-0000	ESSER III ARP,PROF/CONSL	3,613.00	
Selection Grouped by Org, Fiscal Year, JE# - Sorted by JE Item #, (Org = 14, JE Type = R, Starting Post Date = 6/1/2022, Ending Post Date = 7/31/2022, Unposted JEs? = N, End Bud Bal? = O, JE# Page Break? = N, Description? = A, Recap? = N)				

ESCAPE ONLINE

Effective 04/14/2022 through 07/29/2022

Fiscal Year 2023

Account	Description	Comment	From	To
(continued) JE # BR23-00045 JE Trans Date 07/12/2022 JE Posted 07/12/2022	Comment SJ-READ 180 PRINT MATERIALS FOR B40M & MHMS			
(032220) 01-3213-0-1110-1000-4200-532-0000	ESSER III ARP,BOOKS & OTI		CR	3,613.00
			10,880.00	10,880.00
JE # BR23-00046 JE Trans Date 07/12/2022 JE Posted 07/12/2022	Comment JL-District Wide Project-Transportation 35% Balances			
(029721) 40-9720-0-0000-8500-5600-048-0000	2012 SERIES A G,RENTAL/LI		CR	3,119.00
(028034) 40-9720-0-0000-8500-6201-048-0000	2012 SERIES A G,NEW CON:		CR	95,550.00
(028442) 40-9720-0-0000-8500-6202-048-0000	2012 SERIES A G,MODERNIZ		CR	3,563.00
(026154) 40-9720-0-0000-8500-6210-048-0000	2012 SERIES A G,ARCHITEC		CR	48,819.00
(027926) 40-9720-0-0000-8500-6220-048-0000	2012 SERIES A G,DSA PLAN		CR	10,004.00
(026155) 40-9720-0-0000-8500-6251-048-0000	2012 SERIES A G,REIMBURSE		CR	1,578.00
(027890) 40-9720-0-0000-8500-6290-048-0000	2012 SERIES A G,INSPECT		CR	15,750.00
			Net increase to Appropriations	.00 178,383.00
JE # BR23-00047 JE Trans Date 07/12/2022 JE Posted 07/12/2022	Comment JL-Add District Set Aside Balances from 21/22			
(026911) 40-9720-0-0000-8500-6200-020-0000	2012 SERIES A G,BUILDING		CR	22,643.00
(028080) 40-9720-0-0000-8500-6202-020-0000	2012 SERIES A G,MODERNIZ		CR	7,160.00
(028082) 40-9720-0-0000-8500-6210-020-0000	2012 SERIES A G,ARCHITEC		CR	520.00
(028081) 40-9720-0-0000-8500-6220-020-0000	2012 SERIES A G,DSA PLAN		CR	2,739.00
(028083) 40-9720-0-0000-8500-6251-020-0000	2012 SERIES A G,REIMBURSE		CR	42.00
			Net increase to Appropriations	.00 33,104.00
JE # BR23-00048 JE Trans Date 07/12/2022 JE Posted 07/12/2022	Comment JL-Add District Wide for Food Service balances from 21/22			
(029631) 40-9720-0-0000-8500-6200-046-0000	2012 SERIES A G,BUILDING		CR	622,947.00
(031124) 40-9720-0-0000-8500-6210-046-0000	2012 SERIES A G,ARCHITEC		CR	19.00
(029754) 40-9720-0-0000-8500-6500-046-0000	2012 SERIES A G,EQUIPMEN		CR	13,752.00
			Net increase to Appropriations	.00 636,718.00
JE # BR23-00049 JE Trans Date 07/12/2022 JE Posted 07/12/2022	Comment JL-Add District Set Aside balances from 21/22			
(026911) 40-9720-0-0000-8500-6200-020-0000	2012 SERIES A G,BUILDING		CR	11,314.00
(028082) 40-9720-0-0000-8500-6210-020-0000	2012 SERIES A G,ARCHITEC		CR	21,462.00
(028083) 40-9720-0-0000-8500-6251-020-0000	2012 SERIES A G,REIMBURSE		CR	755.00
			Net increase to Appropriations	.00 33,531.00

Effective 04/14/2022 through 07/29/2022

Fiscal Year 2023

Account	Description	Comment	From	To
JE # BR23-00050 JE Trans Date 07/12/2022 JE Posted 07/12/2022 Comment JL-Add District Set Aside balances from 21/22				
(029632) 40- 9720- 0- 0000- 8500- 6200- 049- 0000	2012 SERIES A G,BUILDING		CR	69,120.00
(030829) 40- 9720- 0- 0000- 8500- 6202- 049- 0000	2012 SERIES A G,MODERNIZ		CR	33,768.00
Net increase to Appropriations			.00	102,888.00
JE # BR23-00051 JE Trans Date 07/12/2022 JE Posted 07/12/2022 Comment JL-Add District Set Aside Transportation balances from 21/2				
(028034) 40- 9720- 0- 0000- 8500- 6201- 048- 0000	2012 SERIES A G,NEW CON		CR	150,822.00
(027890) 40- 9720- 0- 0000- 8500- 6290- 048- 0000	2012 SERIES A G,INSCPECT		CR	2,657.00
Net increase to Appropriations			.00	153,479.00
JE # BR23-00052 JE Trans Date 07/13/2022 JE Posted 07/13/2022 Comment JL-Add District Set Aside balance from 21/22				
(030829) 40- 9720- 0- 0000- 8500- 6202- 049- 0000	2012 SERIES A G,MODERNIZ		CR	5,617.00
Net increase to Appropriations			.00	5,617.00
JE # BR23-00053 JE Trans Date 07/13/2022 JE Posted 07/13/2022 Comment JL-For ESY Mileage				
(032204) 01- 3219- 0- 5760- 1110- 5200- 205- 0000	ELO ESSERIII LL,TRAVEL &		CR	7.00
(032205) 01- 3219- 0- 5760- 1110- 5200- 250- 0000	ELO ESSERIII LL,TRAVEL &		CR	7.00
(027462) 01- 3219- 0- 1110- 1000- 4399- 820- 0000	ELO ESSERIII LL,HOLDING A		DR	7.00
(027463) 01- 3219- 0- 1110- 1000- 4399- 830- 0000	ELO ESSERIII LL,HOLDING A		DR	7.00
			14.00	14.00
JE # BR23-00054 JE Trans Date 07/14/2022 JE Posted 07/14/2022 Comment EB - Business Cards - Principal/office staff				
(001928) 01- 0000- 0- 1110- 1000- 4300- 023- 0000	NO REPORTING RE,MATERI		DR	200.00
(018440) 01- 0000- 0- 1110- 1000- 5800- 023- 0000	NO REPORTING RE,PROF/C		CR	200.00
			200.00	200.00
JE # BR23-00055 JE Trans Date 07/14/2022 JE Posted 07/14/2022 Comment EB - Business Cards - Addl				
(001928) 01- 0000- 0- 1110- 1000- 4300- 023- 0000	NO REPORTING RE,MATERI		DR	20.00
(018440) 01- 0000- 0- 1110- 1000- 5800- 023- 0000	NO REPORTING RE,PROF/C		CR	20.00
			20.00	20.00
JE # BR23-00056 JE Trans Date 07/14/2022 JE Posted 07/14/2022 Comment FL-BUS CARDS FOR PRINCIPAL/OFFICE STAFF				
(001927) 01- 0000- 0- 1110- 1000- 4300- 021- 0000	NO REPORTING RE,MATERI		DR	800.00
(000598) 01- 0000- 0- 0000- 2700- 5800- 021- 0000	NO REPORTING RE,PROF/C		CR	800.00
Selection Grouped by Org, Fiscal Year, JE# - Sorted by JE Item #, (Org = 14, JE Type = R, Starting Post Date = 6/1/2022, Ending Post Date = 7/31/2022, Unposted JEs? = N, End Bud Bal? = O, JE# Page Break? = N, Description? = A, Recap? = N)			ESCAPE ONLINE	

Effective 04/14/2022 through 07/29/2022

Fiscal Year 2023

Account	Description	Comment	From	To
			800.00	800.00
JE # BR23-00057 JE Trans Date 07/15/2022 JE Posted 07/15/2022 Comment BD-ADVANCE C/O LEXIA PD				
(032261)	01- 4127- 0- 1110- 2140- 5800- 520- 0000	ESEA:STDNT SUPP,PROF/C	CR	4,250.00
(024160)	01- 4127- 0- 0000- 0000- 8290- 520- 0000	ESEA:STDNT SUPP,ALL OTI	DR	4,250.00
Net increase to Appropriations			.00	8,500.00
JE # BR23-00058 JE Trans Date 07/15/2022 JE Posted 07/15/2022 Comment JL-ADD TK Supplie Budget				
(031367)	01- 6053- 0- 1110- 1000- 4300- 521- 0000	UNIV PRE-K PLAN,MATERIA	CR	20,000.00
(031368)	01- 6053- 0- 1110- 1000- 4300- 523- 0000	UNIV PRE-K PLAN,MATERIA	CR	20,000.00
(031369)	01- 6053- 0- 1110- 1000- 4300- 524- 0000	UNIV PRE-K PLAN,MATERIA	CR	20,000.00
(031370)	01- 6053- 0- 1110- 1000- 4300- 527- 0000	UNIV PRE-K PLAN,MATERIA	CR	20,000.00
(031371)	01- 6053- 0- 1110- 1000- 4399- 520- 0000	UNIV PRE-K PLAN,HOLDING	CR	58,555.00
(031373)	01- 6053- 0- 0000- 7210- 7310- 520- 0000	UNIV PRE-K PLAN,XFER:IND	CR	8,175.00
Net increase to Appropriations			.00	146,730.00
JE # BR23-00059 JE Trans Date 07/18/2022 JE Posted 07/18/2022 Comment BD-ELD CURRICULUM PLANNING EWRS				
(031686)	01- 4203- 0- 1195- 1000- 1130- 530- 0000	ESEA:ENGLISH LE,CERT SA	CR	720.00
(031687)	01- 4203- 0- 1195- 1000- 3101- 530- 0000	ESEA:ENGLISH LE,STRS:CE	CR	138.00
(031692)	01- 4203- 0- 1195- 1000- 3331- 530- 0000	ESEA:ENGLISH LE,MEDICAF	CR	11.00
(031694)	01- 4203- 0- 1195- 1000- 3501- 530- 0000	ESEA:ENGLISH LE,STATE U	CR	4.00
(031695)	01- 4203- 0- 1195- 1000- 3601- 530- 0000	ESEA:ENGLISH LE,WORKER	CR	14.00
(024133)	01- 4203- 0- 1110- 1000- 4399- 530- 0000	ESEA:ENGLISH LE,HOLDING	DR	887.00
Net increase to Appropriations			887.00	887.00
JE # BR23-00060 JE Trans Date 07/18/2022 JE Posted 07/18/2022 Comment JL-For Bond Audit for Measure A & B				
(020620)	21- 9733- 0- 0000- 8500- 5800- 030- B199	BOND A SECONDAR,PROF/C	CR	13,000.00
(020621)	21- 9734- 0- 0000- 8500- 5800- 020- B199	BOND A ELEM,PROF/CONSL	CR	13,000.00
(009895)	21- 9733- 0- 0000- 8500- 6200- 000- 0000	BOND A SECONDAR,BUILDII	DR	13,000.00
(010424)	21- 9734- 0- 0000- 8500- 6200- 000- 0000	BOND A ELEM,BUILDINGS &	DR	13,000.00
Net increase to Appropriations			26,000.00	26,000.00
JE # BR23-00061 JE Trans Date 07/19/2022 JE Posted 07/19/2022 Comment BD-CREDIT CARD EXPENSES				
(001207)	01- 0000- 0- 0000- 7400- 4300- 054- 0000	NO REPORTING RE,MATERI	DR	29.00

Selection Grouped by Org, Fiscal Year, JE# - Sorted by JE Item #, (Org = 14, JE Type = R, Starting Post Date = 6/1/2022, Ending Post Date = 7/31/2022, Unposted JEs? = N, End Bud Bal? = O, JE# Page Break? = N, Description? = A, Recap? = N)

ESCAPE ONLINE

Effective 04/14/2022 through 07/29/2022

Fiscal Year 2023

Account	Description	Comment	From	To
(continued) JE # BR23-00061 JE Trans Date 07/19/2022 JE Posted 07/19/2022		Comment BD-CREDIT CARD EXPENSES		
(001223) 01-0000-0-0000-7400-5800-054-0000	NO REPORTING RE,PROF/C	CR		29.00
(000164) 01-0000-0-0000-2110-4395-055-0000	NO REPORTING RE,FOOD F	CR		132.00
(000163) 01-0000-0-0000-2110-4300-055-0000	NO REPORTING RE,MATERI	DR	132.00	
			161.00	161.00
JE # BR23-00062 JE Trans Date 07/19/2022 JE Posted 07/19/2022		Comment JL-All Bay Mechanic for Rooftop AC for DO		
(007973) 01-9010-0-0000-8200-5600-899-0999	OTHER RESTRICTE,RENTAL	CR		21,045.00
		Net increase to Appropriations	.00	21,045.00
JE # BR23-00063 JE Trans Date 07/20/2022 JE Posted 07/20/2022		Comment JL-Add budget for Master Plans balance from FY 21-22		
(017406) 25-9010-0-0000-7200-5800-020-0000	OTHER RESTRICTE,PROF/C	CR		28,398.00
(017407) 25-9010-0-0000-7200-5800-030-0000	OTHER RESTRICTE,PROF/C	CR		83,217.00
		Net increase to Appropriations	.00	111,615.00
JE # BR23-00064 JE Trans Date 07/20/2022 JE Posted 07/20/2022		Comment JL-Move for Chromebooks increased costs		
(026854) 01-0000-0-1110-1000-4300-057-5729	NO REPORTING RE,MATERI	CR		24,735.00
(001315) 01-0000-0-0000-7700-5900-857-0000	NO REPORTING RE,COMMU	DR	24,735.00	
			24,735.00	24,735.00
JE # BR23-00065 JE Trans Date 07/20/2022 JE Posted 07/20/2022		Comment BL-DU89134		
(026775) 01-9010-0-5001-0000-8699-200-5640	OTHER RESTRICTE,ALL OTI BL-DU89134 STATE OF CA MEDI-CAL	DR		9,706.00
	CK30-837904 SEQ027446689			
(026777) 01-9010-0-5001-2110-4399-200-5640	OTHER RESTRICTE,HOLDIN BL-DU89134 STATE OF CA MEDI-CAL	CR		9,706.00
	CK30-837904 SEQ027446689			
(007924) 01-9010-0-0000-8110-4300-049- FACU	OTHER RESTRICTE,MATERI BL-DU89134 COAST COMMUN	CR		280.00
	PRESCH CK5041 11332340 USE			
(007599) 01-9010-0-0000-0000-8699-049- FACU	OTHER RESTRICTE,ALL OTI BL-DU89134 COAST COMMUN	DR		280.00
	PRESCH CK5041 11332340 USE			
		Net increase to Appropriations	.00	19,972.00
JE # BR23-00066 JE Trans Date 07/21/2022 JE Posted 07/21/2022		Comment JL-Add balances from FY 21/22 for Transportation Set Aside		
(026154) 40-9720-0-0000-8500-6210-048-0000	2012 SERIES A G,ARCHITEC	CR		823.00
(026155) 40-9720-0-0000-8500-6251-048-0000	2012 SERIES A G,REIMBURSE	CR		461.00
(031125) 40-9720-0-0000-8500-6280-048-0000	2012 SERIES A G,CONSTRU	CR		11,654.00
Selection	Grouped by Org, Fiscal Year, JE# - Sorted by JE Item #, (Org = 14, JE Type = R, Starting Post Date = 6/1/2022, Ending Post Date = 7/31/2022, Unposted JEs? = N, End Bud Bal? = O, JE# Page Break? = N, Description? = A, Recap? = N)			

ESCAPE ONLINE

Effective 04/14/2022 through 07/29/2022

Fiscal Year 2023

Account	Description	Comment	From	To
Net increase to Appropriations			.00	12,938.00
JE # BR23-00067 JE Trans Date 07/21/2022 JE Posted 07/21/2022 Comment JL-Add balance for District Set Aside from 21/22				
(028082)	40-9720-0-0000-8500-6210-020-0000	2012 SERIES A G,ARCHITEC	CR	6,955.00
(028083)	40-9720-0-0000-8500-6251-020-0000	2012 SERIES A G,REIMBURSE	CR	430.00
(026911)	40-9720-0-0000-8500-6200-020-0000	2012 SERIES A G,BUILDINGS	DR	5,774.00
Net increase to Appropriations			5,774.00	7,385.00
JE # BR23-00068 JE Trans Date 07/21/2022 JE Posted 07/21/2022 Comment JD - Verizon Connect Fleet Vehicle Tracking Subscrip				
(001331)	01-0000-0-0000-8110-5800-049-0000	NO REPORTING RE,PROF/C	CR	3,144.00
(001329)	01-0000-0-0000-8110-4300-049-0000	NO REPORTING RE,MATERI	DR	3,000.00
(001330)	01-0000-0-0000-8110-5600-049-0000	NO REPORTING RE,RENTAL	DR	144.00
Net increase to Appropriations			3,144.00	3,144.00
JE # BR23-00069 JE Trans Date 07/21/2022 JE Posted 07/21/2022 Comment JL-Add Advance C/O for FACU 049				
(007924)	01-9010-0-0000-8110-4300-049-0000	OTHER RESTRICTED,MATERI	CR	135,000.00
Net increase to Appropriations			.00	135,000.00
JE # BR23-00070 JE Trans Date 07/22/2022 JE Posted 07/22/2022 Comment TH-R23-00576				
(032272)	21-9734-0-0000-8500-4300-027-0000	Bond A Elem,MATERIALS & S	CR	149.00
(032278)	21-9734-0-0000-8500-4300-038-0000	Bond A Elem,MATERIALS & S	CR	298.00
(010424)	21-9734-0-0000-8500-6200-000-0000	BOND A ELEM,BUILDINGS &	DR	447.00
(032273)	21-9733-0-0000-8500-4300-032-0000	Bond A Secondar,MATERIALS	CR	149.00
(032274)	21-9733-0-0000-8500-4300-031-0000	Bond A Secondar,MATERIALS	CR	261.00
(032275)	21-9733-0-0000-8500-4300-033-0000	Bond A Secondar,MATERIALS	CR	632.00
(032276)	21-9733-0-0000-8500-4300-035-0000	Bond A Secondar,MATERIALS	CR	484.00
(032277)	21-9733-0-0000-8500-4300-034-0000	Bond A Secondar,MATERIALS	CR	632.00
(009895)	21-9733-0-0000-8500-6200-000-0000	BOND A SECONDAR,BUILDII	DR	2,158.00
Net increase to Appropriations			2,605.00	2,605.00
JE # BR23-00071 JE Trans Date 07/22/2022 JE Posted 07/22/2022 Comment JD - KNORR CHS (Co2 Feed System)				
(007924)	01-9010-0-0000-8110-4300-049-0000	OTHER RESTRICTED,MATERI	DR	33,070.00
(016897)	01-9010-0-0000-8110-6400-034-0000	OTHER RESTRICTED,EQUIPM	CR	33,070.00

Selection Grouped by Org, Fiscal Year, JE# - Sorted by JE Item #, (Org = 14, JE Type = R, Starting Post Date = 6/1/2022, Ending Post Date = 7/31/2022, Unposted JEs? = N, End Bud Bal? = O, JE# Page Break? = N, Description? = A, Recap? = N)

ESCAPE ONLINE

Page 83 of 88

Effective 04/14/2022 through 07/29/2022

Fiscal Year 2023

Account	Description	Comment	From	To
			33,070.00	33,070.00
JE # BR23-00072 JE Trans Date 07/22/2022 JE Posted 07/22/2022 Comment JD-KNORR SCHS (CO2 FEED SYSTEM)				
(007924) 01-9010-0-0000-8110-4300-049- FACU	OTHER RESTRICTE,MATERI	DR	1,736.00	
(016897) 01-9010-0-0000-8110-6400-034- FACU	OTHER RESTRICTE,EQUIPM	CR		1,736.00
			1,736.00	1,736.00
JE # BR23-00073 JE Trans Date 07/22/2022 JE Posted 07/22/2022 Comment JD-KNORR ANNUAL HEATER MAINTENANCE				
(007924) 01-9010-0-0000-8110-4300-049- FACU	OTHER RESTRICTE,MATERI	DR	13,644.00	
(032279) 01-9010-0-0000-8110-5800-033- FACU	OTHER RESTRICTE,PROF/C	CR		4,548.00
(017818) 01-9010-0-0000-8110-5800-034- FACU	OTHER RESTRICTE,PROF/C	CR		4,548.00
(032152) 01-9010-0-0000-8110-5800-035- FACU	OTHER RESTRICTE,PROF/C	CR		4,548.00
			13,644.00	13,644.00
JE # BR23-00074 JE Trans Date 07/22/2022 JE Posted 07/22/2022 Comment JD - MISCOWATER - HH EMERGENCY TANK INSTALLATI				
(007924) 01-9010-0-0000-8110-4300-049- FACU	OTHER RESTRICTE,MATERI	DR	3,300.00	
(032279) 01-9010-0-0000-8110-5800-033- FACU	OTHER RESTRICTE,PROF/C	CR		3,300.00
			3,300.00	3,300.00
JE # BR23-00075 JE Trans Date 07/22/2022 JE Posted 07/22/2022 Comment JD - CIVIC PERMITS - 22/23 ANNUAL SUBSCRIPTION (RE				
(007924) 01-9010-0-0000-8110-4300-049- FACU	OTHER RESTRICTE,MATERI	DR	4,695.00	
(007935) 01-9010-0-0000-8110-5800-049- FACU	OTHER RESTRICTE,PROF/C	CR		4,695.00
			4,695.00	4,695.00
JE # BR23-00076 JE Trans Date 07/22/2022 JE Posted 07/22/2022 Comment JD - ABACHERLI FENCE CO. - SQHS REPAIR FENCING				
(007924) 01-9010-0-0000-8110-4300-049- FACU	OTHER RESTRICTE,MATERI	DR	18,575.00	
(032152) 01-9010-0-0000-8110-5800-035- FACU	OTHER RESTRICTE,PROF/C	CR		18,575.00
			18,575.00	18,575.00
JE # BR23-00077 JE Trans Date 07/26/2022 JE Posted 07/26/2022 Comment AMM - Books for Leadership				
(001101) 01-0000-0-0000-7150-4200-053- 0000	NO REPORTING RE,BOOKS	CR		300.00
(001110) 01-0000-0-0000-7150-5800-053- 0000	NO REPORTING RE,PROF/C	DR	300.00	

Effective 04/14/2022 through 07/29/2022

Fiscal Year 2023

Account	Description	Comment	From	To
			300.00	300.00
JE # BR23-00078 JE Trans Date 07/26/2022 JE Posted 07/26/2022 Comment SJ - Activate Learning (Replacing PO22-02352)				
(006136)	01- 6300- 0- 1110- 1000- 4100- 530- 0000	LOTTERY:INSTRUC,APPR TI	DR	24,218.00
(006172)	01- 6300- 0- 1110- 1000- 5800- 535- 0000	LOTTERY:INSTRUC,PROF/C	CR	1,500.00
(027756)	01- 6300- 0- 1150- 1000- 4100- 535- 0000	LOTTERY:INSTRUC,APPR TI	CR	22,718.00
			24,218.00	24,218.00
JE # BR23-00079 JE Trans Date 07/26/2022 JE Posted 07/26/2022 Comment SJ - Vista Higher Learning for B40 (Replacing PO22-02430)				
(016820)	01- 0000- 0- 1110- 1000- 4100- 530- CMP1	NO REPORTING RE,APPR TI	DR	1,520.00
(031751)	01- 0000- 0- 1110- 1000- 4300- 531- CMP1	NO REPORTING RE,MATERI	CR	540.00
(031752)	01- 0000- 0- 1110- 1000- 5800- 531- CMP1	NO REPORTING RE,PROF/C	CR	980.00
			1,520.00	1,520.00
JE # BR23-00080 JE Trans Date 07/26/2022 JE Posted 07/26/2022 Comment JL-For Food Service Health Permits				
(009495)	13- 5310- 0- 0000- 3700- 5300- 046- 0000	CHLD NUTR:SCHOO,DUES &	CR	7,000.00
(009445)	13- 5310- 0- 0000- 0000- 8916- 046- 0000	CHLD NUTR:SCHOO,FR FUN	DR	7,000.00
(001590)	01- 0000- 0- 0000- 9300- 7616- 000- 0000	NO REPORTING RE,FR FUN	CR	7,000.00
			.00	21,000.00
Net increase to Appropriations				
JE # BR23-00081 JE Trans Date 07/26/2022 JE Posted 07/26/2022 Comment AN - Office Supplies Alphagraphics				
(001932)	01- 0000- 0- 1110- 1000- 4300- 032- 0000	NO REPORTING RE,MATERI	DR	1,500.00
(000602)	01- 0000- 0- 0000- 2700- 5800- 032- 0000	NO REPORTING RE,PROF/C	CR	1,500.00
			1,500.00	1,500.00
JE # BR23-00082 JE Trans Date 07/27/2022 JE Posted 07/27/2022 Comment AN - Accurate label				
(001932)	01- 0000- 0- 1110- 1000- 4300- 032- 0000	NO REPORTING RE,MATERI	DR	300.00
(000602)	01- 0000- 0- 0000- 2700- 5800- 032- 0000	NO REPORTING RE,PROF/C	CR	300.00
			300.00	300.00
JE # BR23-00083 JE Trans Date 07/27/2022 JE Posted 07/27/2022 Comment AN - Community printers				
(001932)	01- 0000- 0- 1110- 1000- 4300- 032- 0000	NO REPORTING RE,MATERI	DR	100.00
(020817)	01- 0000- 0- 0000- 3110- 5800- 032- 0000	NO REPORTING RE,PROF/C	CR	100.00

Selection Grouped by Org, Fiscal Year, JE# - Sorted by JE Item #, (Org = 14, JE Type = R, Starting Post Date = 6/1/2022, Ending Post Date = 7/31/2022,
Unposted JEs? = N, End Bud Bal? = O, JE# Page Break? = N, Description? = A, Recap? = N)

ESCAPE ONLINE

Effective 04/14/2022 through 07/29/2022

Fiscal Year 2023

Account	Description	Comment	From	To
			100.00	100.00
JE # BR23-00084 JE Trans Date 07/27/2022 JE Posted 07/27/2022 Comment BD-FOOD FOR PROFESSIONAL LEARNING				
(032293)	01-0000-0-0000-2110-4395-821-0000	NO REPORTING RE,FOOD F	CR	1,000.00
(032294)	01-0000-0-0000-2110-4395-823-0000	NO REPORTING RE,FOOD F	CR	1,000.00
(032295)	01-0000-0-0000-2110-4395-824-0000	NO REPORTING RE,FOOD F	CR	1,000.00
(032297)	01-0000-0-0000-2110-4395-831-0000	NO REPORTING RE,FOOD F	CR	1,000.00
(032298)	01-0000-0-0000-2110-4395-832-0000	NO REPORTING RE,FOOD F	CR	1,000.00
(032296)	01-0000-0-0000-2110-4395-838-0000	NO REPORTING RE,FOOD F	CR	1,000.00
(032299)	01-0000-0-0000-2110-4395-833-0000	NO REPORTING RE,FOOD F	CR	2,000.00
(032300)	01-0000-0-0000-2110-4395-834-0000	NO REPORTING RE,FOOD F	CR	2,000.00
(032301)	01-0000-0-0000-2110-4395-835-0000	NO REPORTING RE,FOOD F	CR	2,000.00
Net increase to Appropriations			.00	12,000.00
JE # BR23-00085 JE Trans Date 07/27/2022 JE Posted 07/27/2022 Comment BD-FOOD FOR PROFESSIONAL LEARNING				
(032305)	01-0000-0-0000-2110-4395-827-0000	NO REPORTING RE,FOOD F	CR	1,000.00
Net increase to Appropriations			.00	1,000.00
JE # BR23-00086 JE Trans Date 07/27/2022 JE Posted 07/27/2022 Comment BD-PBIS MATERIALS & SUPPLIES				
(032302)	01-0000-0-1110-1000-4300-821-PBI S	NO REPORTING RE,MATERI	CR	1,000.00
(032303)	01-0000-0-1110-1000-4300-823-PBI S	NO REPORTING RE,MATERI	CR	1,000.00
(032304)	01-0000-0-1110-1000-4300-824-PBI S	NO REPORTING RE,MATERI	CR	1,000.00
(032306)	01-0000-0-1110-1000-4300-827-PBI S	NO REPORTING RE,MATERI	CR	1,000.00
(032308)	01-0000-0-1110-1000-4300-831-PBI S	NO REPORTING RE,MATERI	CR	1,000.00
(032307)	01-0000-0-1110-1000-4300-832-PBI S	NO REPORTING RE,MATERI	CR	1,000.00
Net increase to Appropriations			.00	6,000.00
JE # BR23-00087 JE Trans Date 07/27/2022 JE Posted 07/27/2022 Comment JL-for Corsi-Rosenthal Filter Fan Boxes from Res 3212				
(023737)	01-3212-0-1110-1000-4300-820-0000	ESSER II,MATERIALS & SUP	CR	2,345.00
(029512)	01-3212-0-1110-1000-4300-830-0000	ESSER II,MATERIALS & SUP	CR	4,355.00
(023569)	01-3212-0-0000-0000-8290-820-0000	ESSER II,ALL OTHER FEDEF	DR	2,345.00
(023571)	01-3212-0-0000-0000-8290-830-0000	ESSER II,ALL OTHER FEDEF	DR	4,355.00
Net increase to Appropriations			.00	13,400.00

Selection Grouped by Org, Fiscal Year, JE# - Sorted by JE Item #, (Org = 14, JE Type = R, Starting Post Date = 6/1/2022, Ending Post Date = 7/31/2022, Unposted JEs? = N, End Bud Bal? = O, JE# Page Break? = N, Description? = A, Recap? = N)

ESCAPE ONLINE

Page 86 of 88

Effective 04/14/2022 through 07/29/2022

Fiscal Year 2023

Account	Description	Comment	From	To
JE # BR23-00088 JE Trans Date 07/27/2022 JE Posted 07/27/2022 Comment JL-For Preschool Language Scales Fifth Edition				
(006413) 01- 6500- 0- 5730- 1110- 4300- 220- 0000	SE:STATE LOCAL,MATERIAL	CR		556.00
(006670) 01- 6500- 0- 5760- 1180- 5100- 220- 0000	SE:STATE LOCAL ,SUBAGRE	DR	556.00	
			556.00	556.00
JE # BR23-00089 JE Trans Date 07/28/2022 JE Posted 07/28/2022 Comment BD-CSU CONFERENCE				
(032322) 01- 0700- 0- 0000- 3110- 5200- 035- 0000	LCFF SUPP FUNDI,TRAVEL	CR		800.00
(003648) 01- 0700- 0- 1110- 1000- 4300- 035- 0000	LCFF SUPP FUNDI,MATERIA	DR	800.00	
			800.00	800.00
JE # BR23-00090 JE Trans Date 07/28/2022 JE Posted 07/28/2022 Comment ML-PBIS TRAINING RISHI LAL				
(000993) 01- 0000- 0- 0000- 3140- 4300- 600- 0000	NO REPORTING RE,MATERI	DR	400.00	
(000995) 01- 0000- 0- 0000- 3140- 5200- 600- 0000	NO REPORTING RE,TRAVEL	CR		400.00
			400.00	400.00
JE # BR23-00091 JE Trans Date 07/29/2022 JE Posted 07/29/2022 Comment JL-Increase budget for MBG for 2022-23				
(000023) 01- 0000- 0- 0000- 0000- 8550- 020- 0050	NO REPORTING RE,MANDA	DR		646.00
(000025) 01- 0000- 0- 0000- 0000- 8550- 030- 0050	NO REPORTING RE,MANDA	DR		3,065.00
			Net increase to Appropriations	.00
				3,711.00
JE # BR23-00092 JE Trans Date 07/29/2022 JE Posted 07/29/2022 Comment JL-Increase Interest for 2022-23				
(000033) 01- 0000- 0- 0000- 0000- 8660- 020- 0000	NO REPORTING RE,INTERE	DR		29,100.00
(000034) 01- 0000- 0- 0000- 0000- 8660- 030- 0000	NO REPORTING RE,INTERE	DR		19,141.00
			Net increase to Appropriations	.00
				48,241.00
JE # BR23-00093 JE Trans Date 07/27/2022 JE Posted 07/29/2022 Comment BL-WL YMCA REFUND TO OSS, CK763732				
(008915) 01- 9016- 0- 1150- 1000- 4300- 027- 2706	DONATIONS,MATERIALS & S	CR		400.00
(008476) 01- 9016- 0- 0000- 0000- 8699- 027- 2706	DONATIONS,ALL OTHER LO	DR		400.00
			Net increase to Appropriations	.00
				800.00
JE # BR23-00094 JE Trans Date 07/29/2022 JE Posted 07/29/2022 Comment JL-Adjust SpEd Allocations per COE Estimates for 2022-23				
(004962) 01- 3310- 0- 5001- 0000- 8181- 220- 0000	SE:LOCAL ASSIST,SE:ENTIT	DR		115,247.00
(004963) 01- 3310- 0- 5001- 0000- 8181- 230- 0000	SE:LOCAL ASSIST,SE:ENTIT	CR	258,317.00	
(004964) 01- 3310- 0- 5001- 0000- 8980- 220- 0000	SE:LOCAL ASSIST,CONTRI F	CR	115,247.00	
Selection Grouped by Org, Fiscal Year, JE# - Sorted by JE Item #, (Org = 14, JE Type = R, Starting Post Date = 6/1/2022, Ending Post Date = 7/31/2022, Unposted JEs? = N, End Bud Bal? = O, JE# Page Break? = N, Description? = A, Recap? = N)				

ESCAPE ONLINE

Effective 04/14/2022 through 07/29/2022

Fiscal Year 2023

Account	Description	Comment	From	To
(continued)	JE # BR23-00094 JE Trans Date 07/29/2022 JE Posted 07/29/2022	Comment JL-Adjust SpEd Allocations per COE Estimates for 2022-23		
(004965) 01- 3310- 0- 5001- 0000- 8980- 230- 0000	SE:LOCAL ASSIST,CONTRI F	DR		258,317.00
(005331) 01- 3311- 0- 5001- 0000- 8181- 220- 0000	SE:LOCAL ASSIST,SE:ENTIT	DR		8,121.00
(005333) 01- 3311- 0- 5760- 1180- 5800- 220- 0000	SE:LOCAL ASSIST,PROF/CC	CR		8,121.00
(005332) 01- 3311- 0- 5001- 0000- 8181- 230- 0000	SE:LOCAL ASSIST,SE:ENTIT	DR		945.00
(011765) 01- 3311- 0- 5760- 1180- 5800- 230- 0000	SE:LOCAL ASSIST,PROF/CC	CR		945.00
(005350) 01- 3315- 0- 5730- 0000- 8182- 220- 0000	SE:PRESCHOOL GR,SE:DISC	DR		27,924.00
(014733) 01- 3315- 0- 5730- 3150- 5800- 220- 0000	SE:PRESCHOOL GR,PROF/C	CR		27,924.00
(006277) 01- 6500- 0- 5001- 0000- 8792- 220- 0000	SE:STATE LOCAL,APPORT >	CR	934,281.00	
(006279) 01- 6500- 0- 5001- 0000- 8980- 220- 0000	SE:STATE LOCAL,CONTRI F	DR		934,281.00
(006278) 01- 6500- 0- 5001- 0000- 8792- 230- 0000	SE:STATE LOCAL,APPORT >	DR		1,095,908.00
(006278) 01- 6500- 0- 5001- 0000- 8792- 230- 0000	SE:STATE LOCAL,APPORT >	CR	1,095,908.00	
(000055) 01- 0000- 0- 0000- 0000- 8980- 020- 0000	NO REPORTING RE,CONTRI	DR		819,034.00
(000058) 01- 0000- 0- 0000- 0000- 8980- 030- 0000	NO REPORTING RE,CONTRI	CR	837,591.00	
Net increase to Appropriations			3,241,344.00	3,296,767.00
<hr/>				
JE # BR23-00095 JE Trans Date 07/29/2022 JE Posted 07/29/2022 Comment JL-Correct Contributions				
(000055) 01- 0000- 0- 0000- 0000- 8980- 020- 0000	NO REPORTING RE,CONTRI	CR	819,034.00	
(000058) 01- 0000- 0- 0000- 0000- 8980- 030- 0000	NO REPORTING RE,CONTRI	DR		837,591.00
Net increase to Appropriations			819,034.00	837,591.00
<hr/>				
JE # BR23-00096 JE Trans Date 07/29/2022 JE Posted 07/29/2022 Comment JL-Correct Contributions				
(000055) 01- 0000- 0- 0000- 0000- 8980- 020- 0000	NO REPORTING RE,CONTRI	CR	819,034.00	
(000058) 01- 0000- 0- 0000- 0000- 8980- 030- 0000	NO REPORTING RE,CONTRI	DR		837,591.00
Net increase to Appropriations			819,034.00	837,591.00
<hr/>				
JE # BR23-00097 JE Trans Date 07/28/2022 JE Posted 07/29/2022 Comment ST-Athletic Supplies for 22/23				
(032324) 01- 0809- 0- 1400- 4200- 4300- 833- 0809	Measure T,MATERIALS & SU	CR		20,000.00
(030957) 01- 0809- 0- 1400- 4200- 4300- 834- 0809	Measure T,MATERIALS & SU	CR		20,000.00
(027205) 01- 0809- 0- 1400- 4200- 4300- 835- 0809	Measure T,MATERIALS & SU	CR		20,000.00
Net increase to Appropriations			.00	60,000.00
Total for Org 014			9,524,766.00	20,560,852.00

Org 014 Net <Decrease> in Estimated Fund Balance 8,483,760.00-

Net increase to Appropriations

Selection Grouped by Org, Fiscal Year, JE# - Sorted by JE Item #, (Org = 14, JE Type = R, Starting Post Date = 6/1/2022, Ending Post Date = 7/31/2022, Unposted JEs? = N, End Bud Bal? = O, JE# Page Break? = N, Description? = A, Recap? = N)

ESCAPE ONLINE

Page 88 of 88

SANTA CRUZ CITY SCHOOL DISTRICT

AGENDA ITEM: Disposition of Surplus Property

MEETING DATE: August 17, 2022

FROM: Jim Monreal, Assistant Superintendent, Business Services

THROUGH: Kris Munro, Superintendent

RECOMMENDATION:

Authorize the Assistant Superintendent of Business Services, or his designee, to sell or dispose of the surplus property on the attached list(s) in accordance with Board Policy 3270 and Administrative Regulation 3270A.

BACKGROUND:

Education Code Section 17545 (a) provides that the Board of Education may sell for cash any personal property belonging to the District if the property is not required for school purposes, or if it should be disposed of for the purpose of replacement, or if it is unsatisfactory or not suitable for school use. (b) The governing board may choose to conduct any sale of personal property authorized under this section by means of a public auction conducted by employees of the district or other public agencies, or by contract with a private auction firm. The board may delegate to the district employee responsible for conducting the auction the authority to transfer the personal property to the highest responsible bidder upon completion of the auction and after payment has been received by the district.

Section 17546(a) If the governing board, by a unanimous vote of those members present, finds that the property, whether one or more items, does not exceed in value the sum of two thousand five hundred dollars (\$2,500), it may be sold at private sale without advertising, by any employee of the district empowered for that purpose by the board. (b) Any item or items of property having previously been offered for sale pursuant to Section 17545, but for which no qualified bid was received, may be sold at private sale without advertising by any employee of the district empowered for that purpose by the board. (c) If the board, by a unanimous vote of those members present, finds that the property is of insufficient value to defray the costs of arranging a sale, the property may be donated to a charitable organization deemed appropriate by the board, or it may be disposed of in the local public dump on order of any employee of the district empowered for that purpose by the board.

Per Education Code 60530(b), instructional materials may be destroyed by any economical means, provided that no instructional material shall be destroyed until 30 days after the governing board has given notice to all persons who have filed a request for such notice.

AGENDA ITEM: 8.1.2.4.

FISCAL IMPACT:

None.

This work is in direct support of the following District goal and its corresponding metric:

Goal #5: SCCS will maintain a balanced budget and efficient and effective management.

SCCS BOARD OF EDUCATION
MEETING OF August 17, 2022
SURPLUS PROPERTY

DEPARTMENT: Bay View Elementary School

	# Copies	Property Description	Year/Age	Condition	Value
1.	1	26" Drums Ludwig Ensemble WFL Symphony Model	20+ years	Good condition. Will list on auction site.	\$100

It is recommended that the Board of Education authorize the Assistant Superintendent, Business Services, or his designee, to sell or dispose of the surplus property in accordance with Board Policy 3270 and Administrative Regulation 3270A.

Approval Date: _____ **Approved By:** _____

SCCS BOARD OF EDUCATION

MEETING OF August 17, 2022

SURPLUS PROPERTY

DEPARTMENT: Harbor High School Library

	# Copies	Property Description	Year/Age	Condition	Value
1.	1	Document Cameras Avervision CP135	12 years	Old, poor condition.	\$0

It is recommended that the Board of Education authorize the Assistant Superintendent, Business Services, or his designee, to sell or dispose of the surplus property in accordance with Board Policy 3270 and Administrative Regulation 3270A.

Approval Date: _____ **Approved By:** _____

SCCS BOARD OF EDUCATION

MEETING OF August 17, 2022

SURPLUS PROPERTY

DEPARTMENT: Mission Hill Middle School

	# Copies	Property Description	Year/Age	Condition	Value
1.	1	Brown Wooden Piano	old	Unusable, outside in parking lot	\$0
2.	1	Black Keyboard	old	Unusable	\$0

It is recommended that the Board of Education authorize the Assistant Superintendent, Business Services, or his designee, to sell or dispose of the surplus property in accordance with Board Policy 3270 and Administrative Regulation 3270A.

Approval Date: _____ Approved By: _____

SCCS BOARD OF EDUCATION
MEETING OF August 17, 2022
SURPLUS PROPERTY

DEPARTMENT: Gault / IT

	# Copies	Property Description	Year/Age	Condition	Value
1.	68	HP 1464	2015	End of Life	\$89

It is recommended that the Board of Education authorize the Assistant Superintendent, Business Services, or his designee, to sell or dispose of the surplus property in accordance with Board Policy 3270 and Administrative Regulation 3270A.

Approval Date: _____ **Approved By:** _____

SANTA CRUZ CITY SCHOOL DISTRICT

AGENDA ITEM: Bond Project Notices of Completion

MEETING DATE: August 17, 2022

FROM: Jim Monreal, Assistant Superintendent, Business Services

THROUGH: Kris Munro, Superintendent

RECOMMENDATION:

Accept four Bond project notices of completion.

BACKGROUND:

This work has been inspected and complies with the plans and specifications of the vendor contracts. The District has determined that these projects are complete. The Board is asked to accept completion of these projects by approving the attached Notices of Completion, which will be duly filed with the County. In order to comply with Public Contract Code, these Notices of Completion must be made official so that we can pay the contractor by required timelines and not incur financial penalties.

CONTRACTOR	PROJECT	Completion Date
Cyclone Fence & Iron	Westlake Elementary School Site Fencing and Gates	April 28, 2022
Dilbeck & Sons	District Office Automatic Door Operators	July 11, 2022
Dilbeck & Sons	DeLaveaga Elementary Kinder Window Assembly Repl.	July 15, 2022
Cal West Fence, Inc.	Soquel High School Security Fencing	July 15, 2022

FISCAL IMPACT:

None.

This work is in direct support of the following District goals and their corresponding metrics:

- Goal #2: SCCS will create positive, engaging school environments that promote the development of cognitive skills and the social emotional well-being of all students.
- Goal #5: SCCS will maintain a balanced budget and efficient and effective management.
- Goal #6: SCCS will maintain strong communication and partnership with its diverse community.

Prepared by Trevor Miller, Director, Facility Services



Santa Cruz City Schools
Facility Services
536 Palm Street, Santa Cruz, CA 95060
(831) 429-3904

NOTICE OF COMPLETION

Date: August 17, 2022
To: Dilbeck & Sons, Inc.
Project: District Office Automatic Door Operators,
Santa Cruz City Schools

THE SANTA CRUZ CITY SCHOOLS DISTRICT HEREBY GIVES NOTICE THAT:

The address of this School District is 133 Mission Street, Suite 100, Santa Cruz, California 95060.

On January 12, 2022, this District contracted with: Dilbeck & Sons, Inc. 26 Quail Run Circle, Salinas CA 95037 as Contractor; and with Fidelity and Deposit Company of Maryland as Surety for said Contractor, for work District Office Automatic Door Operators performed on District grounds at: District Office, 133 Mission Street, Santa Cruz, Ca 95065.

It has been certified that this work has been inspected and complies with the plans and specifications, and that the Contractor completed the work on July 11, 2022.

The work of improvement described above is accepted as completed, and the Assistant Superintendent for Business Services has filed for recording this Notice as a Notice of Completion in connection with that contract.

Jim Monreal
Assistant Superintendent, Business Services
Santa Cruz City Schools



Santa Cruz City Schools
Facility Services
536 Palm Street, Santa Cruz, CA 95060
(831) 429-3904

NOTICE OF COMPLETION

Date: August 18, 2022
To: Cal West Fence, Inc.
Project: Soquel High School New Security Fencing,
Santa Cruz City Schools

THE SANTA CRUZ CITY SCHOOLS DISTRICT HEREBY GIVES NOTICE THAT:

The address of this School District is 133 Mission Street, Suite 100, Santa Cruz, California 95060.

On March 24, 2022, this District contracted with: Cal West fence, Inc., 12505 Sycamore Ave, San Martin CA 95046 as Contractor; and with Old Republic Surety Company as Surety for said Contractor, for work of New security fencing performed on District grounds at: Soquel High School 401 Soquel San Jose Rd., Soquel CA 90573.

It has been certified that this work has been inspected and complies with the plans and specifications, and that the Contractor completed the work on July 15, 2022.

The work of improvement described above is accepted as completed, and the Assistant Superintendent for Business Services has filed for recording this Notice as a Notice of Completion in connection with that contract.

Jim Monreal
Assistant Superintendent, Business Services
Santa Cruz City Schools



Santa Cruz City Schools
Facility Services
536 Palm Street, Santa Cruz, CA 95060
(831) 429-3904

NOTICE OF COMPLETION

Date: August 17, 2022
To: Cyclone Fence & Iron, Inc.
Project: Westlake Elementary School Fencing and Gates,
Santa Cruz City Schools

THE SANTA CRUZ CITY SCHOOLS DISTRICT HEREBY GIVES NOTICE THAT:

The address of this School District is 133 Mission Street, Suite 100, Santa Cruz, California 95060.

On June 22, 2020, this District contracted with: Cyclone Fence & Iron, Inc. P.O. Box 1418 San Martin, CA 95046 as Contractor; and with Liberty Mutual Surety as Surety for said Contractor, for work of Fencing and Gates performed on District grounds at: Westlake Elementary School 1000 High Street, Santa Cruz, CA 95060.

It has been certified that this work has been inspected and complies with the plans and specifications, and that the Contractor completed the work on April 28, 2022 .

The work of improvement described above is accepted as completed, and the Assistant Superintendent for Business Services has filed for recording this Notice as a Notice of Completion in connection with that contract.

Jim Monreal
Assistant Superintendent, Business Services
Santa Cruz City Schools



Santa Cruz City Schools
Facility Services
536 Palm Street, Santa Cruz, CA 95060
(831) 429-3904

NOTICE OF COMPLETION

Date: August 17, 2022
To: Dilbeck & Sons, Inc.
Project: DeLaveaga Elementary School Kindergarten Window Assembly Replacement,
Santa Cruz City Schools

THE SANTA CRUZ CITY SCHOOLS DISTRICT HEREBY GIVES NOTICE THAT:

The address of this School District is 133 Mission Street, Suite 100, Santa Cruz, California 95060.

On January 12, 2022, this District contracted with: Dilbeck & Sons, Inc. 26 Quail Run Circle, Salinas CA 95037 as Contractor; and with Fidelity & Deposit Company of Maryland as Surety for said Contractor, for work of Kindergarten Window Assembly Replacement performed on District grounds at: DeLaveaga Elementary School, 1145 Morrissey Blvd, Santa Cruz, Ca 95065.

It has been certified that this work has been inspected and complies with the plans and specifications, and that the Contractor completed the work on July 15, 2022. .

The work of improvement described above is accepted as completed, and the Assistant Superintendent for Business Services has filed for recording this Notice as a Notice of Completion in connection with that contract.

Jim Monreal
Assistant Superintendent, Business Services
Santa Cruz City Schools

SANTA CRUZ CITY SCHOOL DISTRICT

AGENDA ITEM: Site Master Plan Updates Proposals

MEETING DATE: August 17, 2022

FROM: Jim Monreal, Assistant Superintendent, Business Services

THROUGH: Kris Munro, Superintendent

RECOMMENDATION:

Ratify architect proposals for site master plan updates.

BACKGROUND:

This proposal consists of the development of an updated facility master plan at the site level to highlight the work recently completed under Measures A & B and to identify the needs that still need to be completed based on district, community and site input. This work provides all site maps and related information to support the updated Facilities Master Plan.

FISCAL IMPACT:

\$160,000.00 Developer Fees (Restricted)

This work is in direct support of the following District goals and their corresponding metrics:

- Goal #2: SCCS will create positive, engaging school environments that promote the development of cognitive skills and the social emotional well-being of all students.
- Goal #5: SCCS will maintain a balanced budget and efficient and effective management.
- Goal #6: SCCS will maintain strong communication and partnership with its diverse community.

Prepared by Trevor Miller, Director, Facility Services

April 20, 2022

Trevor Miller
Director of Facility Services
Santa Cruz City Schools
536 Palm Street
Santa Cruz, CA 95060

RE: Santa Cruz City Schools
Facilities Master Plan update information
19six #22139.01

Dear Mr. Miller:

Thank you for the opportunity to provide you with professional services. 19six Architects (19six) are pleased to submit this proposal to gather and collate information to provide the District's Master Planning company the resources to expedite a Facilities Master Plan update in support of a possible Local Obligation Bond measure.

PROJECT DESCRIPTION

Santa Cruz City Schools would like to update the original Master Plan developed in 2016. 19six will gather and collate all relevant material listed under the scope of services and provide editable site plans and relevant record documents to the District's Master Planning company per their request.

SCHEDULE

The following are preliminary timelines.

TIMELINE

FMP Information gathering and collation.....SIX WEEKS

SCOPE OF SERVICES AND FEES

The following identifies the information that will be provided for each school site to develop the update to the SCCS FMP.

1. Original (pre-bond) campus site plan prior to any new projects being done. (site plan used in 2016 FMP)
2. Current campus site plan that shows and notes recent projects completed.
3. Future Campus site plan showing future scope of projects which includes identified upcoming projects, projects identified on original FMP but not completed and other projects identified through the FMP update.
4. Provide photos of original (pre-bond) campus.
5. Provide photos taken of completed bond projects and other district upgrades done since bond, including any drone photos that have been done.

6. Provide any project renderings and site plan renderings done for completed projects or projects upcoming. Provide only those that have been completed to date.
7. Scope of bond completed projects and associated construction costs (and soft costs if available).
8. Scope of any upcoming (in design or planning as part of bond program) projects and their estimated costs

Notes:

- a. Costs will be rounded appropriately to be consistent with 2016 FMP
- b. The site plans will be based on a Google Earth image to match the site plans used in the 2016 SCCS FMP for consistency.

A breakdown of the services is as follows:

A. BAY VIEW ELEMENTARY FMP update information	\$ 10,000
B. BRANCIORTE SMALL SCHOOLS FMP update information	\$ 10,000
C. DELAVEAGA ELEMENTARY SCHOOL FMP update information	\$ 10,000
D. NATURAL BRIDGE PROFESSIONAL FEES FMP update information	\$ 10,000
E. SOQUEL HIGH SCHOOL FMP update information	<u>\$ 15,000</u>
Total Fixed Fee	\$ 55,000

REIMBURSABLE EXPENSES - There are no reimbursable expenses anticipated for this project. If any reimbursable expenses do arise, 19six shall notify the Owner and get authorization prior to incurring said expense. Reimbursable expenses will be billed at a rate of 1.15 times.

EXCLUSIONS - The following are not included in our services described above:

- All fees related to testing, surveys, and agency fees
- No Master planning, Architecture or Engineering services are required

We will bill you monthly based on a percentage complete basis. Payment is expected within 30 days of the billing date.

Services will be managed by 19six Principal Ralph le Roux. The project will be executed under the direction of Alan Kroeker, Architect - license number C-22474.

If this proposal meets with your approval, please either sign below, or have your legal counsel prepare a contract. If time is of the essence, we will start work upon your written authorization.

Thank you for this opportunity to be of service.

Sincerely,



Ralph le Roux
Principal
19six Architects



Alan Kroeker, Architect
President
19six Architects

Approved:



(Signature)

(Name, Title)

06/15/22

(Date)

**Exhibit A
Amendment to Master Agreement
Gault Elementary School
Facilities Master Plan Update Assistance**

Pursuant to the agreement between Santa Cruz City Schools ("District") and Bartos Architecture, Inc. ("Architect") effective 14 December 2016 ("Agreement") for the Santa Cruz City Schools Measure A and B construction program, the District and Architect agree to amend the Agreement to add the following scope of assistance to the services provided: *Facilities Master Plan Update Assistance for Gault Elementary School*

- The terms of the Agreement are incorporated into, and govern, this amendment except as may be provided otherwise by this amendment. In the event of conflict between the Agreement and this amendment, the terms of amendment control.
- For the project, Architect shall provide hourly on-call supplemental assistance to district staff in coordination with District's Facilities Master Plan Update Architect. Anticipated services anticipated include updates to existing master plan diagrams, updates to expected ROM budgetary costs, miscellaneous meetings, and other requested services.
- For the services performed under this amendment to the Agreement, the Architect shall be compensated monthly according to his hourly rate schedule (Exhibit C to the Agreement). Architect's total compensation shall not exceed \$10,000.
- Reimbursable expenses for Printing, Scanning, Expedited Delivery, and Agency fees *shall not be marked up* and are excluded from fee. Architect *shall not invoice* for travel time or Mileage expense to and from job sites.
- Architect shall assign qualified staff as deemed necessary by Architect as necessitated by project.
- Architect shall have errors and omissions insurance on a claims-made basis: Two Million Dollars (\$2,000,000) per claim with a Two Million Dollar (\$2,000,000) aggregate, with a \$10,000 deductible for a period of three years beyond project completion.

Architect Bartos Architecture, Inc.

District Santa Cruz City Schools

By: Mark Bartos, Architect-President, C24138

By: Jimmy Monreal, Assistant Superintendent

5/26/22
Date

07/05/22
Date

Exhibit A.1
Amendment to Master Agreement
Westlake Elementary School

Facilities Master Plan Update Assistance

Pursuant to the agreement between Santa Cruz City Schools ("District") and Bartos Architecture, Inc. ("Architect") effective 14 December 2016 ("Agreement") for the Santa Cruz City Schools Measure A and B construction program, the District and Architect agree to amend the Agreement to add the following scope of assistance to the services provided: *Facilities Master Plan Update Assistance for Westlake Elementary School*

- The terms of the Agreement are incorporated into, and govern, this amendment except as may be provided otherwise by this amendment. In the event of conflict between the Agreement and this amendment, the terms of amendment control.
- For the project, Architect shall provide hourly on-call supplemental assistance to district staff in coordination with District's Facilities Master Plan Update Architect. Anticipated services anticipated include updates to existing master plan diagrams, updates to expected ROM budgetary costs, miscellaneous meetings, and other requested services.
- For the services performed under this amendment to the Agreement, the Architect shall be compensated monthly according to his hourly rate schedule (Exhibit C to the Agreement). Architect's total compensation shall not exceed \$10,000.
- Reimbursable expenses for Printing, Scanning, Expedited Delivery, and Agency fees *shall not be marked up* and are excluded from fee. Architect *shall not invoice* for travel time or Mileage expense to and from job sites.
- Architect shall assign qualified staff as deemed necessary by Architect as necessitated by project.
- Architect shall have errors and omissions insurance on a claims-made basis: Two Million Dollars (\$2,000,000) per claim with a Two Million Dollar (\$2,000,000) aggregate, with a \$10,000 deductible for a period of three years beyond project completion.

Architect Bartos Architecture, Inc.



By: Mark Bartos, Architect-President, C24138

5/26/22

Date

District Santa Cruz City Schools

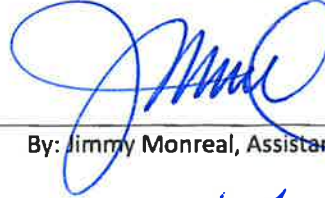

By: Jimmy Monreal, Assistant Superintendent

07/08/22

Date

Exhibit A
Amendment to Master Agreement
Mission Hill Middle School

Facilities Master Plan Update Assistance

Pursuant to the agreement between Santa Cruz City Schools ("District") and Bartos Architecture, Inc. ("Architect") effective 14 December 2016 ("Agreement") for the Santa Cruz City Schools Measure A and B construction program, the District and Architect agree to amend the Agreement to add the following scope of assistance to the services provided: *Facilities Master Plan Update Assistance for Mission Hill Middle School*

- The terms of the Agreement are incorporated into, and govern, this amendment except as may be provided otherwise by this amendment. In the event of conflict between the Agreement and this amendment, the terms of amendment control.
- For the project, Architect shall provide hourly on-call supplemental assistance to district staff in coordination with District's Facilities Master Plan Update Architect. Anticipated services anticipated include updates to existing master plan diagrams, updates to expected ROM budgetary costs, miscellaneous meetings, and other requested services.
- For the services performed under this amendment to the Agreement, the Architect shall be compensated monthly according to his hourly rate schedule (Exhibit C to the Agreement). Architect's total compensation shall not exceed \$15,000.
- Reimbursable expenses for Printing, Scanning, Expedited Delivery, and Agency fees *shall not be marked up* and are excluded from fee. Architect *shall not invoice* for travel time or Mileage expense to and from job sites.
- Architect shall assign qualified staff as deemed necessary by Architect as necessitated by project.
- Architect shall have errors and omissions insurance on a claims-made basis: Two Million Dollars (\$2,000,000) per claim with a Two Million Dollar (\$2,000,000) aggregate, with a \$10,000 deductible for a period of three years beyond project completion.

Architect Bartos Architecture, Inc.



By: Mark Bartos, Architect-President, C24138

5/26/22

Date

District Santa Cruz City Schools

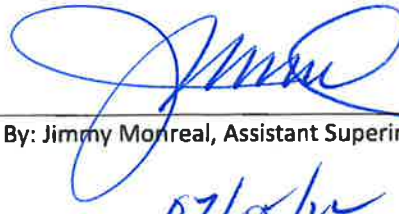

By: Jimmy Monreal, Assistant Superintendent

07/08/22

Date

Exhibit A
Amendment to Master Agreement
Santa Cruz High School

Facilities Master Plan Update Assistance

Pursuant to the agreement between Santa Cruz City Schools ("District") and Bartos Architecture, Inc. ("Architect") effective 14 December 2016 ("Agreement") for the Santa Cruz City Schools Measure A and B construction program, the District and Architect agree to amend the Agreement to add the following scope of assistance to the services provided: *Facilities Master Plan Update Assistance for Santa Cruz High School*

- The terms of the Agreement are incorporated into, and govern, this amendment except as may be provided otherwise by this amendment. In the event of conflict between the Agreement and this amendment, the terms of amendment control.
- For the project, Architect shall provide hourly on-call supplemental assistance to district staff in coordination with District's Facilities Master Plan Update Architect. Anticipated services anticipated include updates to existing master plan diagrams, updates to expected ROM budgetary costs, miscellaneous meetings, and other requested services.
- For the services performed under this amendment to the Agreement, the Architect shall be compensated monthly according to his hourly rate schedule (Exhibit C to the Agreement). Architect's total compensation shall not exceed \$15,000.
- Reimbursable expenses for Printing, Scanning, Expedited Delivery, and Agency fees *shall not be marked up* and are excluded from fee. Architect *shall not invoice* for travel time or Mileage expense to and from job sites.
- Architect shall assign qualified staff as deemed necessary by Architect as necessitated by project.
- Architect shall have errors and omissions insurance on a claims-made basis: Two Million Dollars (\$2,000,000) per claim with a Two Million Dollar (\$2,000,000) aggregate, with a \$10,000 deductible for a period of three years beyond project completion.

Architect Bartos Architecture, Inc.



By: Mark Bartos, Architect-President, C24138

5/26/22

Date

District Santa Cruz City Schools

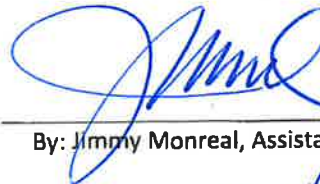

By: Jimmy Monreal, Assistant Superintendent

07/10/22

Date

Belli Project #22020

**FORM OF AMENDMENT TO ADD PROJECT TO AGREEMENT
(Percentage Fee)**

Pursuant to the agreement between the Santa Cruz City Schools (“District”) and Belli Architectural Group, Inc. (“Architect”) effective January 17, 2017 (“Agreement”) for the Measure A construction program, the District and Architect agree to amend the Agreement to add architectural services for design and construction administration of the following Branciforte Middle School project (“Project”):

Master Plan Update

The following identifies the information required develop the update to the SCCS FMP.

1. Original (pre-bond) campus site plan prior to any new projects being done.
2. Current campus site plan that shows and notes recent projects completed.
3. Future Campus site plan showing future scope of projects which includes identified upcoming projects, projects identified on original FMP but not completed and other projects identified through the FMP update.
4. Provide photos of original (pre-bond) campus.
5. Provide photos taken of completed bond projects and other district upgrades done since bond, including any drone photos that have been done.
6. Provide any project renderings and site plan renderings done for completed projects or projects upcoming.
7. Scope of bond completed projects and associated construction costs and soft costs if available.
8. Scope of any upcoming (in design or planning as part of bond program) projects and their estimated costs.

The terms of the Agreement are incorporated into, and govern, this amendment except as may be provided otherwise by this amendment. In the event of a conflict between the Agreement and this amendment, the terms of this amendment shall control.

For the Projects, Architect shall perform the Basic and Additional Services specified in the Agreement and this amendment. Design-Bid-Build construction contracts are being used as the delivery method for the Project.

For the Basic Services satisfactorily performed under this amendment to the Agreement, the total compensation paid to the Architect for the Project shall be a fixed fee of \$15,000 billed on a percent complete basis.

Upon any adjustment (increase or decrease) to the Project Construction Cost as contemplated by section 1.9 of the Agreement, including but not limited to any adjustment made at such time as bids are received, the Architect’s total compensation for Basic Services for the Project shall also be increased or decreased, including retroactively for Basic Services already performed and payments already made. Such adjustments may be effected by the District by either (a) adjusting any

{SR208531}

future payment due under the payment schedule immediately above, or (b) issuing a revision notice to Architect that either tenders any additional payment owed or demands reimbursement from the Architect of any overpayment to date.

Architect's total reimbursement for Reimbursable Expenses shall not exceed \$15,000, which is Architect's estimate of the maximum total cost of Reimbursable Expenses on the Project prior to completion of Project Development Studies Phase. Expense shall be subject to adjustment after completion of aforementioned phase.

Architect shall provide a minimum of two (2) full-time employees for the Project.

For the period of this Project, the Architect shall have errors and omissions insurance on an occurrence basis, with limits of at least One Million Dollars (\$1,000,000) and with a deductible in an amount not to exceed the sum of Thirty Thousand Dollars (\$30,000).

ARCHITECT:

Belli Architectural Group, Inc.

By: David Peartree
David N. Peartree, President

Digitally signed by David Peartree
DN: C=US, E=david@belliag.com,
O=Belli Architectural Group,
OU=Belli Architectural Group,
CN=David Peartree
Date: 2022.05.25 06:33:50-07'00'

DISTRICT:

SANTA CRUZ CITY SCHOOLS

By: [Signature] 05/10/22
Assistant Superintendent, Business
Services

Belli Project #22021

**FORM OF AMENDMENT TO ADD PROJECT TO AGREEMENT
(Percentage Fee)**

Pursuant to the agreement between the Santa Cruz City Schools (“District”) and Belli Architectural Group, Inc. (“Architect”) effective January 17, 2017 (“Agreement”) for the Measure A construction program, the District and Architect agree to amend the Agreement to add architectural services for design and construction administration of the following Harbor High School project (“Project”):

Master Plan Update

The following identifies the information required develop the update to the SCCS FMP.

1. Original (pre-bond) campus site plan prior to any new projects being done.
2. Current campus site plan that shows and notes recent projects completed.
3. Future Campus site plan showing future scope of projects which includes identified upcoming projects, projects identified on original FMP but not completed and other projects identified through the FMP update.
4. Provide photos of original (pre-bond) campus.
5. Provide photos taken of completed bond projects and other district upgrades done since bond, including any drone photos that have been done.
6. Provide any project renderings and site plan renderings done for completed projects or projects upcoming.
7. Scope of bond completed projects and associated construction costs and soft costs if available.
8. Scope of any upcoming (in design or planning as part of bond program) projects and their estimated costs.

The terms of the Agreement are incorporated into, and govern, this amendment except as may be provided otherwise by this amendment. In the event of a conflict between the Agreement and this amendment, the terms of this amendment shall control.

For the Projects, Architect shall perform the Basic and Additional Services specified in the Agreement and this amendment. Design-Bid-Build construction contracts are being used as the delivery method for the Project.

For the Basic Services satisfactorily performed under this amendment to the Agreement, the total compensation paid to the Architect for the Project shall be a fixed fee of \$15,000 billed on a percent complete basis.

Upon any adjustment (increase or decrease) to the Project Construction Cost as contemplated by section 1.9 of the Agreement, including but not limited to any adjustment made at such time as bids are received, the Architect’s total compensation for Basic Services for the Project shall also be increased or decreased, including retroactively for Basic Services already performed and payments already made. Such adjustments may be effected by the District by either (a) adjusting any

{SR208531}

future payment due under the payment schedule immediately above, or (b) issuing a revision notice to Architect that either tenders any additional payment owed or demands reimbursement from the Architect of any overpayment to date.

Architect's total reimbursement for Reimbursable Expenses shall not exceed \$15,000, which is Architect's estimate of the maximum total cost of Reimbursable Expenses on the Project prior to completion of Project Development Studies Phase. Expense shall be subject to adjustment after completion of aforementioned phase.

Architect shall provide a minimum of two (2) full-time employees for the Project.

For the period of this Project, the Architect shall have errors and omissions insurance on an occurrence basis, with limits of at least One Million Dollars (\$1,000,000) and with a deductible in an amount not to exceed the sum of Thirty Thousand Dollars (\$30,000).

ARCHITECT:

Belli Architectural Group, Inc.

Digitally signed by David Peartree
DN: C=US, E=david@belliag.com,
O=Belli Architectural Group,
OU=Belli Architectural Group,
CN=David Peartree
Date: 2022.05.25 06:35:01-07'00'

By: David Peartree
David N. Peartree, President

DISTRICT:

SANTA CRUZ CITY SCHOOLS

By:  06/15/22
Assistant Superintendent, Business
Services

SANTA CRUZ CITY SCHOOL DISTRICT

AGENDA ITEM: Certificated Personnel Actions

MEETING DATE: August 17, 2022

FROM: Molly Parks, Assistant Superintendent of Human Resources

THROUGH: Kris Munro, Superintendent

RECOMMENDATION:

Approve the certificated personnel actions as submitted.

BACKGROUND:

The attached certificated personnel actions are submitted in accordance with District policy, California Education Code and the negotiated contract.

This work is in direct support of the following District goals and their corresponding metrics:

Goal #1: All SCCS students will be prepared to successfully access post-secondary college and career opportunities.

Goal #2: SCCS will create positive, engaging school environments that promote the development of cognitive skills and the social emotional well-being of all students.

Goal #3: We will eliminate the achievement gaps that currently exist between demographic groups within the SCCS student community.

Goal #4: We will develop a highly collaborative, professional culture focused on supporting effective teaching.

2022-2023 CERTIFICATED APPOINTMENTS:

Sarah Cooper, 1.0 Resource Specialist at Branciforte Middle. Sarah's educational background includes a BA in Cal Poly San Luis Obispo. She holds a Clear Education Specialist Instruction Credential for Mild to Moderate Disabilities and an English Learners Authorization. Sarah has five years of teaching experience and her status is Probationary 1.

Gloriana Garcia, 1.0 Special Day Class Teacher at Soquel High. Gloria's educational background includes a BA in Journalism from San Francisco State University and an MA in Education from Santa Clara University. She holds a Clear Education Specialist Instruction Credential for Mild to Moderate Disabilities and an English Learners Authorization. Gloriana has eleven years of teaching experience and her status is Probationary 1.

Tascha Foy, .40 Speech Therapist. Tascha's educational background includes a BA in Media Communications from Florida State University and an MA in Communication Sciences and Disorders from the University of Texas at Dallas. She holds a Clear Clinical Rehabilitative Services Credential for Language, Speech & Hearing. Tascha has fifteen years of experience and her status is Temporary.

Daniel Lopez-Adame, .20 Math Teacher at Mission Hill and the ARK. Daniel's educational background includes a BA in Mathematics and an MA in Education from UC Santa Cruz. He holds a Clear Single Subject Teaching Credential for Mathematics and an English Learners Authorization. Daniel completed his student teaching at Pajaro Valley High School and his status is Probationary 1.

Kelly Lynch, .80 School Nurse. Kelly's educational background includes an AA in Nursing from Cabrillo College and a BA in Tourism from the University of Hawaii. She holds a Preliminary School Nurse Services Credential. Kelly has ten years of nursing experience and her status is Probationary 1.

Lauren Markle, 1.0 Resource Specialist at Westlake Elementary. Lauren's educational background includes a BA in Child Development from CSU Chico and an MA in Education from UC Santa Cruz. She holds a Preliminary Multiple Subject Teaching Credential, English Learners Authorization and a Short Term Staff Permit for Mild to Moderate Disabilities. Lauren completed her student teaching at Westlake Elementary and her status is Probationary 1.

Catherine Sierra, .40 4th/5th Grade Teacher at DeLaveaga Elementary. Catherine's educational background includes a BA in Elementary Education from the University of Dallas. She holds a Clear Multiple Subject Teaching Credential and an English Learners Authorization. Catherine has six years of teaching experience and her status is Temporary.

2021-2022 EXTRA WORK ASSIGNMENTS:

Noelle Alaimo, Biology Collaboration Time, Soquel High, 5/16/22 –6/30/22, not to exceed 6 hours

Leah Browne, Summer School Credit Recovery Teacher, Curriculum, Intervention & Assessment, 5/16/22 –6/30/22, not to exceed 158 hours

Leah Browne, Summer School Credit Recovery Teacher, Curriculum, Intervention & Assessment, 7/1/22 –7/15/22, not to exceed 30 hours

Chrisa Burr, TK Professional Development, Curriculum, Intervention & Assessment, 7/16/22 –8/9/22, not to exceed 3 hours

Kristen Cameron, Elementary ELD Professional Development Planning, Curriculum, Intervention & Assessment, 5/16/22 –6/15/22, not to exceed 10 hours

Kristen Cameron, ELD Summer Coaching Planning, Curriculum, Intervention & Assessment, 7/1/22 –8/15/22, not to exceed 10 hours

Kali Campbell, Curriculum & Assessment Math Cohort, Curriculum, Intervention & Assessment, 5/16/22 –6/15/22, not to exceed 21 hours

Anne Cappiello, New Teacher Mentor, Harbor High, 7/16/22 –12/15/22, not to exceed 2 hours

Alyssa Cardenas, Elementary Summer School Teacher, Curriculum, Intervention & Assessment, 7/1/22 –6/15/22, not to exceed 50 hours

Kendra Carmichael, Bright Solutions for Dyslexia Training, Special Education, 7/15/22 –8/9/22, not to exceed 12 hours

Joseph Castillo, Elementary Summer School Teacher, Curriculum, Intervention & Assessment, 7/1/22 –6/15/22, not to exceed 50 hours

Andrew Castro, Summer School Substitute Teacher, Curriculum, Intervention & Assessment, 6/21/22 –6/30/22, not to exceed 3 hours

Amanda Chausse, Elementary Summer School Teacher, Curriculum, Intervention & Assessment, 7/1/22 –6/15/22, not to exceed 50 hours

2021-2022 EXTRA WORK ASSIGNMENTS (continued):

Lolomi Dockham, Elementary Summer School Teacher, Curriculum, Intervention & Assessment, 7/1/22 –6/15/22, not to exceed 50 hours

Shelby Dong, Elementary Summer School Teacher, Curriculum, Intervention & Assessment, 7/1/22 – 6/15/22, not to exceed 50 hours

Thomas French, New Teacher Mentor, Harbor High, 7/16/22 –12/15/22, not to exceed 2 hours

James Gaynor, Title IX Training, Harbor High, 5/16/22 –6/30/22, not to exceed 8 hours

Payam Gregory Etemadzadeh, History Civic Project Leadership Workshop, Curriculum, Intervention & Assessment, 7/1/22 –7/15/22, not to exceed 8 hours

Virginia Hartman, Home and Hospital Instruction, Student Services, 8/10/22 –5/25/23, not to exceed 200 hours

Krista Holt, TK Professional Development, Curriculum, Intervention & Assessment, 7/16/22 –8/9/22, not to exceed 3 hours

Morgan Horn, Elementary Summer School Teacher, Curriculum, Intervention & Assessment, 7/1/22 – 6/15/22, not to exceed 50 hours

Jessica Humburg, Biology Collaboration Time, Soquel High, 5/16/22 –6/30/22, not to exceed 6 hours

Jordan Kreyche, Summer School Substitute Teacher, Special Education, 7/1/22 –7/15/22, not to exceed 5 hours

Jamin Laney, Summer School Credit Recovery Teacher, Curriculum, Intervention & Assessment, 5/16/22 –6/30/22, not to exceed 162 hours

Jamin Laney, Summer School Credit Recovery Teacher, Curriculum, Intervention & Assessment, 7/1/22 –7/15/22, not to exceed 27 hours

Anastacie Lenoir, Summer School Substitute Teacher, Curriculum, Intervention & Assessment, 7/1/22 –7/15/22, not to exceed 5 hours

2021-2022 EXTRA WORK ASSIGNMENTS (continued):

Spencer Marshak, Link Crew Advisor, Soquel High, 7/1/22 –8/9/22, not to exceed 40 hours

Kasha Maslowski, Biology Collaboration Time, Soquel High, 5/16/22 –6/30/22, not to exceed 6 hours

Steve McDowell, RTI Consulting, Curriculum, Intervention & Assessment, 7/1/22 –6/30/23, not to exceed 30 hours

Steve McDowell, Math Department Mentoring, Soquel High, 8/16/22 –12/15/23, not to exceed 20 hours

Melinda Moxley, Summer School Substitute Teacher, Curriculum, Intervention & Assessment, 6/1/22 –6/30/22, not to exceed 10 hours

Jacqueline Olin, Elementary Summer School Teacher, Curriculum, Intervention & Assessment, 7/1/22 –6/15/22, not to exceed 50 hours

Laura Pendergraft, New Teacher Mentor, Harbor High, 7/16/22 –12/15/22, not to exceed 2 hours

Julianna Perry, Designated ELD Summer Curriculum Planning, Curriculum, Intervention & Assessment, 7/1/22 –8/15/22, not to exceed 10 hours

Jaina Ponkey, Elementary Summer School Teacher, Curriculum, Intervention & Assessment, 7/1/22 –6/15/22, not to exceed 50 hours

Carmia Powell, New Teacher Mentor, Harbor High, 7/16/22 –12/15/22, not to exceed 2 hours

Ayla Reed, Elementary Summer School Teacher, Curriculum, Intervention & Assessment, 7/1/22 –6/15/22, not to exceed 50 hours

Esteban Reyes, Elementary Summer School Teacher, Curriculum, Intervention & Assessment, 7/1/22 –6/15/22, not to exceed 50 hours

Ricardo Reyes, Summer School Substitute Teacher, Curriculum, Intervention & Assessment, 6/16/22 –6/30/22, not to exceed 5 hours

2021-2022 EXTRA WORK ASSIGNMENTS (continued):

Adrian Reyes Antonio, Handle with Care Conference & Training, Special Education, 7/11/22 –7/13/22, not to exceed 30 hours

Carly Rice, Summer School Substitute Teacher, Curriculum, Intervention & Assessment, 6/6/22 – 6/30/22, not to exceed 25 hours

Meghan Robertello, Home and Hospital Instruction, Student Services, 8/10/22 –5/25/23, not to exceed 200 hours

Stacey Saady, Lead Summer School Credit Recovery Teacher, Curriculum, Intervention & Assessment, 7/122 –7/15/22, not to exceed 40 hours

Nancy Sapunor, Academic Intervention Training, DeLaveaga Elementary, 7/25/22 –7/29/22, not to exceed 4 hours

Marliss Shaver, Summer School Substitute Teacher, Special Education, 7/1/22 –7/15/22, not to exceed 5 hours

Matthew Schilz, Math Curriculum & Assessment, Curriculum, Intervention & Assessment, 5/16/22 – 6/15/22, not to exceed 15 hours

Alexandra Simson, New Teacher Mentor, Harbor High, 7/16/22 –12/15/22, not to exceed 2 hours

Ruth Strickland, Home & Hospital Instruction, Special Education, 1/1/22 –6/30/22, not to exceed 77 hours

Elene Thompson, Summer School Substitute Teacher, Special Education, 7/1/22 –7/15/22, not to exceed 8 hours

Jennifer Villarreal, Academic Intervention Training, DeLaveaga Elementary, 7/25/22 –7/29/22, not to exceed 4 hours

Carina Wandel, Summer School Credit Recovery Teacher, Curriculum, Intervention & Assessment, 5/16/22 –6/30/22, not to exceed 158 hours

2021-2022 EXTRA WORK ASSIGNMENTS (continued):

Carina Wandel, Summer School Credit Recovery Teacher, Curriculum, Intervention & Assessment, 7/1/22 –7/15/22, not to exceed 30 hours

Meghan White O’Hagan, Bright Solutions for Dyslexia Training, Special Education, 7/15/22 –8/9/22, not to exceed 12 hours

Carmen Zuniga Martinez, MTG Planning & Develop PBIS Intervention, DeLaveaga Elementary, 6/1/22 –6/30/22, not to exceed 12 hours

SANTA CRUZ CITY SCHOOL DISTRICT

AGENDA ITEM: Classified Personnel Actions

MEETING DATE: August 17, 2022

FROM: Molly Parks, Asst. Superintendent, Human Resources

THROUGH: Kris Munro, Superintendent

RECOMMENDATION:

Approve the classified personnel actions as submitted.

BACKGROUND:

The attached lists of classified personnel actions are submitted in accordance with the District, SCCCE Agreement and the Merit Rules.

This work is in direct support of the following district goals and their corresponding metrics:

Goal #1: All SCCS students will be prepared to successfully access post-secondary college and career opportunities.

Goal #2: SCCS will create positive, engaging school environments that promote the development of cognitive skills and the social-emotional well-being of all students.

Goal #3: We will eliminate the achievement gaps that currently exist between demographic groups within the SCCS student community.

Goal #4: We will develop a highly collaborative, professional culture focused on supporting effective teaching.

CLASSIFIED EMPLOYEE ACTIONS

Reviewed by Director-Classified Personnel: *Keneé Houser 8/9/2022*

• Employment Actions Concerning Regular Assignments •

Probationary (New Hires or Temporary Employees Made Regular):

Avila, Catarina, Food Service Worker I - FS, 3.5 hrs/9 mos, effective 8/10/22

Blackburn, Suzie, Site Program Coordinator - WL, 2 hrs/9 mos, effective 8/10/22

Blank, Nicholas, Athletic Trainer - SCHS, 8 hrs/10 mos, effective 8/2/22

Branoff, Stu, Paraeducator-Academic Intervention - BV, 3.95 hrs/9 mos, effective 8/10/22

Castillo-Musante, Carolyn, Paraeducator & Paraeducator-Academic Intervention - GA, 1.5 hrs/9 mos & 1.5 hrs/9 mos, effective 8/10/22

Chateauvert, Stephanie, Paraeducator-Sped - SHS, 5 hrs/9 mos, effective 8/10/22

Coronado, Margarito, Playground/Recess Coach - GA, 3 hrs/9 mos, effective 8/10/22

Cortes, Abigail, Night Custodian - SHS, 8 hrs/12 mos, effective 6/20/22

Cromer, Alison, Paraeducator-After School - BV, 3.9 hrs/9 mos, effective 8/10/22

Dannehl, John, Paraeducator-Sped - SHS, 5 hrs/9 mos, effective 8/10/22

de Alba Corona, Bruno, Program Coordinator-After School - MH, 3.6 hrs/9 mos, effective 8/1/22

Dickson, Kinsey, Executive Asst I - BS, 8 hrs/12 mos, effective 7/28/22

Dooley, Jared, Paraeducator-Academic Intervention - WL, 3 hrs/9 mos & Yard Duty Monitor - WL, .6 hrs/9 mos, effective 8/10/22

Forbus, Sonya, Paraeducator-Academic Intervention - DL, 3 hrs/9 mos, effective 8/10/22

Gonzales, Christina, Paraeducator-TK - GA, 7 hrs/9 mos, effective 8/10/22

Gonzalez, Alyssa, Paraeducator-Sped - GA, 5 hrs/9 mos, effective 8/10/22

Herman, Marissa, Paraeducator-TK - DL, 7 hrs/9 mos, effective 8/10/22

Hernandez, Marta, Food Service Worker I - FS, 3.5 hrs/9 mos, effective 8/10/22

Hernandez, Rafael, Night Custodian - WL, 8 hrs/12 mos, effective 8/2/22

Honeywell, Katrina, Health Office Assistant - SCHS, 3 hrs/9 mos, effective 8/10/22

Kerner, Kevin, Yard Duty Monitor - DL, 2.5 hrs/9 mos, effective 8/10/22

Limas, Sonia, Paraeducator-Sped - SCHS, 5 hrs/9 mos, effective 8/10/22

McFaddin, Wayne, Paraeducator-Academic Intervention - BMS, 3 hrs/9 mos, effective 8/10/22

Montes Barraga, Mariela, Night Custodian - SC, 8 hrs/12 mos, effective 6/30/22

Morgan, Jon, Director-IT - IT, 8 hrs/12 mos, effective 7/11/22

AGENDA ITEM 8.1.3.2

O'Connell, Dennis, Program Coordinator-After School - GA, 8 hrs/10 mos, effective 8/1/22
Powell, Brooke, Health Office Assistant - WL, 3 hrs/9 mos, effective 8/10/22
Quevedo, Vivian, Paraeducator - BV, 3 hrs/9 mos, and Yard Duty Monitor - BV, .75 hrs/9 mos, effective 8/10/22
Rock, Delayne, Behavior Technician-Sped - BV, 5.2 hrs/9 mos, effective 8/10/22
Rodriguez, Jose, Yard Duty Monitor – DL, 3.2 hrs/9 mos, effective 8/10/22
Ruiz, Miguel, Night Custodian - WL, 8 hrs/12 mos, effective 8/2/22
Sliwinski, Maria, Paraeducator - WL, 3 hrs/9 mos, effective 8/10/22
Struckmeyer, Jake, Campus Safety Supervisor - HHS, 8 hrs/9 mos, effective 8/10/22
Tremblay, David, Library/Media Assistant - HHS, 3.5 hrs/9 mos, effective 8/10/22
Veloz, Hilda, Paraeducator-Academic Intervention - BSS, 3.8 hrs/9 mos, effective 8/10/22
Violago, Timothy, Athletic Trainer - HHS, 8 hrs/10 mos, effective 8/2/22
Walker, Carolyn, Athletic Trainer - SHS, 8 hrs/10 mos, effective 8/2/22
Young, Lori, Program Coordinator-After School - BMS, 3.6 hrs/10 mos, effective 8/1/22
Zamora, Mario, Night Custodian - BSS, 8 hrs/12 mos, effective 6/20/22

Promotion:

Anaya Mendez, Yesenia, from Registrar - HHS, 6 hrs/9 mos, to School Administrative Assistant III - HHS, 8 hrs/11 mos, effective 7/18/22
Cortez, Estevan, from Office Assistant - GA, 3.5 hrs/9 mos, to Registrar - HHS, 6 hrs/9 mos, effective 8/10/22
Delgado, Sandra, from Paraeducator 3 hrs/9 mos, Paraeducator-After School 3.75 hrs/9 mos, and Yard Duty Monitor .75 hrs/9 mos - BV to Paraeducator-TK - BV, 7 hrs/9 mos, effective 8/10/22
Kinley, Diane, from Paraeducator 3 hrs/9 mos and Yard Duty Monitor .6 hrs/9 mos - WL to Paraeducator-TK - WL, 7 hrs/9 mos, effective 8/10/22
Marizette, Gail, from Office Assistant to Attendance Technician - BV, 3.5 hrs/9 mos, effective 8/10/22
Rodriguez, Stephanie, from Office Assistant to Attendance Technician - DL, 3.5 hrs/9 mos, effective 8/10/22
Weizman, Naomi, from Paraeducator-Sped - SHS, 5 hrs/9 mos to School Administrative Assistant II - MHMS, 6 hrs/9 mos, effective 8/10/22
Williams, Julie, from Paraeducator-Sped - HHS, 5 hrs/9 mos to Behavior Technician-Sped - HHS, 6.2 hrs/9 mos, effective 8/10/22

Decrease FTE:

Timar, Amanda, Nutrition Coordinator-FS, from 8 hrs/12 mos to 7 hrs/12 mos, effective 7/1/22

Increase FTE:

Baxley, Leda, Paraeducator-Academic Intervention - HHS, from 3.5 hrs/9 mos to 8 hrs/9 mos, effective 7/1/22

Gonzalez, Amy, Payroll Technician - FI, from 3.8 hrs/12 mos to 6 hrs/12 mos, effective 7/1/22

Luis-Martinez, Citlali, Behavior Technician-SPED - BMS, from 52. hrs/9 mos to 6.5 hrs/9 mos, effective 8/10/22

Perez, Ana, Food Service Worker I - FS, from 3.5 hrs/9 mos to 6 hrs/9 mos, effective 8/10/22

Sturgeon, Rishelle, Career Development Specialist - SPED, from 3.8 hrs/9 mos to 6 hrs/9 mos, effective 8/10/22

Torres Guillen, Reyna, Paraeducator-Academic Intervention - SHS, from 3.5 hrs/9 mos to 8 hrs/9 mos, effective 7/1/22

Wong, Juliette, Paraeducator-After School - BV, from 2.8 hrs/9 mos to 3.9 hrs/9 mos, effective 8/10/22

Add Position:

Perez, Felix, Paraeducator-Sped - WL, 5 hrs/9 mos, effective 8/10/22

Thomas, Amanda, Paraeducator-Sped - BV, 5.6 hrs/9 mos, effective 8/10/22

Increase Calendar:

Geffken, Donna, Program Coordinator-After School - BV, from 8 hrs/9 mos to 8 hrs/10 mos, effective 8/1/22

Reduce FTE:

Thomas, Amanda, Paraeducator-After School - BV, from 3.9 hrs/9 mos to 2.4 hrs/9 mos, effective 8/10/22

Reinstatement:

Hayes, Tricia, Project Coordinator - M/O, 8 hrs/12 mos, effective 7/11/22

Reinstatement/Voluntary Demotion:

Fernandez, Maia, Paraeducator-Sped - SC, 5 hrs/9 mos, effective 7/1/22

Transfer:

Chavez, Audrey, Paraeducator-Sped, 5 hrs/9 mos, from HHS to WL, effective 7/1/22

Nunez, Kathrine, Paraeducator-Sped, 5 hrs/9 mos, from SPED to WL, effective 8/10/22

Transfer & Add Position:

Gonzales, Laura, Health Office Assistant, 3 hrs/9 mos, from BV to GA & add Attendance Technician-GA, 3.5 hrs/9 mos, effective 8/10/22

Transfer & Increase FTE:

Tucker, Stephanie, Paraeducator-Sped, from 3 hrs/9 mos-WL to 3.9 hrs/9 mos-SS, effective 8/10/22

Separation from Position:

Vu, Le, Paraeducator-After School - MH, 2 hrs/9 mos, effective 5/30/22

Separation from Service:

Ancic, Meri, Library/Media Assistant - MH, 7 hrs/9 mos, effective 7/21/22

Juarez, Shaylyn, Food Service Worker I - FS, 3.5 hrs/9 mos, effective 7/21/22

Anderson, Sarah, Paraeducator-Academic Intervention - BMS, 3 hrs/9 mos, effective 6/23/22

Arnold, Katherine, Yard Duty Monitor - WL, .7 hrs/9 mos, effective 7/12/22

Bernardi, Tabitha, Office Assistant - WL, 8 hrs/9 mos, effective 7/22/22

Bonuccelli, Maria, Health Office Assistant - SC, 3 hrs/9 mos, effective 7/15/22

Fisher, Monica, Behavior Technician-Sped - BV, 6.5 hrs/9 mos, effective 8/9/22

Goena, Ana, Paraeducator-Sped - GA, 5 hrs/9 mos, effective 8/5/22

Gonzalez, Nancy, Food Service Worker I - FS, 3.5 hrs/9 mos, effective 8/3/22

Guzman, Severo, Night Custodian - WL, 8 hrs/12 mos, effective 7/14/22

Hassler, Madison, Paraeducator-Academic Intervention - WL, 3 hrs/9 mos, effective 5/31/22

Maldonado, Arlett, Paraeducator-After School - GA, 3.3 hrs/9 mos, effective 7/28/22

Marquez, Hilda, Food Service Worker I - FS, 3.5 hrs/9 mos, effective 6/24/22

Palomo, Ignacio, Night Custodian - SC, 8 hrs/12 mos, effective 6/3/22

Sakellis, Kimberly, Yard Duty Monitor - DL, 2.5 hrs/9 mos, effective 7/27/22

Thompson, Kathleen, Site Accounting Technician - SHS, 5 hrs/10 mos, effective 7/6/22

Ulfvengren, Emma, Paraeducator-After School - BV, 3.9 hrs/9 mos, effective 7/12/22

Zamora, Jasmine, Health Office Assistant - GA, 3 hrs/9 mos, effective 6/13/22

• Limited Term Projects (not to exceed 126 days)/Substitutes •

New Temporary Employees:

Boggs, Mahki, Night Custodian - various, effective 8/1/22

Brandi, Taylor, Paraeducator-Sped - various, effective 6/7/22

Flores, Elliott, Night Custodian - various, effective 6/6/22

Galang, Leolinda, Night Custodian - M/O, not to exceed 16 hrs, 6/10 - 6/13/22

Loftus, Cheyenne, Program Coordinator-After School - BV, effective 8/8/22

Rogers, Lauren, Paraeducator-Sped - ESY, effective 6/6/22

Temporary Employees:

Austin Lane, Katherine, Paraeducator-After School - Curr, not to exceed 150.5 hrs, 5/16 - 6/30/22

Bone, Timothy, Night Custodian - M/O, not to exceed 53 hrs, 5/17 - 6/25/22

Carroll, Laura, Mental Health Specialist - ESY, not to exceed 5 hrs, 7/16 - 8/15/22

Casey, Patrick, School Bus Driver - TR, not to exceed 38.5 hrs, 5/24 - 6/7/22

Castillo-Musante, Carolyn, Behavior Tech-PBIS - Curr, not to exceed 184 hrs, 6/6 - 7/15/22

Cortes, Abigail, Night Custodian - SHS, not to exceed 80 hrs, 5/16 - 6/30/22

Cortes, Abigail, Night Custodian - WL, not to exceed 32 hrs, 5/16 - 6/30/22

Cortes, Abigail, Night Custodian - M/O, not to exceed 40 hrs, 7/1/22 - 6/30/23

Cuttriss, Jessica, Nutrition Outreach Instructional Specialist - FS, not to exceed 200 hrs, 7/1 - 8/9/22

Day Smith, Kiauna, School Administrative Assistant II - MH, not to exceed 2 hrs, 6/28/22

Flores, Elliot, Night Custodian - HHS, not to exceed 80 hrs, 7/16/22 - 6/30/23

Flores, Elliot, Night Custodian - SCHS, not to exceed 600 hrs, 5/16 - 9/15/22

Gembe, Emmanuel, Night Custodian - M/O, not to exceed 100 hrs, 7/1/22 - 6/30/23

Hayes, Tricia, Project Coordinator - M/O, not to exceed 30 hrs, 7/1 - 7/10/22

Perez, Autumn, Behavior Technician-Sped - ESY, not to exceed 27.8 hrs, 6/1 - 6/30/22

Rodriguez, Stephanie, Attendance Technician - DL, not to exceed 80 hrs, 8/1 - 9/15/22

Ryan, Michael, Night Custodian - SHS, not to exceed 50 hrs, 7/1 - 8/15/22

Speka, John, Night Custodian - Curr, not to exceed 180 hrs, 5/30 - 6/30/23

Torres, Moises, Night Custodian - M/O, not to exceed 220 hrs, 7/1/22 - 6/30/23

Waters, Carolyn, Behavior Technician-PBIS - Curr, not to exceed 104 hrs, 6/1 - 6/30/22

Waters, Sierra, Behavior Technician-PBIS - Curr, not to exceed 81 hrs, 5/27 - 6/30/22

Regular Employees (Extra Hours or Limited Term Assignments):

Anaya-Mendez, Yesenia, Registrar - HHS, not to exceed 50 hrs, 5/16 - 6/30/22

Baldwin, Christian, Maintenance Specialist - M/O, not to exceed 192 hrs, 6/30 - 7/1/22

Bennett, Jacqueline, Health Office Assistant - DL, not to exceed 15 hrs, 7/16 - 8/15/22

Bernardi, Tabitha, Administrative Assistant - M/O, not to exceed 24 hrs, 5/16 - 6/15/22

Blanck, Adrian, Night Custodian - M/O, not to exceed 70 hrs, 7/1/22 - 6/30/23

Carrillo Salinas, Pilar, Food Service Worker I - FS, not to exceed 8 hrs, 7/1 - 7/4/22

Carroll, Laura, Mental Health Specialist - ESY, not to exceed 75 hrs, 6/1 - 7/12/22

Carvajal, Soledad, Parent/Community Support Coordinator - DL, not to exceed 20 hrs, 8/9 - 9/15/22

Castellanos, Wanda, Food Service Worker II - FS, not to exceed 165 hrs, 5/31 - 7/13/22

Castillo-Musante, Carolyn, Behavior Technician-PBIS - Curr, not to exceed 152 hrs, 6/6 - 6/30/22

Chavez, Audrey, Paraeducator-Academic Intervention - Curr, not to exceed 122 hrs, 6/6 - 7/15/22

Chavez Cruz, Laura, Food Service Worker I - FS, not to exceed 108 hrs, 5/31 - 7/15/22

Chavez de Avila, Maria, Food Service Worker I - FS, not to exceed 108 hrs, 7/1 - 8/5/22

Crosby, Michael, Maintenance Specialist - M/O, not to exceed 4.5 hrs, 5/26/22

Cusirramos, Mirella, Paraeducator-After School - Curr, not to exceed 253 hrs, 5/27 - 7/15/22

Danielson, Joanna, Food Service Worker III - FS, not to exceed 205 hrs, 5/31 - 8/5/22

Elliott Perkins, Pam, School Admin Assistant II - BMS, not to exceed 30 hrs, 6/1 - 6/30/22

Evans, Sandra, Food Service Worker II - FS, not to exceed 45 hrs, 7/1 - 7/13/22

Fennell, Debbie, Health Office Assistant - BSS, not to exceed 15 hrs, 7/16 - 8/15/22

Fette, Leslie, Paraeducator-Sped - SPED, not to exceed 69.5 hrs, 5/1 - 6/30/22

Forbes, Leticia, Paraeducator-Academic Intervention - Curr, not to exceed 105 hrs, 6/6 - 7/15/22

Gaona, Mireya, Parent/Community Support Coordinator - SHS, not to exceed 8 hrs, 7/16 - 8/15/22

Garcia-Montesdeoc, Yesenia, Paraeducator-After School - Curr, not to exceed 224 hrs, 5/27 - 7/15/22

Gardner, Kelly, Food Service Worker I - FS, not to exceed 108 hrs, 5/31 - 7/4/22

Gonzales, Laura, Health Office Assistant - BV, not to exceed 15 hrs, 7/16 - 8/15/22

Hernandez, Maria V., Behavior Technician-PBIS - Curr, not to exceed 106.5 hrs, 6/1 - 7/15/22

Huerta, Elva, School Bus Driver - TR, not to exceed 120 hrs, 6/1 - 7/15/22

Jones, Jack, Groundskeeper III - M/O, not to exceed 160 hrs, 7/1/22 - 6/30/23

Kemerling, Mark, School Bus Driver - TR, not to exceed 119 hrs, 6/1 - 7/15/22

Kirch, Karla, Paraeducator-Academic Intervention - SHS, not to exceed 6 hrs, 7/16 - 8/15/22

Lamendola, Matthew, School Bus Driver - TR, not to exceed 152 hrs, 6/1 - 7/15/22

Layne, Sean, School Bus Driver - TR, not to exceed 162 hrs, 5/27 - 7/15/22

Lazo, Irwing, Health Office Assistant - MHMS, not to exceed 15 hrs, 7/16 - 8/15/22

Lopez, Areli, Paraeducator-After School - Curr, not to exceed 256 hrs, 5/27 - 7/15/22

Lopez, Teodoro, Day Custodian - M/O, not to exceed 70 hrs, 7/1/22 - 6/30/23

AGENDA ITEM 8.1.3.2

Luis-Martinez, Citlali, Behavior Technician-Sped - ESY, not to exceed 151 hrs, 6/1 - 8/15/22
Martinez, Rosa, Program Coordinator-After School - Curr, not to exceed 296 hrs, 5/16 - 7/15/22
Martinez Garzia, Perla, Behavior Technician-Sped - SPED, not to exceed 2 hrs, 4/16 - 6/30/22
McDonald, Kristin, Mental Health Specialist - Curr, not to exceed 160 hrs, 6/7 - 7/15/22
Medina, Jesus, Campus Safety Supervisor - Curr, not to exceed 12.5 hrs, 6/13 - 6/14/22
Mojica, Anarbol, Night Custodian - HHS, not to exceed 6 hrs, 5/16 - 6/30/22
Montanez, Cory, Health Office Assistant - HHS, not to exceed 15 hrs, 7/16 - 8/15/22
Moreno, Eduardo, Campus Safety Supervisor - Curr, not to exceed 30 hrs 7/1-7/15/22
Novak, Theresa, Paraeducator-Academic Intervention - Curr, not to exceed 15 hrs, 7/1 - 7/15/22
Oxley, Rhonda, School Bus Driver - TR, not to exceed 28 hrs, 5/18 - 6/21/22
Pimentel, Josefina, Campus Safety Supervisor - SHS, not to exceed 8 hrs, 7/16 - 8/15/22
Ramirez, Gustavo, Campus Safety Supervisor - Curr, not to exceed 80 hrs, 6/6 - 6/30/22
Raynal, Vanessa, Food Service Worker III - FS, not to exceed 105 hrs, 7/1 - 8/5/22
Reinero, Eden, Maintenance Specialist - M/O, not to exceed 130 hrs, 6/2 - 6/30/23
Robles-Ruiz, Rodrigo, Day Custodian - M/O, not to exceed 100 hrs, 7/1/22 - 6/30/23
Robles-Vazquez, Jenny, School Admin Assistant III - SHS, not to exceed 15 hrs, 7/16 - 8/15/22
Rodriguez, Stephanie, Attendance Technician - DL, not to exceed 89.5 hrs, 7/1 - 7/29/22
Scott, Matthew, School Bus Driver - TR, not to exceed 132 hrs, 6/1 - 7/15/22
Selder, Simone, Paraeducator-Academic Intervention - Curr, not to exceed 94 hrs, 6/6 - 7/15/22
Serna Castaneda, Jessica, Program Assistant - Curr, not to exceed 194 hrs, 5/23 - 7/15/22
Serna Castaneda, Jessica, Translator - Spt, not to exceed 4.5 hrs, 5/16 - 6/15/22
Sihler, Kris, Instructor/School Bus Driver - TR, not to exceed 2.25 hrs, 5/17 - 5/25/22
Sheinbaum, Grainne, Textbook/Media Assistant - HHS, not to exceed 98 hrs, 7/16 - 12/15/22
Smith, Jennifer, Registrar - SHS, not to exceed 40 hrs, 5/16 - 6/15/22
Thomas, Amanda, Behavior Technician-PBIS - Curr, not to exceed 50.5 hrs, 6/1 - 7/15/22
Torres, Guillen, Reyna, Paraeducator-Academic Intervention - SHS, not to exceed 100 hrs, 7/16 - 8/15/22
Torres Guillen, Reyna, Program Assistant - Curr, not to exceed 233 hrs, 4/16 - 7/15/22
Tremblay, David, Library/Media Assistant - HHS, not to exceed 10 hrs, 8/1 - 12/15/22
Velasco Cuevas, Raymundo, Night Custodian - HHS, not to exceed 4 hrs, 5/16 - 6/30/22
Vincent, Amy, Paraeducator-Academic Intervention - Curr, not to exceed 5.5 hrs, 6/24 - 6/30/22
Weckler, Rosario, Parent/Community Support Coordinator - HHS, not to exceed 12 hrs, 5/16 - 6/30/22

AGENDA ITEM 8.1.3.2

Wofford, Klorissa, Health Office Assistant - BMS, not to exceed 15 hrs, 7/16 - 8/15/22

• **Eligibility Lists Established** •

Health Office Assistant

School Bus Driver

SANTA CRUZ CITY SCHOOL DISTRICT

AGENDA ITEM: Nonpublic School: The Bay School

MEETING DATE: August 17, 2022

FROM: Dorothy Coito, Assistant Superintendent of Educational Services

THROUGH: Kris Munro, Superintendent

RECOMMENDATION:

Approve the attached Nonpublic School contract for continuing services through the 2022-2023 summer and regular school year. *Due to the confidentiality regulations that protect the identity of disabled pupils, the student names have been omitted.*

BACKGROUND:

The Bay School will provide required services for six students in Special Education that cannot be provided in District programs. Services will be rendered through The Bay School and are mandated in each student's Individual Education Plan. Service Period: July 1, 2022, through June 30, 2023.

FISCAL IMPACT:

Not to exceed \$925,304.00 Special Education (Restricted)

This work is in direct support of the following District goals and their corresponding metrics.

Goal #1: All Santa Cruz City Schools students will be prepared to successfully access post-secondary college and career opportunities.

Goal #3: We will eliminate the achievement gaps that currently exist between demographic groups within the SCCS student community

Prepared by Stacy O'Farrell, Director of Special Education

*NONPUBLIC, NONSECTARIAN
SCHOOL/AGENCY SERVICES*

MASTER CONTRACT

2022-2023

MASTER CONTRACT

GENERAL AGREEMENT FOR NONSECTARIAN,
NONPUBLIC SCHOOL AND AGENCY SERVICES

LEA	NORTH SANTA CRUZ COUNTY SELPA
------------	-------------------------------

Contract Year	2022-2023
---------------	-----------

Nonpublic School
 Nonpublic Agency

Type of Contract:

<input checked="" type="checkbox"/>	Master Contract for fiscal year with Individual Service Agreements (ISA) to be approved throughout the term of this contract.
	Individual Master Contract for a specific student incorporating the Individual Service Agreement (ISA) into the terms of this Individual Master Contract specific to a single student.
	Interim Contract: an extension of the previous fiscal years approved contracts and rates. The sole purpose of this Interim Contract is to provide for ongoing funding at the prior year's rates for 90 days at the sole discretion of the LEA. Expiration Date:

When this section is included as part of any Master Contract, the changes specified above shall amend Section 4 – Term of Master Contract.

TABLE OF CONTENTS

I. GENERAL PROVISIONS	Page
1. MASTER CONTRACT	1
2. CERTIFICATION AND LICENSES	1
3. COMPLIANCE WITH LAWS, STATUTES, REGULATIONS	2
4. TERM OF MASTER CONTRACT	2
5. INTEGRATION/CONTINUANCE OF CONTRACT FOLLOWING EXPIRATION OR TERMINATION	3
6. INDIVIDUAL SERVICES AGREEMENT	3
7. DEFINITIONS	4
II. ADMINISTRATION OF CONTRACT	
8. NOTICES	5
9. MAINTENANCE OF RECORDS	5
10. SEVERABILITY CLAUSE	6
11. SUCCESSORS IN INTEREST	6
12. VENUE AND GOVERNING LAW	6
13. MODIFICATIONS AND AMENDMENTS REQUIRED TO CONFORM TO LEGAL AND ADMINISTRATIVE GUIDELINES	6
14. TERMINATION	6
15. INSURANCE	6
16. INDEMNIFICATION	9
17. INDEPENDENT CONTRACTOR	9
18. SUBCONTRACTING	9
19. CONFLICTS OF INTEREST	10
20. NON-DISCRIMINATION	10
III. EDUCATIONAL PROGRAM	
21. FREE AND APPROPRIATE PUBLIC EDUCATION	11
22. GENERAL PROGRAM OF INSTRUCTION	11
23. INSTRUCTIONAL MINUTES	12
24. CLASS SIZE	12
25. CALENDARS	13
26. DATA REPORTING	13
27. LEAST RESTRICTIVE ENVIRONMENT/DUAL ENROLLMENT	14
28. STATEWIDE ACHIEVEMENT TESTING	14
29. MANDATED ATTENDANCE AT LEA MEETINGS	14
30. POSITIVE BEHAVIOR INTERVENTIONS AND SUPPORTS	15
31. STUDENT DISCIPLINE	16
32. IEP TEAM MEETINGS	16
33. SURROGATE PARENTS AND FOSTER YOUTH	17
34. DUE PROCESS PROCEEDINGS	17
35. COMPLAINT PROCEDURES	17
36. STUDENT PROGRESS REPORTS/REPORT CARDS AND ASSESSMENTS	18
37. TRANSCRIPTS	18
38. STUDENT CHANGE OF RESIDENCE	19

39. WITHDRAWAL OF STUDENT FROM PROGRAM	19
40. PARENT ACCESS	19
41. LICENSED CHILDREN'S INSTITUTION CONTRACTORS AND RESIDENTIAL TREATMENT CENTER CONTRACTORS	19
42. STATE MEAL MANDATE	20
43. MONITORING	20
IV. PERSONNEL	
44. CLEARANCE REQUIREMENTS	21
45. STAFF QUALIFICATIONS	21
46. VERIFICATION OF LICENSES, CREDENTIALS AND OTHER DOCUMENTS	22
47. STAFF ABSENCE	23
48. STAFF PROFESSIONAL BEHAVIOR	23
V. HEALTH AND SAFETY MANDATES	
49. HEALTH AND SAFETY	23
50. FACILITIES AND FACILITIES MODIFICATIONS	24
51. ADMINISTRATION OF MEDICATION	24
52. INCIDENT/ACCIDENT REPORTING	24
53. CHILD ABUSE REPORTING	24
54. SEXUAL HARASSMENT	25
55. REPORTING OF MISSING CHILDREN	25
VI. FINANCIAL	
56. ENROLLMENT, CONTRACTING, SERVICE TRACKING, ATTENDANCE REPORTING AND BILLING PROCEDURES	25
57. RIGHT TO WITHHOLD PAYMENT	26
58. PAYMENT FROM OUTSIDE AGENCIES	27
59. PAYMENT FOR ABSENCES	27
60. LEA and/or NONPUBLIC SCHOOL CLOSURE DUE TO EMERGENCY	28
61. INSPECTION AND AUDIT	28
62. RATE SCHEDULE	29
63. DEBARMENT CERTIFICATION	29
EXHIBIT A: RATES	32
EXHIBIT B: INDIVIDUAL SERVICES AGREEMENT	34

2022-2023	CONTRACT NUMBER:
LOCAL EDUCATION AGENCY: <u>North Santa Cruz County SELPA</u>	

NONPUBLIC SCHOOL/AGENCY/RELATED SERVICES PROVIDER: The Bay School

**NONPUBLIC, NONSECTARIAN SCHOOL/AGENCY SERVICES
MASTER CONTRACT**

AUTHORIZATION FOR MASTER CONTRACT AND GENERAL PROVISIONS

1. MASTER CONTRACT

This Master Contract (or “Contract”) is entered into on July 1, 2022, between North Santa Cruz County, hereinafter referred to as the local educational agency ("LEA"), and The Bay School (nonpublic, nonsectarian school or agency), hereinafter referred to as NPS/A or “CONTRACTOR” for the purpose of providing special education and/or related services to students with exceptional needs under the authorization of California Education Code sections 56157, 56361 and 56365 *et seq.* and Title 5 of the California Code of Regulations section 3000 *et seq.*, AB 490 (Chapter 862, Statutes of 2003) and AB 1858 (Chapter 914, Statutes of 2004). It is understood that this agreement does not commit the LEA to pay for special education and/or related services provided to any student, or CONTRACTOR to provide such special education and/or related services, unless and until an authorized LEA representative approves the provision of special education and/or related services by CONTRACTOR.

Upon acceptance of a student, LEA shall submit to CONTRACTOR an Individual Services Agreement (hereinafter referred to as “ISA”). Unless otherwise agreed in writing, these forms shall acknowledge CONTRACTOR’s obligation to provide all relevant services specified in the student’s Individualized Education Program (hereinafter referred to as “IEP”). The ISA shall be executed within ninety (90) days of a student’s enrollment. LEA and CONTRACTOR shall enter into an ISA for each student served by CONTRACTOR. As available and appropriate, the LEA shall make available access to any electronic IEP system and/or electronic database for ISA developing including invoicing.

Unless placement and/or services is made pursuant to an Office of Administrative Hearings (hereinafter referred to as “OAH”) order, a lawfully executed settlement agreement between LEA and parent or authorized by LEA for a transfer student pursuant to California Education Code section 56325, LEA is not responsible for the costs associated with NPS placement or NPS/A services until the date on which an IEP team meeting is convened, the IEP team determines that a NPS placement is appropriate, and the IEP is signed by the student’s parent.

2. CERTIFICATION AND LICENSES

CONTRACTOR shall be certified by the California Department of Education (hereinafter referred to as “CDE”) as a NPS/A. All NPS/A services shall be provided consistent with the area of certification and licensure specified by CDE Certification and as defined in California Education Code, section 56366 *et seq* and within the professional scope of practice of each provider’s license, certification and/or credential. A current copy of CONTRACTOR’s NPS/A certification or a waiver of such certification issued by the CDE pursuant to Education Code section 56366.2 must be provided to LEA on or before the date this Agreement is executed by CONTRACTOR. This Master Contract shall be null and void if such certification or waiver is expired, revoked, rescinded, or otherwise nullified during the effective period of

this Master Contract. Total student enrollment shall be limited to capacity as stated on CDE certification and in Section 24 of the Master Contract.

In addition to meeting the certification requirements of the State of California, a CONTRACTOR that operates a program outside of this State shall be certified and all staff persons providing services to pupils shall be certified and/or licensed by that state to provide, respectively, special education and related services and designated instruction and related services to pupils under the federal Individuals with Disabilities Education Act (20 U.S.C. Sec. 1400 et seq.).

If CONTRACTOR is a licensed children's institution (hereinafter referred to as "LCI"), CONTRACTOR shall be licensed by the state, or other public agency having delegated authority by contract with the state to license, to provide nonmedical care room and board to children, including, but not limited to, individuals with exceptional needs. The LCI must also comply with all licensing requirements relevant to the protection of the child, and have a special permit, if necessary, to meet the needs of each child so placed. If the CONTRACTOR operates a program outside of this State, CONTRACTOR must obtain all required licenses from the appropriate licensing agency in both California and in the state where the LCI is located.

With respect to CONTRACTOR's certification, failure to notify the LEA and CDE in writing of any changes in: (1) credentialed/licensed staff; (2) ownership; (3) management and/or control of the agency; (4) major modification or relocation of facilities; or (5) significant modification of the program may result in the suspension or revocation of CDE certification and/or suspension or termination of this Master Contract by the LEA.

3. COMPLIANCE WITH LAWS, STATUTES, REGULATIONS

During the term of this Master Contract, unless otherwise agreed, CONTRACTOR shall comply with all applicable federal, state, and local statutes, laws, ordinances, rules, policies and regulations. CONTRACTOR shall also comply with all applicable LEA policies and procedures unless, taking into consideration all of the surrounding facts and circumstances, a policy or policies or a portion of a policy does not reasonably apply to CONTRACTOR. CONTRACTOR hereby acknowledges and agrees that it accepts all risks and responsibilities for its failure to comply with LEA policies and shall indemnify LEA under the provisions of Section 16 of this Agreement for all liability, loss, damage and expense (including reasonable attorneys' fees) resulting from or arising out of CONTRACTOR's failure to comply with applicable LEA policies (e.g., those policies relating to; the provision of special education and/or related services, facilities for individuals with exceptional needs, student enrollment and transfer, student inactive status, corporal punishment, student discipline, and positive behavior interventions).

CONTRACTOR acknowledges and understands that LEA may report to the CDE any violations of the provisions of this Master Contract; and that this may result in the suspension and/or revocation of CDE nonpublic school/agency certification pursuant to California Education Code section 56366.4(a).

4. TERM OF MASTER CONTRACT

The term of this Master Contract shall be from July 1, 2022 to June 30, 2023 (Title 5 California Code of Regulations section 3062(a)) unless otherwise stated. Neither the CONTRACTOR nor the LEA is required to renew this Master Contract in subsequent contract years. The parties acknowledge that any subsequent Master Contract is to be re-negotiated prior to June 30, 2023. In the event the contract negotiations are not agreed to by June 30th, the most recently executed Master Contract will remain in effect for 90 days. (Title 5 California Code of Regulations section 3062(d)) No Master Contract will be offered unless and until all of the contracting requirements have been satisfied. The offer of a Master Contract to a CONTRACTOR is at the sole discretion of the LEA.

The provisions of this Master Contract apply to CONTRACTOR and any of its employees or independent contractors. Notice of any change in CONTRACTOR's ownership or authorized representative shall be

provided in writing to LEA within thirty (30) calendar days of change of ownership or change of authorized representative.

5. INTEGRATION/CONTINUANCE OF CONTRACT FOLLOWING EXPIRATION OR TERMINATION

This Master Contract includes each ISA and they are incorporated herein by this reference. This Master Contract supersedes any prior or contemporaneous written or oral understanding or agreement. This Master Contract may be amended only by written amendment executed by both parties.

CONTRACTOR shall provide the LEA with information as requested in writing to secure a Master Contract or a renewal.

At a minimum, such information shall include copies of current teacher credentials and clearance, insurance documentation and CDE certification. The LEA may require additional information as applicable. If the application packet is not completed and returned to District, no Master Contract will be issued. If CONTRACTOR does not return the Master Contract to LEA duly signed by an authorized representative within ninety (90) calendar days of issuance by LEA, the new contract rates will not take effect until the newly executed Master Contract is received by LEA and will not be retroactive to the first day of the new Master Contract's effective date. If CONTRACTOR fails to execute the new Master Contract within such ninety-day period, all payments shall cease until such time as the new Master Contract for the current school year is signed and returned to LEA by CONTRACTOR. (California Education Code section 56366(c)(1) and (2)). In the event that this Master Contract expires or terminates, CONTRACTOR shall continue to be bound to all of the terms and conditions of the most recent executed Master Contract between CONTRACTOR and LEA for so long as CONTRACTOR is servicing authorized students at the discretion of the LEA.

6. INDIVIDUAL SERVICES AGREEMENT ("ISA")

This Agreement shall include an ISA developed for each student to whom CONTRACTOR is to provide special education and/or related services. An ISA shall only be issued for students enrolled with the approval of the LEA pursuant to Education Code section 56366 (a)(2)(A). An ISA may be effective for more than one contract year provided that there is a concurrent Master Contract in effect. In the event that this Master Contract expires or terminates, CONTRACTOR, shall continue to be bound to all of the terms and conditions of the most recent executed ISAs between CONTRACTOR and LEA for so long as CONTRACTOR is servicing authorized students.

Any and all changes to a student's educational placement/program provided under this Master Contract and/or an ISA shall be made solely on the basis of a revision to the student's IEP or by written agreement between the parent and LEA. At any time during the term of this Master Contract, a student's parent, CONTRACTOR, or LEA may request a review of a student's IEP subject to all procedural safeguards required by law.

Unless otherwise provided in this Master Contract, the CONTRACTOR shall provide all services specified in the IEP unless the CONTRACTOR and the LEA agree otherwise in the ISA. (California Education Code sections 56366(a) (5) and 3062(e)). In the event the CONTRACTOR is unable to provide a specific service at any time during the life of the ISA, the CONTRACTOR shall notify the LEA in writing within five (5) business days of the last date a service was provided. CONTRACTOR shall provide any and all subsequent compensatory service hours awarded to student as a result of lack of provision of services while student was served by the NPS/A.

If a parent or LEA contests the termination of an ISA by initiating a due process proceeding with the OAH, CONTRACTOR shall abide by the "stay-put" requirement of state and federal law unless the

parent agrees otherwise or an Interim Alternative Educational Setting is deemed lawful and appropriate by LEA or OAH consistent with Section 1415 (k)(1)(7) of Title 20 of the United States Code. CONTRACTOR shall adhere to all LEA requirements concerning changes in placement.

Disagreements between LEA and CONTRACTOR concerning the formulation of an ISA or the Master Contract may be appealed to the County Superintendent of Schools of the County where the LEA is located, or the State Superintendent of Public Instruction pursuant to the provisions of California Education Code section 56366(c) (2).

7. DEFINITIONS

The following definitions shall apply for purposes of this contract:

- a. The term “CONTRACTOR” means a nonpublic, nonsectarian school/agency certified by the California Department of Education and its officers, agents and employees.
- b. The term “authorized LEA representative” means a LEA administrator designated to be responsible for NPS/A. It is understood, a representative of the Special Education Local Plan Area (SELPA) of which the LEA is a member is an authorized LEA representative in collaboration with the LEA. The LEA maintains sole responsibility for this Contract, unless otherwise specified in this Contract.
- c. The term “credential” means a valid credential, life diploma, permit, or document in special education or pupil personnel services issued by, or under the jurisdiction of, the State Board of Education if issued prior to 1970 or the California Commission on Teacher Credentialing, which entitles the holder thereof to perform services for which certification qualifications are required as defined in Title 5 of the California Code of Regulations section 3001(g).
- d. The term “qualified” means that a person holds a certificate, permit or other document equivalent to that which staff in a public school are required to hold to provide special education and designated instruction and services and has met federal and state certification, licensing, registration, or other comparable requirements which apply to the area in which he or she is providing special education or related services, including those requirements set forth in Title 34 of the Code of Federal Regulations sections 200.56 and 200.58, and those requirements set forth in Title 5 of the California Code of Regulations Sections 3064 and 3065, and adheres to the standards of professional practice established in federal and state law or regulation, including the standards contained in the California Business and Professions Code.

Nothing in this definition shall be construed as restricting the activities in services of a graduate needing direct hours leading to licensure, or of a student teacher or intern leading to a graduate degree at an accredited or approved college or university, as authorized by state laws or regulations. (Title 5 of the California Code of Regulations Section 3001 (r)).

- e. The term “license” means a valid non-expired document issued by a licensing agency within the Department of Consumer Affairs or other state licensing office authorized to grant licenses and authorizing the bearer of the document to provide certain professional services or refer to themselves using a specified professional title including but not limited to mental health and board and care services at a residential placement. If a license is not available through an appropriate state licensing agency, a certificate of registration with the appropriate professional organization at the national or state level which has standards established for the certificate that are equivalent to a license shall be deemed to be a license as defined in Title 5 of the California Code of Regulations section 3001(l).
- f. “Parent” means:
 - i. a biological or adoptive parent; unless the biological or adoptive parent does not have legal authority to make educational decisions for the child,

- ii. a guardian generally authorized to act as the child’s parent or authorized to make educational decisions for the child,
- iii. an individual acting in the place of a biological or adoptive parent, including a grandparent, stepparent, or other relative with whom the child lives, or an individual who is legally responsible for the child’s welfare,
- iv. a surrogate parent,
- v. a foster parent if the authority of the biological or adoptive parent to make educational decisions on the child’s behalf has been specifically limited by court order in accordance with Code of Federal Regulations 300.30(b)(1) or (2).

Parent does not include the state or any political subdivision of government or the NPS/A under contract with the LEA for the provision of special education or designated instruction and services for a child. (California Education Code section 56028).

- g. The term “days” means calendar days unless otherwise specified.
- h. The phrase “billable day” means a school day in which instructional minutes meet or exceed those in comparable LEA programs.
- i. The phrase “billable day of attendance” means a school day as defined in California Education Code Section 46307, in which a student is in attendance and in which instructional minutes meet or exceed those in comparable LEA programs unless otherwise stipulated in an IEP or ISA.
- j. It is understood that the term “Master Contract” also means “Contract” and is referred to as such in this document.

ADMINISTRATION OF CONTRACT

8. NOTICES

All notices provided for by this Contract shall be in writing. Notices shall be mailed or delivered by hand and shall be effective as of the date of receipt by addressee.

All notices mailed to LEA shall be addressed to the person and address as indicated on the signature page of this Master Contract. Notices to CONTRACTOR shall be addressed as indicated on signature page of this Master Contract.

9. MAINTENANCE OF RECORDS

All records shall be maintained by CONTRACTOR as required by state and federal laws and regulations. Notwithstanding the foregoing sentence, CONTRACTOR shall maintain all records for at least five (5) years after the termination of this Master Contract. For purposes of this Master Contract, “records” shall include, but not be limited to student records as defined by California Education Code section 49061(b) including electronically stored information; cost data records as set forth in Title 5 of the California Code of Regulations section 3061; registers and roll books of teachers and/or daily service providers; daily service logs and notes and other documents used to record the provision of related services including supervision; daily service logs and notes used to record the provision of services provided through additional instructional assistants, NPA behavior intervention aides, and bus aides; behavior emergency reports (BER); incident reports; notification of injuries; absence verification records (parent/doctor notes, telephone logs, and related documents) if the CONTRACTOR is funded for excused absences, however, such records are not required if positive attendance is required; bus rosters; staff lists specifying credentials held and documents evidencing other staff qualifications, social security numbers, dates of hire, and dates of termination; records of employee training and certification, staff time sheets; non-paid staff and volunteer sign-in sheets; transportation and other related services subcontracts; school calendars; bell/class schedules when applicable; liability and worker’s compensation insurance policies; state NPS/A certifications by-laws; lists of current board of directors/trustees, if incorporated; statement of income and

expenses; general journals; cash receipts and disbursement books; general ledgers and supporting documents; documents evidencing financial expenditures; federal/state payroll quarterly reports; evidence of electronic payments; and bank statements and canceled checks or facsimile thereof.

CONTRACTOR shall maintain student records in a secure location to ensure confidentiality and prevent unauthorized access. CONTRACTOR shall maintain a current list of the names and positions of CONTRACTOR's employees who have access to confidential records. CONTRACTOR shall maintain an access log for each student's record which lists all persons, agencies, or organizations requesting or receiving information from the record. Such log shall be maintained as required by California Education Code section 49064 and include the name, title, agency/organization affiliation, date/time of access for each individual requesting or receiving information from the student's record, and a description of the record(s) provided. Such log needs to record access to the student's records by: (a) the student's parent; (b) an individual to whom written consent has been executed by the student's parent; or (c) employees of LEA or CONTRACTOR having a legitimate educational interest in requesting or receiving information from the record. CONTRACTOR/LEA shall maintain copies of any written parental concerns granting access to student records. For purposes of this paragraph, "employees of LEA or CONTRACTOR" do not include subcontractors. CONTRACTOR shall grant the following access to student records, (a) the student's parent; (b) employees of LEA or CONTRACTOR having a legitimate educational interest in requesting or receiving information from the record, and comply with parents' requests for copies of student records, as required by state and federal laws and regulations. CONTRACTOR agrees, in the event of school or agency closure, to forward student records within ten (10) business days to LEA. These shall include, but not limited to, current transcripts, IEP/IFSPs, BER's, incident reports, notification of injuries and all other relevant reports. LEA and/or SELPA shall have access to and receive copies of any and all records upon request within five (5) business days.

10. SEVERABILITY CLAUSE

If any provision of this agreement is held, in whole or in part, to be unenforceable for any reason, the remainder of that provision and of the entire agreement shall be severable and remain in effect.

11. SUCCESSORS IN INTEREST

This contract binds CONTRACTOR's successors and assignees. CONTRACTOR shall notify the LEA of any change of ownership or corporate control.

12. VENUE AND GOVERNING LAW

The laws of the State of California shall govern the terms and conditions of this contract with venue in the County where the LEA is located.

13. MODIFICATIONS AND AMENDMENTS REQUIRED TO CONFORM TO LEGAL AND ADMINISTRATIVE GUIDELINES

This Master Contract may be modified or amended by the LEA to conform to administrative and statutory guidelines issued by any state, federal or local governmental agency. The party seeking such modification shall provide the LEA and/or CONTRACTOR thirty (30) days' notice of any such changes or modifications made to conform to administrative or statutory guidelines and a copy of the statute or regulation upon which the modification or changes are based.

14. TERMINATION

This Master Contract or ISA may be terminated for cause. The cause shall not be the availability of a public class initiated during the period of the contract unless the parent agrees to the transfer of the student to the public school program at an IEP team meeting. To terminate the contract either party shall give no less than twenty (20) days prior written notice (California Education Code section 56366(a)(4)). At the time of termination, CONTRACTOR shall provide to LEA any and all documents

CONTRACTOR is required to maintain under this Master Contract. ISAs are void upon termination of this Master Contract, as provided in Section 5 or 6. CONTRACTOR or LEA may terminate an ISA for cause. To terminate the ISA, either party shall give twenty (20) days prior written notice.

15. INSURANCE

CONTRACTOR shall, at CONTRACTOR'S sole cost and expense, maintain in full force and effect, during the term of this Contract, the following insurance coverage from a California licensed and/or admitted insurer with an A minus (A-), VII, or better rating from A.M. Best, sufficient to cover any claims, damages, liabilities, costs and expenses (including counsel fees) arising out of or in connection with CONTRACTOR's fulfillment of any of its obligations under this Agreement or either party's use of the work or any component or part thereof:

PART I - INSURANCE REQUIREMENTS FOR NONPUBLIC SCHOOLS AND AGENCIES

- A. **Commercial General Liability Insurance**, including both bodily injury and property damage, with limits as follows:

\$2,000,000 per occurrence
\$ 500,000 fire damage
\$ 5,000 medical expenses
\$1,000,000 personal & adv. Injury
\$3,000,000 general aggregate
\$2,000,000 products/completed operations aggregate

The policy may not contain an exclusion for coverage of claims arising from claims for sexual molestation or abuse. In the event that CONTRACTOR's policy should have an exclusion for sexual molestation or abuse claims, then CONTRACTOR shall be required to procure a supplemental policy providing such coverage.

- B. **Workers' Compensation Insurance** in accordance with provisions of the California Labor Code adequate to protect the CONTRACTOR from claims that may arise from its operations pursuant to the Workers' Compensation Act (Statutory Coverage). The Workers' Compensation Insurance coverage must also include Employers Liability coverage with limits of \$1,000,000/\$1,000,000/\$1,000,000.
- C. **Commercial Auto Liability Insurance** for all owned, non-owned or hired automobiles with a \$1 million combined single limit.

If no owned automobiles, then only hired and non-owned is required.

If CONTRACTOR uses a vehicle to travel to/from school sites, between schools and/or to/from students' homes or other locations as approved service locations by the LEA, CONTRACTOR must comply with State of California auto insurance requirements.

- D. **Errors & Omissions (E & O)/Malpractice (Professional Liability) coverage**, including Sexual Molestation and Abuse coverage, unless that coverage is afforded elsewhere in the Commercial General Liability policy by endorsement or separate policy, with the following limits:

\$1,000,000 per occurrence
\$2,000,000 general aggregate

- E. CONTRACTOR, upon execution of this Contract and periodically thereafter upon request, shall furnish the LEA with certificates of insurance evidencing such coverage. The certificate

of insurance shall include a ten (10) day non-renewal notice provision. The Commercial General Liability and Automobile Liability policy shall name the LEA and the Board of Education additional insured's premiums on all insurance policies and shall be paid by CONTRACTOR and shall be deemed included in CONTRACTOR's obligations under this contract at no additional charge.

- F. Any deductibles or self-insured retentions above \$100,000 must be declared to and approved by the LEA. At its option, LEA may require the CONTRACTOR, at the CONTRACTOR's sole cost, to: (a) cause its insurer to reduce to levels specified by the LEA or eliminate such deductibles or self-insured retentions with respect to the LEA, its officials and employees, or (b) procure a bond guaranteeing payment of losses and related investigation.
- G. For any claims related to the services performed in connection with this Master Contract, the CONTRACTOR's insurance coverage shall be the primary insurance with respect to the LEA, its subsidiaries, officials and employees. Any insurance or self-insurance maintained by the LEA, its subsidiaries, officials and employees shall be excess of the CONTRACTOR's insurance and shall not contribute with it.
- H. All Certificates of Insurance must reference the contract number, name of the school or agency submitting the certificate, and the location of the school or agency submitting the certificate on the certificate.

PART II - INSURANCE REQUIREMENTS FOR NONPUBLIC SCHOOLS AFFILIATED WITH A RESIDENTIAL TREATMENT FACILITY ("RTC")

When CONTRACTOR is a NPS affiliated with a **residential treatment center (NPS/RTC)**, the following insurance policies are required:

- A. **Commercial General Liability** including both bodily injury and property damage, with limits as follows:

\$3,000,000 per occurrence
\$6,000,000 in General Aggregate.

The policy shall be endorsed to name the LEA and the Board of Education as *named* additional insured and shall provide specifically that any insurance carried by the LEA which may be applicable to any claims or loss shall be deemed excess and the RTC's insurance primary despite any conflicting provisions in the RTC's policy. Coverage shall be maintained with no Self-Insured Retention above \$100,000 without the prior written approval of the LEA.

- B. **Workers' Compensation Insurance** in accordance with provisions of the California Labor Code adequate to protect the RTC from claims that may arise from its operations pursuant to the Workers' Compensation Act (Statutory Coverage). The Workers' Compensation Insurance coverage must also include Employers Liability coverage with limits of \$1,000,000/\$1,000,000/\$1,000,000.
- C. **Commercial Auto Liability** coverage with limits of \$1,000,000 Combined Single Limit per Occurrence if the RTC does not operate a student bus service. If the RTC provides student bus services, the required coverage limit is \$5,000,000 Combined Single Limit per Occurrence.
- D. **Fidelity Bond or Crime Coverage** shall be maintained by the RTC to cover all employees who process or otherwise have responsibility for RTC funds, supplies, equipment or other assets. Minimum amount of coverage shall be \$250,000 per occurrence, with no self-insured retention.

- E. **Professional Liability/Errors & Omissions/Malpractice** coverage with minimum limits of \$3,000,000 per occurrence and \$6,000,000 general aggregate.
- F. **Sexual Molestation and Abuse Coverage**, unless that coverage is afforded elsewhere in the Commercial General Liability or Professional liability policy by endorsement, with minimum limits of \$3,000,000 per occurrence and \$6,000,000 general aggregate.

If LEA or CONTRACTOR determines that a change in insurance coverage obligations under this section is necessary, either party may reopen negotiations to modify the insurance obligations.

16. **INDEMNIFICATION**

CONTRACTOR shall defend, hold harmless and indemnify LEA and its governing board, officers, administrators, agents, employees, independent contractors, subCONTRACTORS, consultants, and other representatives, from all liabilities and claims for damage for death, sickness, or injury to any person(s) or damage to any property, including reasonable attorney's fees and costs, from any cause whatsoever arising from or connected with its service hereunder, whether or not resulting from the negligence of CONTRACTOR, its agents or employees. CONTRACTOR shall save harmless and indemnify and defend LEA and its governing board, officers, agents and employees from all damages of every nature and description proximately caused by negligent or willful acts or omissions by CONTRACTOR, its agents or employees in the course of rendering service(s) under this Agreement.

LEA shall defend, hold harmless and indemnify CONTRACTOR and its governing board, officers, administrators, agents and employees from all liabilities and claims for damage for death, sickness, or injury to any person(s) or damage to any property, including, without limitation all consequential damages, from any cause whatsoever arising from or connected with its service hereunder, whether or not resulting from the negligence of LEA, its agents or employees. LEA shall save harmless and indemnify and defend CONTRACTOR and its governing board, officers, administrators, agents and employees from all damages of every nature and description proximately caused by negligent or willful acts of omissions by LEA, its agents or employees in the course of rendering service(s) under Contract.

Notwithstanding any contrary provisions herein, both parties agree that it retains legal responsibility for its own actions in complying with any and all obligations it has under state and federal law and will not be indemnified for the same.

17. **INDEPENDENT CONTRACTOR**

Nothing herein contained will be construed to imply a joint venture, partnership or principal-agent relationship between the LEA and CONTRACTOR. CONTRACTOR shall provide all services under this Contract as an independent contractor, and neither party shall have the authority to bind or make any commitment on behalf of the other. Nothing contained in this Contract shall be deemed to create any association, partnership, joint venture or relationship of principal and agent, master and servant, or employer and employee between the parties or any affiliates of the parties, or between the LEA and any individual assigned by CONTRACTOR to perform any services for the LEA.

If the LEA is determined to be a partner, joint venture, co-principle, employer or co-employer of CONTRACTOR, CONTRACTOR shall indemnify and hold harmless the LEA from and against any and all claims for loss, liability, or damages arising from that determination, as well as any expenses, costs, taxes, penalties and interest charges incurred by the LEA as a result of that holding.

18. **SUBCONTRACTING**

CONTRACTOR shall provide written notification to LEA before subcontracting for special education and/or related services pursuant to this Master Contract. In the event LEA determines that it can provide the subcontracted service(s) at a lower rate, LEA may elect to provide such service(s). If LEA elects to

provide such service(s), LEA shall provide written notification to CONTRACTOR within five (5) days of receipt of CONTRACTOR's original notice and CONTRACTOR shall not subcontract for said service(s).

CONTRACTOR shall incorporate all of the provisions of this Master Contract in all subcontracts, to the fullest extent reasonably possible. Furthermore, when CONTRACTOR enters into subcontracts for the provision of special education and/or related services (including, but not limited to, transportation) for any student, CONTRACTOR shall cause each subcontractor to procure and maintain insurance during the term of each subcontract. Such subcontractor's insurance shall comply with the provisions of Section 15. Each subcontractor shall furnish the LEA with original endorsements and certificates of insurance effecting coverage required by Section 15. The endorsements are to be signed by a person authorized by that insurer to bind coverage on its behalf. The endorsements are to be on forms as required by the LEA. All endorsements are to be received and approved by the LEA before the subcontractor's work commences. The Commercial General Liability and Automobile Liability policies shall name the LEA/SELPA and the LEA Board of Education as additional insured.

As an alternative to the LEA's forms, a subcontractor's insurer may provide complete, certified copies of all required insurance policies, including endorsements affecting the coverage required by this Master Contract. All Certificates of Insurance must reference the LEA contract number, name of the school or agency submitting the certificate, indication if NPS or NPA, and the location of the school or agency submitting the certificate. In addition, all subcontractors must meet the requirements as contained in Section 45 Clearance Requirements and Section 46 Staff Qualifications of this Master Contract.

19. CONFLICTS OF INTEREST

CONTRACTOR shall provide to LEA upon request a copy of its current bylaws and a current list of its Board of Directors (or Trustees), if it is incorporated. CONTRACTOR and any member of its Board of Directors (or Trustees) shall disclose any relationship with LEA that constitutes or may constitute a conflict of interest pursuant to California Education Code section 56042 and Government Code Section 1090 including, but not limited to, employment with LEA, provision of private party assessments and/or reports, and attendance at IEP team meetings acting as a student's advocate. Pursuant to California Education code section 56042, an attorney or advocate for a parent of an individual with exceptional needs shall not recommend placement at CONTRACTOR's facility if the attorney or advocate is employed or contracted by the CONTRACTOR, or will receive a benefit from the CONTRACTOR, or otherwise has a conflict of interest.

The LEA shall neither execute an ISA with CONTRACTOR nor amend an existing ISA for a student when a recommendation for special education and/or related services is based in whole or in part on assessment(s) or reports provided by CONTRACTOR to the student without prior written authorization by LEA. This paragraph shall apply to CONTRACTOR regardless of when an assessment is performed or a report is prepared (i.e., before or after the student is enrolled in CONTRACTOR's school/agency) or whether an assessment of the student is performed or a report is prepared in the normal course of the services provided to the student by CONTRACTOR. To avoid conflict of interest, and in order to ensure the appropriateness of an Independent Educational Evaluation (hereinafter referred to as "IEE") and its recommendations, the LEA may not fund an IEE by an evaluator who provides ongoing service(s) or is sought to provide service(s) to the student for whom the IEE is requested. Likewise, the LEA may not fund services through the evaluator whose IEE the LEA agrees to fund. When no other appropriate assessor is available, LEA may request and if CONTRACTOR agrees, the CONTRACTOR may provide an IEE.

When CONTRACTOR is a NPA, CONTRACTOR acknowledges that its authorized representative has read and understands Education Code section 56366.3 which provides, in relevant part, that no special education and/or related services provided by CONTRACTOR shall be paid for by LEA if provided by an individual who is or was an employee of LEA within the three hundred and sixty-five (365) days prior to executing this contract. This provision does not apply to any person who is able to provide designated instruction and services during the extended school year because he or she is otherwise employed for up to ten months of the school year by LEA.

CONTRACTOR shall not admit a student living within the jurisdictional boundaries of the LEA on a private pay or tuition free “scholarship” basis and concurrently or subsequently advise/request parent(s) to pursue funding for the admitted school year from the LEA through due process proceedings.

20. NON-DISCRIMINATION

CONTRACTOR shall not, in employment or operation of its programs, unlawfully discriminate on the basis of gender, nationality, national origin, ancestry, race, color, ethnicity, ethnic group affiliation, religion, age, marital status, pregnancy or parental status, sex, sexual orientation, gender, gender identity or expression, physical or mental disability, genetic information or any other classification protected by federal or state law or the perception of one or more of such characteristics or association with a person or group with one or more of these actual or perceived characteristics.

EDUCATIONAL PROGRAM

21. FREE AND APPROPRIATE PUBLIC EDUCATION (FAPE)

The LEA shall provide CONTRACTOR with a copy of the IEP including the Individualized Transition Plan (hereinafter referred to as “ITP”) of each student served by CONTRACTOR. CONTRACTOR shall provide special education and/or related services (including transition services) to each student within the NPS/A consistent with the student’s IEP and as specified in the ISA. If CONTRACTOR is a NPS, CONTRACTOR shall not accept a student if it cannot provide or ensure the provision of the services outlined in the student’s IEP. If student services are provided by a third party (i.e. Related Services Provider), CONTRACTOR shall notify LEA if provision of services cease.

Unless otherwise agreed to between CONTRACTOR and LEA, CONTRACTOR shall be responsible for the provision of all appropriate supplies, equipment, and/or facilities, as specified in the student’s IEP and ISA. CONTRACTOR shall make no charge of any kind to parents for special education and/or related services as specified in the student’s IEP and ISA (including, but not limited to, screenings, assessments, or interviews that occur prior to or as a condition of the student’s enrollment under the terms of this Master Contract). LEA shall provide low incidence equipment for eligible students with low incidence disabilities when specified in the student’s IEP and ISA. Such equipment remains the property of the SELPA/LEA and shall be returned to the SELPA/LEA when the IEP team determines the equipment is no longer needed or when the student is no longer enrolled in the NPS. CONTRACTOR shall ensure that facilities are adequate to provide LEA students with an environment which meets all pertinent health and safety regulations. CONTRACTOR may charge a student’s parent(s) for services and/or activities not necessary for the student to receive a free appropriate public education after: (a) written notification to the student’s parent(s) of the cost and voluntary nature of the services and/or activities; and (b) receipt by the LEA of the written notification and a written acknowledgment signed by the student’s parent(s) of the cost and voluntary nature of the services and/or activities. CONTRACTOR shall adhere to all LEA requirements concerning parent acknowledgment of financial responsibility.

Voluntary services and/or activities not necessary for the student to receive a free appropriate public education shall not interfere with the student’s receipt of special education and/or related services as specified in the student’s IEP and ISA unless the LEA, CONTRACTOR, and PARENT agree otherwise in writing.

22. GENERAL PROGRAM OF INSTRUCTION

All NPS/A services shall be provided consistent with the area of certification specified by CDE Certification and as defined in California Education Code section 56366 *et seq.*...

When CONTRACTOR is a NPS, CONTRACTOR’s general program of instruction shall: (a) utilize evidence-based practices and be consistent with LEA’s standards regarding the particular course of study

and curriculum; (b) include curriculum that addresses mathematics, literacy and the use of educational, assistive technology and transition services; (c) be consistent with CDE's standards regarding the particular course of study and curriculum; (d) provide the services as specified in the student's IEP and ISA. Students shall have access to: (a) State Board of Education (SBE) - adopted Common Core State Standards ("CCSS") for curriculum and the same instructional materials for kindergarten and grades 1 to 8, inclusive; and provide standards – aligned core curriculum and instructional materials for grades 9 to 12, inclusive, used by an LEA, that contracts with the NPS: (b) college preparation courses; (c) extracurricular activities, such as art, sports, music and academic clubs; (d) career preparation and vocational training, consistent with transition plans pursuant to state and federal law and; (e) supplemental assistance, including individual academic tutoring, psychological counseling, and career and college counseling.

When CONTRACTOR serves students in grades 9 through 12 inclusive, LEA shall provide to CONTRACTOR a specific list of the course requirements to be satisfied by the CONTRACTOR leading toward graduation or completion of LEA's diploma requirements. CONTRACTOR shall not award a high school diploma to students who have not successfully completed all of the LEA's graduation requirements.

When CONTRACTOR is a NPA and/or related services provider, CONTRACTOR's general program of instruction and/or services shall utilize evidence-based practices and be consistent with LEA and CDE guidelines and certification, and provided as specified in the student's IEP and ISA. The NPA providing Behavior Intervention services shall develop a written plan that specifies the nature of their NPA service for each student within thirty (30) days of enrollment and shall be provided in writing to the LEA. School-based services may not be unilaterally converted by CONTRACTOR to a substitute program or provided at a location not specifically authorized by the IEP team. Except for services provided by a CONTRACTOR that is a Licensed Children's Institution (LCI), all services not provided in the school setting require the presence of a parent, guardian or adult caregiver during the delivery of services, provided such guardian or caregiver have a signed authorization by the parent or legal guardian to authorize emergency services as requested. LCI CONTRACTORS shall ensure that appropriate and qualified residential or clinical staff is present during the provision of services under this Master Contract. CONTRACTOR shall immediately notify LEA in writing if no parent, guardian or adult caregiver is present. CONTRACTOR shall provide to LEA a written description of the services and location provided prior to the effective date of this Master Contract. CONTRACTORS providing Behavior Intervention services must have a trained behaviorist or trained equivalent on staff. It is understood that Behavior Intervention services are limited per CDE Certification and do not constitute as an instructional program.

When CONTRACTOR is a NPA, CONTRACTOR shall not provide transportation nor subcontract for transportation services for students unless the LEA and CONTRACTOR agree otherwise in writing.

23. INSTRUCTIONAL MINUTES

When CONTRACTOR is a NPS, the total number of instructional minutes per school day provided by CONTRACTOR shall be at least equivalent to the number of instructional minutes per school day provided to students at like grade level attending LEA schools and shall be specified in the student's ISA developed in accordance with the student's IEP.

For students in grades kindergarten through 12 inclusive, unless otherwise specified in the student's IEP and ISA, the number of instructional minutes, excluding breakfast, recess, lunch and passing time shall be at the same level that Ed. Code prescribes for the LEA.

The total number of annual instructional minutes shall be at least equivalent to the total number of annual instructional minutes provided to students attending LEA schools in like grade level unless otherwise specified in the student's IEP.

When CONTRACTOR is a NPA and/or related services provider, the total number of minutes per school day provided by CONTRACTOR shall be specified in the student's ISA developed in accordance with the student's IEP.

24. CLASS SIZE

When CONTRACTOR is a NPS, CONTRACTOR shall ensure that class size shall not exceed a ratio of one teacher per twelve (12) students, unless CONTRACTOR and LEA agree otherwise in writing. Upon prior written approval by an authorized LEA representative, class size may be temporarily increased by a ratio of 1 teacher to fourteen (14) students when necessary during the regular or extended school year to provide services to students with disabilities.

In the event a NPS is unable to fill a vacant teaching position responsible for direct instruction to students, and the vacancy has direct impact on the CDE Certification of that school, the NPS shall develop a plan to ensure appropriate coverage of students by first utilizing existing certificated staff. The NPS and the LEA may agree to one 30 school day period per contract year where class size may be increased to ensure coverage by an appropriately credentialed teacher. Such an agreement shall be in writing and signed by both parties. This provision does not apply to a NPA.

CONTRACTOR providing special education instruction for individuals with exceptional needs between the ages of three and five years, inclusive, shall also comply with the appropriate instructional adult to child ratios pursuant to California Education Code sections 56440 et seq.

25. CALENDARS

When CONTRACTOR is a NPS, CONTRACTOR shall submit to the LEA/SELPA a school calendar with the total number of billable days not to exceed 180 days, plus extended school year billable days equivalent to the number of days determined by the LEA's extended school year calendar. Billable days shall include only those days that are included on the submitted and approved school calendar, and/or required by the IEP (developed by the LEA) for each student. CONTRACTOR shall not be allowed to change its school calendar and/or amend the number of billable days without the prior written approval of the LEA. Nothing in this Master Contract shall be interpreted to require the LEA to accept any requests for calendar changes.

Unless otherwise specified by the student's IEP, educational services shall occur at the school site. A student shall only be eligible for extended school year services as determined by the IEP team and the provision of such is specifically included in the ISA. Extended school year shall consist of twenty (20) instructional days, unless otherwise agreed upon by the IEP team convened by the LEA. Any days of extended school year in excess of twenty (20) billable days must be mutually agreed to, in writing, prior to the start of the extended school year.

Student must have actually been in attendance during the regular school year and/or during extended school year and received services on a billable day of attendance in order for CONTRACTOR to be eligible for payment. It is specifically understood that services may not be provided on weekends/holidays and other times when school is not in session, unless agreed to by the LEA, in writing, in advance of the delivery of any NPS service. Any instructional days provided without this written agreement shall be at the sole financial responsibility of the CONTRACTOR.

CONTRACTOR shall observe the same legal holidays as LEA. Those holidays are Labor Day, Veteran's Day, Thanksgiving Day, Christmas Day, New Year's Day, Martin Luther King Jr. Day, President's Day, Memorial Day and Independence Day. With the approval of LEA, CONTRACTOR may revise the date upon which CONTRACTOR closes in observance of any of the holidays observed by the LEA.

When CONTRACTOR is a NPA, CONTRACTOR shall be provided with a LEA-developed/approved calendar prior to the initiation of services. CONTRACTOR herein agrees to observe holidays as specified in the LEA-developed/approved calendar. CONTRACTOR shall provide services pursuant to the

LEA-developed/approved calendar; or as specified in the LEA student's IEP and ISA. Unless otherwise specified in the LEA student's ISA, CONTRACTOR shall provide related services to LEA students on only those days that the LEA student's school of attendance is in session and the LEA student attends school. CONTRACTOR shall bill only for services provided on billable days of attendance as indicated on the LEA calendar unless CONTRACTOR and the LEA agree otherwise, in writing. Student must have actually been in attendance and/or received services on a billable day of attendance in order for CONTRACTOR to be eligible for payment. It is specifically understood that services may not be provided on weekends/holidays and other times when school is not in session, unless agreed to by the LEA, in writing, in advance of the delivery of any NPA service provided by CONTRACTOR. Any instructional days provided without this written agreement shall be at the sole financial responsibility of the CONTRACTOR.

26. DATA REPORTING

CONTRACTOR shall agree to provide to the LEA all data related to student information and billing information with LEA. CONTRACTOR shall agree to provide data related to all sections of this contract, including student discipline as noted below, and requested by and in the format required by the LEA. It is understood that all NPS/A shall utilize the LEA approved electronic IEP system for all IEP development, service tracking documentation, and progress reporting, unless otherwise agreed to by the LEA. Additional progress reporting may be required by the LEA. The LEA shall provide the CONTRACTOR with appropriate software, user training and proper internet permissions to allow adequate access.

Using forms developed by the CDE or as otherwise mutually agreed upon by CONTRACTOR and LEA, CONTRACTOR shall provide LEA, on a monthly basis, a written report of all incidents in which a statutory offense is committed by any LEA student, regardless if it results in a disciplinary action of suspension or expulsion. This includes all statutory offenses as described in Education Code sections 48900 and 48915. CONTRACTOR shall also include incidents resulting in the use of a behavioral restraint and/or seclusion even if they were not a result of a violation of Education Code sections 48900 and 48915.

The LEA shall provide the CONTRACTOR with approved forms and/or format for such data including, but not limited to, invoicing, attendance reports and progress reports. The LEA may approve use of CONTRACTOR'S provided forms at their discretion.

27. LEAST RESTRICTIVE ENVIRONMENT/DUAL ENROLLMENT

CONTRACTOR and LEA shall follow all LEA policies and procedures that support Least Restrictive Environment ("LRE") options and/or dual enrollment options if available and appropriate, for students to have access to the general curriculum and to be educated with their nondisabled peers to the maximum extent appropriate.

CONTRACTOR and LEA shall ensure that LRE placement options are addressed at all IEP team meetings regarding students for whom ISAs have been or may be executed. This shall include IEP team consideration of supplementary aids and services, goals and objectives necessary for placement in the LRE and necessary to enable students to transition to less restrictive settings.

When an IEP team has determined that a student should be transitioned into the public school setting, CONTRACTOR shall assist the LEA in implementing the IEP team's recommended activities to support the transition.

28. STATEWIDE ACHIEVEMENT TESTING

When CONTRACTOR is a NPS, per implementation of Senate Bill 484, CONTRACTOR shall administer all statewide assessments within the California Assessment of Student Performance and Progress ("CAASPP"), Desired Results Developmental Profile ("DRDP"), California Alternative Assessment ("CAA"), achievement and abilities tests (using LEA-authorized assessment instruments), the

Fitness Gram, , the English Language Proficiency Assessments for California (“ELPAC”), the Alternative English Language Proficiency Assessments for California (“Alternative ELPAC”), and as appropriate to the student, and mandated by LEA pursuant to LEA and state and federal guidelines.

CONTRACTOR is subject to the alternative accountability system developed pursuant to Education Code section 52052, in the same manner as public schools. Each LEA student placed with CONTRACTOR by the LEA shall be tested by qualified staff of CONTRACTOR in accordance with that accountability program. LEA shall provide test administration training to CONTRACTOR’S qualified staff. CONTRACTOR shall attend LEA test training and comply with completion of all coding requirements as required by LEA.

29. MANDATED ATTENDANCE AT LEA MEETINGS

CONTRACTOR shall attend District mandated meetings when legal mandates, and/or LEA policy and procedures are reviewed, including but not limited to the areas of: curriculum, high school graduation, standards-based instruction, behavior intervention, cultural and linguistic needs of students with disabilities, dual enrollment responsibilities, LRE responsibilities, transition services, data collection, and standardized testing and IEPs. LEA shall provide CONTRACTOR with reasonable notice of mandated meetings. Attendance at such meetings does not constitute a billable service hour(s).

30. POSITIVE BEHAVIOR INTERVENTIONS AND SUPPORTS

CONTRACTOR shall comply with the requirements of Education Code section 49005, *et seq.*, 56521.1 and 56521.2. LEA students who exhibit behaviors that interfere with their learning or the learning of others must receive timely and appropriate assessments and positive supports and interventions in accordance with the federal law and it’s implementing regulations. If the IEP team determines that a student’s behavior impedes his or her learning or the learning of others, the IEP team is required to consider the use of positive behavioral interventions and supports, and other strategies, to address that behavior, consistent with Section 1414(d)(3)(B)(i) and (d)(4) of Title 20 of the United States Code and associated federal regulations. This could mean that instead of developing a Behavior Intervention Plan (“BIP”), the IEP team may conclude it is sufficient to address the student’s behavioral problems through the development of behavioral goals and behavioral interventions to support those goals.

CONTRACTOR shall maintain a written policy pursuant to California Education Code section 56521.1 regarding emergency interventions and behavioral emergency reports. CONTRACTOR shall ensure that all of its staff members are trained in crisis intervention, emergency procedures, and evidenced-based practices and interventions specific to the unique behavioral needs of the CONTRACTOR’s pupil population. The training shall be provided within 30 days of employment to new staff who have any contact or interaction with pupils during the school day, and annually to all staff who have any contact or interaction with pupils during the school day. The CONTRACTOR shall select and conduct the training in accordance with California Education Code section 56366.1. CONTRACTOR shall maintain written records of the training and provide written verification of the training annually and upon request.

Pursuant to Education Code section 56521.1, emergency interventions shall not be used as a substitute for a BIP, and shall not be employed longer than necessary to contain the behavior. Emergency interventions may only be used to control unpredictable, spontaneous behavior that poses clear and present danger of serious physical harm to the individual with exceptional needs, or others, and that cannot be immediately prevented by a response less restrictive than the temporary application of a technique used to contain the behavior. If a situation requires prolonged use of emergency intervention, staff must seek assistance from the school site administrator or a law enforcement agency.

CONTRACTOR shall complete a behavior emergency report when an emergency occurs that is defined as a serious, dangerous behavior that staff has determined to present a clear and present danger to others. It requires a non-violent physical intervention to protect the safety of student, self, or others and a physical intervention has been used; or a physical intervention has not been used, but an injury or serious property damage has occurred. Personal Safety Techniques may or may not have been used. Emergencies

require a behavior emergency report form be completed and submitted to the LEA within twenty-four (24) hours for administrative action. CONTRACTOR shall notify Parent within twenty-four (24) hours via telephone. If the student's IEP does not contain a BIP, an IEP team shall schedule a meeting to review the behavior emergency report, determine if there is a necessity for a functional behavioral assessment, and to determine an interim plan. If the student already has a BIP, the IEP team shall review and modify the BIP if a new serious behavior has been exhibited or existing behavioral interventions have proven to be ineffective. CONTRACTOR shall schedule with LEA an IEP meeting within two (2) days.

Pursuant to Education Code section 56521.2, CONTRACTOR shall not authorize, order, consent to, or pay for the following interventions, or any other interventions similar to or like the following:

(1) any intervention that is designed to, or likely to, cause physical pain, including, but not limited to, electric-shock; (2) an intervention that involves the release of noxious, toxic, or otherwise unpleasant sprays, mists, or substances in proximity to the face of the individual; (3) an intervention that denies adequate sleep, food, water, shelter, bedding, physical comfort, or access to bathroom facilities; (4) an intervention that is designed to subject, used to subject, or likely to subject, the individual to verbal abuse, ridicule, or humiliation, or that can be expected to cause excessive emotional trauma; (5) restrictive interventions that employ a device, material, or objects that simultaneously immobilize all four extremities, including the procedure known as prone containment, except that prone containment or similar techniques may be used by trained personnel as a limited emergency intervention; (6) locked seclusion, unless it is in a facility otherwise licensed or permitted by state law to use a locked room; (7) an intervention that precludes adequate supervision of the individual; (8) an intervention that deprives the individual of one or more of his or her senses.

In the case of a child whose behavior impedes the child's learning or that of others, the IEP team shall consider the use of positive behavioral interventions and supports, and other strategies, to address that behavior, consistent with Section 1414(d)(3)(B)(i) and (d)(4) of Title 20 of the United States Code and associated federal regulations.

All restraint practices must be reviewed and revised when they have an adverse effect on a student and are used repeatedly for an individual child, either on multiple occasions within the same classroom or multiple uses by the same individual. CONTRACTOR shall notify the student's parent/guardian when any type of physical or mechanical restraint or seclusion has been used. Upon the use of any type of physical or mechanical restraint or seclusions of an LEA student, CONTRACTOR shall complete a BER per the reporting and notification requirements listed above.

31. STUDENT DISCIPLINE

CONTRACTOR shall maintain and abide by a written policy for student discipline that is consistent with state and federal law and regulations. Using forms developed by the California Department of Education or as otherwise mutually agreed upon by CONTRACTOR and LEA, CONTRACTOR shall provide LEA, on a monthly basis, a written report of all incidents in which a statutory offense is committed by any LEA student, regardless if it results in a disciplinary action of suspension or expulsion. This includes all statutory offenses as described in Education Codes 48900 and 48915. CONTRACTOR shall also include incidents resulting in the use of a behavioral restraint and/or seclusion even if they were not a result of a violation of Education Code Sections 48900 and 48915.

When CONTRACTOR seeks to remove a student from his/her current educational placement for disciplinary reasons, CONTRACTOR shall immediately submit a written discipline report to the LEA. Written discipline reports shall include, but not be limited to: the student's name; the time, date, and description of the misconduct; the disciplinary action taken by CONTRACTOR; and the rationale for such disciplinary action. A copy of the student's behavior plan, if any, shall be submitted with the written discipline report. CONTRACTOR and LEA agree to participate in a manifestation determination at an IEP meeting no later than the tenth (10th) day of suspension.

32. IEP TEAM MEETINGS

An IEP team meeting shall be convened at least annually to evaluate: (1) the educational progress of each student placed with CONTRACTOR, including all state assessment results pursuant to the requirements of Education Code section 52052; (2) whether or not the needs of the student continue to be best met at the NPS; and (3) whether changes to the student's IEP are necessary, including whether the student may be transitioned to a public school setting. (California Education Code sections 56366 (a) (2) (B) (i) and (ii)) and pursuant to California Education Code section 56345 (b) (4).)

If the LEA student is to be transferred from a NPS setting into a regular class setting in a public school for any part of the school day, the IEP team shall document, if appropriate, a description of activities provided to integrate the student into the regular education program, including the nature of each activity as well as the time spent on the activity each day or week and a description of the activities provided to support the transition of the student from the special education program into the regular education program. Each student shall be allowed to provide confidential input to any representative of his or her IEP team. Except as otherwise provided in the Master Contract, CONTRACTOR and LEA shall participate in all IEP team meetings regarding students for whom ISAs have been or may be executed. At any time during the term of this Master Contract, the parent, the CONTRACTOR or the LEA may request a review of the student's IEP, subject to all procedural safeguards required by law, including reasonable notice given to, and participation of, the CONTRACTOR in the meeting. Every effort shall be made to schedule IEP team meetings at a time and place that is mutually convenient to parent, CONTRACTOR and LEA. CONTRACTOR shall provide to LEA assessments and written assessment reports by service providers upon request and/or pursuant to LEA policy and procedures. It is understood that attendance at an IEP meeting is part of CONTRACTOR'S professional responsibility and is not a billable service under this Master Contract.

It is understood that the CONTRACTOR shall utilize the approved electronic IEP system of the LEA for all IEP planning and progress reporting at the LEA's discretion. The LEA or SELPA may provide training for any CONTRACTOR to ensure access to the approved system. The CONTRACTOR shall maintain confidentiality of all IEP data on the approved system and shall protect the password requirements of the system. When a student dis-enrolls from the NPS/NPA, the NPS/NPA and LEA shall discontinue use of the approved system for that student.

Changes in any student's educational program, including instruction, services, or instructional setting provided under this Master Contract, may only be made on the basis of revisions to the student's IEP. In the event that the CONTRACTOR believes the student requires a change of placement, the CONTRACTOR may request a review of the student's IEP for the purposes of consideration of a change in the student's placement. Student is entitled to remain in the last agreed upon and implemented placement unless parent agrees otherwise or an Interim Alternative Educational Setting is deemed lawful and appropriate by LEA or OAH consistent with Section 1415 (k)(1)(7) of Title 20 of the United States Code.

33. SURROGATE PARENTS AND FOSTER YOUTH

CONTRACTOR shall comply with LEA surrogate parent assignments. Surrogate parents shall serve as the child's parent and have all the rights relative to the student's education that a parent has under the Individuals with Disabilities Education Act pursuant to *20 USC 1414-1482 and 34 CFR 300.1-300.756*. A pupil in foster care shall be defined pursuant to California Education Code section 42238.01(b). The LEA shall annually notify the CONTRACTOR who the LEA has designated as the educational liaison for foster children. When a pupil in foster care is enrolled in a NPS by the LEA any time after the completion of the pupil's second year of high school, the CONTRACTOR shall schedule the pupil in courses leading towards graduation based on the diploma requirements of the LEA unless provided notice otherwise in writing pursuant to Section 51225.1.

34. DUE PROCESS PROCEEDINGS

CONTRACTOR shall fully participate in special education due process proceedings including mediations and hearings, as requested by LEA. Participation further includes the willingness to make CONTRACTOR's staff available for witness preparation and testimony as is necessary to facilitate a due process hearing. CONTRACTOR shall also fully participate in the investigation and provision of documentation related to any complaint filed with the State of California, the Office of Civil Rights, or any other state and/or federal governmental body or agency. Full participation shall include, but in no way be limited to, cooperating with LEA representatives to provide complete answers raised by any investigator and/or the immediate provision of any and all documentation that pertains to the operation of CONTRACTOR's program and/or the implementation of a particular student's IEP/Individual and Family Service Plan ("IFSP").

35. COMPLAINT PROCEDURES

CONTRACTOR shall maintain and adhere to its own written procedures for responding to parent complaints. These procedures shall include annually notifying and providing parents of students with appropriate information (including complaint forms) for the following: (1) Uniform Complaint Procedures pursuant to Title 5 of the California Code of Regulations section 4600 *et seq.*; (2) Nondiscrimination policy pursuant to Title 5 of the California Code of Regulations section 4960 (a); (3) Sexual Harassment Policy, California Education Code 231.5 (a) (b) (c); (4) Title IX Student Grievance Procedure, Title IX 106.8 (a) (d) and 106.9 (a); and (5) Notice of Privacy Practices in compliance with Health Insurance Portability and Accountability Act ("HIPAA"). CONTRACTOR shall include verification of these procedures to the LEA. CONTRACTOR shall immediately notify LEA of any complaints filed against it related to LEA students and provide LEA with all documentation related to the complaints and/or its investigation of complaints, including any and all reports generated as a result of an investigation.

36. STUDENT PROGRESS REPORTS/REPORT CARDS AND ASSESSMENTS

Unless LEA requests in writing that progress reports be provided on a monthly basis, CONTRACTOR shall provide to parents at least four (4) written progress reports/report cards. At a minimum, progress reports shall include progress over time towards IEP goals and objectives. A copy of the progress reports/report cards shall be maintained at the CONTRACTOR's place of business and shall be submitted to the LEA and LEA student's parent(s) quarterly.

The CONTRACTOR shall also provide an LEA representative access to supporting documentation used to determine progress on any goal or objective, including but not limited to log sheets, observation notes, data sheets, pre/post tests, rubrics and other similar data collection used to determine progress or lack of progress on approved goals, objectives, transition plans or behavior intervention plans. The LEA may request such data at any time within five (5) years of the date of service. The CONTRACTOR shall provide this data supporting progress within five (5) business days of request. Additional time may be granted as needed by the LEA.

CONTRACTOR shall complete academic or other evaluations of the student ten (10) days prior to the student's annual or triennial review IEP team meeting for the purpose of reporting the student's present levels of performance at the IEP team meeting as required by state and federal laws and regulations and pursuant to LEA policies, procedures, and/or practices. CONTRACTOR shall provide sufficient copies of its reports, documents, and projected goals to share with members of the IEP team five (5) business days prior to the IEP meeting. CONTRACTOR shall maintain supporting documentation such as test protocols and data collection, which shall be made available to LEA within five (5) business days of request.

The CONTRACTOR is responsible for all evaluation costs regarding the updating of goals and objectives, progress reporting and development of present levels of performance. All assessments resulting from an assessment plan shall be provided by the LEA unless the LEA specifies in writing a request that CONTRACTOR perform such additional assessment. Any assessment and/or evaluation costs may be added to the ISA and/or approved separately by the LEA at the LEA's sole discretion.

It is understood that all billable hours must be in direct services to pupils as specified in the ISA. For NPA services, supervision provided by a qualified individual as specified in Title 5 Regulation, subsection 3065, shall be determined as appropriate and included in the ISA. Supervision means the direct observation of services, data review, case conferencing and program design consistent with professional standards for each professional's license, certification, or credential.

CONTRACTOR shall not charge the student's parent(s) or LEA for the provision of progress reports, report cards, evaluations conducted in order to obtain present levels of performance, interviews, and/or meetings. It is understood that all billable hours have limits to those specified on the ISA consistent with the IEP. It is understood that copies of data collection notes, forms, charts and other such data are part of the pupil's record and shall be made available to the LEA upon written request.

37. TRANSCRIPTS

When CONTRACTOR is a NPS, CONTRACTOR shall prepare transcripts at the close of each semester, or upon student transfer, for students in grades nine (9) through twelve (12) inclusive, and submit them on LEA approved forms to the student's school of residence for evaluation of progress toward completion of diploma requirements as specified in LEA Procedures. CONTRACTOR shall submit to the LEA names of students and their schools of residence for whom transcripts have been submitted as specified by the LEA.

38. STUDENT CHANGE OF RESIDENCE

Within five (5) school days from the date CONTRACTOR becomes aware of a student's change of residence, CONTRACTOR shall notify LEA, in writing, of the student's change of residence as specified in LEA Procedures. Upon enrollment, CONTRACTOR shall notify parents in writing of their obligation to notify CONTRACTOR of the student's change of residence. CONTRACTOR shall maintain, and provide upon request by LEA, documentation of such notice to parents.

If CONTRACTOR had knowledge or should reasonably have had knowledge of the student's change of residence boundaries and CONTRACTOR fails to follow the procedures specified in this provision, LEA shall not be responsible for the costs of services delivered following the student's change of residence.

39. WITHDRAWAL OF STUDENT FROM PROGRAM

CONTRACTOR shall immediately report electronically and in writing to the LEA within five (5) business days when an LEA student is withdrawn without prior notice from school and/or services, including student's change of residence to a residence outside of LEA service boundaries, and student's discharge against professional advice from a NPS/RTC.

40. PARENT ACCESS

CONTRACTOR shall provide for reasonable parental access to students and all facilities including, but not limited to, the instructional setting, recreational activity areas, meeting rooms and student living quarters. CONTRACTOR shall comply with any known court orders regarding parental visits and access to LEA students.

CONTRACTOR operating programs associated with a NPS/RTC shall cooperate with a parent's reasonable request for LEA student therapeutic visits in their home or at the NPS/RTC. CONTRACTOR shall require that parents obtain prior written authorization for therapeutic visits from the CONTRACTOR and the LEA at least thirty (30) days in advance. CONTRACTOR shall facilitate all parent travel and accommodations and for providing travel information to the parent as appropriate. Payment by LEA for approved travel-related expenses shall be made directly through the LEA consistent with LEA Procedures.

CONTRACTOR providing services in the student's home as specified in the IEP shall ensure that at least one parent of the child, or an adult caregiver with written and signed authorization to make decisions in an emergency, is present. The names of any adult caregiver other than the parent shall be provided to the LEA prior to the start of any home based services, including written and signed authorization in emergency situations. The parent shall inform the LEA of any changes of caregivers and provide written authorization for emergency situation. The adult caregiver cannot also be an employee or volunteer associated with the NPS/NPA service provider.

All problems and/or concerns reported to parents, both verbal and written, shall also be provided, in writing, to the LEA.

41. LICENSED CHILDREN'S INSTITUTION ("LCI") CONTRACTORS AND RESIDENTIAL TREATMENT CENTER ("RTC") CONTRACTORS

If CONTRACTOR is a LCI, CONTRACTOR shall adhere to all legal requirements regarding educational placements for LCI students as stated in Education Code 56366 (a) (2) (C), 56366.9 (c) (1), Health and Safety Code section 1501.1(b), AB 1858 (2004), AB490 (Chapter 862, Statutes of 2003), AB 1261 (2005), AB 1166 Chapter 171 (2015), AB 167 Chapter 224 (2010), AB 216 Chapter 324 (2013), AB 379 Chapter 772 (2015), AB 1012 Chapter 703 (2015), and the procedures set forth in the LEA Procedures. An LCI shall not require that a pupil be placed in its NPS as a condition of being placed in its residential facility.

If CONTRACTOR is a NPS/RTC, CONTRACTOR shall adhere to all legal requirements under the Individuals with Disabilities Education Act (IDEA), 20 U.S.C. section 1412(a)(1)(A) and Education Code section 56000, et seq.; amended and reorganized by the Individuals with Disabilities Education Improvement Act of 2004 (IDEIA), 20 U.S.C. section 1401(29); Education Code section 56031; Cal. Code Regs., Title 5, section 3001 et seq., regarding the provision of counseling services, including residential care for students to receive a FAPE as set forth in the LEA student's IEPs. CONTRACTOR shall meet all monitoring requirements as noted in Section 43 below.

If CONTRACTOR is a NPS that is owned, operated by, or associated with a LCI, CONTRACTOR shall provide to LEA, on a quarterly basis, a list of all students, including those identified as eligible for special education. For those identified as special education students, the list shall include: 1) special education eligibility at the time of enrollment and; 2) the educational placement and services specified in each student's IEP at the time of enrollment. A copy of the current IEP shall be provided to the LEA.

Unless placement is made pursuant to an Office of Administrative Hearings order or a lawfully executed agreement between LEA and parent, LEA is not responsible for the costs associated with NPS placement until the date on which an IEP team meeting is convened, the IEP team determines that a NPS placement is appropriate, and the IEP is signed by the student's parent or another adult with educational decision-making rights.

In addition to meeting the certification requirements of the State of California, a CONTRACTOR that operates a program outside of this State shall be certified or licensed by that state to provide, respectively, special education and related services and designated instruction and related services to pupils under the federal Individuals with Disabilities Education Act (20 U.S.C. Sec. 1400 et seq.).

42. STATE MEAL MANDATE

When CONTRACTOR is a NPS, CONTRACTOR and LEA shall satisfy the State Meal Mandate under California Education Code sections 49530, 49530.5 and 49550.

43. MONITORING

When CONTRACTOR is a NPS, the LEA (or SELPA) shall conduct at least one onsite monitoring visit during each school year to the NPS at which the LEA has a pupil attending and with which it maintains a

master contract. The monitoring visit shall include, but is not limited to, a review of services provided to the pupil through the ISA between the LEA and the NPS, a review of progress the pupil is making toward the goals set forth in the pupil's individualized education program, a review of progress the pupil is making toward the goals set forth in the pupil's behavioral intervention plan, if applicable, an observation of the pupil during instruction, and a walkthrough of the facility. The LEA (or SELPA) shall report the findings resulting from the monitoring visit to the California Department of Education within 60 calendar days of the onsite visit.

The LEA (or SELPA) shall conduct an onsite visit to the NPS before placement of a pupil if the LEA does not have any pupils enrolled at the school at the time of placement.

CONTRACTOR shall allow LEA representatives access to its facilities for additional periodic monitoring of each student's instructional program. LEA shall have access to observe each student at work, observe the instructional setting, interview CONTRACTOR, and review each student's records and progress. Such access shall include unannounced monitoring visits. When making site visits, LEA shall initially report to CONTRACTOR's site administrative office. CONTRACTOR shall be invited to participate in the review of each student's progress.

If CONTRACTOR is also an LCI and/or NPS/RTC, the CDE shall annually evaluate whether CONTRACTOR is in compliance with Education Code section 56366.9 and Health and Safety Code section 1501.1(b).

The State Superintendent of Public Instruction ("Superintendent") shall monitor CONTRACTOR'S facilities, the educational environment, and the quality of the educational program, including the teaching staff, the credentials authorizing service, the standards-based core curriculum being employed, and the standard focused instructional materials used on a three-year cycle, as follows: (1) CONTRACTOR shall complete a self-review in year one; (2) the Superintendent shall conduct an onsite review in year two; and (3) the Superintendent shall conduct a follow-up visit in year three.

CONTRACTOR shall participate in any LEA or CDE compliance review, if applicable, to be conducted as aligned with the CDE Onsite Review and monitoring cycle in accordance with California Education Code section 56366.1(j). This review will address programmatic aspects of the NPS, compliance with relevant state and federal regulations, and Master Contract compliance. CONTRACTOR shall conduct any follow-up or corrective action procedures related to review findings.

CONTRACTOR understands that LEA reserves the right to institute a program audit with or without cause. The program audit may include, but is not limited to, a review of core compliance areas of health and safety; curriculum/instruction; related services; and contractual, legal, and procedural compliance.

When CONTRACTOR is a NPS, CONTRACTOR shall collect all applicable data and prepare the applicable portion of a School Accountability Report Card as appropriate in accordance with California Education Code Section 33126.

PERSONNEL

44. CLEARANCE REQUIREMENTS

CONTRACTOR shall comply with the requirements of California Education Code sections 44237, 35021.1, 35021.2, and 56366.1 including, but not limited to: obtaining clearance from both the California Department of Justice (hereinafter referred to as "CDOJ") and clearance from the Federal Bureau of Investigation (hereinafter referred to as "FBI") for CONTRACTOR'S employees and volunteers who will have or likely may have any direct contact with LEA students. CONTRACTOR hereby agrees that CONTRACTOR'S employees and volunteers shall not come in contact with students until CDOJ and FBI clearance are ascertained. CONTRACTOR shall certify in writing to LEA that none of its employees, and volunteers, unless CONTRACTOR determines that the volunteers will have no direct contact with students, or subcontractors who may come into contact with students have been convicted of a violent or

serious felony as those terms are defined in California Education Code section 44237(h), unless despite the employee's conviction of a violent or serious felony, he or she has met the criteria to be eligible for employment pursuant to California Education Code section 44237 (i) or (j). Contractor shall certify to LEA that they have successful background checks and enrolled in subsequent arrest notification service for all employees who may come into contact with students.

Notwithstanding the restrictions on sharing and destroying criminal background check information, CONTRACTOR, upon demand, shall make available to the LEA evidence of a successful criminal background check clearance and enrollment in subsequent arrest notification service, as provided, for each owner, operator, and employee of the NPS/A. CONTRACTOR is required to retain the evidence on-site, as specified, for all staff, including those licensed or credentialed by another state agency. Background clearances and proof of subsequent arrest notification service, as required by California Penal Code section 11105.2, for all staff shall be provided to the LEA upon request.

45. STAFF QUALIFICATIONS

CONTRACTOR shall ensure that all individuals employed, contracted, and/or otherwise hired by CONTRACTOR to provide classroom and/or individualized instruction or related services hold a license, certificate, permit, or other document equivalent to that which staff in a public school are required to hold in the service rendered consistent with Education Code section 56366.1(n)(1) and are qualified pursuant to Title 34 of the Code of Federal Regulations sections 200.56 and 200.58, and Title 5 of the California Code of Regulations sections 3001(r), 3064 and 3065. Such qualified staff may only provide related services within the scope of their professional license, certification or credential and ethical standards set by each profession, and not assume responsibility or authority for another related services provider or special education teacher's scope of practice.

CONTRACTOR shall ensure that all staff are appropriately credentialed to provide instruction and services to students with the disabling conditions placed in their program/school through documentation provided to the CDE (5 CCR 3064 (a)).

When CONTRACTOR is a NPS, an appropriately qualified person shall serve as curricular and instructional leader, and be able to provide leadership, oversight and professional development. The administrator of the NPS holds or is in the process of obtaining one of the following: (A) An administrative credential granted by an accredited postsecondary educational institution and two years of experience with pupils with disabilities. (B) A pupil personnel services credential that authorizes school counseling or psychology. (C) A license as a clinical social worker issued by the Board of Behavioral Sciences. (D) A license in psychology regulated by the Board of Psychology. (E) A master's degree issued by an accredited postsecondary institution in education, special education, psychology, counseling, behavioral analysis, social work, behavioral science, or rehabilitation. (F) A credential authorizing special education instruction and at least two years of experience teaching in special education before becoming an administrator. (G) A license as a marriage and family therapist certified by the Board of Behavioral Sciences. (H) A license as an educational psychologist issued by the Board of Behavioral Sciences. (I) A license as a professional clinical counselor issued by the Board of Behavioral Sciences. (California Education Code Section 56366.1 (a)(5))

CONTRACTOR shall comply with personnel standards and qualifications regarding instructional aides and teacher assistants respectively pursuant to federal requirements and California Education Code sections 45340 *et seq.* and 45350 *et seq.* Specifically, all paraprofessionals, including but not limited to, instructional aides and teacher assistants, employed, contracted, and/or otherwise hired or subcontracted by CONTRACTOR to provide classroom and/or individualized instruction or related services, shall possess a high school diploma (or its recognized equivalent) and at least one of the following qualifications: (a) completed at least two (2) years of study at an institution of higher education; or (b) obtained an associate's (or higher) degree; or (c) met a rigorous standard of quality and can demonstrate, through a formal state or local assessment (i) knowledge of, and the ability to assist in instructing, reading, writing, and mathematics; or (ii) knowledge of, and the ability to assist in instructing, reading readiness, writing readiness, and mathematics readiness, as appropriate. CONTRACTOR shall comply

with all laws and regulations governing the licensed professions, including but not limited to, the provisions with respect to supervision.

In addition to meeting the certification requirements of the State of California, a CONTRACTOR that operates a program outside of this state and serving a student by this LEA shall be certified or licensed by that state to provide special education and related services to pupils under the federal Individuals with Disabilities Education Act (20 U.S.C. Sec. 1400 et seq.).

46. VERIFICATION OF LICENSES, CREDENTIALS AND OTHER DOCUMENTS

CONTRACTOR shall submit to LEA a staff list, and copies of all current licenses, credentials, certifications, permits and/or other documents which entitle the holder to provide special education and/or related services by individuals employed, contracted, and/or otherwise hired or sub-contracted by CONTRACTOR. CONTRACTOR shall ensure that all licenses, credentials, permits or other documents are on file at the office of the County Superintendent of Schools. CONTRACTOR shall provide the LEA with the verified dates of fingerprint clearance, Department of Justice clearance and Tuberculosis Test clearance for all employees, approved subcontractors and/or volunteers prior to such individuals starting to work with any student.

CONTRACTOR shall monitor the status of licenses, credentials, certifications, permits and/or other documents for all individuals employed, contracted, and/or otherwise hired by CONTRACTOR. CONTRACTOR shall notify LEA and CDE in writing within forty-five (45) days when personnel changes occur which may affect the provision of special education and/or related services to LEA students. CONTRACTOR shall notify LEA within forty-five (45) days if any such licenses, certifications or waivers are expired, suspended, revoked, rescinded, challenged pursuant to an administrative or legal complaint or lawsuit, or otherwise nullified during the effective period of this Master Contract. The LEA shall not be obligated to pay for any services provided by a person whose such licenses, certifications or waivers are expired, suspended, revoked, rescinded, or otherwise nullified during the period which such person is providing services under this Master Contract. Failure to notify the LEA and CDE of any changes in credentialing/licensed staff may result in suspension or revocation of CDE certification and/or suspension or termination of this Master Contract by the LEA.

47. STAFF ABSENCE

When CONTRACTOR is a NPA and/or related services provider, and CONTRACTOR's service provider is absent, CONTRACTOR shall provide a qualified (as defined in Section 7 of this agreement and as determined by LEA) substitute, unless LEA provides appropriate coverage in lieu of CONTRACTOR's service providers. It is understood that the parent of a student shall not be deemed to be a qualified substitute for their student. LEA will not pay for services unless a qualified substitute is provided and/or CONTRACTOR provides documentation evidencing the provision of "make-up" services by a qualified service provider within thirty (30) calendar days from the date on which the services should have been provided. CONTRACTOR shall not "bank" or "carry over" make up service hours under any circumstances, unless otherwise agreed to in writing by CONTRACTOR and authorized LEA representative.

48. STAFF PROFESSIONAL BEHAVIOR WHEN PROVIDING SERVICES AT SCHOOL OR SCHOOL RELATED EVENTS OR AT SCHOOL FACILITY AND/OR IN THE HOME

It is understood that all employees, subcontractors, and volunteers of any certified NPS/A shall adhere to the customary professional and ethical standards when providing services. All practices shall only be within the scope of professional responsibility as defined in the professional code of conduct for each profession as well as any LEA professional standards as specified in Board policies and/or regulations when made available to the CONTRACTOR.

For services provided on a public school campus, sign in/out procedures shall be followed by NPS/A providers working in a public school classroom along with all other procedures for being on campus

consistent with school and district policy. Such policies and procedures shall be made available to the CONTRACTOR upon request. It is understood that the public school credentialed classroom teacher is responsible for the instructional program.

CONTRACTOR providing services outside of the student's school as specified in the IEP shall ensure that at least one parent of the child or an adult caregiver with written and signed authority to make decisions in an emergency is present during provision of services. The names of any adult caregiver other than the parent shall be provided to the LEA prior to the start of any home-based services, including written and signed authorization in emergency situations. The adult caregiver cannot also be an employee or volunteer associated with the NPS/NPA service provider. All problems and/or concerns reported by CONTRACTOR to parents or guardians, in either verbal or written form, shall be reported to the LEA.

HEALTH AND SAFETY MANDATES

49. HEALTH AND SAFETY

CONTRACTOR shall comply with all applicable federal, state, local, and LEA laws, regulations, ordinances, policies, and procedures regarding student and employee health and safety. CONTRACTOR shall comply with the requirements of California Education Code sections 35021 *et. seq.* and 49406, regarding the examination of CONTRACTOR's employees and volunteers for tuberculosis. CONTRACTOR shall provide to LEA documentation for each individual volunteering, employed, contracted, and/or otherwise hired by CONTRACTOR of such compliance before an individual comes in contact with a student.

CONTRACTOR shall comply with OSHA Blood-Borne Pathogens Standards, 29 Code of Federal Regulations (CFR) section 1910.1030, when providing medical treatment or assistance to a student. CONTRACTOR further agrees to provide annual training regarding universal health care precautions and to post required notices in areas designated in the California Health and Safety Code.

50. FACILITIES AND FACILITIES MODIFICATIONS

CONTRACTOR shall provide special education and/or related services to students in facilities that comply with all applicable federal, state, and local laws, regulations, and ordinances related, but not limited to: disability access; fire, health, sanitation, and building standards and safety; fire warning systems; zoning permits; and occupancy capacity. When CONTRACTOR is a NPS, CONTRACTOR shall conduct fire drills as required by Title 5 California Code of Regulations section 550. CONTRACTOR shall be responsible for any structural changes and/or modifications to CONTRACTOR's facilities as required complying with applicable federal, state, and local laws, regulations, and ordinances. Failure to notify the LEA and CDE of any changes in, major modification or relocation of facilities may result in the suspension or revocation of CDE certification and/or suspension or termination of this Master Contract by the LEA.

51. ADMINISTRATION OF MEDICATION

CONTRACTOR shall comply with the requirements of California Education Code section 49423 when CONTRACTOR serves a student that is required to take prescription and/or over-the-counter medication during the school day. CONTRACTOR may designate personnel to assist the student with the administration of such medication after the student's parent(s) provide to CONTRACTOR: (a) a written statement from a physician detailing the type, administration method, amount, and time schedules by which such medication shall be taken; and (b) a written statement from the student's parent(s) granting CONTRACTOR permission to administer medication(s) as specified in the physician's statement. CONTRACTOR shall maintain, and provide to LEA upon request, copies of such written statements. CONTRACTOR shall maintain a written log for each student to whom medication is administered. Such written log shall specify the student's name; the type of medication; the date, time, and amount of each administration; and the name of CONTRACTOR's employee who administered the medication.

CONTRACTOR maintains full responsibility for ensuring appropriate staff training in the administration of such medication consistent with physician's written orders. Any change in medication type, administration method, amount or schedule must be authorized by both a licensed physician and parent.

52. INCIDENT/ACCIDENT REPORTING

CONTRACTOR shall submit within 24 hours, electronically, any accident or incident report to the LEA. CONTRACTOR shall properly submit required accident or incident reports pursuant to the procedures specified in LEA Procedures.

53. CHILD ABUSE REPORTING

CONTRACTOR hereby agrees to annually train all staff members, including volunteers, so that they are familiar with and agree to adhere to its own child and dependent adult abuse reporting obligations and procedures as specified in California Penal Code section 11164 et seq. and Education Code 44691. To protect the privacy rights of all parties involved (i.e., reporter, child and alleged abuser), reports will remain confidential as required by law and professional ethical mandates. A written statement acknowledging the legal requirements of such reporting and verification of staff adherence to such reporting shall be submitted to the LEA.

54. SEXUAL HARASSMENT

CONTRACTOR shall have a Sexual and Gender Identity harassment policy that clearly describes the kinds of conduct that constitutes sexual harassment and that is prohibited by the CONTRACTOR's policy, as well as federal and state law. The policy should include procedures to make complaints without fear of retaliation, and for prompt and objective investigations of all sexual harassment complaints. CONTRACTOR further agrees to provide annual training to all employees regarding the laws concerning sexual harassment and related procedures pursuant to Government Code 12950.1.

55. REPORTING OF MISSING CHILDREN

CONTRACTOR assures LEA that all staff members, including volunteers, are familiar with and agree to adhere to requirements for reporting missing children as specified in California Education Code section 49370. A written statement acknowledging the legal requirements of such reporting and verification of staff adherence to such reporting shall be properly submitted to the LEA. The written statement shall be submitted as specified by the LEA.

FINANCIAL

56. ENROLLMENT, CONTRACTING, SERVICE TRACKING, ATTENDANCE REPORTING, AND BILLING PROCEDURES

CONTRACTOR shall assure that the nonpublic school or nonpublic agency has the necessary financial resources to provide an appropriate education for the students enrolled and will distribute those resources in such a manner to implement the IEP and ISA for each and every student.

CONTRACTOR shall comply with all LEA procedures concerning enrollment, contracting, attendance reporting, service tracking and billing including requirements of electronic billing as specified by the LEA Procedures, as well as provide all such records requested by LEA concerning the same. CONTRACTOR shall be paid for the provision of special education and/or related services specified in the student's IEP and ISA. All payments by LEA shall be made in accordance with the terms and conditions of this Master Contract and governed by all applicable federal and state laws.

CONTRACTOR shall maintain separate registers for the basic education program, each related service, and services provided by instructional assistants, behavior intervention aides and bus aides. Original attendance forms (i.e., roll books for the basic education program, service tracking documents and notes

for instructional assistants, behavioral intervention aides, bus aides, and each related service) shall be completed by the actual service provider whose signature shall appear on such forms and shall be available for review, inspection, or audit by LEA during the effective period of this contract and for a period of five (5) years thereafter. CONTRACTOR shall verify the accuracy of minutes of reported attendance that is the basis of services being billed for payment.

CONTRACTOR shall submit invoices and related documents to LEA for payment, for each calendar month when education or related services were provided. Invoices and related documents shall be properly submitted electronically and in addition, on an LEA form with signatures in the manner prescribed by LEA. At a minimum, each invoice must contain the following information: month of service; specific days and times of services coordinated by the LEA approved calendar unless otherwise specified in the IEP or agreed to by the LEA; name of staff who provided the service; approved cost of each invoice; total for each service and total for the monthly invoice; date invoice was mailed; signature of NPS/NPA administrator authorizing that the information is accurate and consistent with the ISA, CDE certificates and staff notification; verification that attendance report is attached as appropriate; indication of any made-up session consistent with this contract; verification that progress reports have been provided consistent with the ISA (monthly or quarterly unless specified otherwise on the ISA); and name or initials of each student for when the service was provided.

In the event services were not provided, rationale for why the services were not provided shall be included.

Such an invoice is subject to all conditions of this contract. At the discretion of the LEA, an electronic invoice may be required provided such notice has been made in writing and training provided to the CONTRACTOR at no additional charge for such training.

Invoices shall be submitted no later than thirty (30) days after the end of the attendance accounting period in which the services were rendered. LEA shall make payment to CONTRACTOR based on the number of billable days of attendance and hours of service at rates specified in this contract within forty-five (45) days of LEA's receipt of properly submitted hard copy of invoices prepared and submitted as specified in California Education Code Section 56366.5 and the LEA. CONTRACTOR shall correct deficiencies and submit rebilling invoices no later than thirty (30) calendar days after the invoice is returned by LEA. LEA shall pay properly submitted re-billing invoices no later than forty-five (45) days after the date a completely corrected re-billing invoice is received by LEA.

In no case shall initial payment claim submission for any Master Contract fiscal year (July through June) extend beyond December 31st after the close of the fiscal year. In no case shall any rebilling for the Master Contract fiscal year (July through June) extend beyond six (6) months after the close of the fiscal year unless approved by the LEA to resolve billing issues including re-billing issues directly related to a delay in obtaining information from the Commission on Teacher Credentialing regarding teacher qualification, but no later than twelve (12) months from the close of the fiscal year. If the billing or re-billing error is the responsibility of the LEA, then no limit is set provided that the LEA and CONTRACTOR have communicated such concerns in writing during the 12-month period following the close of the fiscal year. LEA will not pay mileage for NPA employee.

57. RIGHT TO WITHHOLD PAYMENT

LEA may withhold payment to CONTRACTOR when: (a) CONTRACTOR has failed to perform, in whole or in part, under the terms of this contract; (b) CONTRACTOR has billed for services rendered on days other than billable days of attendance or for days when student was not in attendance and/or did not receive services; (c) CONTRACTOR was overpaid by LEA as determined by inspection, review, and/or audit of its program, work, and/or records; (d) CONTRACTOR has failed to provide supporting documentation with an invoice, as required by EC 56366(c)(2); (e) education and/or related services are provided to students by personnel who are not appropriately credentialed, licensed, or otherwise qualified; (f) LEA has not received prior to school closure or contract termination, all documents concerning one or more students enrolled in CONTRACTOR's educational program; (g) CONTRACTOR fails to confirm

a student's change of residence to another district or confirms the change of residence to another district, but fails to notify LEA within five (5) days of such confirmation; or (h) CONTRACTOR receives payment from Medi-Cal or from any other agency or funding source for a service provided to a student. It is understood that no payments shall be made for any invoices that are not received by six (6) months following the close of the prior fiscal year, for services provided in that year.

Final payment to CONTRACTOR in connection with the cessation of operations and/or termination of a Master Contract will be subject to the same documentation standards described for all payment claims for regular ongoing operations. In addition, final payment may be withheld by the LEA until completion of a review or audit, if deemed necessary by the LEA. Such review or audit will be completed within ninety (90) days. The final payment may be adjusted to offset any previous payments to the CONTRACTOR determined to have been paid in error or in anticipation of correction of documentation deficiencies by the CONTRACTOR that remain uncorrected.

The amount which may be withheld by LEA with respect to each of the subparagraphs of the preceding paragraph are as follows: (a) the value of the service CONTRACTOR failed to perform; (b) the amount of overpayment; (c) the portion of the invoice for which satisfactory documentation has not been provided by CONTRACTOR; (d) the amount invoiced for services provided by the individual not appropriately credentialed, licensed, or otherwise qualified; (e) the proportionate amount of the invoice related to the applicable pupil for the time period from the date the violation occurred and until the violation is cured; or (f) the amount paid to CONTRACTOR by Medi-Cal or another agency or funding source for the service provided to the student.

If LEA determines that cause exists to withhold payment to CONTRACTOR, LEA shall, within ten (10) business days of this determination, provide to CONTRACTOR written notice that LEA is withholding payment. Such notice shall specify the basis or bases for LEA's withholding payment and the amount to be withheld. Within thirty (30) days from the date of receipt of such notice, CONTRACTOR shall take all necessary and appropriate action to correct the deficiencies that form the basis for LEA's withholding payment or submit a written request for extension of time to correct the deficiencies or submit to LEA written documentation demonstrating that the basis or bases cited by the LEA for withholding payment is unfounded. Upon receipt of CONTRACTOR's written request showing good cause, LEA shall extend CONTRACTOR's time to correct deficiencies (usually an additional thirty (30) days), otherwise payment will be denied.

If after subsequent request for payment has been denied and CONTRACTOR believes that payment should not be withheld, CONTRACTOR shall send written notice to LEA specifying the reason it believes payment should not be withheld. LEA shall respond to CONTRACTOR's notice within thirty (30) business days by indicating that a warrant for the amount of payment will be made or stating the reason LEA believes payment should not be made. If LEA fails to respond within thirty (30) business days or a dispute regarding the withholding of payment continues after the LEA's response to CONTRACTOR's notice, CONTRACTOR may invoke the following escalation policy.

After forty-five (45) business days: The CONTRACTOR may notify the Authorized LEA's Representative of the dispute in writing. The LEA Authorized Representative shall respond to the CONTRACTOR in writing within fifteen (15) business days.

After sixty (60) business days: The LEA or CONTRACTOR may appeal to the County Superintendent of Schools so long as the County Superintendent of Schools is not participating in the Local Plan involved in the NPS/A contract, or a mutually agreed upon mediator. Both parties agree to pay for their own costs and expenses arising out of such mediation. Each party agrees to act in good faith in participating in any mediation process agreed to by the parties.

58. PAYMENT FROM OUTSIDE AGENCIES

CONTRACTOR shall notify LEA when Medi-Cal or any other agency is billed for the costs associated with the provision of special education and/or related services to students. Upon request, CONTRACTOR

shall provide to LEA any and all documentation regarding reports, billing, and/or payment by Medi-Cal or any other agency for the costs associated with the provision of special education and/or related services to students. CONTRACTOR shall provide prior written notice of the rights and protections required by Title 34 of the Code of Federal Regulations section 300.154(d) whenever it seeks to use the LEA students' public benefits to pay for special education and related services. Such notice shall be provided before seeking payment from Medi-Cal for the first time and annually.

59. PAYMENT FOR ABSENCES

NONPUBLIC SCHOOL STAFF ABSENCE

Whenever a classroom teacher employed by CONTRACTOR is absent, CONTRACTOR shall provide an appropriately credentialed substitute teacher in the absent teacher's classroom in accordance with California Education Code section 56061. CONTRACTOR shall provide to LEA documentation of substitute coverage pursuant to the LEA Procedures. Substitute teachers shall remain with their assigned class during all instructional time. LEA will not pay for instruction and/or services unless said instruction or service is provided by an appropriately credentialed substitute teacher.

Whenever a related service provider is absent, CONTRACTOR shall provide a qualified (as defined in Section 7 of this agreement and as determined by LEA) substitute. LEA will not pay for services unless a qualified substitute is provided and/or CONTRACTOR provides documentation evidencing the provision of "make-up" services by a qualified service provider within thirty (30) calendar days from the date on which the services should have been provided unless otherwise agreed in student's IEP.

NONPUBLIC SCHOOL STUDENT ABSENCE

If CONTRACTOR is a nonpublic school, no later than the tenth (10th) cumulative day of a student's unexcused absence, CONTRACTOR shall notify the LEA of such absence.

Criteria for a billable day for payment purposes is one (1) day of attendance as defined in California Education Code, sections 46010, 46010.3 and 46307. LEA shall not pay for services provided on days that a student's attendance does not qualify for Average Daily Attendance (ADA) reimbursement under state law. *Per Diem* rates for students whose IEPs authorize less than a full instructional day may be adjusted on a pro rata basis in accordance with the actual proportion of the school day the student was served. LEA shall not be responsible for payment of related services for days on which a student's attendance does not qualify for Average Daily Attendance ("ADA") reimbursement under state law, nor shall student be eligible for make-up services.

NONPUBLIC AGENCY STAFF ABSENCE

When CONTRACTOR is a nonpublic agency and CONTRACTOR's service provider is absent, CONTRACTOR shall provide a qualified (as defined in Section 7 of this agreement and as determined by LEA) substitute, unless LEA provides appropriate coverage in lieu of CONTRACTOR's service providers. LEA shall not pay for services unless a qualified substitute is provided and/or CONTRACTOR provides documentation evidencing the provision of "make-up" services by a qualified service provider within thirty (30) calendar days from the date on which the services should have been provided. CONTRACTOR shall not "bank" or "carry over" make up service hours under any circumstances, unless otherwise agreed to in writing by CONTRACTOR and LEA. In the event services were not provided, reasons for why the services were not provided shall be included.

NONPUBLIC AGENCY STUDENT ABSENCE

If CONTRACTOR is a nonpublic agency, it shall notify LEA of the absence of a student no later than the fifth (5th) consecutive service day of the student's absence. LEA shall not be responsible for the payment of services when a student is absent.

60. LEA and/or NONPUBLIC SCHOOL CLOSURE DUE TO EMERGENCY

The following shall apply in the event of a LEA or NPS school closure due to an emergency consistent with guidelines followed by LEAs in accordance with Education Code sections 41422 and 46392:

- a. If CONTRACTOR remains open, if allowed, during an emergency and serves students appropriately as delineated in the ISA, CONTRACTOR shall receive payment, regardless of whether a sending LEA is open or closed.
- b. NPS School Closure- In the event of a NPS School Closure for the reasons set forth in Education Code section 41422, if the LEA is able to obtain alternative placement for the student, CONTRACTOR shall not receive payment for days the student is not in attendance due to CONTRACTOR'S school closure. If the LEA is unable to obtain an alternative placement, CONTRACTOR shall receive payment consistent with the student's approved ISA, as though the student were continuing his/her regular attendance, until an alternative placement can be found and implement LEA student IEP in accordance with Education Code section 56345(a)(9) pertaining to emergency conditions.
- c. LEA and NPS School Closure- In the event of the LEA and NPS School Closures, on days the LEA is funded, CONTRACTOR shall receive payment consistent with the student's approved ISA, until an alternative placement can be found and implement LEA student IEP in accordance with Education Code section 56345(a)(9) pertaining to emergency conditions. If the LEA is able to obtain alternative placement for the student, CONTRACTOR shall not receive payment for days the student is not in attendance with CONTRACTOR due to CONTRACTOR'S school closure.

When the emergency school closure is lifted, CONTRACTOR shall notify the LEAs it serves of any lost instructional minutes. CONTRACTOR and LEAs shall work collaboratively to determine the need for make-up days or service changes, and shall work together to amend IEP and ISA paperwork as appropriate.

61. INSPECTION AND AUDIT

The CONTRACTOR shall maintain and the LEA shall have the right to examine and audit all of the books, records, documents, accounting procedures and practices and other evidence that reflect all costs claimed to have been incurred or fees claimed to have been earned under this Agreement.

CONTRACTOR shall provide access to LEA to all records including, but not limited to: student records as defined by California Education Code section 49061(b); registers and roll books of teachers; daily service logs and notes or other documents used to record the provision of related services; Medi-Cal/daily service logs and notes used to record provision of services provided by instructional assistants, behavior intervention aides, bus aides, and supervisors; absence verification records (parent/doctor notes, telephone logs, and related documents); bus rosters; staff lists specifying credentials held, business licenses held, documents evidencing other qualifications, , dates of hire, and dates of termination; staff time sheets; non-paid staff and volunteer sign-in sheets; transportation and other related service subcontracts; school calendars; bell/class schedules when applicable; liability and worker's compensation insurance policies; state NPS/A certifications; by-laws; lists of current board of directors/trustees, if incorporated; other documents evidencing financial expenditures; federal/state payroll quarterly reports Form 941/DE3DP; and bank statements and canceled checks or facsimile thereof. Such access shall include unannounced inspections by LEA. CONTRACTOR shall make available to LEA all budgetary information including operating budgets submitted by CONTRACTOR to LEA for the relevant contract period being audited.

CONTRACTOR shall make all records available at the office of LEA or CONTRACTOR's offices (to be specified by LEA) at all reasonable times and without charge. All records shall be provided to LEA within five (5) working days of a written request from LEA. CONTRACTOR shall, at no cost to LEA, provide assistance for such examination or audit. LEA's rights under this section shall also include access to CONTRACTOR's offices for purposes of interviewing CONTRACTOR's employees. If any document or evidence is stored in an electronic form, a hard copy shall be made available to the LEA, unless the LEA agrees to the use of the electronic format.

CONTRACTOR shall obtain from its subcontractors and suppliers written agreements to the requirements of this section and shall provide a copy of such agreements to LEA upon request by LEA.

If an inspection, review, or audit by LEA, a state agency, a federal agency, and/or an independent agency/firm determines that CONTRACTOR owes LEA monies as a result of CONTRACTOR's over billing or failure to perform, in whole or in part, any of its obligations under this Master Contract, LEA shall provide to CONTRACTOR written notice demanding payment from CONTRACTOR and specifying the basis or bases for such demand. Unless CONTRACTOR and LEA otherwise agree in writing, CONTRACTOR shall pay to LEA the full amount owed as a result of CONTRACTOR's over billing and/or failure to perform, in whole or in part, any of its obligations under this Master Contract, as determined by an inspection, review, or audit by LEA, a state agency, a federal agency, and/or an independent agency/firm. CONTRACTOR shall make such payment to LEA within thirty (30) days of receipt of LEA's written notice demanding payment.

62. RATE SCHEDULE

The attached rate schedule (Exhibit A) limits the number of students that may be enrolled and maximum dollar amount of the contract. It may also limit the maximum number of students that can be provided specific services. Per Diem rates for students whose IEPs authorize less than a full instructional day may be adjusted proportionally. In such cases only, the adjustments in basic education rate shall be based on the required minimum number of minutes per grade level as noted in California Education Code Section 46200-46208.

Special education and/or related services offered by CONTRACTOR shall be provided by qualified personnel as per State and Federal law, and the codes and charges for such educational and/or related services during the term of this contract, shall be as stated in Exhibit A.

63. DEBARMENT CERTIFICATION

By signing this agreement, the CONTRACTOR certifies that:

- (a) The CONTRACTOR and any of its shareholders, partners, or executive officers are not presently debarred, suspended, proposed for debarment, or declared ineligible for the award of contracts by any Federal agency, and
- (b) Have not, within a three-year period preceding this contract, been convicted of or had a civil judgment rendered against them for: commission of fraud or a criminal offense in connection with obtaining, attempting to obtain, or performing a Federal, state or local government contract or subcontract; violation of Federal or state antitrust statutes relating to the submission of offers; or commission of embezzlement, theft, forgery, bribery, falsification or destruction of records, making false statements, tax evasion, or receiving stolen property; and are not presently indicted for, or otherwise criminally or civilly charged by a Government entity with, commission of any of these offenses.

The parties hereto have executed this Contract by and through their duly authorized agents or representatives. This contract is effective on the 1st day of July, 2022 and terminates at 5:00 P.M. on June 30, 2023, unless sooner terminated as provided herein.

CONTRACTOR

LEA

The Bay School

 Nonpublic School/Agency

NORTH SANTA CRUZ COUNTY SELPA

 LEA Name

By: *[Signature]* 07 / 25 / 2022

 Signature Date

By: *Jessica Little* 07 / 25 / 2022

 Signature Date

CFO and Treasurer

 Name and Title of Authorized Representative

JESSICA LITTLE, SR. SELPA DIRECTOR

 Name and Title of Authorized Representative

Notices to CONTRACTOR shall be addressed to: Michael Tobin, CFO	Notices to LEA shall be addressed to: JESSICA LITTLE, SR. SELPA DIRECTOR
Name and Title The Bay School	Name and Title NORTH SANTA CRUZ COUNTY SELPA
Nonpublic School/Agency/Related Service Provider 41 Pacella Park	LEA 400 ENCINAL STREET
Address Randolph MA 02368	Address SANTA CRUZ CA 95060
City State Zip 781-440-0400 781-440-0400	City State Zip 831-466-5700 831-466-5964
Phone Fax mtobin@mayinstitute.org	Phone Fax jlittle@santacruzcoe.org
Email	Email
	Additional LEA Notification (Required if completed)
	Name and Title
	Address
	City State Zip
	Phone Fax
	Email

EXHIBIT A: 2022-2023 RATES

4.1 RATE SCHEDULE FOR CONTRACT YEAR

The CONTRACTOR: THE BAY SCHOOL

The CONTRACTOR CDS NUMBER: _____

PER ED CODE 56366 – TEACHER-TO-PUPIL RATIO: _____

Maximum Contract Amount: _____

Education service(s) offered by the CONTRACTOR and the charges for such service(s) during the term of this contract shall be as follows:

- 1) Daily Basic Education Rate: _____

- 2) Inclusive Education Program
 (Includes Educational Counseling (not ed related mental health) services, Speech & Language services, Behavior Intervention Planning, and Occupational Therapy as specified on the student's IEP.) DAILY RATE: _____

- 3) Related Services

<u>SERVICE</u>	<u>RATE</u>	<u>PERIOD</u>
<u>The Bay School Daily Rate</u>	<u>\$270.66</u>	<u>Day</u>
<u>Intensive Individual Services 1-1/day</u>	<u>\$264.27</u>	<u>Day</u>
<u>Intensive Individual Services 1-1/Hourly</u>	<u>\$42.00</u>	<u>Hour</u>
<u>Language and Speech</u>	<u>\$115.00</u>	<u>Hour</u>
<u>Adapted Physical Education (425)</u>	_____	_____
<u>Health and Nursing: Specialized Physical Health Care (435)</u>	_____	_____
<u>Health and Nursing: Other Services (436)</u>	_____	_____
<u>Assistive Technology Services (445)</u>	_____	_____
<u>Occupational Therapy</u>	<u>\$143.00</u>	<u>Hour</u>
<u>Physical Therapy (460)</u>	_____	_____
<u>Individual Counseling (510)</u>	_____	_____
<u>Counseling and Guidance (515)</u>	_____	_____
<u>Parent Counseling (520)</u>	_____	_____
<u>Social Work Services (525)</u>	_____	_____
<u>Psychological Services (530)</u>	_____	_____
<u>Behavior Intervention Services (535)</u>	_____	_____
<u>Specialized Services for Low Incidence Disabilities (610)</u>	_____	_____
<u>Specialized Deaf and Hard of Hearing (710)</u>	_____	_____

Interpreter Services (715)		
Audiological Services (720)		
Specialized Vision Services (725)		
Orientation and Mobility (730)		
Specialized Orthopedic Services (740)		
Reader Services (745)		
Transcription Services (755)		
Recreation Services, Including Therapeutic (760)		
College Awareness (820)		
Work Experience Education (850)		
Job Coaching (855)		
Mentoring (860)		
Travel Training (870)		
Other Transition Services (890)		
Other (900)		
Other (900)		

EXHIBIT B: 2022-2023 ISA

INDIVIDUAL SERVICES AGREEMENT (ISA) FOR NONPUBLIC, NONSECTARIAN SCHOOL SERVICES

(Education Code Sections 56365 et seq.)

This agreement is effective on July 1, 2022 or the date student begins attending a nonpublic school or receiving services from a nonpublic agency, if after the date identified, and terminates at 5:00 P.M. on June 30, 2023, unless sooner terminated as provided in the Master Contract and by applicable law.

Local Education Agency _____ Nonpublic School _____

LEA Case Manager: Name _____ Phone Number _____

Pupil Name _____ Sex: M F Grade: _____
 (Last) (First) (M.I.)

Address _____ City _____ State/Zip _____

DOB _____ Residential Setting: Home Foster LCI # _____ OTHER _____

Parent/Guardian _____ Phone () _____ () _____
 (Residence) (Business)

Address _____ City _____ State/Zip _____
 (If different from student)

AGREEMENT TERMS:

- Nonpublic School:* The average number of minutes in the instructional day will be: _____ during the regular school year
 _____ during the extended school year
- Nonpublic School:* The number of school days in the calendar of the school year are: _____ during the regular school year
 _____ during the extended school year
- Educational services as specified in the IEP shall be provided by the CONTRACTOR and paid at the rates specified below.*

A. **INCLUSIVE AND/OR BASIC EDUCATION PROGRAM RATE:** (Applies to nonpublic schools only): Daily Rate: _____

Estimated Number of Days _____ **x Daily Rate** _____ = **PROJECTED BASIC EDUCATION COSTS** _____

B. RELATED SERVICES:

SERVICE	Provider			# of Times per wk/mo/yr., Duration; or per IEP; or as needed	Cost per session	Maximum Number of Sessions	Estimated Maximum Total Cost for Contracted Period
	LEA	NPS	OTHER Specify				
Intensive Individual Services (340)							
Language/Speech Therapy (415) a. Individual b. Group							
Adapted Physical Ed. (425)							
Health and Nursing: Specialized Physical Health Care (435)							
Health and Nursing Services: Other (436)							
Assistive Technology Services (445)							
Occupational Therapy (450)							
Physical Therapy (460)							
Individual Counseling (510)							

SERVICE	Provider			# of Times per wk/mo/yr., Duration; or per IEP; or as needed	Cost per session	Maximum Number of Sessions	Estimated Maximum Total Cost for Contracted Period
	LEA	NPS	OTHER Specify				
Counseling and guidance (515).							
Parent Counseling (520)							
Social Work Services (525)							
Psychological Services (530)							
Behavior Intervention Services (535)							
Specialized Services for Low Incidence Disabilities (610)							
Specialized Deaf and Hard of Hearing Services (710)							
Interpreter Services (715)							
Audiological Services (720)							
Specialized Vision Services (725)							
Orientation and Mobility (730)							
Braille Transcription (735)							
Specialized Orthopedic Service (740)							
Reader Services (745)							
Note Taking Services (750)							
Transcription Services (755)							
Recreation Services (760)							
College Awareness Preparation (820)							
Vocational Assessment, Counseling, Guidance and Career Assessment (830)							
Career Awareness (840)							
Work Experience Education (850)							
Mentoring (860)							
Agency Linkages (865)							
Travel Training (870)							
Other Transition Services (890)							
Other (900)J							
Other (900)							
Transportation-Emergency b. Transportation-Parent							
Bus Passes							

SERVICE	Provider			# of Times per wk/mo/yr., Duration; or per IEP; or as needed	Cost per session	Maximum Number of Sessions	Estimated Maximum Total Cost for Contracted Period
	LEA	NPS	OTHER Specify				
Other							

ESTIMATED MAXIMUM RELATED SERVICES COSTS \$ _____

TOTAL ESTIMATED MAXIMUM BASIC EDUCATION AND RELATED SERVICES COSTS \$ _____

4. Other Provisions/Attachments:

5. MASTER CONTRACT APPROVED BY THE GOVERNING BOARD ON _____

6. Progress Reporting Requirements:	Quarterl y	Monthl y	Other (Specify)
-------------------------------------	---------------	-------------	--------------------

The parties hereto have executed this Individual Services Agreement by and through their duly authorized agents or representatives as set forth below.

-CONTRACTOR-		-LEA/SELPA-	
(Name of Nonpublic School/Agency)		(Name of LEA/SELPA)	
(Signature)	(Date)	(Signature)	(Date)
(Name and Title)		(Name of Superintendent or Authorized Designee)	

SANTA CRUZ CITY SCHOOL DISTRICT

AGENDA ITEM: CDW-G: SmartBus

MEETING DATE: August 17, 2022

FROM: Dorothy Coito, Assistant Superintendent of Educational Services

THROUGH: Kris Munro, Superintendent

RECOMMENDATION:

Ratify the summer deployment of Kajeet SmartBus on all 12 fully active district buses.

BACKGROUND:

For modern students, Internet access is essential for participating in remote learning, completing homework, and mastering digital skills. When buses are equipped with WiFi, students gain access to the Internet while traveling on daily routes, field trips, and athletic/club events. Students can connect to assignments, follow online teacher guides, visit educational portals, and more. Additionally, a safer experience is created when students are seated and engaged.

Each bus is equipped with both Verizon and AT&T antennae for maximum coverage. The bandwidth is nearly 1 Gbps. Kajeet SmartBus includes a firewall with customizable CIPA-compliant filters designed for K-12 to keep students safe and focused.

This contract is being ratified as the work was done during the summer months to maximize efficiency.

FISCAL IMPACT:

\$49,260.42 with \$8,436 annually recurring
Reimbursed 100% via ECF

This work is in direct support of the following District goals and their corresponding metrics:

Goal #1: All Santa Cruz City Schools students will be prepared to successfully access post-secondary college and career opportunities.

Goal #3: We will eliminate the achievement gaps that currently exist between demographic groups within the SCCS student community.

AGENDA ITEM: 8.2.1.2.

QUOTE CONFIRMATION



DEAR JIMMY MONREAL,

Thank you for considering CDW•G LLC for your computing needs. The details of your quote are below. [Click here](#) to convert your quote to an order.

QUOTE #	QUOTE DATE	QUOTE REFERENCE	CUSTOMER #	GRAND TOTAL
MVRH004	6/28/2022	KAJEET	1165316	\$49,260.42

QUOTE DETAILS				
ITEM	QTY	CDW#	UNIT PRICE	EXT. PRICE
Kajeet Cradlepoint COR IBR1700 Series Mobile Router Mfg. Part#: CS1700-12M Contract: MARKET	12	6606518	\$590.00	\$7,080.00
Kajeet IBR1700-1200 Wireless Router with 1 Year License Mfg. Part#: IBR170012 Contract: MARKET	12	6698913	\$1,856.00	\$22,272.00
Kajeet Sim Card for AT&T Mfg. Part#: NETATT Contract: MARKET	12	6043509	\$0.00	\$0.00
KAJEET NETWORK VERIZON Mfg. Part#: NETVZW Electronic distribution - NO MEDIA Contract: California NVP Software (ADSP016-130652 7-16-70-37)	12	6001961	\$0.00	\$0.00
Kajeet SmartBus 1700 External Antenna & Wiring Kit Mfg. Part#: SB1700HARD Contract: MARKET	12	6115645	\$572.00	\$6,864.00
KAJEET SMARTBUS INSTALLATION Mfg. Part#: SBINST Electronic distribution - NO MEDIA Contract: MARKET	12	5230479	\$516.00	\$6,192.00
KAJEET SMARTBUS UNLIMITED Mfg. Part#: SBUNL Electronic distribution - NO MEDIA Contract: California NVP Software (ADSP016-130652 7-16-70-37)	72	6717564	\$44.00	\$3,168.00

PURCHASER BILLING INFO	SUBTOTAL	\$45,576.00
Billing Address: SANTA CRUZ CITY SCHOOLS ACCOUNTS PAYABLE 133 MISSION ST STE 100 SANTA CRUZ, CA 95060-3747 Phone: (831) 429-3410 Payment Terms: NET 30 Days-Govt/Ed	SHIPPING	\$334.44
	SALES TAX	\$3,349.98
	GRAND TOTAL	\$49,260.42
	DELIVER TO	
Please remit payments to:		

Shipping Address:
 SANTA CRUZ CITY SCHOOLS WAREHOUSE
 Jimmy Monreal
 536 PALM ST
 SANTA CRUZ, CA 95060-4758
Shipping Method: DROP SHIP-GROUND

CDW Government
 75 Remittance Drive
 Suite 1515
 Chicago, IL 60675-1515

Need Assistance? CDW•G LLC SALES CONTACT INFORMATION



Chris Atraje

(877) 325-2820

chriatr@cdwg.com

LEASE OPTIONS

FMV TOTAL	FMV LEASE OPTION	BO TOTAL	BO LEASE OPTION
\$45,576.00	\$1,232.83/Month	\$45,576.00	\$1,420.60/Month

Monthly payment based on 36 month lease. Other terms and options are available. Contact your Account Manager for details. Payment quoted is subject to change.

Why finance?

- Lower Upfront Costs. Get the products you need without impacting cash flow. Preserve your working capital and existing credit line.
- Flexible Payment Terms. 100% financing with no money down, payment deferrals and payment schedules that match your company's business cycles.
- Predictable, Low Monthly Payments. Pay over time. Lease payments are fixed and can be tailored to your budget levels or revenue streams.
- Technology Refresh. Keep current technology with minimal financial impact or risk. Add-on or upgrade during the lease term and choose to return or purchase the equipment at end of lease.
- Bundle Costs. You can combine hardware, software, and services into a single transaction and pay for your software licenses over time! We know your challenges and understand the need for flexibility.

General Terms and Conditions:

This quote is not legally binding and is for discussion purposes only. The rates are estimate only and are based on a collection of industry data from numerous sources. All rates and financial quotes are subject to final review, approval, and documentation by our leasing partners. Payments above exclude all applicable taxes. Financing is subject to credit approval and review of final equipment and services configuration. Fair Market Value leases are structured with the assumption that the equipment has a residual value at the end of the lease term.

This quote is subject to CDW's Terms and Conditions of Sales and Service Projects at <http://www.cdw.com/content/terms-conditions/product-sales.aspx>
 For more information, contact a CDW account manager

© 2022 CDW•G LLC 200 N. Milwaukee Avenue, Vernon Hills, IL 60061 | 800.808.4239

Kajeet Services Agreement

This document contains certain terms of agreement between Kajeet Inc. a corporation organized under the laws of Delaware, with offices located at 7901 Branch Drive, #350, McLean, VA 22012 ("Kajeet") and Santa Cruz City School District, organized under the laws of CA, (the "Customer"), with offices located at 133 Mission St, Suite 100, Santa Cruz, CA 95060. Kajeet and Customer (the "Parties") desire to enter into a legally binding contract (the "Agreement") consisting of the provisions set forth below. Each of the Parties represents that it is in good standing, and it has the power to enter and perform this Agreement. Customer hereby designates Kajeet as a "school official" with "legitimate educational interests" in the Customer's educational records, as those terms have been defined under FERPA and its implementing regulations. Kajeet agrees to abide by FERPA limitations and requirements imposed upon school officials.

Program: **SmartBus** Data Plan: **Completed Unlimited Data Plan** Start Date: **TBD** Term: **Six (6) months**

Term The initial term of this Agreement commences on the selected date(s) and expires after the selected term length of service and it shall automatically renew on a month to month basis of service contingent upon receipt of a purchase order, unless terminated, extended, or altered, by either of the Parties.

Termination by Customer If for any reason Customer is dissatisfied with the level of service, Customer may terminate this agreement and if after notifying Kajeet, Kajeet fails to bring the level of service up to Customer's expectations within 30 days of such notification.

Termination by Kajeet Kajeet may terminate this Agreement after the initial term if Customer has no active service with Kajeet for a period of 180 days and, if after notifying Customer, Customer does not activate any devices within 30 days of such notification.

Effects of Termination In the event of termination, Kajeet will remove Customer's account and remaining balances from Kajeet's systems and Customer will return any Kajeet-Owned equipment to Kajeet within 30 days of termination. Purchased devices and services are nonrefundable.

Term Extension or Alteration by Customer Customer may extend or alter the term of the contract after the initial term by submitting a purchase order with term extension or alteration details, or authorizing a new services agreement.

Purchase Orders Customer may submit one (1) or more purchase orders at any time to request purchase of Kajeet devices and/or services. Such purchase order(s) will be considered binding upon Customer when submitted and binding upon Kajeet when accepted. Kajeet will indicate acceptance of such purchase order(s) by written notice and/or by invoicing customer against such purchase order(s).

Payment Terms Payments by Customer under this Agreement will be due when stated in each fully accepted purchase order or, if the purchase order does not state when particular payments are due, those payments will be due within thirty (30) days of Kajeet invoice.

Late Payments If Customer fails to make any payment when due, Kajeet will have the right, without prejudice to any other remedies it may have, to charge an additional fee equal to one-and-one-half percent (1.5%) of the overdue amount for each full or partial month that the amount remains unpaid.

Kajeet Complete™ Essentials Plan This service is intended for educational use only and Customer agrees to adhere to Kajeet standard CIPA-compliant and education content filters, time-of-day access settings, and that each device will be used by no more than one user at any given time. In the event Kajeet detects bandwidth consumption inconsistent with single-user educational use, Kajeet may temporarily reduce or restrict services while conducting further review. The Complete Essentials Plan has a 500MB per day data consumption limit. Video may stream at 480p. YouTube® access is blocked by default. Customers on the Complete Essentials Plan can purchase an optional add-on service to gain access to YouTube. If the Customer selects to have open access to YouTube services, Customer indemnifies and holds Kajeet harmless from any inappropriate content viewed by the end-user on YouTube.

Kajeet Unlimited Plans The Student Unlimited, Home Unlimited, and SmartBus Unlimited Plans are intended for educational use only and Customer agrees to adhere to Kajeet standard CIPA-compliant and education content filters, and time-of-day access settings. The Student Unlimited Plan may be used by no more than one user at any given time. The Home Unlimited Plan may only be used by students in the same household. The SmartBus Unlimited Plan is only intended to provide Wi-Fi for bus riders. In the event Kajeet detects bandwidth consumption inconsistent with plan terms, Kajeet may temporarily reduce or restrict services during review. Video may stream at 480p. YouTube® access is blocked by default. Customers on Kajeet Unlimited Plans may request open access to YouTube at no additional charge. If the Customer selects to have open access to YouTube services, Customer indemnifies and holds Kajeet harmless from any inappropriate content viewed by the end-user on YouTube.

Kajeet Custom™ Plans Kajeet default filters, policy controls, and time-of-day settings can be altered to fit the customer's specific use case. Any alterations to Kajeet default controls may result in higher than anticipated data usage. All data purchased is pooled on the customer account at the start of the agreement term. Data may be shared among all devices on the account. During the active agreement term, un-used data rolls-over to the next month. At the end of the service term, unused data expires. Unused data cannot be returned for a refund or credit. A new pool of shared, roll-over data must be purchased for the subsequent service term.

Device Warranties and Non-Return Policy Kajeet warrants that devices sold to Customer will be free from defects in materials and workmanship for a period of one (1) year after shipment by Kajeet. At its option, Kajeet will either repair or replace any device failing to meet this warranty if Customer notifies Kajeet of the defect before the warranty period expires. Customer acknowledges that replacements may be new or refurbished. Customer agrees to obtain return authorization from Kajeet prior to returning a device and to bear the cost of shipping the device to Kajeet and to bear the risk of loss during transit. Customer agrees that Kajeet will have no warranty obligations due to defects resulting from (i) ordinary wear and tear; (ii) modifications or repairs made by anyone other than Kajeet or its authorized service technicians; and/or (iii) accident or abuse. All sales of Customer purchased devices are final and cannot be returned for a refund. Chromebook, laptop, or tablet warranty and service issues are honored and handled via the manufacturer and not directly by Kajeet.

Applicable Law The Parties intend that the laws of the State of Customer should be used to interpret and enforce this Agreement.

ACCEPTED BY: /s/

Authorized Customer Signature

Print Name

Date

SANTA CRUZ CITY SCHOOL DISTRICT

AGENDA ITEM: Consultant Service Agreements: Santa Cruz High School

MEETING DATE: August 17, 2022

FROM: Dorothy Coito, Assistant Superintendent of Educational Services

THROUGH: Kris Munro, Superintendent

RECOMMENDATION:

Ratify the Consultant Services Agreements for The Fischer Agency Program & Motivation LLC

BACKGROUND:

Monti Washington is a motivational and goal setting speaker recognized around the nation for his message of perseverance and resilience. Mr. Washington will spend time on the first day of school at Santa Cruz High School speaking at a student assembly to inspire students and provide them with specific skills on how to be a successful student. This contract is coming for ratification because the contract was not secured before the final board meeting in June 2022.

FISCAL IMPACT:

\$4,750 Donation Fund (Restricted)

This work is done in support of the following district goals and their corresponding metrics:

Goal #1: All Santa Cruz City Schools students will be prepared to successfully access post-secondary college and career opportunities.

Goal #2: SCCS will create positive, engaging school environments that promote the development of cognitive skills and the social emotional well-being of all students.

REQUEST FOR CONSULTANT SERVICES AGREEMENT

Submit to the responsible Assistant Superintendent at least two weeks before the Board meeting and prior to the Consultant beginning work.

Site: SCHS Principal/Director: Michelle Poirier

Describe Work to be Performed and District and Site Goals Supported:
Monti Washington will provide a 50 minute opening-of-school keynote speech and remain after the speech to meet with students during lunch time.

Qualifications of Consultant: Experienced motivational speaker and actor

Name of Consultant: The Fisher Agency Program Tax I.D.# or SSN: 32-0040245
(Vendor Data form to Purchasing)

Address: P.O. Box 1488 Telephone #: 800-541-4660

City/State/Zip: Lafayette, CA 94549 Email: chris@tfaspeakers.com

Date(s) of Service: August 10, 2022 Time: 11:00 AM - 1:00 PM

Number of Hours: _____ hours per day X _____ days = _____ total hours.

Hourly/Daily Rate (specify): \$4750 (daily) Meals: n/a

Lodging: n/a Transportation: n/a

TOTAL FEE TO BE PAID: \$4750 Account #: 01-9016-0-1110-1000-5800-07A

Write out meaning of account number: Dwyer Family Donation Account -3A12

Approval of Business Services verifying account: _____ Date: _____

Authorized Signature of Consultant: [Signature] Date: 7/20/22
(NOTE: Consultant must submit invoice for payment upon completion of work)

Signature of Administrator Requesting Service: _____ Approval of Assistant Superintendent: _____

Date: July 19, 2022 Date: _____

AB 1610, 1612, and 2102 COMPLIANCE (consultants having more than limited contact with students require fingerprinting)

- Consultants *will be* on campus on a regular basis (more than once) while students are present
- Consultant *will not be* on campus on a regular basis while students are present (fingerprints not required).

Fingerprint Clearance date: _____ Approval of Human Resources: _____

PAYMENT AUTHORIZATION
(Submit for payment after Consultant completes work)

I hereby certify that the consultant has satisfactorily completed the services in accordance with the above Agreement and that payment is in order.

Signature of Administrator Requesting Payment: [Signature]

July 19, 2022
Date

Approval of Assistant Superintendent: [Signature]

7/26/22
Date

Board of Education Approval: _____
(Required if over \$2500)

REQUEST FOR CONSULTANT SERVICES AGREEMENT

Review guidelines of Board Policy - Consultant Services Agreements.

1. Statement of specific need and the goal of the Consultant's work (Refer to district/site goals and plans, unique needs of school, program or office which necessitates the services of a consultant).
SCCS Strategic Goal 1: All SCCS students will be prepared to successfully access post-secondary college and career opportunities.
SCCS Strategic Goal 2: SCCS will create positive, engaging school environments that promote the development of cognitive skills and the social emotional well-being of all students.
SCCS Strategic Goal 6: SCCS will maintain strong communication and partnerships with its diverse community.
SCHS Goal 1: Improve school climate and culture by providing opportunities for student voice, participation, and ownership of learning while challenging and supporting students in their personal and academic growth.

2. State efforts made to identify qualified staff available within the district to carry out the requested services.
Within the school and district, there are no persons who can provide a growth message within the relating of an inspirational personal story and with an engaging presentation.

3. If this agreement is for staff development or for one-time services, state the site's plan to reduce or eliminate the need for this consultant's services in the future.
N/A

4. Statement of expected outcomes (Include specific student outcomes desired, benefits to district students and/or staff).
Students will gain a sense of belonging to the Santa Cruz High School community of students and adults. Students will be inspired to persevere through adversity to set and reach for personal life goals.

5. Evaluation Process - How will you know the goal/outcomes have been met?
Student survey gauging effectiveness of speaker

1. Contact Information SPEAKER to be sent your signed copy by TFA. Please review and complete details.

Speaker Monti Washington **Date** August 10, 2022 **Day** Wednesday
Sponsor Santa Cruz High School
Type of Event Back to School Assembly
Contact Person Michelle Poirier **Title** Principal
Contact Person #2 Katie Rowe-Kairys - Activities Director katherinerowe-kairys@sccs.net
Address 415 Walnut Ave.
Santa Cruz CA 95060
Work Phone 831-429-3960 ext. 50201 **Cell Phone** _____
FAX NA michellepoirier@sccs.net

2. Programs Details Speaker will arrive 30 minutes early to check sound system and to meet Contact Person.

Beginning Time 11:19 a.m. **Completion Time** 12:09 p.m.
Speech Site Same as above.
Location Phone Same as above
Assignment Details Monti Washington will present one 50 minute assembly as discussed between Michelle Poirier and Monti Washington.
11:19 a.m. to 12:09 p.m.
Monti can stay after he speaks to speak with students directly at lunch time.
Audience _____ of students

3. Payment Terms Please contact this office soon as possible if payment can not be made as requested.

\$ 4750.00 for services, as described in Section 2. INCLUSIVE
Fee & Travel A separate TRAVEL EXPENSE INVOICE will be sent to you either before or immediately after the speaking engagement. Travel to be prorated whenever possible. The basic travel expenses for the SPEAKER you selected includes:
NA - NO TRAVEL
Signed Agreement A signed Program Agreement must be returned by in order for the _____ ASAP SPEAKER to consider the date FIRM. A FAX copy is acceptable and binding. _____
HOLDING DEPOSIT of \$ 2375.00 or Purchase Order is required by _____ ASAP
Holding Deposit Issue check directly to The Fisher Agency tax ID 32-0040245
Fee Balance FEE BALANCE of \$ 2375.00 to be paid on or before date of engagement.
Issue this check payable directly to Monti Washington Tax ID # 601-26-5120
Special Note
* Money paid in advance will be held in an escrow-type account and released upon completion of work.

4. Airport Information

Airport San Jose, CA

Driving Time from Airport 45 Minutes

Flight Times

Upon Arrival at Airport

Monti will secure ground transportation.

5. Directions for Driving

NA

6. Hotel Contact Person is to make hotel reservations (non-smoking room secured for late arrival) and fill in Section 6.

Hotel NA

Confirmation #

Address

Date of Hotel

Hotel Phone

7. Additional Terms:

Please review these terms as each point is very important to your Speaker.

- 1 Audio or video taping of the SPEAKER'S program is allowed only when written permission has been granted by the SPEAKER, and the SPEAKER is guaranteed a first generation copy for his/her files.
- 2 Additional program requested of SPEAKER, outside the terms of this Program Agreement, is subject to additional fee consideration per hour -- as stated by SPEAKER at the time of SPONSOR'S request.
- 3 Audio-video requirements include a quality sound system, hand-held or lavalier microphone (cordless or 50 feet of cord), full house lights, and if needed for good visibility of the SPEAKER, a raised platform stage. If a gymnasium is being used, please seat audience on one side of the bleachers with the overflow seated on floor level.
- 4 If agreement is canceled by SPONSOR and the date is not resold, the following percentage of the fee will be in effect from the time notification is given to Chris Fisher at The Fisher Agency: 3 weeks or less prior to scheduled engagement = 100% plus airline penalties incurred by Speaker, 31 days or more = 50% plus airline penalties. If date is resold, Holding Deposit can be reapplied to future booking, within a year, with the same SPEAKER.
(** CANCELLATION MUST BE DONE IN WRITING)
- 5 If SPEAKER cancels due to unforeseen personal emergency or airline/weather complications, The Fisher Agency will make its best effort to find a speaker, for this event, of equal value/talent that is acceptable to the client or immediately refund the Holding Deposit. If another speaker is not located, no further payment by SPONSOR is required.
6. If SPEAKER has commenced travel to your event, and engagement is canceled due to an Act of Mother Nature (example - ice storm, earthquake) or dangerous situation (example - riots, violence), SPONSOR will be responsible for travel expenses incurred by SPEAKER. SPEAKER'S fee will not be charged, the Holding Deposit (if collected) will be applied to travel expenses, and any excess funds from the Holding Deposit will be refunded to SPONSOR.

8. Additional Details

Michelle - Thank you for inviting Monti Washington to speak to your students at Santa Cruz High School. I am sure your program with Monti will be a huge success!

***Michelle - Please sign and fill in any missing details on this PROGRAM AGREEMENT.

If details on this Agreement do not agree with your records, please contact this office immediately. Fill in missing details (times, directions, etc.). Return a signed copy by mail or e-mail, and process all invoices so payments are on time. Thank you!

Authorized Signatures and Dates

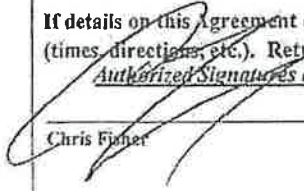
 Chris Fisher
 Date 7/18/22

 Michelle Poirier
 Date 7/19/22

PROGRAM REQUIREMENTS FORM ...

Monti Washington

We want your program to be a great success! To do so, the speaker you select needs your assistance in fulfilling the following requirements. Please sign to confirm that you will meet these requirements and return with your Program Agreement. Please contact The Fisher Agency if you are not able to meet each request. We will notify the Speaker so an alternative solution can be agreed upon in advance. Thank you for your cooperation. TFA

Signature: [Handwritten Signature] Title: principal Date: 7/19/22

2 bottles of water

Mic

Computer that Monti can use for Music

The Fisher Agency * 1-800-541-4660 * info@tfaspeakers.com

The Fisher Agency
Holding Deposit Invoice

P.O. Box 1488 * Lafayette, CA 94549
800-541-4660
E-mail info@tfaspeakers.com

Record # CF229880
June 13, 2022

To:

Sponsor Santa Cruz High School
Contact Person Michelle Poirier Principal
415 Walnut Ave.

Santa Cruz CA 95060

For professional services of:

Speaker Monti Washington Date August 10, 2022
Fee \$ 4750.00
Speech Location Same as above.

Type of Event Back to School Assembly

TERMS: In order to confirm the date on SPEAKER'S calendar, a Holding Deposit is required, as explained in Section 5 of the Program Agreement. **Please make the deposit payable to:**

The Fisher Agency -- Tax Identification #32-0040245

Holding Deposit Due Date: ASAP
Deposit \$ 2375.00

The Fisher Agency
Fee Balance Invoice

800-541-4660
E-mail info@tfaspeakers.com

June 13, 2022

To:

Sponsor Santa Cruz High School
Contact Person Michelle Poirier Principal
415 Walnut Ave.

Santa Cruz CA 95060

For professional services of:

Speaker Monti Washington
Date August 10, 2022
Speech Location Same as above.

Type of Event Back to School Assembly

TERMS: Speaker's fee balance is due and payable ON or BEFORE:

August 10, 2022

**Make this check payable to:
Tax ID Number:**

Monti Washington
601-26-5120

2375.00

Fee Balance \$

SANTA CRUZ CITY SCHOOL DISTRICT

AGENDA ITEM: iStation License Agreement

MEETING DATE: August 17, 2022

FROM: Dorothy Coito, Assistant Superintendent of Educational Services

THROUGH: Kris Munro, Superintendent

RECOMMENDATION:

Approve iStation contract for DeLaveaga Elementary School.

BACKGROUND:

iStation is a program that has been used by DeLaveaga’s Two-Way Immersion Program for the past five years. The program supports Spanish language instruction through a virtual medium. Teachers of the Two-Way Immersion Program have requested that this program be provided to support their students’ Spanish language acquisition.

Powered by the science of reading, iStation’s engaging assessments and instruction cover the National Reading Panel’s “Big Five” foundational essentials. Schools get the support they need to improve comprehension and growth with activities and lessons that provide actionable and insightful data that measures phonemic awareness, phonics, fluency, comprehension, and vocabulary, as well as many other skills.

FISCAL IMPACT:

\$8,284.00 annually ESSER3 (Restricted)

This work is in direct support of the following District goals and their corresponding metrics:

Goal #1: All Santa Cruz City Schools students will be prepared to successfully access post-secondary college and career opportunities.

Goal #3: We will eliminate the achievement gaps that currently exist between demographic groups within the SCCS student community.

8.2.1.4.

AGENDA ITEM:



**Superheroes
Can Do Anything!**



Every Student Deserves to Feel Powerful!

Discover hidden strengths with dynamic intervention and instruction.

Quote Q-41846-2

Prepared For:

De Laveaga Elementary

1145 Morrissey Blvd

Santa Cruz, CA

95065-1498

US

Your Istation Partner:

Joe Dominguez

Account Executive

joe.dominguez@istation.com

+1 9162571534



BBB Rating: A+



8150 North Central Expressway, Suite 2000
 Dallas, TX 75206
 Phone: 1-866-883-READ (7323)
 Email: orders@istation.com

Quote: Q-41846-2
Prepared For: De Laveaga Elementary
Expires On: 8/31/2022

DISCLAIMER: Pricing is as quoted and subject to change with any edits to bundle configurations, enrollment updates, or other revisions. Taxes in particular, if applicable, should be verified before issuing any PO.

IE.Student - Lectura (Student Account)

QTY	PRODUCT	Start Date	Months	End Date	CAMPUS	PRICE
242	IE.Student - Lectura (Student Account)	8/1/2022	12	7/31/2023	De Laveaga Elementary	\$6,534.00
IE.Student - Lectura (Student Account) TOTAL:						\$6,534.00

Standard Virtual Learning Services

8 months of Virtual Learning including on-boarding, two webinars, and additional assistance as needed by a designated Implementation Specialist for new or continued Istation supporters. Must be used in current subscription term.

QTY	PRODUCT	Start Date	Months	End Date	CAMPUS	PRICE
1	Standard Virtual Learning Services	8/1/2022	12	7/31/2023		\$1,750.00
Standard Virtual Learning Services TOTAL:						\$1,750.00

SUBTOTAL:	\$8,284.00
TAX (if applicable):	
CUSTOMER TOTAL:	\$8,284.00



8150 North Central Expressway, Suite 2000
 Dallas, TX 75206
 Phone: 1-866-883-READ (7323)
 Email: orders@istation.com

Quote: Q-41846-2
Prepared For: De Laveaga Elementary
Expires On: 8/31/2022

DISCLAIMER: Pricing is as quoted and subject to change with any edits to bundle configurations, enrollment updates, or other revisions. Taxes in particular, if applicable, should be verified before issuing any PO.

Additional Options (to be paid in full). Totals do not include tax (if applicable):

Choose 1, 2, or 3 year Subscription						
		<u>1 YEAR SUBSCRIPTION</u>		<u>2 YEAR SUBSCRIPTION</u>		<u>3 YEAR SUBSCRIPTION</u>
Additional Discount Amount:		<i>Quoted Price</i>		(\$497.04)		(\$1,491.12)
% Discount:		<i>Quoted Price</i>		3.00%		6.00%
Your Total Cost:		\$8,284.00		\$16,070.96		\$23,360.88

Subscription Start Date: 8/1/2022 Subscription Term: 12 Subscription End Date: 7/31/2023

Please email or fax the following items to 214-291-5534 or orders@istation.com. Failure to provide the below will cause a delay in processing your order.

- Signed Purchase Order that includes the quote number
- Signature page of this Quote (choose subscription length)

IN WITNESS WHEREOF, the Parties have caused this Agreement to be executed and delivered by their respective authorized representatives whose signatures appear below.

Istation

De Laveaga Elementary

Signature: _____
 Printed Name: _____
 Title: _____
 Dated: _____

Signature: _____
 Printed Name: _____
 Title: _____
 Dated: _____
 PO # (if available): _____

To ensure timely fulfillment, please provide the requested contact information below:

Primary Implementation Contact

Accounts Payable / Billing Contact

Name: _____
 Email: _____
 Phone: _____

Name: _____
 Email: _____
 Phone: _____

District Technology Contact

District Data Contact

Name: _____
 Email: _____

Name: _____
 Email: _____

Phone:

Phone:



8150 North Central Expressway, Suite 2000
Dallas, TX 75206
Phone: 1-866-883-READ (7323)
Email: orders@istation.com

Quote: Q-41846-2
Prepared For: De Laveaga Elementary
Expires On: 8/31/2022

TERMS OF USE:

The following Terms of Use and Service (these "Terms") are important. Please read carefully.

Istation provides customers with a variety of resources, including, but not limited to, (i) one or more of Istation's interactive educational-based applications (collectively the "**Licensed Applications**"), (ii) Istation's Internet Web site (the "**Web Site**"), currently located at www.istation.com, (iii) account information regarding the Licensed Applications and the Web Site, (iv) materials and documentation (including, but not limited to, preprinted forms, form letters, resource materials, lesson plans, books, images of Istation characters, and so-called "Black Line Masters" coloring-book style pictures) available from the Web Site (collectively the "**Downloadable Materials**"), (v) reports, calculated results, scoring, graphs and any other materials derived from Istation's algorithmic software features (collectively the "Scoring and Reporting Resources"), (vi) Processed Data, as defined hereinafter, and (vii) news and information about Istation, the Licensed Applications, and the Web Site. Any and all of the foregoing resources (including, but not limited to, the Licensed Applications, the Web Site, and the Downloadable Materials), together with any other resources made available by Istation, are collectively the "**Resources**".

For purposes of these Terms, references to "**You**" or "**Your**" mean (i) you in your individual capacity, (ii) your company ("**Your Company**"), which may be a school or school district, and (iii) authorized users of Your Company, who are students, employees, representatives, and agents of Your Company that are registered with Istation and that have a valid security identification and password to access and use the Resources (collectively the "**Authorized Users**").

Each of the Resources is provided to You conditioned on Your acceptance, without modification, of these Terms, which constitute a legally binding agreement between Istation and You. YOUR ACCESS OR USE OF ANY RESOURCE CONSTITUTES YOUR AGREEMENT TO BE BOUND BY THESE TERMS FOR ALL RESOURCES. IF YOU DO NOT AGREE TO THESE TERMS, YOU MAY NOT ACCESS OR USE ANY RESOURCE. WITHOUT LIMITING THE GENERALITY OF THE FOREGOING, THESE TERMS SHALL BE BINDING ON YOU UPON THE EARLIER TO OCCUR OF (i) YOUR EXECUTION OF THESE TERMS, (ii) THE DATE THAT YOU DOWNLOAD ANY LICENSED APPLICATION OR DOWNLOADABLE MATERIAL FROM Istation, (iii) THE DATE OF DELIVERY OF ANY LICENSED APPLICATION OR DOWNLOADABLE MATERIAL BY Istation TO YOU, AND (iv) THE DATE ON WHICH YOU ACCESS OR USE ANY OF THE RESOURCES THROUGH THE WEB SITE.

1. **Changes to Terms.** Istation may, from time to time and at Istation's sole discretion, modify these Terms without individual notice to You. So long as the Web Site remains operational, the current version of these Terms will be posted on the Web Site, which You can review by clicking on the "Terms of Use" link located on the Web Site. The modified Terms will be effective immediately upon posting on the Web Site. You agree to the new posted Terms by continuing Your use of the Resources. You agree to review the Terms periodically on the Web Site. If You do not agree with the modified Terms posted on the Web Site, Your only remedy is to discontinue using the Resources.
2. **Privacy Statement.** Istation's Privacy Statement (the "**Privacy Statement**") is incorporated into, and made a part of, these Terms. The Privacy Statement relates to Istation's collection and use of Your personal information. You consent to the terms and conditions of the Privacy Statement.
3. **Subscription.**
 1. Most (if not all) of the Resources require You to purchase a subscription from Istation before You may use or access them (a "**Subscription**"). You may purchase a Subscription to one or more Resources (the "**Purchased Resources**") by paying the then-current subscription fee to Istation (the "**Subscription Fee**") for such Purchased Resources, as such Subscription Fee is determined by Istation. Each Subscription Fee shall cover a specified period of time for the Purchased Resources (the "**Subscription Period**"). Upon expiration of the Subscription Period for a Purchased Resource, Your access and use of the Purchased Resources shall expire, and You shall no longer be entitled to access or use such Purchased Resources, unless You renew Your Subscription to such Purchased Resources by paying the then-current Subscription Fee for such Purchased Resources. Any Professional Development purchases including Onsite Training, Webinars, and Implementation services must also be used within the current Subscription Period and may not be rolled over into later Subscription Periods. Istation may, from time to time and at Istation's sole discretion, modify the Subscription Fees for any and all Resources without individual notice to You.
 2. In the event You purchase a Subscription to a Purchased Resource, You will be required to register (the "**Registration**") and obtain a user account (a "**User Account**") for each Authorized User's access to, and use of, such Purchased Resource provided, however, that each Purchased Resource may, as determined by Istation, (i) be limited to a maximum number of Authorized Users (such as students) and (ii) have other restrictions applicable to such Purchased Resource. During Registration for each and every Purchased Resource, You agree to submit accurate, current, and complete information about You (including, but not limited to, Your Company and the Authorized Users) and promptly update such information. Should Istation suspect that any such Registration information is untrue, inaccurate, not current, or incomplete, Istation has the right to suspend or terminate use of any and all Resources and User Accounts. Upon Registration, each Authorized User will be assigned a personal, nontransferable password tied to a specific User Account. You are solely responsible for (i) any and all activities that occur under the User Accounts and (ii) ensuring that Authorized Users exit or log off from User Accounts at the end of each session of use. User Accounts cannot be shared and may be used only by the Authorized User to whom the User Account is registered. User Accounts cannot be assigned to any third party vendors or other entities seeking to use the Purchased Resources for use in their products and/or for commercial use or monetary gain. You shall notify Istation immediately of any unauthorized use of the Authorized Users' passwords or the User Accounts or any other breach of security that is known or suspected by You. Where the number of Authorized Users for a Purchased Resource falls below the maximum number permitted under Your Subscription for such Purchased Resource, You may designate other students as replacement Authorized Users with respect to such Purchased Resource. You are responsible for Registration of all Authorized Users and all acts and omissions (whether authorized or unauthorized) of the Authorized Users.
4. **Intellectual Property.**
 1. Istation Intellectual Property. All Resources (including, but not limited to, the Licensed Applications, the Web Site, the Downloadable Materials, and the Scoring and Reporting Resources), and all materials displayed on, or contained within, the Resources (including, but not limited to, the Licensed Applications, the Web Site, and the Downloadable Materials, Scoring and Reporting Resources), such as the

design, “look and feel”, text, editorial materials, informational text, photographs, illustrations, artwork and other graphic materials, audio, video, names, logos, trademarks, and service marks of or on the Resources (collectively the “**Resource Materials**”), whether publicly posted or privately transmitted, as well as all derivative works of the Resources and the Resource Materials, are the exclusive property of, and exclusively owned by, Istation and Istation’s licensors and are protected by copyright, trademark, trade secret, and other intellectual property laws. The Istation name, designs, and related marks contained within the Resources and the Resource Materials are trademarks of Istation and Istation’s licensors. You do not acquire any ownership rights in or to the Resources or any Resource Materials through Your access to, or use of, the Resources, and You possess only those limited rights expressly granted to You in these Terms. Istation reserves all right, title, and interest in and to the Resources and the Resource Materials.

2. Your Data. As between You and Istation, You are and will remain the owner of all right, title, and interest in and to all of Your Data. For purposes of these Terms, “**Your Data**” means information, data, and other content that is collected, downloaded, or otherwise received, directly or indirectly from You or an Authorized User by or through the Purchased Resources. Notwithstanding the foregoing, Your Data shall not include any information, data and other content that incorporates or is otherwise derived from the processing of such information, data, and content by or through the Purchased Resources (the “**Processed Data**”).
5. **License.** Subject to compliance with the Subscription and Registration terms and conditions contained in Section 3 (Subscription), including, but not limited to, possessing a valid User Account and related password and restricting access and use to Authorized Users, Istation grants to You a personal, limited, nonexclusive, nontransferable, and revocable license to access and use the Purchased Resources and related Resource Materials, but only during the Subscription Period applicable to each such Purchased Resource, solely for Your educational purposes and subject to these Terms.

6. **Restrictions.**

1. Any copies that You make of the Resources or the Resource Materials must retain all proprietary, copyright, trademark, or service mark legends and other notices.
2. Access and use of the Resources and the Resource Materials is permitted only as expressly provided in these Terms.
3. You may not (i) upload, post, publish, transmit, distribute, disseminate, display, perform, disclose, rent, lease, modify, loan, broadcast, or circulate any Resource or any Resource Material, (ii) operate or make available any Resources or any Resource Material in a service bureau, time-sharing, or other managed services environment, (iii) participate in the transfer, sublicense, assignment, or sale of any Resource or any Resource Material, (iv) access or use any Resource or Resource Material for purposes of competitive analysis of the Resource, Resource Materials, or Purchased Resources, or use or provide third-party access to Your Data or Processed Data, either directly or indirectly, for the development, provision, advertising, marketing, or use of a competing software service or product or any other purpose that is to the Istation’s detriment or commercial disadvantage, or (v) modify or create any derivative work of any Resource or any Resource Material or in any way exploit any Resource or any Resource Material provided, however, that You may download and use the Downloadable Materials in furtherance of Your education of the Authorized Users who are students, subject to any instructions or limitations provided with, or as part of, such Downloadable Materials.
4. You may not use any of the trademarks of Istation, or Istation’s licensors, suppliers, or service providers, contained in any Resource or any Resource Material. No portion of the Resources or the Resource Materials may be stored in a computer except for educational and noncommercial use.
5. You may not copy the Resource or the Resource Materials provided, however, that You may copy the Downloadable Materials in furtherance of Your education of the Authorized Users who are students, subject to any instructions or limitations provided with, or as part of, such Downloadable Materials.
6. You may not disassemble, decompile, or reverse engineer any Resource or any Resource Material or otherwise attempt to determine the makeup or source code of any Resource.
7. You may not upload any data, including any and all of Your Data, to, or otherwise access or use, any Resource or Resource Material in any manner that would materially impact the operation of such Resource or Resource Material.
8. You may not allow access to, disclose or otherwise provide Processed Data to any third-party except for use in connection with and for the benefit of Your internal business purposes i.e. research. In no manner shall you allow or assign access to any of the Purchased Resources or Resource Materials, including but not limited to, the Reporting and Scoring Resources or Processed Data, for any third party vendors entities or other persons seeking to use for their own products or services, for commercial use or monetary gain, or otherwise.
9. Any deviations from any of these Terms require prior written consent from Istation.

7. **Conduct.**

1. You agree not to (or permit anyone else to) (i) upload, transmit, post, e-mail, or otherwise make available through the Resources any content or other material in any format that (a) is illegal, false, inaccurate, unlawful, harmful, hateful, threatening, abusive, harassing, tortious, defamatory, vulgar, obscene, profane, offensive, pornographic, invasive of another's privacy, libelous, or otherwise objectionable or inappropriate or (b) contains any viruses, worms, Trojan horses, corrupted files, or any other similar software or programs designed to interrupt, destroy, or limit the functionality of any computer software or hardware or telecommunications equipment; (ii) alter, remove, or falsify any attributions or other proprietary designations of origin or source of any other content appearing in or on the Resources or the Resource Materials; (iii) take any action that imposes an unreasonable or disproportionately large load on Istation’s infrastructure; (iv) use any automated means to download data from any of the Resources’ databases or engage in any data gathering, mining, harvesting, or extraction methods from any Resource for any purpose; (v) impersonate another person or entity or use any fake name or identity; (vi) allow any other person or entity to use Your identification or User Account for any purpose; or (vii) violate any applicable law, rule, regulation, or right, including, but not limited to, intellectual property and privacy rights. The use of any device, software, or routine that interferes or attempts to interfere with the proper working of any Resource is expressly prohibited.
2. By posting, uploading, inputting, providing, or submitting information, data (including, but not limited to, Your Data, student data or student information, such as personally identifiable information about students and writings prepared by students), or materials to or through any Resource (including, but not limited to, through the Web Site) (collectively the “**Submissions**”), You are granting Istation, Istation’s affiliated companies, and necessary sublicensees, subject to the Privacy Statement, irrevocable permission to use in perpetuity, without compensation and without restriction (including, but not limited to, a worldwide, transferable, perpetual, royalty-free, fully paid-up license), Your Submissions, including, but not limited to, the rights to copy, distribute, transmit, publish, publicly display, use, publicly perform, reproduce, edit, translate, reformat, modify, and prepare derivative works of Your Submissions. No compensation will be paid with respect to the use of Your Submissions. Istation is under no obligation to post or use any Submission You may provide. By posting, uploading, inputting, providing, or submitting Your Submissions, You represent and warrant that (i) You own or otherwise control all of the rights to Your Submissions as described in these Terms, (ii) such Submissions comply with these Terms, including Section 7(a) of these Terms, (iii) You have all necessary right and authority (including, but not limited to, all third-party consents) to post, upload, input, provide, and submit the Submissions, and (iv) with respect to Submissions of personal information of a child under 13 years of age, You have requested and received parental consent of such Submissions in compliance with, and such Submissions otherwise in compliance with, the Children’s Online Privacy Protection Act of 1998 (“**COPPA**”) and COPPA’s rules and regulations.

8. **Security.**

1. Istation will take commercially reasonable precautions to secure the Web Site against (i) unauthorized access by third parties and by unauthorized Istation employees, (ii) damage, disruption, and other activity aimed at Resource availability, and (iii) trespass or illegal actions. Istation reserves the right to temporarily deny and cancel access privileges for anyone suspected of attempting to work outside parameters that threaten the security of the Resource, the Resource Materials, Your Submissions (including, but not limited to, data submitted by You), or Istation's providing the Resources.
2. NOTWITHSTANDING SECTION 8a, YOU ACCEPT SOLE RESPONSIBILITY FOR THE ACCURACY, ADEQUACY, AND LEGALITY OF, AND LIABILITIES ASSOCIATED WITH, YOUR SUBMISSIONS (INCLUDING, BUT NOT LIMITED TO, DATA SUBMITTED BY YOU AND WRITINGS PREPARED BY STUDENTS) AND FOR ALL RESULTS OBTAINED THEREFROM. You are liable for any and all expenses, losses, damage to the reputation of Istation, and damages to the Resources, the Resource Materials, or components thereof arising out of, or caused by, the negligent or willful misconduct of You or Your agents. Istation assumes no liability for any damages You may suffer as a result of interception, alteration, or misuse of any information transmitted over the Internet.

1. **No Control over Submissions.**

1. Istation HAS NO CONTROL OVER YOUR SUBMISSIONS AND IS NOT RESPONSIBLE FOR ANY SUBMISSIONS (SUCH AS STUDENT DATA OR WRITINGS PREPARED BY STUDENTS), INCLUDING, BUT NOT LIMITED TO, SUBMISSIONS THAT (i) ARE DISCOVERED TO BE INACCURATE OR MISSING, (ii) ARE CORRUPTED DUE TO TECHNOLOGICAL OR OTHER CAUSES BEYOND THE REASONABLE CONTROL OF Istation, AND (iii) CONTAIN OFFENSIVE OR INAPPROPRIATE LANGUAGE OR THREATS OR ACTS OF VIOLENCE.
2. Istation reserves the right to take archiving and other measures that Istation deems necessary in order to ensure high-quality server performance and maintenance of Istation's servers.

2. **No Endorsement of Third-Party Sites.**

1. The Web Site may reference or contain links to third-party Web sites, resources, and advertisers (collectively "Third-Party Sites"). Your linking to such Third-Party Sites is at Your own risk. Istation is not responsible for the accuracy or reliability of any content, data, opinions, advice, statements, or other information on the Third-Party Sites. Istation also is not responsible for the availability of these Third-Party Sites, nor is Istation responsible for the aesthetics, appeal, suitability to taste, or subjective quality of informational content, advertising, products, or other materials made available on or through such Third-Party Sites. No endorsement of any third-party content, information, data, opinions, advice, statements, goods, services, or products is expressed or implied by any information, material, or content of any third party contained in, referred to on, included on, or linked from or to the Web Site. Under no circumstances shall Istation or any affiliated providers be held responsible or liable, directly or indirectly, for any loss, injury, or damage caused or alleged to have been caused to You in connection with the use of, or reliance on, any content, information, data, opinions, advice, statements, goods, services, or products available on such Third-Party Sites. You should direct any concerns to the respective Third-Party Site's administrator or Webmaster. Any links to Third-Party Sites do not imply that Istation is legally authorized to use any trademark, trade name, logo, or copyright symbol displayed in, or accessible through, such links or that any linked Third-Party Site is authorized to use any trademark, trade name, logo, or copyright symbol of Istation.
2. You may not create an Internet "link" to the Web Site or "frame" or "mirror" any Resource Materials without Istation's prior written permission for each such instance. Additionally, the Web Site may contain links to other pages within the Web Site that are "dead" or that no longer work. Please report any such dead links that You encounter.

3. **Disclaimer.**

1. In purchasing a Subscription to a Purchased Resource, You are being granted access to an interactive Resource for individualized instruction. Given the nature of the Resources, there are many factors outside the reasonable control of Istation that may affect the access to, and use of, the Resources and the Resource Materials, including, but not limited to, failures or difficulties with the Internet or data provided by You. You remain solely responsible for acting or deciding not to act on the results of data input into the Resources and the handling of such results. In providing the Resources, Istation shall not be responsible for loss of data associated with the failure of Your equipment, software, or any information service provider.
2. YOU EXPRESSLY AGREE THAT USE OF THE RESOURCES AND THE RESOURCE MATERIALS (INCLUDING, BUT NOT LIMITED TO, ANY AND ALL FORMS AND FORM LETTERS MADE AVAILABLE BY Istation) IS AT YOUR SOLE RISK. THE RESOURCES AND THE RESOURCE MATERIALS MAY INCLUDE TECHNICAL OR OTHER INACCURACIES OR TYPOGRAPHICAL ERRORS, AND THE RESOURCES AND THE RESOURCE MATERIALS ARE PROVIDED TO YOU ON AN "AS IS," "WHERE IS," AND "WITH ALL FAULTS" BASIS, WITHOUT WARRANTIES OR REPRESENTATIONS OF ANY KIND. THE AFFILIATED GROUP MAKES NO REPRESENTATIONS AND DISCLAIMS ALL EXPRESS AND IMPLIED WARRANTIES AND CONDITIONS OF ANY KIND, INCLUDING, BUT NOT LIMITED TO, REPRESENTATIONS, WARRANTIES, OR CONDITIONS REGARDING ACCURACY, USEFULNESS, TIMELINESS, COMPLETENESS, NONINFRINGEMENT, SATISFACTORY QUALITY, MERCHANTABILITY, QUIET ENJOYMENT, OR THOSE ARISING BY LAW, STATUTE, USAGE OF TRADE, OR COURSE OF DEALING. THE AFFILIATED GROUP AND THE AFFILIATED GROUP'S LICENSORS, SERVICE PROVIDERS, AND SUPPLIERS ASSUME NO RESPONSIBILITY TO YOU OR TO ANY THIRD PARTY FOR THE CONSEQUENCES OF ANY ERRORS OR OMISSIONS OR LACK OF ACCURACY, COMPLETENESS, OR USEFULNESS OF ANY RESOURCES OR RESOURCE MATERIALS. ISTATION RESERVES THE RIGHT, IN ISTATION'S SOLE DISCRETION, TO CORRECT ANY ERRORS OR OMISSIONS IN ANY PORTION OF THE RESOURCE OR THE RESOURCE MATERIALS. Istation MAY MAKE ANY OTHER CHANGES TO THE RESOURCES OR THE RESOURCE MATERIALS AT ANY TIME WITHOUT NOTICE.
3. ISTATION STRIVES TO KEEP THE RESOURCES AND RESOURCE MATERIALS ACCURATE, CURRENT, AND UP TO DATE. HOWEVER, Istation CANNOT GUARANTEE THAT ALL MATERIALS AND ALL RESOURCE MATERIALS (INCLUDING, BUT NOT LIMITED TO, FORMS AND FORM LETTERS) ARE COMPLETELY CURRENT OR STRICTLY COMPLY WITH ALL APPLICABLE LAW, INCLUDING, BUT NOT LIMITED TO, EDUCATIONAL INITIATIVES OR EDUCATIONAL TESTING REQUIREMENTS. THE LAW IS DIFFERENT FROM JURISDICTION TO JURISDICTION AND IS ALSO SUBJECT TO INTERPRETATION BY DIFFERENT COURTS AND OTHER GOVERNING BODIES. THE LAW IS A PERSONAL MATTER, AND NO GENERAL INFORMATION OR TOOLS LIKE THE RESOURCES OR THE RESOURCE MATERIALS CAN FIT EVERY CIRCUMSTANCE. FURTHERMORE, THE INFORMATION CONTAINED ON THE WEB SITE AND IN THE RESOURCES AND RESOURCE MATERIALS IS NOT LEGAL ADVICE AND IS NOT GUARANTEED TO

BE CORRECT, COMPLETE, OR UP TO DATE. THEREFORE, IT IS RECOMMENDED THAT YOU SEEK INDEPENDENT LEGAL ADVICE REGARDING THE SUITABILITY OF THE RESOURCES AND THE RESOURCE MATERIALS.

4. Istation MAKES NO WARRANTY THAT (i) THE RESOURCES OR THE RESOURCE MATERIALS WILL MEET YOUR REQUIREMENTS, (ii) THE RESOURCES OR THE RESOURCE MATERIALS WILL BE AVAILABLE ON AN UNINTERRUPTED, TIMELY, SECURE, OR ERROR-FREE BASIS, (iii) THE RESULTS THAT MAY BE OBTAINED FROM THE USE OF RESOURCES OR RESOURCE MATERIALS WILL BE ACCURATE OR RELIABLE, OR (iv) THE QUALITY OF ANY PRODUCTS, SERVICES, INFORMATION, OR OTHER MATERIALS PURCHASED OR OBTAINED BY YOU AS PART OF THE RESOURCES OR RESOURCE MATERIALS WILL MEET YOUR EXPECTATIONS.
4. **Violations of Terms.** Istation reserves the right to seek all remedies available at law and in equity for violations of these Terms, including, but not limited to, the right to block or restrict access from a particular Internet address to the Web Site.
5. **Miscellaneous.**
 1. You agree to comply with all applicable laws, rules, regulations, orders, and ordinances of the United States of America and in any other state, county, or city with jurisdiction over You or Your activities under these Terms. If any provision of these Terms is held to be illegal, invalid, or unenforceable, then that provision shall be fully severable from these Terms and shall not affect the legality, validity, or enforceability of the remaining provisions of these Terms. Failure of Istation to enforce any of the terms or conditions of these Terms, unless waived in writing, shall not constitute a waiver of Istation's right to enforce each and every term and condition of these Terms. To the extent You have entered into any separate license agreement with Istation for access to, or use of, a Resource (the "**Additional Terms**"), such Additional Terms are incorporated into these Terms by reference. To the extent there is any conflict between these Terms and any Additional Terms, the Additional Terms shall control.
 2. A printed version of these Terms and of any notice given in electronic form shall be admissible in judicial or administrative proceedings based upon, or relating to, these Terms to the same extent and subject to the same conditions as other business documents and records originally generated and maintained in printed form. It is the express wish of Istation and You that these Terms of Use and all related documents be drawn up in English as spoken in the United States.
 3. You may not assign these Terms (or delegate Your rights, duties, or obligations under these Terms) without Istation's prior, express, and written consent.

PRIVACY STATEMENT:

This Privacy Statement is incorporated in, and subject to, the Terms of Use and Service for Imagination Station, Inc. ("**Istation**"). Please refer to those terms for definitions of words with initial capitals letters that are not otherwise defined in this Privacy Statement. Istation encourages you to read this Privacy Statement carefully. For purposes of this Privacy Statement, references to "**You**" or "**Your**" mean (i) you in your individual capacity, (ii) your company, which may be a school or school district, and (iii) students, employees, representatives and agents of Your school or school district that are registered with Istation and that have a valid security identification and password to access and use the Resources (collectively the "**Authorized Users**").

As noted in the Terms of Use, Istation provides its customers with a range of educational resources, including, but not limited to, (i) Istation's interactive educational-based applications (collectively the "**Licensed Applications**"), (ii) Istation's Internet Web site (the "**Web Site**"), currently located at www.istation.com, (iii) account information regarding the Licensed Applications and the Web Site, (iv) materials and documentation (including, but not limited to, preprinted forms, form letters, resource materials, lesson plans, books, images of Istation characters, and so-called "Black Line Masters" coloring-book style pictures) available from the Web Site (collectively the "**Downloadable Materials**"), and (v) news and information about Istation, the Licensed Applications, and the Web Site. Any and all of the foregoing resources (including, but not limited to, the Licensed Applications, the Web Site, and the Downloadable Materials), together with any other resources made available by Istation, are collectively referred to as the "**Resources**".

What Personally Identifiable Information Is Collected by Istation?

"**Personally Identifiable Information**" generally refers to any data that could potentially identify a specific individual. While You have access to the Resources, Istation may collect the following Personally Identifiable Information about You:

- Your first and last name
- **Teachers and administrators only** – Your contact information, such as email addresses, mailing addresses, and phone numbers
- Your school and school district
- Any identification numbers issued by Your school and/or Your school district to You, including teacher numbers, administrator numbers, and student numbers;
- Security information, such as usernames, passwords, and password hints;
- Browser information, such as browser version, IP address, and the presence of various plug-ins and tools;
- **Students only** – "Demographic Data," such as gender, race, special-education status, socio-economic status, and English language learner status, but only to the extent provided by Your school or Your school district;
- Resource-related responses submitted by You, including, but not limited to responses to interactive activities and assessments;
- Resource use behavior, such as pages visited, downloads, or searches requested; and
- Resource use results, but only to the extent that such results identify one or more (i) students, (ii) teachers, (iii) classrooms within an identified school, (iii) grades within an identified school or school district or (iv) schools (collectively "**Identifiable Use Results**"). Identifiable Use Results do not include Resource use results for school districts or for geographic regions that do not identify a specific school (such as Resource use results reported (i) on a county-wide basis, (ii) within a defined territory [whether officially or unofficially defined], such as North Texas, or (iii) within a metropolitan area, such as Dallas-Fort Worth).

Personally Identifiable Information does not include "De-identified Information," which is any data or information that cannot be traced back to an individual (except for Identifiable Use Results, as defined above). For example, a table listing the number of students in each grade at a specific school using a particular Resource would not be Personally Identifiable Information.

How Is Personally Identifiable Information Used and/or Disclosed?

Istation does not sell Personally Identifiable Information to any affiliated entity of Istation or any third-party, nor does it use such information for any sort of behavioral advertising. However, Istation may use and disclose Personally Identifiable Information for a range of educational, compliance and quality assurance purposes.

Istation may use Personally Identifiable Information for the following purposes:

- To provide status reporting notices to teachers and administrators about the Resources (e.g. – an email prompting a teacher to log in to see his or her students' latest assessment results);
- To internally analyze data regarding the use of the Resources;

- To track students' usage of the Resources over time, including performance metrics collected over multiple school years;
- To send You (**teachers and administrators only**) updates, promotional/advertising materials, and newsletters related to the Resources and Istation's products and services or to otherwise market specific Istation services or offers to You. If You want to stop receiving promotional/advertising/marketing materials from Istation, You will have the option to unsubscribe;
- To respond to Your questions or comments; and
- To customize content within the Resources, to improve the Resources' content and functionality and to develop new products and updates.

Istation may disclose Personally Identifiable Information to the following individuals or entities under the following circumstances:

- To Istation's employees who need to access the Personally Identifiable Information to perform their jobs;
- To third parties, including contractors, vendors, and service providers, that assist with the production, implementation or servicing of the Resources, but only after receiving satisfactory assurances from each third-party that its data privacy and security protections are at least as stringent as those of Istation;
- To Authorized Users as determined by each school or school district at issue. Generally, but subject to determination by the school at issue or the school district at issue,
 1. a teacher may only see the Personally Identifiable Information of the students in the teacher's classroom,
 2. a principal may only see the Personally Identifiable Information of those students and teachers in the principal's school, and
 3. a school district-level administrator may only see the Personally Identifiable Information of those students and teachers in the administrator's school district;
- To third parties, and solely for educational purposes, when Istation has the consent of the school or school district at issue, including Identifiable Use Results that identify specific individual students if Istation has received a written acknowledgement from the school or school district that it has obtained the student's consent to such disclosure;
- When Istation believes that sharing Personally Identifiable Information is reasonably necessary in order to (i) protect or defend the legal rights, interests, property, safety, or security of Istation, its employees or contractors, or the public, (ii) protect or defend against, or otherwise address, fraud, security, or technical issues, (iii) comply with, or respond to a law, regulation, legal request, legal process, legal requirement, judicial proceeding, or court order, or (iv) investigate a possible crime, such as fraud or identity theft;
- In connection with an actual or potential sale, purchase, acquisition, merger, reorganization, bankruptcy, liquidation, dissolution, or similar transaction or proceeding of or involving Istation, but only to the extent that the purchasing, acquiring or successor entity agrees to implement data privacy and security protections with respect to Personally Identifiable Information that are at least as stringent as those of Istation.

Istation is permitted to use and/or disclose Personally Identifiable Information about You when Istation has Your consent. Istation does not need Your consent to use De-identified Information.

Can I Access or Change My Personally Identifiable Information?

Each school and/or school district is permitted via functionality made available by the Resources to determine what Personally Identifiable Information (if any) is accessible by Authorized Users and to which Authorized Users in particular. In certain circumstances, a school and/or school district may be entitled to permit one or more Authorized Users to change Personally Identifiable Information. Any requests by Students or parents to access and/or change Personally Identifiable Information must be made to the school and/or school district in the first instance, and these entities will maintain a record of all such access and amendment requests and of any actual changes made. To the extent that a student and/or parent makes a direct request to Istation to access and/or amend Personally Identifiable Information, Istation will forward that request to the school and/or school district for response.

Data Retention

Unless required by law to maintain certain information for a longer period of time, Istation retains Personally Identifiable Information only for as long as a student's school and/or school district maintains a subscription with Istation to one or more of the Resources. Once a subscription to a particular Resource is cancelled or otherwise terminated, Istation will typically retain any Personally Identifiable Information related to that Resource for sixty days after cancellation/termination to allow for temporary lapses in subscription services, at which point that information is destroyed. Personally Identifiable Information may also be destroyed at any time at the request of the school and/or school district.

Website and Resource Security

Istation recognizes its responsibility to protect the Personally Identifiable Information that You entrust to it. Istation uses a variety of secure techniques to protect Your information, including secure servers, firewalls, access limitations on Istation's servers and password protections that guard against unauthorized access. Additionally, the information that You send Istation via the Website, including student usage information and passwords, may be encrypted, a process used to scramble information and make it extremely difficult to read if wrongly intercepted. Istation utilizes industry standard Secure Sockets Layer (SSL) technology to allow for the encryption of Personally Identifiable Information. All Personally Identifiable Information sent to Istation is encrypted during transmission, such as during login. Once the data reaches Istation's server, Personally Identifiable Information is stored on a secure database, and access to this information is password protected.

Use of "Cookies"

"Cookies" are small pieces of information that some websites store on Your computer's hard drive when You visit them. This element of data is a piece of text, not a program, that contains information identifying a user. When a user revisits a Website, his or her computer automatically "serves up" the cookie, eliminating the need for the customer to reenter the information. Like many other websites, Istation uses cookies for this purpose. Your user "domain" (that is, Your school name) is the only data stored on Your hard drive by Istation.

Most web browsers automatically accept cookies but allow You to modify security settings so You can approve or reject cookies on a case-by-case basis. At a minimum, Your web browser must allow temporary cookies that are not stored on Your hard disk to log into the Website. Please refer to the "Help" file of Your Internet Browser either to learn how to receive a warning before a cookie is stored.

Third Party Sites

The Website may contain links to or reference third party websites and resources (collectively "**Third Party Sites**"). These Third Party Sites are not controlled by Istation and, therefore, are not subject to this Privacy Statement. You should check the privacy policies of these individual Third Party Sites to see how Your personally identifiable information will be utilized by them before providing any personally identifiable information. Please be aware that these Third Party Sites may collect personally identifiable information about You and may also send you "cookies." Istation is not responsible for the content or practices of any linked Third Party Sites, and Istation provides these links solely for the convenience and information of Istation's visitors.

Can Istation change this Privacy Statement?

Istation may change this Privacy Statement at any time without advance notice. However, if the Privacy Statement changes, Istation will post an updated version on the Website, and the revision date will be posted at the bottom of the page. If this occurs, You will be required to re-acknowledge review of the revised Privacy Statement before you can continue using the Resources.

Who can I contact if I have questions about this Privacy Statement?

If You have any questions about this Privacy Statement or any privacy questions or concerns, You may contact Istation using the information below:

Email address: info@Istation.com

Street/Postal address:

8150 North Central Expressway, Suite 2000
Dallas, Texas 75026

Phone: (214) 237-9300

Fax: (972) 643-3441

Effective Date: February 23, 2018

Copyright

Copyright © 1998-2020 Istation.com
Imagination Station, Inc. DBA Istation
8150 North Central Expressway, Suite 2000
Dallas, TX 75206
All rights reserved.

Trademarks

The Imagination Station DBA Istation, Istation.com, Infinity, and other Istation.com programs, products, and technology referenced herein are either registered trademarks or trademarks of Istation.com in the U.S. and/or other countries. The names of actual companies and products mentioned herein may be the trademarks of their respective owners.

Any rights not expressly granted herein are reserved.

SANTA CRUZ CITY SCHOOL DISTRICT

AGENDA ITEM: Memorandums of Understanding: Special Education: SAIL

MEETING DATE: August 17, 2022

FROM: Dorothy Coito, Assistant Superintendent of Educational Services

THROUGH: Kris Munro, Superintendent

RECOMMENDATION:

Approve the MOUs listed below so that Santa Cruz City Schools can serve students from neighboring districts.

BACKGROUND:

Santa Cruz City Schools (SCCS) is the largest district in our Special Education Local Planning Area (SELPA). As such, SCCS provides the largest continuum of services for special education students in our SELPA. On occasion, neighboring districts may seek to have their students served in SCCS programs because they do not have appropriate programs available in their home district. In these instances, SCCS may enter into an agreement whereby SCCS accepts an out of district student into a special education program at one of our schools and then charges the neighboring district for such services.

Following is a list of MOUs proposed for the 2022-23 school year. These placements may last a full year or may end prior to the end of school because a student is successfully able to re-integrate into a program within their home district. As well, new students may enroll following the date of this board meeting due to previously unidentified needs.

<u>District</u>	<u>District</u>	<u>Number of Students</u>
Live Oak School District	Elementary/Secondary	3
San Lorenzo Valley USD	Elementary/Secondary	5
Scotts Valley USD	Elementary/Secondary	11
Soquel USD	Secondary	1
Pajaro Valley USD	Secondary	1

FISCAL IMPACT:

This work will generate revenue to the district, covering the cost of the pupils enrolled in our programs from the sending school district.

This work is in direct support of the following District goals and their corresponding metrics

AGENDA ITEM: 8.2.1.5.

Goal #1: All Santa Cruz City Schools students will be prepared to successfully access post-secondary college and career opportunities.

Goal #5: SCCS will maintain a balanced budget and efficient and effective management.

Goal #6: SCCS will maintain strong communication and partnership with its diverse community.

Prepared by Stacy O'Farrell, Director of Special Education

SANTA CRUZ CITY SCHOOL DISTRICT

AGENDA ITEM: Benchmark Books

MEETING DATE: August 17, 2022

FROM: Dorothy Coito, Assistant Superintendent of Educational Services

THROUGH: Kris Munro, Superintendent

RECOMMENDATION:

Ratify the agreement with Benchmark Education to purchase Phonics Intervention curriculum for SCCS Elementary.

BACKGROUND:

Benchmark Phonics Intervention Curriculum will be used by Response to Intervention staff and Special Education Resource Specialists to give Tier 2 and Tier 3 support to students who are struggling with phonics.

The books needed to be purchased during the summer due to Response to Intervention team and Special Education Resources Specialists attending a training on the curriculum on August 18, 2022.

FISCAL IMPACT:

\$42,472.08 LCFF Base (Unrestricted)

This work is in direct support of the following District goals and their corresponding metrics:

Goal #3: We will eliminate the achievement gaps that currently exist between demographic groups within the SCCS student community.

Goal #4 We will develop a highly collaborative, professional culture focused on supporting effective teaching.



**BENCHMARK
EDUCATION
COMPANY**
145 Huguenot Street, 8th Floor
New Rochelle, New York 10801

Contact representative
Michele VanHentenryck
Email: mvanhentenryck@benchmarkeducation.com
Office Phone: (831) 252-2535
Phone: (831) 252-2535

QUOTE: 36980

Customer:
ACCOUNTS PAYABLE
BUSINESS DEPARTMENT
133 Mission St Ste 100
Santa Cruz CA 95060-3747
United States

Ship To:
ACCOUNTS PAYABLE
BUSINESS DEPARTMENT
133 Mission St Ste 100
Santa Cruz CA 95060-3747

Product Code	Title	Price Level	Unit Price	Qty	Total Price
Y50967	Phonics Intervention Level 1 Teacher Print Package	Current	\$1,106.00	13	\$14,378.00
Y50968	Phonics Intervention Level 2 Teacher Print Package	Current	\$1,106.00	13	\$14,378.00
Y50969D	Phonics Intervention Level 3 Teacher Print Package	Current	\$1,106.00	5	\$5,530.00
Y50971	Phonics Intervention Level 1 Student Print Package Consumables 1-Year	Current	\$70.00	5	\$350.00
Y50972	Phonics Intervention Level 2 Student Print Package Consumables 1-Year	Current	\$70.00	9	\$630.00
Y50973	Phonics Intervention Level 3 Student Print Package Consumables 1-Year	Current	\$70.00	5	\$350.00

Subtotal	Sales Tax	Shipping Cost	Total
\$35,616.00	\$3,294.48	\$3,561.60	\$42,472.08 USD

Memo

- * The above pricing cannot be combined with any other offers.
- * Price firm for 45 days from quote date. Price quote must be attached to school purchase orders to receive the quoted price.
- * All digital subscriptions will end on July 31st the last year of the term purchased.
- * Trainings must be cancelled before scheduled training date (at least five (5) business days prior for on-site and at least 72 hours prior for virtual trainings). If you cancel trainings after these periods, you will be charged the full amount of the training session(s) cancelled.

01-0000-0-1110-1000-4100-520-CMP1



**BENCHMARK
EDUCATION
COMPANY**
145 Huguenot Street, 8th Floor
New Rochelle, New York 10801

Contact representative
Michele VanHentenryck
Email: mvanhentenryck@benchmarkeducation.com
Office Phone: (831) 252-2535
Phone: (831) 252-2535

QUOTE: 36980

PLEASE INCLUDE THIS PROPOSAL WITH YOUR PURCHASE ORDER ALONG WITH THE FOLLOWING INFORMATION FOR ALL DIGITAL SUBSCRIPTIONS

• Name of School(s) That Will Use the Subscription(s)
Attach separate document if necessary

• Onboarding Tech Contact Name

• Onboarding Tech Contact E-Mail

• REQUIRED

SEND ORDER TO: Benchmark Education Company
6295 Commerce Center Drive, Suite B| Groveport, OH 43125-1160
Email: neworders@benchmarkeducation.com
Phone: 877-236-2465| Fax: 877-732-8273

Terms of Service

* By placing an order for Benchmark Education Company ("BEC") products (the "Products"), the entity ("Customer") that this proposal has been prepared for agrees to be bound by BEC's Terms of Service and Terms of Use and Privacy Policy (see below). Subject to the Customer's payment of the fees set out above, BEC grants to Customer a non-exclusive and non-transferable license to access and use the Products under the terms described in this Terms of Service. The proposal contains the scope of use allowed and the term of Customer's license to the Products.

SANTA CRUZ CITY SCHOOL DISTRICT

AGENDA ITEM: Lexia English Professional Development

MEETING DATE: August 17, 2022

FROM: Dorothy Coito, Assistant Superintendent of Educational Services

THROUGH: Kris Munro, Superintendent

RECOMMENDATION:

Ratify the agreement with Lexia Learning Systems to provide a full day of professional learning to elementary teachers.

BACKGROUND:

Lexia English is a program designed to support English Learners with Designated English Language Development in listening and speaking. The program is online and self-paced, with related lessons that are delivered by the English Language Development teachers. The program is meant to integrate with Lexia Core5 Reading to deliver results for improving English Learner proficiency. All elementary English Learners will have access to this program.

Because the program is new, training was needed for all elementary teachers at the Professional Development Day on August 5, 2022. Staff were not able to finalize this contract prior to the last June Board meeting. The Professional Learning Day was an in-person training and all TK-5th grade teachers were trained on how to use the program. There will be follow up professional development in the coming months.

FISCAL IMPACT:

\$4,250 Title IV (Restricted)

This work is in direct support of the following District goals and their corresponding metrics:

Goal #3: We will eliminate the achievement gaps that currently exist between demographic groups within the SCCS student community.

Goal #4 We will develop a highly collaborative, professional culture focused on supporting effective teaching.

QUOTE



Lexia Learning Systems LLC

300 Baker Avenue, Suite 320
Concord, MA 01742 USA
Phone: (978) 405-6200
Fax: (978) 287-0062

Quote #: Q-518707-2
Created Date: 7/13/2022

Prepared By: Katie Kennelly
Email: katie.kennelly@lexialearning.com

Quote To:
Santa Cruz City School District
405 San Jose Road
Soquel, CA 95073 US

Bill To:
Shannon Calden
Santa Cruz City School District
ATTN: Accounts Payable
133 Mission St Ste 100
Santa Cruz, CA 95060 US

Start Date	End Date	Quantity	Line Item Description	Sales Price	Total Price
8/1/2022	7/31/2023	1	Lexia English Professional Learning Day - Full	\$4,250.00	\$4,250.00

Total Price \$4,250.00

Fax or email Purchase Orders with quote number Q-518707-2 to the following:

Attn: Katie Kennelly
Email: katie.kennelly@lexialearning.com
Fax: (978) 402-3621

PLEASE NOTE THE QUOTE NUMBER MUST APPEAR ON PURCHASE ORDER(S) IN ORDER TO PROCESS.

TERMS AND CONDITIONS

**Prices included herein are exclusive of all applicable taxes, including sales tax, VAT or other duties or levies imposed by any federal, state or local authority, which are the responsibility of Customer. Any taxes shown are estimates for informational purposes only. Customer will provide documentation in support of tax exempt status upon request. Pricing is valid 60 days. Lexia will invoice the total price set forth above upon Customer's acceptance. Payment is due net 30 days of invoice.

TERM

This quote serves as an Order Agreement and becomes effective upon its acceptance by both parties. The Product/Services purchased pursuant to this Agreement will begin on or about the start date set forth above and continue in effect for the Product/Service Term set forth above ("Subscription Period"). Unless otherwise set forth herein, all Product licenses shall have the same start and end dates, all Products are deemed delivered upon provisioning of license availability, and all Services must be used within the Subscription Period; unused Product licenses or Services are not eligible for refund or credit. Onsite training fulfilled with virtual training equivalency as needed. Virtual training equivalency = four (4) live online sessions for each onsite training day session. Without prejudice to its other rights, Lexia may suspend delivery of the Product/Services in the event that Customer fails to make any payment when due.

ORDER PROCESS

To submit an order, please fax this quote along with the applicable Purchase Order to: (978) 287-0062, or send by email to your sales representative's email address listed above.

NOTE: EACH PURCHASE ORDER MUST INCLUDE THE CORRECT QUOTE NUMBER PROVIDED ON THIS QUOTE, AND THE QUOTE SHOULD BE ATTACHED.

ACCEPTANCE

All Products and Services are offered subject to the Lexia K-12 Education Application License Agreement terms, available at <https://lexialearning.com/privacy/eula> (the "License"), as supplemented by the terms herein. By placing any order in response to this quote, Customer confirms its acceptance of the License Terms and the terms and fees in this quote, which together, constitute the entire agreement between Customer and Lexia regarding the Products and Services herein (the "Agreement"). Customer and Lexia agree that the terms and conditions of this Agreement supersede any additional or inconsistent terms or provisions in any Customer drafted purchase order, which shall be void and of no effect, or any communications, whether written or oral, between Customer and Lexia relating to the subject matter hereof. In the event of any conflict, the terms of this Agreement shall govern.

SANTA CRUZ CITY SCHOOL DISTRICT

AGENDA ITEM: Laptop Purchase

MEETING DATE: August 17, 2022

FROM: Dorothy Coito, Assistant Superintendent of Educational Services

THROUGH: Kris Munro, Superintendent

RECOMMENDATION:

Approve the purchase of 50 laptops for teachers across all sites.

BACKGROUND:

Current industry standards allow for a 3 to 5-year life cycle for standard laptops that fit most faculty needs. With about 700 laptops in circulation, the range for laptops that could reach end-of-life is 140-233 laptops each school year. Currently, SCCS has immediate laptop needs for approximately 70 teachers and staff. Over the course of the school year, staff anticipate other laptops reaching end-of-life and needing to be replaced.

To address this expected need, staff are reassigning laptops that were purchased for Career Technical Education programs two years ago. Staff have identified 55 of these laptops that can be refreshed and reassigned to faculty whose laptop has reached end-of-life. Additionally, SCCS needs to purchase 50 laptops so that teachers are properly equipped to start the school year. That leaves the district with 35 laptops (5% of 700) for any replenishments over the next few months.

FISCAL IMPACT:

\$45,485.22 total CRF COVID (Restricted)
\$15,919.83 Elementary
\$29,565.39 Secondary

This work is in direct support of the following District goals and their corresponding metrics:

Goal #4: We will develop a highly collaborative, professional culture focused on supporting effective teaching.

Goal #5: SCCS will maintain a balanced budget and efficient and effective management.

AGENDA ITEM: 8.2.1.8.

QUOTE CONFIRMATION



DEAR SCCS WAREHOUSE,

Thank you for considering CDW•G LLC for your computing needs. The details of your quote are below. [Click here](#) to convert your quote to an order.

QUOTE #	QUOTE DATE	QUOTE REFERENCE	CUSTOMER #	GRAND TOTAL
1C8F3X3	8/4/2022	50 STAFF LAPTOP	1165316	\$45,485.22

IMPORTANT - PLEASE READ
Fees applied to item(s): 6730142

QUOTE DETAILS				
ITEM	QTY	CDW#	UNIT PRICE	EXT. PRICE
Lenovo ThinkBook 14 G2 ITL - 14" - Core i5 1135G7 - 16 GB RAM - 256 GB SSD Mfg. Part#: 20VD016KUS Contract: Sourcewell 081419-CDW Tech Catalog (081419#CDW)	50	6730142	\$829.02	\$41,451.00
RECYCLING FEE DETAILS				
ITEM	QTY	CDW#	UNIT PRICE	EXT. PRICE
RECYCLING FEE 4" TO LESS THAN 15" Fee Applied to Item: 6730142	50	654809	\$4.00	\$200.00

PURCHASER BILLING INFO	SUBTOTAL	\$41,451.00
Billing Address: SANTA CRUZ CITY SCHOOLS ACCOUNTS PAYABLE 133 MISSION ST STE 100 SANTA CRUZ, CA 95060-3747 Phone: (831) 429-3410 Payment Terms:	SHIPPING	\$0.00
	RECYCLING FEE	\$200.00
	SALES TAX	\$3,834.22
	GRAND TOTAL	\$45,485.22
DELIVER TO	Please remit payments to:	
Shipping Address: SANTA CRUZ CITY SCHOOLS ATTN:SCCS WAREHOUSE 536 PALM ST SANTA CRUZ, CA 95060-4758 Phone: (831) 429-3410 Shipping Method: DROP SHIP-GROUND	CDW Government 75 Remittance Drive Suite 1515 Chicago, IL 60675-1515	

Need Assistance? CDW•G LLC SALES CONTACT INFORMATION		
	Chris Atraje (877) 325-2820	chriatr@cdwg.com

This quote is subject to CDW's Terms and Conditions of Sales and Service Projects at <http://www.cdwg.com/content/terms-conditions/product-sales.aspx>
 For more information, contact a CDW account manager
 © 2022 CDW•G LLC 200 N. Milwaukee Avenue, Vernon Hills, IL 60061 | 800.808.4239

SANTA CRUZ CITY SCHOOL DISTRICT

AGENDA ITEM: Chromebook Purchase - Soquel and Santa Cruz High

MEETING DATE: August 17, 2022

FROM: Dorothy Coito, Assistant Superintendent of Educational Services

THROUGH: Kris Munro, Superintendent

RECOMMENDATION:

Approve the purchase of 600 Chromebooks for deployment at Soquel High School and Santa Cruz High School.

BACKGROUND:

At the end of the 21-22 school year, each site worked to retrieve Chromebooks that were checked out during distance and hybrid learning. Due to loss, damage as well as the number of devices that are at “end of life,” three SCCS high schools now average less than one device per student. Between Soquel and Santa Cruz High, we are short 600 Chromebooks.

At full capacity, Chromebook carts can be loaded with 36 Chromebooks. Each school allocates these carts appropriately to each department. For instance, Soquel currently has the equivalent of 22 full carts. However, some departments share less than half the number of carts as teachers. This purchase will bring 6-10 full carts to both Soquel and Santa Cruz High, aligning our numbers closer to a 1:1 device per student.

SCCS currently is in the second year of a four-year cooperative purchasing agreement with Sourcewell (via CDW Government). Chromebook Replacements were originally budgeted for \$240,000. The increase to \$264,735 is attributed to 10% higher unit costs than last year.

FISCAL IMPACT:

\$ 264,735 LCFF Base (Unrestricted)

This work is in direct support of the following District goals and their corresponding metrics:

Goal #1: All Santa Cruz City Schools students will be prepared to successfully access post-secondary college and career opportunities.

Goal #3: We will eliminate the achievement gaps that currently exist between demographic groups within the SCCS student community.

Goal #4: We will develop a highly collaborative, professional culture focused on supporting effective teaching.

AGENDA ITEM: 8.2.1.9.



QUOTE CONFIRMATION

CURTIS GOMEZ,

Thank you for considering CDW•G for your computing needs. The details of your quote are below. [Click here](#) to convert your quote to an order.

Convert Quote to Order

QUOTE #	QUOTE DATE	QUOTE REFERENCE	CUSTOMER #	GRAND TOTAL
MWGP149	7/15/2022	MWGP149	1165316	\$264,735.00

IMPORTANT - PLEASE READ

Fees applied to item(s): 6636401

QUOTE DETAILS

ITEM	QTY	CDW#	UNIT PRICE	EXT. PRICE
HP Chromebook 14 G7 - 14" - Celeron N4500 - 8 GB RAM - 32 GB eMMC - US Mfg. Part#: 3V2T8UT#ABA Contract: Sourcewell# 081419 Tech Catalog- (Chromebook ONLY) (081419-CDW)	600	6636401	\$370.00	\$222,000.00
Google Chrome Education Upgrade Mfg. Part#: CROS-SW-DIS-EDU-NEW Electronic distribution - NO MEDIA Contract: Sourcewell# 081419 Tech Catalog- (Chromebook ONLY) (081419-CDW)	600	5988499	\$33.00	\$19,800.00

RECYCLING FEE DETAILS

ITEM	QTY	CDW#	UNIT PRICE	EXT. PRICE
RECYCLING FEE 4" TO LESS THAN 15" Fee Applied to Item: 6636401	600	654809	\$4.00	\$2,400.00

SUBTOTAL	\$241,800.00
SHIPPING	\$0.00
RECYCLING FEE	\$2,400.00
SALES TAX	\$20,535.00
GRAND TOTAL	\$264,735.00

PURCHASER BILLING INFO	DELIVER TO
Billing Address: SANTA CRUZ CITY SCHOOLS ACCOUNTS PAYABLE 133 MISSION ST STE 100 SANTA CRUZ, CA 95060-3747 Phone: (831) 429-3410 Payment Terms: NET 30 Days-Govt/Ed	Shipping Address: SANTA CRUZ CITY SCHOOLS CURTIS GOMEZ 133 MISSION ST STE 100 SANTA CRUZ, CA 95060-3747 Phone: (831) 429-3410 Shipping Method: UPS Freight LTL, Dock to Dock
	Please remit payments to: CDW Government 75 Remittance Drive Suite 1515 Chicago, IL 60675-1515



Sales Contact Info

Chris Atraje | (877) 325-2820 | chriatr@cdwg.com

LEASE OPTIONS			
FMV TOTAL	FMV LEASE OPTION	BO TOTAL	BO LEASE OPTION
\$244,200.00	\$6,481.07/Month	\$244,200.00	\$7,504.27/Month

Monthly payment based on 36 month lease. Other terms and options are available. Contact your Account Manager for details. Payment quoted is subject to change.

Why finance?

- Lower Upfront Costs. Get the products you need without impacting cash flow. Preserve your working capital and existing credit line.
- Flexible Payment Terms. 100% financing with no money down, payment deferrals and payment schedules that match your company's business cycles.
- Predictable, Low Monthly Payments. Pay over time. Lease payments are fixed and can be tailored to your budget levels or revenue streams.
- Technology Refresh. Keep current technology with minimal financial impact or risk. Add-on or upgrade during the lease term and choose to return or purchase the equipment at end of lease.
- Bundle Costs. You can combine hardware, software, and services into a single transaction and pay for your software licenses over time! We know your challenges and understand the need for flexibility.

General Terms and Conditions:

This quote is not legally binding and is for discussion purposes only. The rates are estimate only and are based on a collection of industry data from numerous sources. All rates and financial quotes are subject to final review, approval, and documentation by our leasing partners. Payments above exclude all applicable taxes. Financing is subject to credit approval and review of final equipment and services configuration. Fair Market Value leases are structured with the assumption that the equipment has a residual value at the end of the lease term.

Need Help?



My Account



Support



Call 800.800.4239

[About Us](#) | [Privacy Policy](#) | [Terms and Conditions](#)

This order is subject to CDW's Terms and Conditions of Sales and Service Projects at <http://www.cdwg.com/content/terms-conditions/product-sales.aspx>

For more information, contact a CDW account manager

© 2022 CDW•G LLC, 200 N. Milwaukee Avenue, Vernon Hills, IL 60061 | 800.808.4239

SANTA CRUZ CITY SCHOOL DISTRICT

AGENDA ITEM: Keenan: Excess Cyber Liability Proposal

MEETING DATE: August 17, 2022

FROM: Jim Monreal, Assistant Superintendent Business Services

THROUGH: Kris Munro, Superintendent

RECOMMENDATION:

Ratify Keenan’s Santa Cruz City Schools Excess Cyber Liability Proposal for the 2022/2023 school year.

BACKGROUND:

This proposal consists of coverage and premium for Optional Excess Cyber Safety Insurance Coverage services. In 2021-22, the coverage was purchased by our insurance Joint Powers Authority. For 2022-23, the coverage is not being offered to our Joint Powers Authority. Instead, it is being offered individually to each district in the Insurance Joint Powers Authority. This will provide excess coverage to SCCS, helping the District be prepared to offset challenges and fiscal coverage in the event of an information system attack in 2022-23. This coverage was strongly recommended by our insurance company as other districts’ have had their information systems compromised, holding the information system for ransom impacting all district functions.

FISCAL IMPACT:

\$36,138 LCFF Base (Unrestricted)

This work is in direct support of the following District goals and their corresponding metrics:

- Goal #2: SCCS will create positive, engaging school environments that promote the development of cognitive skills and the social emotional well-being of all students.
- Goal #5: SCCS will maintain a balanced budget and efficient and effective management.
- Goal #6: SCCS will maintain strong communication and partnership with its diverse community.



Santa Cruz City Schools
Excess Cyber Liability
2022/2023 Proposal

Santa Cruz City Schools
Excess Cyber Proposal

CARRIER	Obsidian Specialty Insurance Company (via Cowbell)
AM Best Rating	A- (Superior)
California Status	Financial Size Category VII (\$50 million to \$100 million) Non-admitted
COVERAGE	Prime Plus Excess Cyber Insurance (Follow Form)
POLICY TERM	July 1, 2022 to July 1, 2023
TIER	2 (Non-Compliant)
AVERAGE DAILY ATTENDANCE	6,777
REVENUE	\$120,493,524.62
LIMITS OF LIABILITY	\$1,000,000 aggregate
Incident Response	\$1,000,000
Direct Network Interruption/Business Income	\$1,000,000
Contingent Network Interruption/Business Income	\$1,000,000
Bricking	\$250,000
Reputational Business Income	\$1,000,000
Cyber Extortion and Ransom	\$250,000 (subject to 25% coinsurance)
Privacy Regulatory Defense and Penalties	\$1,000,000
PCI Expenses and Penalties	\$250,000
Privacy and Network Security Liability	\$1,000,000
RETENTION	\$50,000 K12s with less than 9K avg daily attendance
MAJOR EXCLUSIONS	Follows underlying, plus: Pending or Prior Suits
ANNUAL PREMIUM	\$35,000
Surplus Lines Taxes and Fees (3.25%)	\$1,137.50
Total Cost	\$36,137.50
COMMISSION	10.5%
FORMS ATTACHED AT INCEPTION	<ul style="list-style-type: none"> • Prime Plus 100 1020 Prime Plus Excess Cyber Insurance Policy • Prime Plus 101 1020 Prime Plus Excess Cyber Insurance Policy Declarations • PN007 Plus 0920 Customer Notice of Privacy Policy And Producer Compensation Practices Disclosure • PN006 Plus 0920 Notice to Policyholders U.S. Treasury Department's Office of Foreign Assets Control (OFAC) • Prime Plus 029 10 20 Cap on Losses from Certified Acts of Terrorism • Prime Plus 102 1020 Drop Down Endorsement • Prime Plus 105 1020 Specific Individual/Entity Exclusion Endorsement • Prime Plus 107 1020 Pending or Prior Exclusion Endorsement • Prime Plus 117 1020 Non-Follow Form Endorsement • Prime Plus 075 12 20 Service of Process Endorsement

WARRANTY STATEMENT OF NO KNOWN OR REPORTED LOSSES, CLAIMS, LAWSUITS OR OCCURRENCES

I/we have no knowledge of any losses, claims, lawsuits, or occurrences that have taken place or were first reported that will result in the submission of a claim to the Company.

I/we acknowledge that the Company is relying on this Warranty Statement in providing coverage.

I have no knowledge of any loss or damage that has occurred for which coverage might be claimed under my policy, number from the date of up to a.m./p.m. on. I have personal knowledge about the occurrences that could form the basis of a claim under the referenced insurance policy. In addition, I have made a diligent inquiry among all other persons insured by the policy to confirm the lack of any potential occurrence that could trigger an insurance claim before signing this Statement.

I agree that if any of the foregoing statements are untrue, in whole or in part, and a loss has occurred for which coverage might be claimed under the above policy during the time period stated above, the policy is and will be considered VOID in its entirety. I further agree that in such event, no coverage exists under the above policy for any such loss or damage. If the insurance company becomes obligated to pay defense costs, fees, or expenses or make any payment under the policy for any such loss or damage, the insurance company may seek reimbursement from me, and I agree to reimburse the insurance company for such defense costs, fees, or expenses.

It is further agreed that in the event such loss or damage has occurred, whether or not disclosed herein, no coverage will be afforded for such loss or damage under the policy.

Upon signing and accepting this Warranty of No Loss, I hereby acknowledge and agree that the insurance company is relying upon this Warranty and the truth of the statements, warranties, guarantees, and agreements made herein as an inducement to and in consideration for the reinstatement of the above policy.

It is agreed that in the event any term or provision of this Warranty is held by a court of competent jurisdiction to be invalid, void, or unenforceable, the remainder of the provisions of this Warranty shall remain in full force and effect and shall in no way be affected, impaired, or invalidated.

Jimmy Montreal

Signed by (Printed Name)

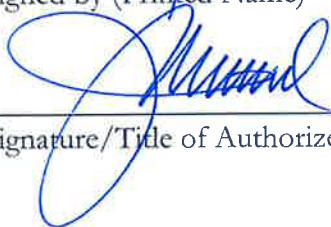

Signature/Title of Authorized Representative

Asst Supt / Bus Serv

Title

07/07/22

Date

DISCLOSURE STATEMENT

AssuredPartners agencies are licensed as insurance producers by the various States where we are transacting insurance, which includes the sale, solicitation, and servicing of insurance business, as well as advising on the relative benefits of certain insurance policies and risk management programs. Our agencies typically receive compensation from insurers in the form of commissions paid as a percentage of the premiums due the applicable insurance companies. Commissions can vary by insurance company, by volume of business placed with that company or the profitability thereof, and other factors. In other cases, depending on various State laws and the capacity in which our agency is acting, our agencies may receive other forms of compensation from insurers, insurance intermediaries, premium finance companies and other vendors; such as contingents, overrides, profit-sharing, premium finance fees, expense reimbursements, producer subsidies, award trips, meetings, and other incentives. We also earn interest on premiums we hold until it is time to pay the applicable insurance companies.

Our overriding desire is to provide great customer service, having you, the customer, believe we have earned our compensation. We believe in full disclosure of our compensation. Accordingly, if you have any questions about the compensation we receive from your policies (including policies we propose to you), please just ask your account representative, who will gladly provide you a summary of our compensation arising from your policies (some estimation may be necessary, for example where contingents are involved).

This proposal provides a summary of coverages. In the event of a conflict, the actual terms, conditions, limitations, and exclusions of the policy shall prevail.

I have reviewed and accept the attached Cyber Liability Proposal. Please accept this as our authorization to bind coverage **effective July 1, 2022** per the terms and conditions detailed in this proposal for:

Jimmy Montreal
Signed by (Printed Name)

Anti Supt / Bus Service
Title

[Signature]
Signature/ Title of Authorized Representative

07/07/22
Date

IMPORTANT NOTICE:

- 1. The insurance policy that you are applying to purchase is being issued by an insurer that is not licensed by the State of California. These companies are called “nonadmitted” or “surplus line” insurers.**
- 2. The insurer is not subject to the financial solvency regulation and enforcement that apply to California licensed insurers.**
- 3. The insurer does not participate in any of the insurance guarantee funds created by California law. Therefore, these funds will not pay your claims or protect your assets if the insurer becomes insolvent and is unable to make payments as promised.**
- 4. The insurer should be licensed either as a foreign insurer in another state in the United States or as a non-United States (alien) insurer. You should ask questions of your insurance agent, broker, or “surplus line” broker or contact the California Department of Insurance at the toll-free number 1-800-927-4357 or internet website www.insurance.ca.gov. Ask whether or not the insurer is licensed as a foreign or non-United States (alien) insurer and for additional information about the insurer. You may also visit the NAIC’s internet website at www.naic.org. The NAIC—the National Association of Insurance Commissioners—is the regulatory support organization created and governed by the chief insurance regulators in the United States.**
- 5. Foreign insurers should be licensed by a state in the United States and you may contact that state’s department of insurance to obtain more information about that insurer. You can find a link to each state from this NAIC internet website: https://naic.org/state_web_map.htm.**

6. For non-United States (alien) insurers, the insurer should be licensed by a country outside of the United States and should be on the NAIC's International Insurers Department (IID) listing of approved nonadmitted non-United States insurers. Ask your agent, broker, or "surplus line" broker to obtain more information about that insurer.

7. California maintains a "List of Approved Surplus Line Insurers (LASLI)." Ask your agent or broker if the insurer is on that list, or view that list at the internet website of the California Department of Insurance: www.insurance.ca.gov/01-consumers/120-company/07-lasli/lasli.cfm.

8. If you, as the applicant, required that the insurance policy you have purchased be effective immediately, either because existing coverage was going to lapse within two business days or because you were required to have coverage within two business days, and you did not receive this disclosure form and a request for your signature until after coverage became effective, you have the right to cancel this policy within five days of receiving this disclosure. If you cancel coverage, the premium will be prorated and any broker's fee charged for this insurance will be returned to you.

Date: 07/07/22

Insured: 

D-1 (Effective January 1, 2020)

SANTA CRUZ CITY SCHOOL DISTRICT

AGENDA ITEM: Food Service Agreement with Pacific Collegiate School

MEETING DATE: August 17, 2022

FROM: Jim Monreal, Assistant Superintendent of Business Services

THROUGH: Kris Munro, Superintendent

RECOMMENDATION:

Approve the interagency agreement between Santa Cruz City Schools Food Services Department and Pacific Collegiate School.

BACKGROUND:

The Santa Cruz City Schools Food Service Department will prepare meals for Pacific Collegiate School. These meals will meet or exceed the National School Lunch Program requirements. This agreement will provide revenue for the Food Services program.

FISCAL IMPACT:

\$171,000 yearly revenue

This work is in direct support of the following District goals and their corresponding metrics:

- Goal #2: SCCS will create positive, engaging school environments that promote the development of cognitive skills and the social emotional well-being of all students.
- Goal #5: SCCS will maintain a balanced budget and efficient and effective management.
- Goal #6: SCCS will maintain strong communication and partnership with its diverse community.

SANTA CRUZ CITY SCHOOLS
133 Mission Street Ste. 100
Santa Cruz Ca. 95062
831-429-3410

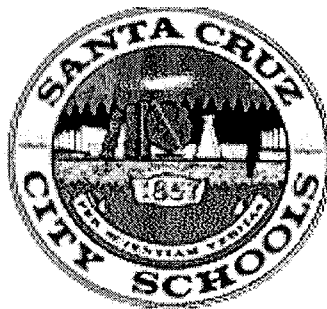

FOOD SERVICES DEPARTMENT
310 LA FONDA AVE
SANTA CRUZ CA 95062
831-429-3850
fax: 831-429-3849

This interagency agreement entered into July 1, 2022, by and between Santa Cruz City Schools Food Services Department, hereafter referred to as "SCCS" and Pacific Collegiate School, hereafter referred to as "PCS" is made for the purpose to vend meals which meet or exceed the National School Lunch Program meal requirements for the COE's Alternative Education Programs.

It is hereby agreed that:

1. SCCS shall prepare meals that meet or exceed the National School Lunch Program meal requirements, maintaining temperature and quality of meals for and until receipt by PCS staff. Breakfast & lunch must comply with the nutritional standards for meals as established by the USDA and CDE.
2. SCCS shall and will provide the necessary utensils, serving materials, trays and napkins. SCCS will provide transportation and time / temperature logs to PCS.
3. SCCS shall provide the number of lunches requested each school day that PCS is in session. If scheduling conflicts based on differing school calendars shall occur, SCCS will make arrangements to ensure qualified reimbursable meals are provided.
4. The number of breakfast & lunches prepared by SCCS shall be equal to the number of meals requested by PCS.
5. PCS shall notify SCCS no later than 2pm two day's prior of the number of meals required for service. Change notifications must be communicated to the Central Kitchen at (831)429-3810.
6. PCS will be obligated to accept and pay for the number of meals requested.
7. PCS will be responsible for care and cleaning of said equipment to ensure environmental health and safety standards are met. This includes thermometers and transportation and service containers.
8. PCS shall have available for return all meal transportation and service containers on the following day.
9. Once delivered PCS will be responsible for maintaining the proper temperature of all meal components until and through the time of service and meal counting.
10. SCCS will provide PCS with brown sack lunches, which meet the National School Lunch Program meal requirements for field trips when requested by PCS at least five (5) working days in advance. The cost of these 'sack lunches' will be the same as for the regular lunches.

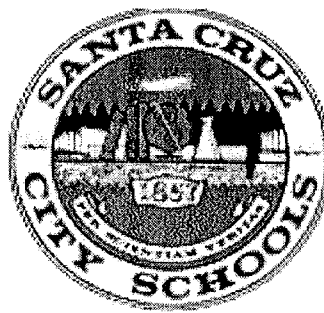

11. PCS shall provide the necessary personnel to serve and supervise the consumption of the meals according to USDA/CDE rules.
12. SCCS shall provide the PCS with a monthly menu covering both breakfast and lunch to be served for the following month. SCCS reserves the right to change the menu when necessary due to seasonal availability, unanticipated cost fluctuations, or otherwise.
13. SCCS shall make application for those commodity foods (served under this agreement) which may be available for use in the preparation of PCS meals.
14. Gifts or exchanges of USDA foods are not permitted. Until it is consumed by the student, the food prepared remains the property of the CDE, USDA and SCCS. It cannot be sold, given away or exchanged for other goods
15. PCS will provide SCCS with a Board approved school year calendar at least 30(thirty) days prior to the beginning of the school year. PCS will inform SCCS at least 2 (two) weeks in advance of any changes to this calendar.
16. SCCS shall maintain all necessary records on the nutritional components of meals; the number of meals made available to the PCS; and make said records available for inspection by PCS, CDE and USDA authorities when requested.
17. SCCS will make available for review by PCS all documents generated in maintaining the preparation site; including, but not limited to: SC County Health Inspections, H.A.C.C.P. inspections, and the CDE Coordinated Review Effort.
18. PCS agrees to pay SCCS a monthly administrative fee for the preparation of menus, nutritional compliance, special dietary needs, procurement practices and required record preparation in accordance with attached Exhibit A
19. PCS agrees to pay SCCS for each student meal ordered in accordance with attached Exhibit A. PCS will submit payment to SCCS Food Service Department 310 La Fonda Ave. Santa Cruz 95062 within 30 days of receipt of billing.
20. PCS agrees to pay SCCS for each adult meal ordered in accordance with the attached Exhibit A.
21. COE shall indemnify and hold SCCS and its officers, employees and agents harmless for any/all liability arising out of PCS's performance in the service of all meals.
22. PCS may contract additional required USDA professional standards training and/or training for program setup at the rate of \$100.00 dollar per hour.

SANTA CRUZ CITY SCHOOLS
133 Mission Street Ste. 100
Santa Cruz Ca. 95062
831-429-3410

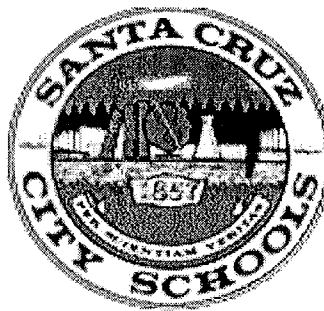

FOOD SERVICES DEPARTMENT
310 LA FONDA AVE
SANTA CRUZ CA 95062
831-429-3850
fax: 831-429-3849

23. Once approved, this agreement is permanent. Either party may terminate this agreement for cause upon a thirty day written notice. Notice of termination will be provided in writing to the CDE, Nutrition Division.

24. All business and information relating to the execution of this agreement and the services thereof, including kitchen visitations, must be directed to the Director of Food Services.

SANTA CRUZ CITY SCHOOLS

BY: _____
Jim Monreal, Asst. Superintendent

BY: _____
Amy Hedrick-Farr, FS Director

DATE: _____

DATE: _____

PACIFIC COLLEGIATE SCHOOL

SIGNATURE: MC Reitano

SIGNATURE: _____

WRITTEN NAME: Maia C. Reitano

WRITTEN NAME: _____

DATE: June 29, 2022

DATE: _____

SANTA CRUZ CITY SCHOOLS
 133 Mission Street Ste. 100
 Santa Cruz Ca. 95062
 831-429-3410

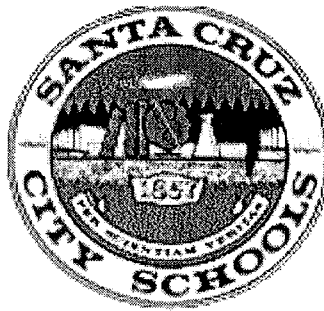

FOOD SERVICES DEPARTMENT
 310 LA FONDA AVE
 SANTA CRUZ CA 95062
 831-429-3850
 fax: 831-429-3849

Exhibit A

School Year	Administrative Fee
2022-2023	\$2500.00 monthly

School Year	Student Breakfast Price	Adult Breakfast Price
2022-2023	\$2.75	\$3.75
	Student Lunch Price	Adult Lunch Price
	\$5.00 with USDA foods	\$6.00
	\$5.50 without USDA foods	

SANTA CRUZ CITY SCHOOL DISTRICT

AGENDA ITEM: Food Service Agreement with Santa Cruz County Office of Education

MEETING DATE: August 17, 2022

FROM: Jim Monreal, Assistant Superintendent of Business Services

THROUGH: Kris Munro, Superintendent

RECOMMENDATION:

Approve the interagency agreement between Santa Cruz City Schools Food Services Department and the Santa Cruz County Office of Education.

BACKGROUND:

The Santa Cruz City Schools Food Service Department will prepare meals for Santa Cruz County Office of Education's Alternative Education Programs. These meals will meet or exceed the National School Lunch Program requirements. This agreement will provide revenue for the food services department.

FISCAL IMPACT:

\$105,000 yearly revenue

This work is in direct support of the following District goals and their corresponding metrics:

Goal #2: SCCS will create positive, engaging school environments that promote the development of cognitive skills and the social emotional well-being of all students.

Goal #5: SCCS will maintain a balanced budget and efficient and effective management.

Goal #6: SCCS will maintain strong communication and partnership with its diverse community.

SANTA CRUZ CITY SCHOOLS
133 Mission Street Ste. 100
Santa Cruz Ca. 95062
831-429-3410



FOOD SERVICES DEPARTMENT
310 LA FONDA AVE
SANTA CRUZ CA 95062
831-429-3850
fax: 831-429-3849

This interagency agreement entered into July 1, 2022, by and between Santa Cruz City Schools Food Services Department, hereafter referred to as “SCCS” and Santa Cruz County Office of Education, hereafter referred to as “COE” is made for the purpose to vend meals which meet or exceed the National School Lunch Program meal requirements for the COE’s Alternative Education Programs.

It is hereby agreed that:

1. SCCS shall prepare meals that meet or exceed the National School Lunch Program meal requirements, maintaining temperature and quality of meals for and until receipt by COE staff for delivery to COE school sites. Breakfast & lunch must comply with the nutritional standards for meals as established by the USDA and CDE.
2. SCCS shall and will provide the necessary utensils, serving materials, trays and napkins for each COE site. SCCS will provide transportation and time / temperature logs and training on their use to COE personnel.
3. SCCS shall provide the number of lunches requested each school day that COE is in session. If scheduling conflicts based on differing school calendars shall occur, SCCS will make arrangements to ensure qualified reimbursable meals are provided.
4. The number of breakfast & lunches prepared by SCCS shall be equal to the number of meals requested by COE.
5. COE shall notify SCCS no later than 2pm two day’s prior of the number of meals required for service. Change notifications must be communicated to the Central Kitchen at (831)429-3810 or by email to the Food Service Director.
6. COE will be obligated to accept and pay for the number of meals requested.
7. COE shall provide all equipment necessary to transport the meals to the specific COE contracted sites. COE will be responsible for care, cleaning and maintenance of said equipment to ensure environmental health and safety standards for Food Safety and Handling are met. This includes thermometers and transportation and service containers.
8. COE shall return all meal transportation and service containers on the following day.
9. COE will be responsible for maintaining the proper temperature of all meal components until and through the time of service and meal counting.



10. SCCS will provide COE with brown sack lunches, which meet the National School Lunch Program meal requirements for field trips when requested by COE at least five (5) working days in advance. The cost of these 'sack lunches' will be the same as for the regular lunches.
11. COE shall provide the necessary personnel to transport, serve and supervise the consumption of the meals according to USDA/CDE rules.
12. SCCS shall provide the COE with a monthly menu covering both breakfast and lunch to be served for the following month. SCCS reserves the right to change the menu when necessary due to seasonal availability, unanticipated cost fluctuations, or otherwise.
13. SCCS shall make application for those commodity foods (served under this agreement) which may be available for use in the preparation of COE meals.
14. Gifts or exchanges of commodities are not permitted. Until it is consumed by the student, the food prepared remains the property of the CDE, USDA and SCCS. It cannot be sold, given away or exchanged for other goods
15. COE will provide SCCS with a Board approved school year calendar at least 30(thirty) days prior to the beginning of the school year. COE will inform SCCS at least 2 (two) weeks in advance of any changes to this calendar.
16. SCCS shall maintain all necessary records on the nutritional components of meals; the number of meals made available to the COE; and make said records available for inspection by COE, CDE and USDA authorities when requested.
17. SCCS will make available for review by COE all documents generated in maintaining the preparation site; including, but not limited to: SC County Health Inspections, H.A.C.C.P. inspections, and the CDE Coordinated Review Effort.
18. COE agrees to pay SCCS for each student meal ordered in accordance with attached Exhibit A. The COE will submit payment to SCCS Food Service Department 310 La Fonda Ave. Santa Cruz 95062 within 30 days of receipt of billing.
19. COE agrees to pay SCCS for each adult meal ordered in accordance with the attached Exhibit A.
20. COE shall indemnify and hold SCCS and its officers, employees and agents harmless for any/all liability arising out of COE's performance in the delivery of all meals.
21. This agreement includes all COE participating school sites in its application/agreement with the CDE.

SANTA CRUZ CITY SCHOOLS
133 Mission Street Ste. 100
Santa Cruz Ca. 95062
831-429-3410



FOOD SERVICES DEPARTMENT
310 LA FONDA AVE
SANTA CRUZ CA 95062
831-429-3850
fax: 831-429-3849

- 22. Once approved, this agreement is permanent. Either party may terminate this agreement for cause upon a thirty day written notice. Notice of termination will be provided in writing to the CDE, Nutrition Division.
- 23. All business and information relating to the execution of this agreement and the services thereof, including kitchen visitations, must be directed to the Director of Food Services.

SANTA CRUZ CITY SCHOOLS

BY: _____
Jim Monreal, Asst. Superintendent

BY: _____
Amy Hedrick-Farr, FS Director

DATE: _____

DATE: _____

SANTA CRUZ COUNTY OFFICE OF EDUCATION

SIGNATURE: Johnny Rice

SIGNATURE: [Signature]

WRITTEN NAME: John K Rice

WRITTEN NAME: Liann Reyes, Depty Supt-Bus Svcs

DATE: 06-13-2022

DATE: June 13, 2022

SANTA CRUZ CITY SCHOOLS
 133 Mission Street Ste. 100
 Santa Cruz Ca. 95062
 831-429-3410



FOOD SERVICES DEPARTMENT
 310 LA FONDA AVE
 SANTA CRUZ CA 95062
 831-429-3850
 fax: 831-429-3849

Exhibit A

School Year	Student Breakfast Price	Adult Breakfast Price
2022-2023	\$2.75	\$3.75

School Year	Student Lunch Price	Adult Lunch Price
2016-2017	\$3.00	\$4.00
2017-2018	\$3.00	\$4.00
2018-2019	\$3.00	\$4.00
2019-2020	\$3.25	\$4.25
2020-2021	\$3.25	\$4.25
2021-2022	\$3.50	\$4.50
2022-2023	\$3.75	\$4.75

SANTA CRUZ CITY SCHOOL DISTRICT

AGENDA ITEM: Memorandum of Understanding: Transportation Services: SCCS & COE

MEETING DATE: August 17, 2022

FROM: Jim Monreal, Assistant Superintendent of Business Services

THROUGH: Kris Munro, Superintendent

RECOMMENDATION:

Approve the Agreement between Santa Cruz City Schools and the County Office of Education to provide transportation for a student.

BACKGROUND:

Santa Cruz City Schools is the largest district in the Special Education Local Planning Area (SELPA) and provides the largest continuum of services for special education students in the Special Education Local Planning Area. On occasion, neighboring districts or the Santa Cruz County Office of Education may seek to have students transported by SCCS because routing is more efficient or cost effective than for the educational agency to provide it on their own. In these instances, SCCS may enter into an agreement whereby SCCS provides transportation for an out of district student and then charges the education agency for such services. Similarly, a neighboring district may transport SCCS student(s) for reasons of efficiency.

The following MOU is proposed for the 2022-23 school year:

- SCCS will provide transportation to one secondary Santa Cruz County Office of Education student.

FISCAL IMPACT:

Where Transportation provision is not an exchange, this work will generate revenue to SCCS at a rate of \$50 per day. Final amount received will be dependent upon student attendance.

This work is in direct support of the following District goals and their corresponding metrics:

Goal #1: All Santa Cruz City Schools students will be prepared to successfully access post-secondary college and career opportunities.

Goal #3: We will eliminate the achievement gaps that currently exist between demographic groups within the SCCS student community.

SANTA CRUZ CITY SCHOOLS TRANSPORTATION SERVICES AGREEMENT for [REDACTED]

THIS AGREEMENT is entered into this day July 25, 2022, between

Santa Cruz County Office of Education
400 Encinal Street
Santa Cruz, CA 95060
Hereinafter referred to as COE, and

Santa Cruz City Schools
133 Mission Street, Suite 100
Santa Cruz, CA 95060
Hereinafter referred to as SCCS

THE PARTIES MUTUALLY AGREE AS FOLLOWS:

1. SCCS shall transport student [REDACTED] to and from Cabrillo College COE program on Lower Perimeter Road, Aptos, and LCI Mosaic Manor, 144 South Park Way, Santa Cruz.
2. COE shall provide student contact information and access to student through SEIS.
3. The SCCS vehicle used in this transportation may be a SCCS white van or SCCS school bus, driven and controlled by a SCCS School Bus Driver.
4. This agreement shall be effective Tuesday 08/10/2022, and continue through Thursday 05/25/2023, unless terminated earlier by either party.
5. This agreement may be terminated by either party at any time during this agreement, by notifying the other party by e-mail and indicating COE is resuming transportation.
6. SCCS shall be compensated by COE at the rate of \$50.00 per day, derived by \$25 each direction, \$25 to Cabrillo, \$25 returning from Cabrillo for a total of \$50 per day.
7. SCCS shall invoice COE for services promptly after concluding the service, and shall be compensated within a reasonable time thereafter.
8. SCCS shall be excused from performance, without penalty, during such time and to the extent prevented from performing by Acts of God, fire, earthquake, strike, lockout, civil disorder, war, or other unforeseeable events.
9. During the term of this agreement, SCCS shall maintain the following types of Insurance:
 - a. Comprehensive general liability insurance, including owned – motor vehicle liability insurance with respect to the services provided by, or on behalf of SCCS

under this Agreement. Liability insurance for death, bodily injury and property damage shall be for no less than \$5,000,000 per occurrence for general liability and automobile liability.

- b. Worker's compensation insurance as required by law to protect SCCS from claims which may arise from its operations under this Agreement. Employer's Liability Insurance with limits of not less than \$1,000,000.
 - c. SCCS agrees that prior to performing any serviced required by this Agreement, true and correct copies of all certificates of insurance reflecting the coverage required by this paragraph shall be provide to COE.
10. SCCS shall hold harmless and indemnify COE, its governing board of officers, agents and employees, from and against any and all demands, losses, claims, legal and investigative expenses or liabilities of any kind which said governing board officers, agents or employees may sustain or incur, or which may be imposed upon them for injury or death of persons as a direct result of, or out of negligence or willful misconduct on the part of SCCS, its officers, agents or employees, while carrying out the terms of this agreement.
 11. COE shall hold harmless and indemnify SCCS, its officers, agents, and employees, from and against any and all demands, losses, claims, legal and investigative expenses or liabilities of any kind which said officers, agents or employees may sustain or incur, or which may be imposed upon them for injury or death of persons as a direct result of, or arising out of negligence or willful misconduct on the part of COE, its officers, agents or employees, while carrying out the terms of this agreement.
 12. While engaged in and carrying out its obligations under the terms of this Agreement, SCCS is an independent contractor, and not an officer, agent or employee of COE.
 13. COE shall be held responsible for any defacement of or damage to equipment owned by SCCS which is caused by COE.
 14. SCCS is not responsible and creates no bailment for personal items carried aboard or placed in luggage compartments of its vehicles.
 15. SCCS drivers shall be responsible for following and enforcing the rules and policies relating to school bus operating, as well as complying with all the laws and regulations relating to school bus transportation as specified in – California – Codes.
 16. This Agreement contains the entire understanding between SCCS and COE. All prior oral agreements, understandings, representations or statements are here by merged into this Agreement, and shall have no further force or effect.

TRANSPORTATION SERVICES AGREEMENT BETWEEN SANTA CRUZ CITY SCHOOLS AND SANTA CRUZ COUNTY OFFICE OF EDUCATION for [REDACTED]

BY SIGNATURE BELOW, THE PARTIES MUTUALLY AGREE TO THE TERMS AND CONDITIONS CONTAINED HEREIN.

SANTA CRUZ COUNTY OFFICE OF EDUCATION

SANTA CRUZ CITY SCHOOLS

By:  _____
Signature

By: _____
Signature

Liann Reyes
Name: _____
Print

Name: _____
Print

Deputy Supt-Bus Services
Title: _____

Title: _____

Date: 07 / 25 / 2022 _____

Date: _____

UnSANTA CRUZ CITY SCHOOL DISTRICT

AGENDA ITEM: Bay View Elementary Portable Classroom Purchase

MEETING DATE: August 17, 2022

FROM: Jim Monreal, Assistant Superintendent, Business Services

THROUGH: Kris Munro, Superintendent

RECOMMENDATION:

Approve Purchase and Sale Agreement Between Santa Cruz City Schools (SCCS) and Campus Kids Connection, Inc. for SCCS to purchase a Campus Kids Connection-owned portable classroom building located at Bay View Elementary School.

BACKGROUND:

In 2008, Campus Kids Connection purchased a used portable classroom building (Portable) from SCCS for operation of its after-school program at Bay View Elementary. Campus Kids Connection no longer operates a program at Bay View and is willing to sell the Portable to SCCS for One Dollar (\$1.00). SCCS wishes to purchase the Portable from Campus Kids Connection to provide needed additional program space at the Bay View campus.

FISCAL IMPACT:

One Dollar (\$1.00) Funding Source – Lease revenue (Unrestricted)

Approval of the Purchase and Sale Agreement directly supports the following District goal and corresponding metrics:

Goal #5: SCCS will maintain a balanced budget and efficient and effective management.

**PURCHASE AND SALE AGREEMENT
FOR PORTABLE CLASSROOM BUILDING**

This Purchase and Sale Agreement for Portable Classroom Building (“Agreement”) is entered into as of _____, 2022 (“Effective Date”) by and between Santa Cruz City Schools (“District”), a California public school district with its principal offices located at 133 Mission Street, Suite 100, Santa Cruz, California 95060, and Campus Kids Connection, Inc. (“CKC”), a California non-profit public benefit corporation, with its principal offices located at 2425 Porter Street, Suite 18, Soquel, California 95073. The District and CKC may each be referred to individually as “Party” or together as the “Parties” in this Agreement.

RECITALS

- A. WHEREAS, CKC owns a 1997 portable classroom building (“Portable”), 20 x 40 feet in size, manufactured by Gary Doupnik Manufacturing, Inc., bearing Mfg. No. 4746 and VIN No. 10-97-DH-8202, and as more particularly identified by the metal tag and other identifying information affixed to the exterior of the Portable, photos of which are attached hereto as Exhibit A and incorporated herein by reference; and
- B. WHEREAS, the Portable is presently located on the District’s Bay View Elementary School campus located at 1231 Bay Street in Santa Cruz, California 95060; and
- C. WHEREAS, the District desires to purchase the Portable from CKC and CKC desires to sell the Portable to District subject to the terms and conditions of this Agreement.

NOW THEREFORE the Parties agree as follows.

AGREEMENT

- 1. Purchase and Sale. CKC hereby sells to the District and the District hereby purchases from CKC, the Portable for the total purchase price of One Dollar (\$1.00) (“Purchase Price”) on the terms and conditions set forth herein. The District shall deliver the Purchase Price to CKC within ten (10) business days of the Effective Date. The District shall assume sole responsibility for the Portable and risk of loss and ownership once title to the Portable has transferred to the District as set forth in Section 2 below.
- 2. Transfer of Title. Title to the Portable shall be deemed to have been transferred to the District upon completion of all of the following: execution of this Agreement by both Parties; ratification of the Agreement by the District’s Governing Board; the District’s delivery of the Purchase Price to CKC; and the Parties’ execution of the Bill of Sale in the form attached hereto as Exhibit B and incorporated herein by reference.
- 3. Warrant of Ownership. CKC represents and warrants that it is the lawful owner of the Portable with the full right and authority to transfer title to the Portable to the District and that title to the Portable shall be transferred to the District free and clear of all liens and encumbrances.

4. Condition; Furniture and Equipment.

- a. The Parties agree that the Portable is sold in its "AS IS" "WHERE IS" condition as of the Effective Date of this Agreement and the District accepts the Portable in that condition. CKC makes no warranties whatsoever, express, implied, statutory or otherwise, including without limitation, any warranties of merchantability or fitness for a particular purpose, regarding the Portable or its continued use by District.
- b. The Parties further agree that the Portable is being sold to the District inclusive of all furniture, fixtures, and equipment presently contained within or affixed to the Portable.

5. Notices. All notices required to be given between the Parties shall be in writing and transmitted by any of the following methods: (1) facsimile (fax) with proof of transmission; (2) overnight mail with proof of delivery; (3) email provided receipt is acknowledged; (4) personal delivery; (5) certified mail, return receipt requested; or (6) by regular mail placed in the United States Mail, postage prepaid, as follows:

To Santa Cruz City Schools:

Attn: Assistant Superintendent, Business Services
Santa Cruz City Schools
133 Mission Street, Suite 100
Santa Cruz, CA 95060
Email: jmonreal@sccs.net
Fax: 831-429-3439

To CKC

Attn: Executive Director
Campus Kids Connection, Inc.
2425 Porter Street, Suite 18
Soquel, CA 95073
Email: noel@campuskidsconnection.com

6. Miscellaneous Provisions.

- a. Entire Agreement. This Agreement is intended by the Parties as the final expression of their agreement with respect to such terms as are included herein and as the complete and exclusive statement of its terms and may not be contradicted by evidence of any prior agreement or of a contemporaneous oral agreement, nor explained or supplemented by evidence of consistent additional terms.
- b. Binding Effect. This Agreement is binding upon the successors and assigns of both Parties.
- c. Assignment. No Party to this Agreement shall assign or transfer any of its obligations, rights, or duties under this Agreement.
- d. Governing Law/Venue. This Agreement shall be governed by and interpreted under the laws of the State of California. Any action or proceeding seeking any relief under or with respect to this Agreement shall be brought solely in the Superior Court of the State of

California for Santa Cruz County, subject to any transfer of venue as required by law.

- e. Amendment. This Agreement may be modified or superseded only by written instrument executed by duly authorized representatives of each of the Parties.
- f. Execution in Counterparts. This Agreement may be executed in counterparts such that the signatures may appear on separate signature pages. A copy, or an original, with all signatures appended together shall be deemed a fully executed Agreement. Signatures transmitted by facsimile shall be deemed original signatures.
- g. Signature Authority. Each Party warrants and represents that it has full power and authority to enter into and perform this Agreement, and that the person signing this Agreement on behalf of each Party has been properly authorized and empowered to enter into this Agreement.

IN WITNESS WHEREOF, the Parties hereto have executed this Agreement on the last date indicated below.

CAMPUS KIDS CONNECTION

SANTA CRUZ CITY SCHOOLS

Noel Schermann, Executive Director

Kris Munro, Superintendent

Date: _____

Date: _____

EXHIBIT A

PHOTOS OF IDENTIFYING INFORMATION AFFIXED TO PORTABLE

EXHIBIT A1



EXHIBIT A2



EXHIBIT B

BILL OF SALE

BE IT KNOWN, that for good consideration, and in payment of the sum of One Dollar (\$1.00), the receipt and sufficiency of which is acknowledged, the undersigned Noel Schermann, Executive Director, Campus Kids Connection, Inc. 2425 Porter Street, Suite 18, Soquel, CA 95073 (Seller) hereby sells and transfers to Santa Cruz City Schools, 133 Mission Street, Santa Cruz, CA 95060 (Buyer) the following:

One (1) 24 x 40' Portable Classroom, manufactured in 1997 by Gary Doupnik, Manufacturing, Inc., bearing Mfg. No. 4746 and VIN No. 10-97-DH-8202, and presently located on Buyer's Bay View Elementary School campus at 1231 Bay Street in Santa Cruz, California 95060 (Portable).

Such transfer and sale is made, and Buyer hereby accepts title to and possession of the Portable, in its current "AS-IS, WHERE-IS" condition, subject to the terms of that certain *Purchase and Sale Agreement for Portable Classroom Building* made and executed by Buyer and Seller and dated _____, 2022, and without any representations or warranties from Seller whatsoever, express, implied, statutory or otherwise, including without limitation, any warranties of merchantability or fitness for a particular purpose.

Executed by Buyer and Seller this _____ day of _____, 2022.

BUYER:

By: _____

Kris Munro
Superintendent
Santa Cruz City Schools

SELLER:

By: _____

Noel Schermann
Executive Director
Campus Kids Connection, Inc.

SANTA CRUZ CITY SCHOOL DISTRICT

AGENDA ITEM: Consultant Services Agreement: Lisa Fraser

MEETING DATE: August 17, 2022

FROM: Molly Parks, Assistant Superintendent of Human Resources

THROUGH: Kris Munro, Superintendent

RECOMMENDATION:

Approve Consultant Service Agreement for Principal coaching in the 2022-23 school year.

BACKGROUND:

As a support given to all new Principals in SCCS, Lisa Fraser will provide coaching support for a new principal in the district this year. Lisa Fraser is a retired administrator who brings significant experience to this coaching position. Ms. Fraser has held several leadership positions in both Santa Cruz and Santa Clara County.

FISCAL IMPACT:

Not to exceed \$3,000 Title II (Restricted)

This work is in direct support of the following District goal and its corresponding metrics:

Goal #4: We will develop a highly collaborative, professional culture focused on supporting effective teaching.

Goal #5: SCCS will maintain a balanced budget and efficient and effective management.

Goal #6: SCCS will maintain strong communication and partnerships with its diverse community.

REQUEST FOR CONSULTANT SERVICES AGREEMENT

Submit to the responsible Assistant Superintendent at least two weeks before the Board meeting and prior to the Consultant beginning work.

Site: Human Resources Principal/Director: Desiree Dominguez

Describe Work to be Performed and District and Site Goals Supported:
Administrative Coaching for _____ . In support of District Goals #3 and #4

Qualifications of Consultant: Educational Leadership Coach

Name of Consultant: Lisa Fraser Tax I.D.# or SSN: _____
(Vendor Data form to Purchasing)

Address: _____ Telephone #: _____

City/State/Zip: _____ Email: fraserlisa13@gmail.com

Date(s) of Service: _____ Time: Various

Number of Hours: NA hours per day X NA days = NA total hours.

Hourly/Daily Rate (specify): NA Meals: NA

Lodging: NA Transportation: NA

TOTAL FEE TO BE PAID: \$3000 (2 days per month) Account #: 01-4035-0-0000-2700-5800-920-0000

Write out meaning of account number: Title II Professional Development Elementary

Approval of Business Services verifying account: [Signature] Date: 6/22/22

Authorized Signature of Consultant: [Signature] Date: 6/19/2022
(NOTE: Consultant must submit invoice for payment upon completion of work)

Signature of Administrator Requesting Service: [Signature] Approval of Assistant Superintendent: _____

Date: _____ Date: _____

AB 1610, 1612, and 2102 COMPLIANCE (consultants having more than limited contact with students require fingerprinting)

- Consultants **will be** on campus on a regular basis (more than once) while students are present
- Consultant **will not** be on campus on a regular basis while students are present (fingerprints not required).

Fingerprint Clearance date: N/A Approval of Human Resources: Jory Berdan

PAYMENT AUTHORIZATION
(Submit for payment after Consultant completes work)

I hereby certify that the consultant has satisfactorily completed the services in accordance with the above Agreement and that payment is in order.

Signature of Administrator Requesting Payment _____ Date _____

Approval of Assistant Superintendent _____ Date _____

Board of Education Approval: _____
(Required if over \$2500)

7/14/2016

REQUEST FOR CONSULTANT SERVICES AGREEMENT

Review guidelines of Board Policy - Consultant Services Agreements.

1. Statement of specific need and the goal of the Consultant's work (Refer to district/site goals and plans, unique needs of school, program or office which necessitates the services of a consultant).

Ms. Fraser will support our administrative team with educational leadership coaching.

2. State efforts made to identify qualified staff available within the district to carry out the requested services.

Staff have identified Ms. Fraser as having the knowledge and expertise to support our new administrators; including educational leadership coaching with the New Teacher Center, Co-Director of the former California Center for Baldrige in Education - SCCOE, Superintendent Mentorship, and 30-plus years of experience as an educational leader.

3. If this agreement is for staff development or for one-time services, state the site's plan to reduce or eliminate the need for this consultant's services in the future.

The District previously contracted with the New Teacher Center for principal inductions at a much greater cost. Contracting with Ms. Fraser directly is a savings to the district.

4. Statement of expected outcomes (Include specific student outcomes desired, benefits to district students and/or staff).

Supporting new administrators in order to improve instructional leadership, providing meaningful development feedback to teachers, promoting a culture that serves the needs of all students and district participants alike to improve student achievement.

5. Evaluation Process - How will you know the goal/outcomes have been met?

At the beginning of the school year, administrators identify goals and metrics for the year relative to the California Professional Standards for the Educational Leader. We expect significant growth towards these goals to be reported on their end of year summative evaluation.

SANTA CRUZ CITY SCHOOLS DISTRICT

AGENDA ITEM: Memorandum of Understanding: University Placement Agreements with Santa Cruz City Schools 2022-23

DATE: August 17, 2022

FROM: Molly Parks, Assistant Superintendent, Human Resources

THROUGH: Kris Munro, Superintendent

RECOMMENDATION:

Approve the Memorandums of Understanding with University Placements and Santa Cruz City Schools for the 2022-23 school year.

BACKGROUND:

The Memorandums of Understanding between various colleges and Santa Cruz City Schools allows students from those colleges to work with Santa Cruz City Schools for student teaching, internships and other experiences needed for their program. The Memorandum of Understanding agreements occur throughout the school year. The attached Memorandums of Understanding agreements are for the 2022-23 school year through the 2024-25 school year.

FISCAL IMPACT:

None

This work is in support of the following District Goals and their corresponding metrics:

Goal #4: We will develop a highly collaborative, professional culture focused on supporting effective teaching.

Goal #6: SCCS will maintain strong communication and partnerships with its diverse community.



California State University, Monterey Bay

The Department of Education and Leadership - CSUMB Internship Programs
Building 3 • 100 Campus Center • Seaside, CA 93955-8001 (831) 582-3639

INTERN Memorandum of Understanding between CSU Monterey Bay Internship Programs and

SANTA CRUZ CITY SCHOOLS

Name of School/District

University intern programs are a partnership between the Commission on Teacher Credentialing approved program sponsor (CSU Monterey Bay) and the California employing agency (School District/County Office of Education/Charter School) that elects to employ an individual on the basis of an intern credential. Prior to an intern teacher assuming daily teaching responsibilities, a signed Memorandum of Understanding must be in place between the Commission approved program sponsor and the California employing agency detailing the support and supervision that will be provided. (California Code of Regulations 80033)

By signing this agreement, the School agrees to:

- Assign the intern an appropriate placement authorized by their intern credential
- Offer the intern a contract that qualifies for the intern credential and meets the requirements of ED Code 44462 which states, "In no event may an intern be paid less than a minimum salary required to be paid by the state to a regularly certified teacher."
- Assign the intern a class that includes the presence of students with exceptionalities and English Language Learners, at a site with a fully qualified site administrator
- Assign the intern a classroom with technology that can be used for educational purposes
- Agree not to assign the intern adjunct duties or professional development/training obligations that interfere with his/her university class schedule or are inappropriate for a beginning teacher. Interns must be on campus by 4:15pm on class meeting days.
- Provide release time for both the intern (minimum of 1 day per semester) and the intern Support Provider to do observations (minimum of 2 days per semester)
- To terminate the training at any time, if it is found that continuation would be detrimental to the children involved; consider terminating it at the end of the semester if the intern support provider assigned by the district and/or the university supervisor report that based on performance to date, the intern would not be recommended for a credential.
- Assign a teacher within the school setting and with equivalent instructional assignment as a Support Provider to the intern, prior to the intern assuming daily teaching responsibilities (CTC Coded Correspondence 14-04). The assigned teacher will hold a Clear credential with an English Learner Authorization, in the same subject area, and have a minimum of three years of successful experience

- Understand that the CSUMB intern program is now a two year program, and the intern must maintain a Support Provider for the duration of time while serving on an intern credential.
- CSUMB will not be responsible for any payment to Support Providers.
- The employer and intern will collaborate to track the hours of support, mentoring and supervision to ensure that all required hours are met
- An intern teacher who is employed after the beginning of a school year shall be provided support, mentoring and supervision in the amount of 4 hours times the number of instructional weeks remaining in the school year
- Provide staff development activities and other resources (site and district support) that enhance the intern's teaching skills
- Hire as interns only those teacher candidates who are properly credentialed and who have met pre-service professional preparation required by the Commission on Teacher Credentialing
- Require attendance at a Support Provider training, if offered by CSUMB
- Return the signed copy of the Intern MOU to CSU Monterey Bay
- In collaboration with CSUMB, ensure that the intern receives a minimum of 2 to 4 hours of support, mentoring and supervision per week as required by the California Code of Regulations 80033. The School will be responsible for providing 169 hours of support, mentoring and supervision to each CSUMB intern per year, which will include 45 hours of support and mentoring for those who do not hold an English Learner Authorization. CSUMB will ensure that the intern has completed 45 hours of early field experience, 120 hours of pre-service coursework, plus CBEST, CSET or Subject Matter Waiver program, B.A, US Constitution, and fingerprint clearance prior to receiving the intern credential. Support, mentoring and supervision by a Clinical Coach will be provided by CSUMB in the amount of 20 hours each year. Please see the chart below outlining the collaborative effort to support, mentor and supervise interns:

Support, Mentoring and Supervision Hours Required by the State for Interns

45 hours Early Field Experience (Verified by CSUMB prior to receiving an intern credential.)
120 hours Preservice (Verified by CSUMB prior to receiving an intern credential.)
189 hours Support, Mentoring and Supervision PER YEAR

School

Support, Mentoring, and Supervision provided per year:

169 hours (Forty-five of these hours must be focused on the teaching of English Learners.)

What hours can count as Support/Mentoring?

- All communication provided by the school site that provides support and mentoring to the intern
- Support Provider mentoring
- Professional Development provided by the school
- Department level meetings
- Observation and feedback by other teacher staff
- Collaboration time
- Evaluations and observations by the Principal
- Observation time in other classrooms

CSUMB

45 hours Early Field Experience – Verified prior to the intern credential
120 hours Preservice coursework (3 summer courses) – Verified prior to the intern credential.

Support, Mentoring and Supervision provided per year:

20 hours (10 Class visits during one practicum per year, plus feedback, one class visit per ED 600 Intern Seminar per year)

CSUMB ensures that intern applicants have completed 45 hours of Early Field Experience, and 120 hours of pre-service through completion of summer pre-service coursework, prior to the issuance of the intern credential. CSUMB sends a Clinical Coach to visit interns during the semesters they are taking a practicum course. Interns must enroll in ED 600, Intern Seminar, to provide ongoing support in semesters they do not take practicum. During Intern Seminar, the Clinical instructor visits the classroom of the intern a minimum of one time during the semester and provides additional support through class meetings.



California State University, Monterey Bay

The Department of Education and Leadership - CSUMB Internship Programs
Building 3 • 100 Campus Center • Seaside, CA 93955-8001 (831) 582-3639

The CSU Monterey Bay Department of Education and Leadership agrees to:

- Ensure that the intern candidate is in good standing in the program, has completed 45 hours early field experience, 120 hours of pre-service coursework, CBEST, CSET or Subject Matter Waiver program, acceptable bachelor's degree, US Constitution, and fingerprint clearance, prior to receiving the intern credential.
- Seek available grant funding, if possible.
- Ensure that the employed intern is continuously enrolled in CSUMB intern program coursework while serving on the intern credential, and withdraw the intern credential if enrollment ceases.
- Issue an intern credential to eligible candidates which will include the English Learner Authorization and remain valid for two years in the district specified at time of application, as long as enrollment continues and the intern remains eligible.
- Provide advisement to the intern regarding the best sequence of courses to complete the program in a timely manner (See program plans here: www.csumb.edu/teach)
- Provide 20 hours of support, mentoring and supervision per year to the intern through classroom visits and feedback by a Clinical Coach and Seminar instructor
- Schedule courses to provide flexible offerings for students in intern placements
- Involve the Districts, County Offices of Education, and University, to foster collaborative teacher preparation practices to enrich the Internship Program.

Please sign, keep a copy for your records, and return the original to:

*CSUMB Department of Education and Leadership
Credential Analyst
100 Campus Center
Seaside, CA 93955*

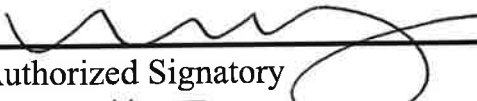
	<i>5/5/2022</i>
Authorized Signatory	Date
<i>Molly Parks</i>	<i>ASST SUP HR</i>
Name and Title	
<i>Cathi Draper Rodriguez</i>	<i>03/28/2022</i>
Dr. Cathi Draper Rodriguez, Chair, Department of Education & Leadership	Date

The term of this Memorandum of Understanding is from July 1, 2022 to June 30, 2027. Provisions of this agreement may be updated during the term in the event of mandatory changes to curriculum or practices required by the Commission on Teacher Credentialing. Should an update be required, it will be the responsibility of CSUMB to issue an updated MOU to the

The guidelines set forth in this MOU are directed by the following state documents:

California Code of Regulations 80033:

[https://govt.westlaw.com/calregs/Document/IB2CCAF809BED11E3AC56D7E7B5173B3B?viewType=FullText&originationContext=documenttoc&transitionType=CategoryPageItem&contextData=\(sc.Default\)](https://govt.westlaw.com/calregs/Document/IB2CCAF809BED11E3AC56D7E7B5173B3B?viewType=FullText&originationContext=documenttoc&transitionType=CategoryPageItem&contextData=(sc.Default))

CTC Educator Preparation Program Standards:

<http://www.ctc.ca.gov/educator-prep/STDS-prep-program.html>

California Education Code 44462 States – “In no event may an intern be paid less than a minimum salary required to be paid by the state to a regularly certified teacher.”

<http://www.leginfo.ca.gov/cgi-bin/displaycode?section=edc&group=44001-45000&file=44450-44468>

California Teaching Performance Expectations:

<http://www.ctc.ca.gov/educator-prep/TPA-files/TPEs-adopted-2016.pdf>

Education Code:

44462: <http://law.onecle.com/california/education/44462.html>

CTC Program Sponsor Alert 13-06: <http://www.ctc.ca.gov/educator-prep/PS-alerts/2013/PSA-13-06.pdf>

CTC Coded Correspondence 14-04: <http://www.ctc.ca.gov/notices/coded/2014/1404.pdf>

CSU Monterey Bay Program Information

Intern Forms Page

<https://csumb.edu/teach/introduction-internship-step-step-guide-0/intern-forms/>

Program Plans:

Multiple Subject Program:

[https://csumb.edu/teach/elementary-education/](https://csumb.edu/teach/elementary-education-/)

Single Subject Program:

<https://csumb.edu/teach/secondary-education/>

Special Education Program:

<https://csumb.edu/teach/special-education/>



Addendum to the
INTERN Memorandum of Understanding
Between
CSU Monterey Bay Internship Programs
And

SANTA CRUZ CITY SCHOOLS

Name of School/District

Beginning in Summer/Fall 2022, all Special Education Credential Programs in California are required to be in compliance with the new Clinical Practice requirements set by the Commission on Teacher Credentialing (CTC) for all Interns in Special Education Credential Programs (see [CTC Letter to Districts and County Offices of Education](#)). One of these requirements is that all Special Education Interns acquire at least 200 hours of Supervised Early Field Work in general and special education, under the supervision of a fully qualified district employed supervisor/master teacher. These 200 hours must be accumulated prior to the enrollment of an Intern in “final student teaching” (e.g., CSUMB’s Final Semester Practicum Course). Since CSUMB’s Special Education Intern Program is a two-year program, these 200 hours must be obtained in the first three semesters of the program.

By signing this agreement, the School agrees to:

- Provide release time for the Special Education Intern, at a minimum of 4 hours per week, to participate in Supervised Early Field Work in general education and special education elementary and secondary settings.
- Participate with the CSUMB Field Placement Coordinator and Special Education Program Coordinator to arrange for appropriate experiences in the school/district where Special Education Interns can complete their Supervised Early Field Work in general and special education elementary and secondary settings.

The CSU Monterey Bay Department of Education and Leadership agrees to:

- Authorize and monitor Supervised Early Field Work experiences in general and special education elementary and secondary settings to ensure the required 200 hours are acquired prior to the Special Education Intern’s enrollment in “final student teaching”.
- Provide Program Supervision (e.g., observations, opportunities for reflection, etc.) to Special Education Interns while engaged in Supervised Early Field Work in general and special education elementary and secondary settings.

School/District Administrator/Designee

324/713

Cathi Draper Rodriguez
Department Chair, College of



Commission on Teacher Credentialing

1900 Capitol Ave Sacramento, CA 95811 (916) 322-6253 Fax (916) 445-0800 www.ctc.ca.gov

Office of the Executive Director

Date: March 6, 2020

From: Mary Vixie Sandy, Executive Director, Commission on Teacher Credentialing

To: California TK-12 Districts and County Offices of Education

Re: Partnering with Educator Preparation Programs to Implement New Education Specialist Program Standards and Teaching Performance Expectations

Letter to Employers of Education Specialist Interns:

The purpose of this letter is to inform agencies that employ intern special education candidates of the significant upcoming changes to the California credentialing system for the preparation of special education teachers in California. These changes will impact employers in important and positive ways. Not only will candidates be prepared differently, but the credentials being issued to candidates will be different as well. These changes to the credentialing system now more than ever will require a close partnership between educator preparation institutions and their local employers.

Changes to the Credentialing System

By fall 2022 all educator preparation programs that prepare candidates for an Education Specialist credential will have transitioned to meet new program standards and prepare their candidates to meet the new [Education Specialist Teaching Performance Expectations](#). California's credentialing system will reflect these significant changes to candidate preparation with the new authorization statements that accompany the new credentials which candidates will receive upon successful completion of an Education Specialist preparation program. While this new credential structure will impact candidates who begin a preparation program as of the summer or fall 2022, it does not impact individuals who currently hold an Education Specialist credential. Existing Education Specialist Credential holders still hold valid credentials with authorization statements that state which students they are authorized to serve.

There will be five preliminary Education Specialist credentials issued in California after the summer/fall of 2022 when educator preparation programs are required to implement the new standards. Until appropriate regulations are approved, the existing Education Specialist credential structure consisting of seven credentials will continue to be granted to those who complete preparation programs.

Beginning in Fall 2022, and after approval of the associated regulations, the five new credentials will be:

- Mild to Moderate Support Needs
- Extensive Support Needs
- Early Childhood Special Education

- Visual Impairments

The significant changes identified above impact three of the five credentials listed. Both the Mild to Moderate Support Needs and the Extensive Support Needs credentials serve as cross-categorical credentials whereby candidates are prepared to serve students in all Federal disability categories with the exception of students who are deaf-blind. The idea is that it is the level of an individual student's need as determined by the student's Individualized Education Plan (IEP) that would dictate the services needed and the appropriate individual to provide those services. This means that both Mild to Moderate Support Needs candidates and Extensive Supports Needs candidates will be prepared to work with students identified with a range of disabilities. With respect to the changes to the Early Childhood Special Education credential, the authorization for this credential has been expanded so that holders of this credential will now be able to serve in a Kindergarten classroom. Given the larger scope of preparation for these candidates, employers of interns seeking education specialist credentials will want to partner with teacher preparation programs so that their employees/intern candidates are able to successfully meet the new program requirements and teaching performance expectations to complete the program and obtain their credential. Some of the specific changes to the program requirements will be explained further in this letter.

Clinical Practice/Field Experience Requirements for Candidates (including Interns) Seeking an Education Specialist Credential

In an effort to better prepare teachers for today's classrooms, the Commission on Teacher Credentialing has been revising the requirements for the Education Specialist credential. Part of this revision included expectations around the types of fieldwork that candidates would need to experience as part of their preparation. With the adoption of the new Preliminary Education Specialist Program Standards (2018), there are more stringent requirements around fieldwork for all candidates, including interns. The new program standards require that all candidates, including interns' "early field experience would take place in experienced mentor classrooms in both general education and special education settings." As the employing agency, local education agencies (LEAs) will want to have a reciprocal partnership with the institution (most often an institution of higher education) that has the approved teacher preparation program and is preparing the candidate (employee) to ensure that both the program and candidate requirements are fulfilled.

How the Commitment of District and County Offices of Education Assists in Candidate Completion of Credential Requirements

In accordance with the Commission's adopted Education Specialist Program Standards, "Candidates must have a range of experience that reflects the diversity of age and grade levels, the range of federal disability categories, and the continuum of special education services." As part of their fieldwork requirement, all candidates must have the experiences outlined above. Since intern candidates are employed by an LEA, it is critical to an intern's successful completion of the credential program that the employer assist the teacher preparation program to make the appropriate fieldwork obligations available to the intern either through

appropriate placements or by providing interns with sufficient release time so that they can meet their credential requirements.

Teaching Performance Assessment (TPA) for Education Specialist Credential Candidates

Another significant change to the educator preparation system in California for candidates seeking an Education Specialist credential is the requirement for each candidate to pass a teaching performance assessment, when it becomes available. The Commission has appointed a Design Team, with practitioners, teacher education faculty and other experts participating, to design a TPA appropriate for Education Specialist candidates. Opportunities to engage in a pilot year and field test year will be offered. This Teaching Performance Assessment (TPA) will require that Education Specialist credential candidates work with TK-12 students in classrooms across California, and to document these interactions by developing lesson plans, teaching and assessing students, (recording teaching practice and annotating the video as appropriate), collecting samples of student work, and reflecting on their practice. By the summer/fall of 2023, education specialist candidates will be required to complete and pass a CTC approved performance assessment to earn their preliminary teaching credential. Program supports will be offered through weekly office hours, monthly online learning communities, and in person trainings throughout the next two years. To learn more about the details for these supports, please see the PSD news published by the CTC every Friday online.

For more specific information about how programs in your area will be changing and how those changes will impact the new teachers and candidates employed by your district, we encourage you to meet with the Education Specialist teacher preparation programs in your area.

We look forward to strengthening and developing deeper collaborative relationships between Commission-approved teacher preparation programs and California schools, districts, and county offices of education. The shared commitment and responsibility of teacher preparation program sponsors, TK-12 school districts, county offices of education, and the Commission will lead to the successful implementation of mandatory credential requirements for candidates. The readiness of the incoming teaching workforce depends on the quality of these collaborative relationships. Thank you for your continued support.

PRACTICUM AGREEMENT
FOR FURNISHING FIELD TRAINING
FOR THE SCHOOL OF SOCIAL WORK

This Agreement is entered into between the Trustees of the California State University on behalf of San José State University, located at One Washington Square, San Jose, CA 95192 hereinafter called the (“the University”), and **Santa Cruz City Schools**, located at 133 Mission Street, Suite 100 Santa Cruz, CA 95060, hereinafter called the (“Facility”). The University and Facility are referred to collectively as the Parties.

Witnesseth:

WHEREAS, the Trustees have approved Bachelor of Arts in Social Work (“BASW”) and Masters of Social Work (“MSW”) Programs for the University and such programs require field work experience and the use of facilities; and

WHEREAS, it is to the mutual benefit of the parties hereto that students of the University’s Social Work Programs use facilities for their experience,

WHEREAS, the SOCIAL WORK PRACTICUM is an essential part of professional education for Social Work: an essential element of the practicum must be the inclusion of learning experiences that provide for students’ direct engagement in service activities. The intent of the Practicum is to enhance student learning within all areas of the curriculum. The Practicum should provide all students with opportunities for development, integration, and reinforcement of competence through performance in actual service situations. It should permit students to acquire and test skills relevant to emerging conditions of Social Work practice. The Practicum should also foster for all students the integration and reinforcement of knowledge, value and skill learning acquired through particular courses, with a focus on transcultural generalist practice and populations at-risk. In the Practicum the students should have an opportunity to delineate and comprehend questions for research which arise in the course of practice.

NOW, THEREFORE, in consideration of the covenants, conditions, and stipulations hereinafter expressed and in consideration of the mutual benefits to be derived therefrom, the parties hereto agree as follows:

I. FACILITY SHALL:

A. Permit each student who is designated by the University pursuant to Paragraph II. A below to receive field training experience at the Facility, and shall furnish, and permit such students and University instructors free access to appropriate facilities for field work experience.

B. It is expected, in accordance with the presently established values and goals of the University and School of Social Work, that placement facilities provide the following:

1. A field setting that offers the opportunity to serve various at-risk populations. This includes opportunities to work with clients who are oppressed, marginalized, and/or disenfranchised by virtue of their ethnicity, sexual orientation, socioeconomic status, immigration experience, age, and/or disability;

2. A setting that offers opportunities to students to examine their own commitment to these at-risk populations;
3. Setting that offers students opportunities to test, modify and integrate the ideas, concepts and values of the Social Work curriculum into their emerging professional selves; and
4. A setting that provides students with an opportunity to develop skills and practical knowledge by working with at-risk clients under the guidance of a skilled supervisor.

C. It is required that each Placement Facility shall:

1. Provide a learning experience that entails a commitment to service compatible with the values and ethics of the Social Work profession;
2. Provide a qualified field supervisor to be provided either by the agency or the School of Social Work. Assessment of qualifications will take into account professional education, commitment to the values of the Social Work profession, competence in practice, and interest and competence in teaching and supervising;
3. Accept the guiding principle that placement of not less than two (2) Social Work students is highly desirable from the educational perspective;
4. Make available suitable desk space, telephones, word processing facilities, supplies, transportation costs, clerical services and interviewing facilities. This provision may be waived under exceptional circumstances if the educational benefits resulting from a Practicum experience in a particular agency or setting could not be otherwise realized;
5. Provide sufficient structure for the necessary learning experience, i.e. acceptable field instruction, and proper assumption of responsibility by administration, staff, sponsor or constituency, when the Practicum is located in organizations in fields other than social welfare;
6. Provide periodic supervisory conferences and semester evaluations, and open communications between the setting, the field supervisor, and School must be satisfactorily met as spelled out by the School of Social Work in the Field Practicum Manual; and
7. Have the right, after consultation with the University, to refuse to accept for further experience any of the University's students who in the Facility's judgment are not participating satisfactorily in said program.
8. Facility is aware of and informed about the hazards currently known to be associated with the novel coronavirus referred to as "COVID-19". Facility is familiar with and informed about the Centers for Disease Control and Prevention ("CDC") current guidelines regarding COVID-19 as well as applicable federal, state, and local governmental directives regarding COVID-19. Facility, to the best of its knowledge and belief, is in compliance with those current CDC guidelines and applicable governmental directives. If the current CDC guidelines or applicable government directives are modified, changed or updated, Facility will take steps to comply with the modified, changed or updated guidelines or directives. If at any time, the Facility becomes aware that it is

not in compliance with CDC guidelines or an applicable governmental directive, it will notify the University of that fact.

II. TRUSTEES, THROUGH THE UNIVERSITY, SHALL:

- A. Designate the students who are enrolled in the San José State University's Practicum Programs of the School of Social Work to be assigned for field experience at the Facility, in such numbers as are mutually agreed to by both parties;
- B. Monitor all instruction for field work experience given at the Facility to the assigned students and provide the necessary Social Work instructor(s) when the Facility field supervisor is not a Social Worker;
- C. Keep all attendance and academic records of students participating in said Program;
- D. Require every student to conform to all applicable Facility policies, procedures, and restrictions specified jointly by representatives of the University and Facility; and
- E. Require University's School of Social Work instructors to notify Facility in advance of:
 - 1. Student(s) assigned to the facility.
 - 2. Student Schedules
 - 3. Changes in placement assignments

III. FACILITY AND UNIVERSITY SHALL AGREE AS FOLLOWS:

A. THIS AGREEMENT will become effective as of the date of the last executed signature and shall remain in effect for a term of five (5) years, unless terminated sooner. Either party, after giving the other party 30 days advance written notice of its intention to so terminate, or for just cause, this agreement can be terminated immediately by either party.

Should either party terminate this agreement for any reason, the terms of this Agreement may remain in full force for those existing Student Interns and Staff Interns still participating in SJSU's MSW program for as long as they are enrolled as students of SJSU, and the University is satisfied that the Facility meets the Field Placement requirements of the MSW Program.

B. In order to ensure the satisfaction of all, the student and the field supervisor must jointly formulate a practicum Contract to be submitted for approval by the Faculty Field Liaison and the Field Education Director of the BASW or MSW Program.

C. Mutual Indemnification

SJSU shall indemnify, defend, and hold harmless Facility, its officers, agents and employees from any claim, liability, loss, injury or damage arising out of the performance of this Agreement by

SJSU and/or its agents, employees or subcontractors, excepting only loss, injury or damage caused by the negligence or willful misconduct of personnel employed by the Facility. SJSU shall reimburse Facility for all costs, attorneys' fees, expenses and liabilities incurred with respect to any claim or litigation for which SJSU is obligated to indemnify, defend and hold harmless Facility under this Agreement.

Facility shall indemnify, defend and hold harmless SJSU, its officers, agents and employees from any claim, liability, loss, injury or damage arising out of the performance of this Agreement by Facility and/or its agents, employees, subcontractors, excepting only loss, injury or damage caused by the negligence or willful misconduct or personnel employed by the SJSU. Facility shall reimburse SJSU for all costs, attorneys' fees, expenses and liabilities incurred with respect to any claim or litigation for which Facility is obligated to indemnify, defend and hold harmless SJSU under this Agreement.

The parties shall cooperate with each other in the investigation and disposition of any claim arising out of the activities of this Agreement, provided that nothing shall require either party to disclose any documents, records or communications which are protected under the peer review privilege, the attorney-client privilege or the attorney work-product privilege. The provisions of this section shall survive the termination of this Agreement.

D. Insurance

Without limiting the indemnification of either party to this Agreement, each party shall maintain or cause to be maintained the following insurance coverage: (i) a policy of commercial general liability with limits of liability not less than two million dollars (\$2,000,000) per occurrence and four million dollars (\$4,000,000) annual aggregate; (ii) a policy of workers' compensation providing statutory coverage; and (iii) such other insurance or self-insurance as shall be necessary to insure it against any claim or claims for damages arising under the Agreement. Insurance afforded by the commercial general liability policy shall be endorsed to provide coverage to the other party of the Agreement as an additional insured. Each party to this Agreement shall provide a Certificate of Insurance certifying that coverage as required herein has been obtained. The requirements of this section may be satisfied by the provision of similar coverage through a self-insurance program.

E. Whole Agreement and Amendments. This Agreement contains the entire agreement between the Parties and shall not be modified, amended or supplemented, or any rights herein waived, unless such amendment or modification to this Agreement is (i) in writing; (ii) refers to this Agreement; and (iii) executed by an authorized representative of each Party. This Agreement supersedes any and all previous agreements, whether written or oral, between the Parties.

IN WITNESS WHEREOF, by signing below, each Party acknowledges its agreement with the terms and conditions of this Agreement and each signatory represents and warrants that he/she is authorized to sign on behalf of and to bind his/her Party to all of the terms and conditions of this Agreement.

FACILITY,

Agency Name Santa Cruz City Schools

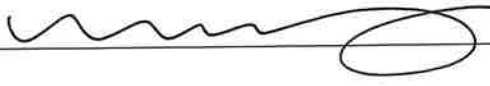
Authorized Signature 
Print Name Molly Parks
Title Assistant Superintendent of Human Resources
Date 1/3/22

SAN JOSE STATE UNIVERSITY, STRATEGIC SOURCING

San José State University

Authorized Signature

DocuSigned by:

0BD0C79CA107495...

Print Name Karen McCall

Title Lead Buyer

Date 1/10/2022

USC SCHOOL/SCHOOL DISTRICT PLACEMENT AGREEMENT

This School / School District Placement Agreement (“Agreement”) is made this 1st day of May, 2022 (the “Effective Date”), by and between Santa Cruz City Schools, with an address located at 133 Mission Street, Ste. 100, Santa Cruz, CA 95060 (“School” or “District”), and the University of Southern California, a California nonprofit educational institution, with an address of Waite Phillips Hall, 3551 Trousdale Parkway, ADM 352, Los Angeles, CA 90089 (“USC”). USC and School/District may be referred to collectively as the “parties” and individually as a “party.”

WHEREAS, USC offers graduate degree programs to its students (“Candidates”) in classroom and in online learning environments; and

WHEREAS, with respect to the online learning environment, USC Rossier offers graduate degree programs with an online learning component and field placement experiences (“Programs”), including, among others, Programs in the fields of teaching and school counseling.

NOW THEREFORE, intending to be legally bound hereby, the parties agree as follows:

1. Placements. The School/District agrees to host one or more Candidates in accordance with the terms of this Agreement and as further set forth in either: (a) the Teaching Candidate Addendum with respect to teaching Candidates; (b) the School Counseling Candidate Addendum with respect to School Counseling Candidates; or (c) such other addenda for such additional Programs as may be agreed upon by the parties from time to time. Each aforementioned Addendum (collectively, the “Addenda”) is incorporated into and made a part of this Agreement.

2. Placement Opportunities.

(a) USC will request placements for its Candidates for one or more of the Programs detailed in the Addenda. Each request shall identify the particular Candidate (or, for groups of Candidates, a composite description of relevant background, assignment request, assignment objectives and suggested activities as appropriate to requested assignments for the Candidate group). USC shall comply with any School/District policy applicable to such placement requests and provided by the School/District to USC.

(b) The School/District agrees to use good-faith efforts to place Candidates proposed by USC within the School/District. The School/District shall have the sole discretion with respect to all Candidate assignments hereunder, provided that the School/District shall involve USC throughout the decision-making process. The School/District shall not in any way be obligated to accept assignments of Candidates beyond the capabilities of the School/District, as determined by the School/District in its sole discretion. The School/District shall have the right to terminate its relationship with any Candidate for violation of the School’s/District’s regulations or for other reasonable cause in accordance with the School’s/District’s standard policies or practice.

3. Compliance with Law.

(a) *Background Investigations.* (i) USC shall inform each Candidate being hosted by the School/District that they are required to complete a background check and receive appropriate clearance(s) in accordance with applicable state and local law prior to commencing any assignment at the School/District (e.g., a State-issued Certificate of Clearance in the case of a teacher placement in California). (ii) The School/District may impose requirements upon Candidates in addition to those required by state law as set forth in Section 3(a)(i) above (the “Additional Requirements”). In such event, the School/District agrees to provide all such Additional Requirements in writing to USC promptly following execution of this Agreement (or, as applicable, promptly upon any adoption or modification thereof occurring during the Term of this Agreement). USC shall communicate all such Additional Requirements to Candidates, and shall advise Candidates to make any and all additionally required submissions directly to the School/District. Upon notice to the Candidate, the School/District shall have the right to reject any Candidate who fails to comply with the Additional Requirements from participating in an assignment at the School/District.

USC shall inform each Candidate being hosted by the School/District that they are required to complete a background check and receive appropriate clearance(s) in accordance with applicable state and local law prior to commencing any assignment at the School/District (e.g., a State-issued Certificate of Clearance in the case of a teacher placement in California). Santa Cruz City Schools will ensure that the candidate has valid fingerprint clearance as normally obtained through Certificate of Clearance prior to placement in schools and classes of the District for purposes outlined in this agreement. Santa Cruz City Schools will fingerprint each Candidate and complete the background check, unless USC has clearance information and is shared with the School/District. USC will immediately notify Santa Cruz City Schools of any Subsequent Arrest Notifications with Candidates working on Santa Cruz City Schools campuses when informed or aware of subsequent notices.

(b) *Tuberculosis Screening:* Students will provide evidence of proper tuberculosis screening prior to placement in schools and classes of the School/District for purposes outlined in this agreement. This screening evidence will include tuberculosis test results and dates of screening (to be completed within the previous 4 years). Otherwise, Santa Cruz City Schools will provide a tuberculosis self-assessment form to complete.

4. No Employment Relationship of Candidates.

(a) Candidates are students, and not employees of USC or the School/District. As such, they are not covered by USC's or the School's/District's workers' compensation policies.

(b) Candidates are neither entitled to, nor shall receive, any compensation or other employee-related benefit (without limitation) from USC or the School/District. Candidates shall not displace any School/District employee.

(c) The School/District shall provide in writing any requirements for Candidates to obtain and maintain personal liability insurance coverage, which requirements may vary based on the applicable Program. USC shall communicate to Candidates any such School/District coverage requirements, provide reasonable assistance to Candidates in obtaining such coverage, and facilitate each Candidate's submission of appropriate documentation thereof directly to the School/District (which the School/District agrees to accept).

5. Information, Hiring & Confidentiality.

(a) USC is a non-profit, educational research institution interested in evaluating the success of its graduates in impacting student achievement relative to comparable teachers, school counselors, or other appropriate position, as the case may be. As such, USC may request the School/District to provide information to assist USC in its evaluative process. If available, the School/District shall provide such information to USC following any such reasonable request.

(b) The School/District may hire any Candidate(s) upon program completion, but is under no obligation to do so.

(c) USC shall not request the School/District to provide any health or other records of any student of the School/District covered by the Family Educational Rights and Privacy Act ("FERPA"); nor shall USC request any Candidate to share any protected School/District data (whether about School/District students or personnel) with USC.

(d) To the extent that any party to this Agreement discloses any confidential information to any other party hereto in connection with the relationships contemplated hereunder, the parties agree during the term of this Agreement (and all renewals thereof) and for a period of two (2) years thereafter to use reasonable efforts to protect, maintain as confidential, and not disclose, any such confidential information of any other party.

6. Compliance with the Law. The parties hereto shall comply with all applicable federal, state and local laws, rules, statutes, acts, regulations, code and similar legal requirements, including but not limited to FERPA.

7. Non-Discrimination. Each party represents that it is an equal opportunity employer. Each party certifies that it does not, and shall not, discriminate against its employees, students, Candidates or applicants on any unlawful basis. Each party certifies that it is, and shall remain, in compliance with all laws, regulations, executive orders or other legal prohibitions against discrimination.

8. Indemnification.

(a) *Indemnification by School/District.* The School/District shall indemnify, defend and hold harmless USC, its employees, agents and representatives, from all claims, actions, awards or judgments for damages, including costs, expenses and attorneys' fees, where liability is found to exist by reason of the acts or omissions of the School/District, its employees, agents or representatives.

(b) *Indemnification by USC.* USC shall indemnify, defend and hold harmless the School/District, its employees, agents and representatives, from all claims, actions, awards or judgments for damages, including costs, expenses and attorneys' fees, where liability is found to exist by reason of the acts or omissions of USC, its employees, agents or representatives.

9. Governing Law. The interpretation, application, and enforcement of this Agreement shall be governed by the laws of the State of California without reference to choice of law principles. Any claim, suit, or cause of action involving the interpretation, application, or enforcement of this Agreement shall be commenced in the appropriate state or federal courts in the State of California.

10. Term, Termination and Renewal. The Term of this Agreement shall begin as of the later of the Effective Date or the date of the School's/District's signature set forth below ("Term Commencement Date") and continue through June 30th of the calendar year following the third anniversary of the Term Commencement Date. Unless any party terminates this Agreement pursuant to this Section 10, this Agreement shall automatically renew for successive one (1) year periods beginning each July 1st thereafter. Any party may terminate this Agreement with or without cause upon written notice to the other parties, provided that any such termination shall only be effective after the end of the school year during which the written notice of termination is issued. For the avoidance of doubt, other than where the School/District removes a Candidate pursuant to Section 2(b) above, the School/District shall permit current Candidates to complete the current school year at the time of any such termination.

11. Notices. Any notice to be given hereunder by any party to this Agreement shall be in writing and will be deemed given on the date received as evidenced by confirmation of receipt, except if such confirmation is later than 3:00 p.m. (School/District local time), addressed as follows (provided that, upon written notice in accordance herewith, any party may update its notice recipients at any time during the term of this Agreement):

(a) *If to the School/District* Santa Cruz City Schools, 133 Mission Street, Ste 100., Santa Cruz, CA 95060; attention Assistant Superintendent of Human Resources; Facsimile No. (831) 429-3433

(b) *If to USC:* University of Southern California, Rossier School of Education, Waite Phillips Hall, 3470 Trousdale Parkway, WPH-504G, Los Angeles, CA 90089; attention: Dr. Kathy Stowe, Associate Dean of Academic Programs; Facsimile No. (213) 740-5799.

12. Limitation of Liability. Except as such damages may be sought or assessed in respect to third party actions covered by the indemnification provisions herein, no party shall be liable to the other for consequential, incidental, indirect, exemplary, punitive or special damages of any nature or character (including loss of profits, data, business or goodwill or any indirect economic damages whatsoever), from causes of action of any kind, including contract, tort (including strict liability or other legal theory), a breach of any warranty or term of this agreement, or otherwise, even if the party at fault or in breach has been advised or had reason to know in advance of the possibility of incurring such damages.

13. Severability. In the event that any provision of this Agreement conflicts with the law under which this Agreement is to be construed or if any such provision is held invalid or unenforceable by a court with jurisdiction over the parties to this Agreement, such provision will be restated to reflect as nearly as possible the original intentions of the parties in accordance with applicable law; and the remaining terms, provisions, covenants, and restrictions of this Agreement will remain in full force and effect.



14. Entire Agreement/No Modification/Counterparts/Execution/Binding Agreement. This Agreement constitutes the entire agreement between the parties with respect to its subject matter, and fully supersedes and replaces any and all prior or contemporaneous understandings or agreements, written or oral, between the parties hereto or any of their respective affiliates regarding such subject matter. Any waiver, change in, amendment, addition, supplement or other modification of any provision of this Agreement will be valid and effective only if in writing and signed and dated by all parties hereto subsequent to the execution of this Agreement. This Agreement may be executed in any number of counterparts, each of which shall be deemed to be an original as against any party whose signature appears thereon, and all of which shall together constitute one and the same instrument. This Agreement shall become binding when one or more counterparts hereof, individually or taken together, bear the signatures of all of the parties reflected hereon as the signatories. A faxed, PDF or electronic signature shall have the same legally binding effect as an original signature. This Agreement will be binding upon the parties and their successors, affiliates, subsidiaries, assigns, officers, directors, employees, and agents. All continuing covenants, duties and obligations herein shall survive the expiration or earlier termination of this Agreement.

15. Arbitration. All controversies, claims and disputes arising in connection with this Agreement shall be settled by mutual consultation between the parties in good faith as promptly as possible, but failing an amicable settlement shall be settled finally by arbitration in accordance with the provisions of this paragraph. Such arbitration shall be conducted in Los Angeles, California, in accordance with the Commercial Arbitration Rules of the American Arbitration Association (“AAA”). The parties hereto hereby agree that the arbitration procedure provided for herein shall be the sole and exclusive method of resolving any and all of the aforesaid controversies, claims and disputes. The costs and expenses of the arbitration, including without limitation attorneys’ fees, shall be borne by the parties in the manner determined by the arbitrator. Legal action for (i) entry of judgment upon any arbitration award or (ii) adjudication of any controversy, claim or dispute arising from a breach or alleged breach of this paragraph may be heard and tried only in the courts of the State of California for the County of Los Angeles or the Federal District Court for the Central California for the County of Los Angeles or the Federal District Court for the Central District of California. Each of the parties hereto hereby irrevocably and unconditionally waives any right(s) to trial by jury in any action or proceeding arising under this Section 15 and each party further waives any defense of lack of in personam jurisdiction of said courts. Each party agrees that service of process in such action may be made upon each of them by mailing it certified or registered mail to the other party at the address provided for in this Agreement. Both parties agree that the prevailing party shall be entitled to recover from the non-prevailing party reasonable expenses, including without limitation, attorneys’ fees.

16. No Agency; No Assignment. Both parties acknowledge that they are independent contractors, and nothing contained herein shall be deemed to create an agency, joint venture, franchise, or partnership relation between the parties. Neither party hereto shall have the right, directly or indirectly, to assign, transfer, convey or encumber any of its rights under this Agreement without the prior written consent of the other party. Subject to the foregoing, this Agreement shall be binding upon and inure to the benefit of the respective successors and assigns of the parties.

INTENDING TO BE LEGALLY BOUND HEREBY, the parties affix their respective hands below:

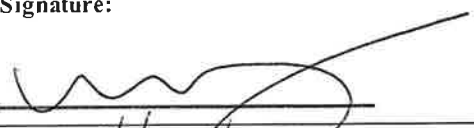
Santa Cruz City Schools	UNIVERSITY OF SOUTHERN CALIFORNIA, ON BEHALF OF THE USC ROSSIER SCHOOL OF EDUCATION
-------------------------	---

Print Name: <u>Molly Parks</u>	Print Name: <u>Michael Nichol</u>
Signature: 	Signature: 
Dated: <u>4/20/22</u>	Dated: <u>Apr 20, 2022</u>

**TEACHING CANDIDATE ADDENDUM
TO THE ROSSIER PLACEMENT AGREEMENT**

This Teaching Candidate Addendum to the School/School District Placement Agreement ("Addendum") is incorporated into and made a part of that certain School / School District Placement Agreement (the "Agreement") executed concurrently with this Addendum (or subsequently on the date indicated below), and is effective as of "Term Commencement Date", as defined in the Agreement. Capitalized terms not otherwise defined in this Addendum shall have the meaning ascribed to them in the Agreement.

1. Controlling Terms. The terms of this Addendum modify and supplement the Agreement. Whenever any inconsistency or conflict exists between the Agreement and this Addendum, the terms of this Addendum control and supersede the Agreement. In all other respects, the terms of the Agreement are ratified and confirmed.

2. Placement Opportunities. USC shall identify prospective Candidates to the School/District for potential placement within the School/District, including assignment to a teacher of record, in the following categories: (i) "Observation Students" (e.g., recess observation, lunchtime interactions, interactions with parents/teachers, etc.); (ii) "Research Students" (e.g., case study, classroom observation with student interaction, lesson delivery as part of fieldwork, etc.); and (iii) "Student Teachers" (i.e., "Guided Practice", with "Guiding Teachers", as defined in Section 3 below). USC shall supply the Candidate's name, relevant program and background clearance information and type of assignment appropriately matching the prospect's needs. Notwithstanding the foregoing, the School/District shall at all times have discretion over the maximum number of Candidates it shall accept as Observation Students, Research Students and Student Teachers, the length of assignments, and the distribution of assignments.

3. Guiding Teachers.
 - (a) The School/District shall make recommendations to USC regarding teachers whom it believes are appropriate to serve as Guiding Teachers (defined below). Through the School's/District's recommendations, USC's observations and Student Teacher reference, USC shall identify teachers working within the School/District to supervise and prepare Student Teachers during their student teaching experiences ("Guiding Teacher").

 - (b) Both the School/District and USC shall approve the participation of any teacher as a Guiding Teacher, provided that the School/District shall use its best efforts to approve a sufficient quantity of Guiding Teachers necessary to oversee the agreed-upon number of Student Teachers placed within the School/District at any time.

 - (c) Should any Guiding Teacher become unable to perform or fulfill his or her duties hereunder, the School/District shall assign an alternative Guiding Teacher to the Student Teacher (excluding a substitute teacher that replaces the original Guiding Teacher within the School/District).

4. Credential Seeking Candidates. Any credential seeking USC Student Teacher Candidate shall be required to sit for and pass applicable, state- and subject-specific exams (e.g., CSET, CBEST, etc.) prior to the commencement of his or her assignment as a Student Teacher.

5. Honorarium.
 - (a) Upon each Student Teacher's completion of his or her guided learning assignment, USC shall pay, or direct a designated third party to pay, an honorarium of \$350.00 directly to each Guiding Teacher for his or her participation in a Student Teacher's guided learning assignment. The School/District agrees that USC may require Guiding Teachers to submit reasonable documentation to USC prior to USC making payments hereunder.

 - (b) USC shall comply with any School/District policy requiring that the School/District, and not third parties, make Guiding Teacher payments to Guiding Teachers. In such event, the School/District may require USC

to make Guiding Teacher payments to the School/District for distribution by the School/District to Guiding Teachers, provided that the School/District shall first invoice USC for any such payment(s). For the avoidance of doubt, in the event that USC makes Guiding Teacher payments to the School/District in accordance with this Section 5(b), Section 5(a) above shall be deemed stricken from the Agreement with respect thereto.



(c) Should any Guiding Teacher fail to complete his or her assignment hereunder (either due to such teacher's own circumstances or due to USC's removal of the teacher as a Guiding Teacher), USC shall pay the corresponding honorarium on a pro rata basis.

(d) USC shall comply with any written School/District policy or procedure contrary to this Section 5, provided that the School/District shall provide any copy/copies thereof upon execution of the Agreement or subsequent adoption thereof.

6. Use of Video. USC utilizes video recording throughout its programs, including as an essential element of its instruction methodology. (By way of example only, the State of California requires USC to administer a Teaching Performance Assessment ("TPA") of its students as part of USC's teacher preparation program, with a component of that TPA being video that USC must obtain from each Student Teacher and maintain on file with the California Commission on Teacher Credentialing.) As such, any Student Teacher may make video recordings as part of his or her program studies throughout his or her assignment at the School/District. USC shall require Student Teachers to be responsible for obtaining appropriate and signed video release/authorization forms (which USC shall provide to Student Teacher) on behalf of recorded individuals, as appropriate, including obtaining parent/guardian signatures on behalf of recorded individuals who are minors (*i.e.*, under the age of legal competence). The School/District may provide reasonable assistance to Student Teachers in obtaining signatures on such forms.

7. Performance Data. Should the School/District hire any teacher Candidate(s), the School/District shall support USC's program evaluation initiatives by sharing student-level performance data for students he or she teaches to measure teacher efficiency relative to other Master of Arts in Teaching graduates and to other new teachers prepared through other pathways. USC shall keep such data confidential and use it only to facilitate analysis of its effectiveness, and will share its findings with the School/District. This paragraph 7 shall survive the expiration or termination of the Agreement for any reason.

INTENDING TO BE LEGALLY BOUND HEREBY, the parties affix their respective hands below:

Santa Cruz City Schools	UNIVERSITY OF SOUTHERN CALIFORNIA, ON BEHALF OF THE ROSSIER SCHOOL OF EDUCATION
Print Name: <u>Molly Parks</u>	Print Name: _____ Michael Nichol
Signature: 	Signature: 
Dated: <u>4/21/22</u>	Dated: <u>Apr 20, 2022</u>

**SCHOOL COUNSELING CANDIDATE ADDENDUM
TO THE ROSSIER PLACEMENT AGREEMENT**

This School Counseling Candidate Addendum to the School / School District Placement Agreement (“Addendum”) is incorporated into and made a part of that certain School / School District Placement Agreement (the “Agreement”) executed concurrently with this Addendum (or subsequently on the date indicated below), and is effective as of “Term Commencement Date”, as defined in the Agreement. Capitalized terms not otherwise defined in this Addendum shall have the meaning ascribed to them in the Agreement.

1. Controlling Terms. The terms of this Addendum modify and supplement the Agreement. Whenever any inconsistency or conflict exists between the Agreement and this Addendum, the terms of this Addendum control and supersede the Agreement. In all other respects, the terms of the Agreement are ratified and confirmed.

2. Placement Opportunities. USC shall identify prospective Candidates to the School/District for potential placement within the School/District, including assignment to a school-site supervisor of record. USC shall supply the Candidate’s name, relevant program and background clearance information and type of assignment appropriately matching the prospect’s needs. Notwithstanding the foregoing, the School/District shall at all times have discretion over the maximum number of Candidates it shall accept as School Counselor Students, the length of assignments, and the distribution of assignments.

3. School-site Supervisor.
 - (a) The School/District shall make recommendations to USC regarding [staff members] whom School/District believes are appropriate to serve as “School-site Supervisors” (defined below). Through the School’s/District’s recommendations, USC’s observations and School/District staff references, USC shall identify counselors and other staff working within the School/District to supervise and prepare School Counselor Candidates during their in-school experiences (“School-site Supervisors”).

 - (b) Both the School/District and USC shall approve the participation of any staff as a School-site Supervisor, provided that the School/District shall use its best efforts to approve a sufficient quantity of School-site Supervisors necessary to oversee the agreed-upon number of School Counselor Candidates placed within the School/District at any time.

 - (c) Should any School-site Supervisor become unable to perform or fulfill his or her duties hereunder, the School/District shall assign an alternative School-site Supervisor to the School Counselor Candidate (excluding a substitute teacher that replaces the original School-site Supervisor within the School/District).

4. Credential Seeking Candidates. Any credential seeking USC School Counselor Candidate shall be required to sit for and pass applicable, state-specific exams (*for example, in California, the California Basic Educational Skills Test*), as applicable in the Candidate’s state of residence, prior to the commencement of his or her assignment as a School Counselor Candidate.

5. Use of Audio. USC utilizes audio recording throughout its programs, including as an essential element of its instruction methodology. As such, any Candidate may make audio recordings as part of his or her program studies throughout his or her assignment at the School/District. USC shall require Candidates to be responsible for obtaining appropriate and signed audio release/authorization forms (which USC shall provide to Candidate) on behalf of recorded individuals, as appropriate, including obtaining parent/guardian signatures on behalf of recorded individuals who are minors (*i.e.*, under the age of legal competence). The School/District may provide reasonable assistance to Candidates in obtaining signatures on such forms.

6. Performance Data. Should the School/District hire any school counselor Candidate(s), the School/District shall support USC's program evaluation initiatives by sharing student-level performance data for students he or she counsels to measure school counselor efficiency relative to other Master of Education in School Counseling graduates and to other new school counselors prepared through other pathways. USC shall keep such data confidential and use it only to facilitate analysis of its effectiveness, and will share its findings with the School/District. This paragraph 6 shall survive the expiration or termination of the Agreement for any reason.

INTENDING TO BE LEGALLY BOUND HEREBY, the parties affix their respective hands below:

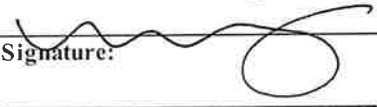
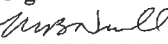
Santa Cruz City Schools	UNIVERSITY OF SOUTHERN CALIFORNIA, ON BEHALF OF THE ROSSIER SCHOOL OF EDUCATION
Print Name: <u>Molly Parks</u>	Print Name: _____ Michael Nichol
Signature: 	Signature: 
Dated: <u>4/21/22</u>	Dated: <u>Apr 20, 2022</u>



STUDENT TEACHER (PRACTICE TEACHING) AGREEMENT

This Student Teacher (Practice Teaching) Agreement (the “Agreement”) is made between Santa Cruz City School’s (the “District”) and The Regents of the University of California, on behalf of its Santa Cruz campus (the “University” or “UCSC”). The District and the University may hereinafter be referred to individually as a “Party”, and/or collectively as the “Parties”.

1. RECITALS

WHEREAS, The District is authorized to enter into agreements with the University, to provide teaching experience through Practice Teaching, as defined below, to students enrolled in teacher training curricula of the University; and

WHEREAS, pursuant to the provisions of the Education Code of the State of California, the governing board of any school district is authorized to enter into agreements with any institution approved by the Commission on Teacher Credentialing as a teacher education institution to provide teaching experience to students enrolled in the teacher training curricula of such institutions; and

WHEREAS, University is approved by the Commission on Teacher Credentialing as a teacher education institution.

NOW, THEREFORE, in consideration of the mutual promises and undertakings herein, the District and the University agree as follow:

2. DEFINITIONS

“Practice Teaching” as used herein and elsewhere in this Agreement means active participation in the duties and functions of classroom teaching under the direct supervision and instruction of employees of the District holding valid credentials issued by the California Commission on Teacher Credentialing, other than emergency or provisional credentials, authorizing them to serve as classroom teachers in the schools or classes in which the Practice Teaching is provided.

3. STATEMENT OF SERVICES AND REFUSAL OF SERVICES

Practice Teaching placements:

a. District shall provide to University students' Practice Teaching in schools and classes of the District under the direct supervision and instruction of such employees of the District, as the District through their authorized representatives, shall agree upon.

b. The District may, for good cause, refuse to accept for Practice Teaching any student of the University assigned to Practice Teaching in the District, and upon request of the District made for good cause, the University shall terminate the assignment of any student of the University to Practice Teaching in the District.

c. An assignment of a student of the University to Practice Teaching in the District shall be deemed to be effective for the purposes of this Agreement as of the date the student presents to the proper authorities of the District the Final Student Teacher Placement notice or other documents given to the student by the University effecting such assignment.

d. Student teachers are students of the University and not employees of the District.

e. The respective services and undertakings provided by a Party under this Agreement shall be at no cost to the other Party and shall not create any right in the providing Party to receive any monetary or other compensation from the other Party for any such services or undertakings.

4. UNIVERSITY REPRESENTATIONS

The University represents to the District that each student the University authorizes to participate in Practice Teaching in the District shall have received a fingerprint clearance from the Department of Justice ("DOJ") and the Federal Bureau of Investigation ("FBI") and received a tuberculosis test result showing that the student is free of infectious tuberculosis.

5. TERM

The term of this Agreement shall commence on August 2022 and continue through June 2025 unless modified as provided in Section 8 hereof. The term of this Agreement shall automatically renew for an additional term of three years after expiration of the initial term unless either Party notifies the other Party to the contrary within sixty (60) days prior to the end of the initial term.

6. INDEMNIFICATION

Each Party agrees to protect, hold harmless, indemnify and defend the other Party (including its respective officers, officials, employees, students and volunteers) from any and all liability (including reasonable attorney's fees) resulting from injury to or death sustained by any person or damage to property of any kind, that arises out of the performance of this Agreement, but only in proportion to and to the extent such liabilities are caused by or result from the respective negligent or intentional acts or omissions of a Party, its officers, employees, or agents.

7. INSURANCE

Each Party shall keep in full force and effect, during the term of this Agreement either through commercial insurance policies or self-insurance in the amounts determined in accordance with the respective policies of each Party.

8. NOTICES

All notices provided by one Party to the other Party shall be signed by the Party giving notice and shall be delivered to the other Party in one of the following manners: (a) by email to the other Party if the sender retains evidence of successful transmission; (b) by certified mail, return receipt requested; or (c) by expedited delivery via a nationally recognized courier service to the other Party's designated representatives and at the appropriate addresses as follows:

To University:

Cynthia Lewis, Professor and Chair
Education Department
University of California, Santa Cruz
1156 High Street
Santa Cruz, CA 95064
Email: cylewis@ucsc.edu

With copy to:

Soleste Hilberg, MA/Credential Program
Director
Education Department
University of California, Santa Cruz
1156 High Street
Santa Cruz, CA 95064
email: soleste@ucsc.edu

To District:

Superintendent's Office
Kris Munro, Superintendent
Santa Cruz City School's
133 Mission Street Suite 100
Santa Cruz, CA 95060

With copy to:

Name: Molly Parks
Title: Assistant Superintendent
Address: Santa Cruz City School's
133 Mission Street Suite 100
Santa Cruz, CA 95060
Phone number: (831) 429 3410
Email: mparks@sccs.net

9. MODIFICATION

No modification of the terms of this Agreement shall be valid unless in writing and executed by the duly authorized representative of each Party.

IN WITNESS WHEREOF, The District and the University have executed this Agreement as of the date last signed below.

The Regents of the University of California,
on behalf of its Santa Cruz

By:



Cynthia Lewis, Professor and Chair
Education Department

Date signed: 6/26

Santa Cruz City School's
Superintendent's Office

By:



Molly Parks, Assistant Superintendent of Human Resources

Date signed: 7/6/2022

WALDEN UNIVERSITY

U.S. FIELD SITE AFFILIATION AGREEMENT

THIS AGREEMENT (the "Agreement") is made and entered into as of the date of the final signature below by and between WALDEN UNIVERSITY, LLC, located at 100 Washington Avenue South, Suite 1210, Minneapolis, MN 55401 ("Walden") and Santa Cruz City Schools located at 133 Mission Street, Suite 100 Santa Cruz, CA 95060 ("Field Site").

RECITALS

WHEREAS, Walden offers undergraduate, graduate, and post-graduate programs in the fields of nursing, social work, counseling, psychology, health sciences, and interdisciplinary studies (the "Programs") and seeks to partner with field sites for educational field experiences for Walden students (the "Students");

WHEREAS, field experiences shall include the Field Site's student education program conducted at the Field Site ("Field Experience Program");

WHEREAS, the Field Site is willing to make available its educational and professional resources to such Students; and

WHEREAS, Walden and the Field Site mutually desire to contribute to the education and professional growth of Walden Students.

NOW, THEREFORE, in consideration of the mutual promises and covenants hereinafter set forth it is understood and agreed upon by the parties hereto, as follows:

I. TERM AND TERMINATION

This Agreement shall commence on January 10, 2022 (the "Effective Date") and shall continue for a period of five (5) years (the "Initial Term"). Upon expiration of the Initial Term of this Agreement, this Agreement and the Term shall renew for successive one (1) year periods (each a "Renewal Term"). Notwithstanding the foregoing, either party may terminate this Agreement for any reason or no reason, upon thirty (30) calendar days' prior written notice to the other party. In the event of termination or expiration of this Agreement before any participating Student(s) has completed the then-current term, such Student(s) shall be permitted to complete the then-current term subject to the applicable terms of this Agreement, which shall survive until the date of such completion.

II. WALDEN RESPONSIBILITIES

A. Walden shall be responsible for the assignment of Students to the Field Site. Walden agrees to refer to the Field Site only those Students who have completed the prerequisite course of study as determined by Walden.

WALDEN UNIVERSITY

B. Walden shall provide a field education coordinator (the "Walden Coordinator") who will act as a liaison between Walden and the Field Site and coordinate the Field Experience Program with the Field Site. The Walden Coordinator will be responsible for maintaining communication with the Field Site including, but not limited to:

(1) Confirming any contact information for Students to the Field Site Coordinator, as defined below, prior to the Student assignment; and

(2) Supplying the Field Site with information regarding each Student's current level of academic preparation as may be required by the Field Site.

C. Walden shall provide an instructor (the "Walden Supervisor") who will serve as the academic course instructor and field experience instructor for the educational experience. The Walden Supervisor will have responsibilities including, but not limited to:

(1) Communicating with the Field Site Supervisor relating to each Student's educational experience at the Field Site;

(2) Evaluating student academic and Field Site work relating to the educational experience at the Field Site.

Notwithstanding the foregoing, the parties understand that Walden is an online institution; therefore, there will be no on-site faculty presence from Walden on Field Site premises.

D. Walden shall provide the Field Site with information regarding the particular requirements relating to Field Experience Programs including required hours and supervision requirements.

E. Walden maintains student professional liability insurance with a single limit of no less than Two Million Dollars (\$2,000,000) per claim and Four Million Dollars (\$4,000,000) annual aggregate and general liability insurance with a single limit of no less than One Million Dollars (\$1,000,000) per occurrence and Two Million Dollars (\$2,000,000) annual aggregate, with umbrella liability coverage in amounts no less than One Million Dollars (\$1,000,000). Such general liability insurance policies shall provide additional coverage to Walden's Students. Walden shall provide the Field Site with proof of coverage upon request.

III. FIELD SITE RESPONSIBILITIES

A. When available, the Field Site shall assign a staff member to serve as the coordinator for the Field Experience Program at the Field Site (the "Field Site Coordinator"). The Field Site Coordinator shall be responsible for:

(1) Planning and coordinating the education arrangements between the Field Site, the Students and Walden;

(2) Serving as a liaison between the Field Site and Walden; and

WALDEN UNIVERSITY

(3) Developing and administering an orientation program for Student which will familiarize the Students with the Field Site and all applicable policies and procedures.

B. The Field Site shall assign a qualified staff member having the appropriate and required credentials to serve as the preceptor or supervisor (the "Field Site Supervisor") for each Student. The Field Site shall provide planned and regularly scheduled opportunities for educational supervision and consultation by the Field Site Supervisor. The Program requires supervision specifically by the Field Site Supervisor, and such supervision may not be delegated. Field Site Supervisors are responsible for providing, as applicable to the Program, role modeling, direct patient or client supervision, and professional interactions, and sharing expertise and experience. Field Site Supervisors are expected to voice concerns when student behaviors are in question or patient safety is of issue. Field Site Supervisors shall provide instruction and services in accordance with applicable laws and shall educate Students as to the requirements of the applicable laws. The Field Site Supervisor shall work with the Walden Supervisor to review and evaluate the Students in the Field Experience Program.

C. The Field Site shall provide learning experiences for the Students that are planned, organized and administered by qualified staff in accordance with mutually agreed upon educational objectives and guidelines.

D. Where applicable, the Field Site shall provide the Students with an orientation familiarizing students with all applicable State and Federal laws and regulations as they pertain to practice at the Field Site, which may include those pertaining to Standards for Privacy of Individually Identifiable Health Information (the "Privacy Rule") issued under the federal Health Insurance Portability and Accountability Act of 1996 ("HIPAA"), which govern the use and/or disclosure of individually identifiable health information.

E. The Field Site shall ensure that the Students practice within the guidelines of any applicable professional ethics codes. The Field Site shall provide resources to Students for exploring and resolving any ethical conflicts that may arise during field training.

F. The Field Site Supervisor shall complete, with the Walden Supervisor and Student, all written evaluations of the Students' performance according to the timeline established by Walden. Evaluations will be submitted to the Walden Coordinator.

G. The Field Site reserves the right to dismiss at any time any Student whose health condition, conduct or performance is a detriment to the Student's ability to successfully complete the Field Experience Program at the Field Site or jeopardizes the health, safety or well-being of any patients, clients or employees of the Field Site. The Field Site Coordinator or assigned Field Site Supervisor shall promptly notify the Walden Coordinator and/or Walden Supervisor of any problem or difficulty arising with a Student and a discussion shall be held either by telephone or in person to determine the appropriate course of action. The Field Site will, however, have final responsibility and authority to dismiss any Student from the Field Experience Program.

WALDEN UNIVERSITY

H. If available at the Field Site, the Field Site agrees to provide emergency health care services for Students for illnesses or injury on the same basis as that which is provided to Field Site employees. With the exception of emergency care, the Students are responsible for providing for their own medical care needs. In the event that Field Site does not have the resources to provide such emergency care, Field Site will refer such Students to the nearest emergency facility.

I. The Field Site shall ensure adequate workspace for the Students and shall permit the use of instructional resources such as the library, procedure manuals, and client records as required by the Field Experience Program. Field Site shall provide Students with training on Field Site safety protocols, as applicable, and provide prompt notice to Walden of any situation involving threatened hazards or harm that may adversely impact the health or safety of Students.

J. In the event that Field Site allows students to participate in activities that are conducted virtually outside of the Field Site's facilities, such as allowing virtual visits, telehealth services, or other activities that do not involve in-person interaction, Field Site acknowledges that Walden does not control the performance, reliability, or security of the devices or networks used by students for these activities and Field Site shall be responsible for ensuring that such devices or networks meet Field Site's requirements.

K. The Field Site maintains general and professional liability insurance (or comparable coverage under a program of self-insurance) for itself and its employees with a single limit of no less than One Million Dollars (\$1,000,000) per occurrence and Three Million Dollars (\$3,000,000) annual aggregate. The Field Site shall provide Walden with proof of coverage upon request.

To the extent that the Field Site is an entity governed by and/or operated through any state or federal agency or is provided liability coverage through statutory or tort law, then the foregoing paragraph shall not apply.

IV. STUDENT RESPONSIBILITIES

Walden shall inform Students that they are responsible for the following:

A. Students shall provide their own transportation to and from the Field Site as well as any meals or lodging required during the field experience.

B. Students shall agree to abide by the rules, regulations, policies and procedures of the Field Site as provided to the Students by the Field Site during their orientation at the Field Site and shall abide by the requirements of all applicable laws.

C. Students shall agree to comply with the Standards for Privacy of Individually Identifiable Health Information (the "Privacy Rule") issued under the federal Health Insurance Portability and Accountability Act of 1996 ("HIPAA"), which govern the use and/or disclosure of individually identifiable health information.

D. Students shall arrange for and provide to Field Site any required information including, but not limited to, criminal background checks, health information, verification of

WALDEN UNIVERSITY

certification and/or licensure, insurance information and information relating to participation in federally funded insurance programs.

E. Students shall be required to purchase and maintain a policy of professional liability insurance with a single limit of no less than One Million Dollars (\$1,000,000) per incident and Three Million Dollars (\$3,000,000) annual aggregate. Students shall provide the Field Site with proof of coverage upon request.

V. MUTUAL RESPONSIBILITIES

A. FERPA. For purposes of this Agreement, pursuant to the Family Educational Rights and Privacy Act of 1974 (“FERPA”), the parties acknowledge and agree that the Field Site has an educational interest in the educational records of the Student participating in the Program to the extent that access to those records is required by the Field Site in order to carry out the Field Experience Program. Field Site and Walden shall only disclose such educational records in compliance with FERPA.

B. HIPAA. The parties agree that, if the Field Site is a covered entity under HIPAA:

(1) to the extent that a Student is participating in the Field Experience Program:

(a) Student shall be considered part of the Field Site’s workforce for HIPAA compliance purposes in accordance with 45 CFR §160.103, but shall not otherwise be construed to be employees of the Field Site;

(b) Student shall receive training by the Field Site on, and subject to compliance with, all of Field Site’s privacy policies adopted pursuant to HIPAA; and

(c) Student shall not disclose any Protected Health Information, as that term is defined by 45 CFR §160.103, to which a Student has access through Field Experience Program participation that has not first been de-identified as provided in 45 CFR §164.514(a);

(2) Walden will never access or request to access any Protected Health Information held or collected by or on behalf of the Field Site that has not first been de-identified as provided in 45 CFR §164.514(a); and

(3) No services are being provided to the Field Site by Walden pursuant to this Agreement and therefore this Agreement does not create a “business associate” relationship as that term is defined in 45 CFR §160.103.

C. The Field Site and Walden will promote a coordinated effort by evaluating the Field Experience Program annually, planning for its continuous improvement, making such changes as are deemed advisable and discussing problems as they arise concerning this affiliation.

WALDEN UNIVERSITY

D. The parties agree that Students participating in the Field Experience Program are at all times acting as independent contractors and that Students are not and will not be considered employees of the Field Site or any of its subsidiaries or affiliates by virtue of a Student's participation in the Field Experience Program and shall not as a result of Student's participation in the Field Experience Program, be entitled to compensation, remuneration or benefits of any kind.

E. The Field Site and Walden agree that Students will have equal access to their respective programs and facilities without regard for gender identity, race, color, sex, age, religion or creed, marital status, disability, national or ethnic origin, socioeconomic status, veteran status, sexual orientation or other legally protected status. Field Site and Walden will comply with all applicable non-discrimination laws in providing services hereunder.

F. Field Site represents that it has policies in place that are consistent with applicable laws to prevent and report instances of sexual harassment, sexual discrimination, and sexual misconduct and it will comply with these policies during its participation in the Field Experience Program. In the event that Field Site does not have such policies in place, it shall abide by Walden's Code of Conduct located at <https://www.waldenu.edu/legal/student-safety-title-ix> with regard to Walden's Students.

G. The terms and conditions of this Agreement may be amended by written instrument executed by both parties.

H. This Agreement is nonexclusive. The Field Site and Walden reserve the right to enter into similar agreements with other institutions.

I. This Agreement shall be governed by the laws of the State of Minnesota.

J. Any notice required hereunder shall be sent by certified or registered mail, return receipt requested and shall be deemed given upon deposit thereof in the U.S. mail (postage prepaid). Notices to Walden shall be sent to the Walden Coordinator at Walden University, LLC; 100 Washington Avenue South, Suite 1210; Minneapolis, MN 55401; with a copy to: Walden University, LLC; Attention: Legal Department; 7065 Samuel Morse Drive; Columbia, MD 21046. Notices to Field Site shall be sent to Santa Cruz City Schools Human Resources Department at 133 Mission Street, Suite 100 Santa Cruz, CA 95060.

K. Each party agrees to indemnify, defend, and hold harmless the other from all losses or liabilities resulting from the negligence or willful misconduct of the indemnifying party and/or its employees or agents arising under this Agreement, except to the extent such losses or liabilities are caused by the indemnified party's negligence or willful misconduct.

L. This Agreement sets forth the entire understanding of the parties hereto and supersedes any and all prior agreements, arrangements and understandings, oral or written, of any nature whatsoever, between the parties with respect to the subject matter hereof. This Agreement and any amendments hereto may be executed in counterparts and all such counterparts taken together shall be deemed to constitute one and the same instrument. The parties agree that delivery of an executed counterpart signature hereof by facsimile transmission, or in "portable document

WALDEN UNIVERSITY

and pictorial appearance of a document, will have the same effect as physical delivery of the paper document bearing the original signature.

M. Each person signing this Agreement on behalf of a party represents to the other party that the execution and performance of this Agreement is duly authorized to sign this Agreement on behalf of the party and that this Agreement constitutes a valid and binding agreement of such party, enforceable according to its terms.

N. This Agreement will be binding upon and inure to the benefit of each of the parties, their successors, and assigns. Neither party may assign this Agreement or assign its rights or delegate its duties hereunder without the prior written consent of the other party (except in connection with a merger, sale of all or substantially all of a party's assets, or other form of corporate reorganization of that party) and any purported assignment in violation of this Section will be without force or effect.

IN WITNESS WHEREOF, the parties hereto have duly executed this Agreement, effective the date first above written:

WALDEN UNIVERSITY, LLC

FIELD SITE

By: _____
(signature)

By: 
(signature)

Name: _____
(Print name)

Name: Molly Parks
(Print name)

Title: _____

Title: Assistant Superintendent, Human Resources

Date: _____

Date: January 5, 2022

SANTA CRUZ CITY SCHOOLS DISTRICT

AGENDA ITEM: Monday.com Ltd.: Membership Renewal

MEETING DATE: August 17, 2022

FROM: Kris Munro, Superintendent

RECOMMENDATION:

Approve the membership contract with Monday.com for project management.

BACKGROUND:

Monday.com is a project management tool that enables organizations to manage tasks, projects, and teamwork. As of 2022, the company serves 130,000 organizations, including many non-technical organizations.

Staff began using this system fall of 2020. The tool effectively supports project management and accountability. The Santa Cruz City Schools central office team will continue to use this tool for interdepartmental collaboration and accountability. Teams will be able to streamline and control complex workflow and operations. Additionally, the district will use this platform to manage projects and communicate efficiently on collaborative tasks.

The membership contract includes user licenses, which will be used by cabinet, executive assistants, directors, and other central office staff.

FISCAL IMPACT:

\$7,680.00 LCFF Base (Unrestricted)

This work is in direct support of the following District goals and their corresponding metrics.

Goal #5: SCCS will maintain a balanced budget and efficient and effective management.

Sales Order for Santa Cruz City Schools



Thanks again for the opportunity to present this proposal. Below, please find our proposed solution and its expected business impact. We have also included our recommended implementation, training and pricing plans. I look forward to hearing from you. Please let me know if you have any questions.

Sincerely,
Amia Trujillo

About monday.com

monday.com is a Work OS, where teams plan, run and track their processes, projects, and everyday work seamlessly.

Teams can shape any workflow, code-free, within minutes, automate manual work and push projects forward, while connecting distributed teams and strengthening remote collaboration.

The platform's features include: customizable workflow templates, time tracking, automations, data dashboards, and integrations with popular tools. Thousands of companies around the world connect their teams on monday.com

Trusted by 130K+ customers, across 200+ industries, from 190+ countries



monday.com Ltd

6 Yitzhak Sadeh St., Tel-Aviv, Israel
 6777506, Israel
 Tel.: 077-3180262
 Fax: 077-3180262
 Company Number: 514744887

To: Curtis Gomez
Company Legal Name: Santa Cruz City Schools
Tax ID: 000
Billing Address:
 133 Mission St, Suite 100,
 Santa Cruz, California,95060,
 United States
Sales Rep: Amia Trujillo
 MO-106914

Sold-To Name: Santa Cruz City Schools
Sold-To Address:
 133 Mission St, Suite 100,
 Santa Cruz, California, 95060,
 United States

Order Date: Sep 1, 2022
Valid Date: Aug 30, 2022

Pricing Summary

Description	List Price	Seats	Duration	Plan Period	Start Date	End Date	Net Price
monday.com Work OS - Pro Plan	\$16.00	40	12	Yearly	Sep 1, 2022	Aug 31, 2023	\$7,680.00
Total List Price							\$7,680.00
Total Net Price							\$7,680.00

Activation Period: Sep 1, 2022 - Aug 31, 2023

Payment Terms: Net 30

If this Sales Order is not returned signed by Customer by Aug 30, 2022, this offer expires.

This SO does not reflect any applicable taxes that may arise as a result of this SO. If monday.com is registered to collect and remit such applicable taxes (e.g. sales tax, VAT, etc.) monday.com will set forth such taxes in the applicable invoice related to this SO. Customer hereby acknowledges and agrees that the shipping and billing information set forth in this SO may be relied upon by monday.com for purposes of calculating such taxes.

Purchase Order Form – monday.com services

This Sales Order form (the "Order") for monday.com services as described above (the "Services") is issued under and shall be governed by monday.com's Terms of Service available at: <https://monday.com/terms/tos> (the "Terms") and any addendum thereto entered into by the parties in writing ("Addendum"); however, if a SaaS agreement was signed by monday.com Ltd. and the customer identified above (the "Customer") in respect of the Services (the "Agreement") then the engagement hereunder shall be governed by the Agreement. This Order, Terms, Addendum and Agreement (as the case may be) and any exhibits or appendices referred therein, constitute the entire agreement by and between monday.com and Customer in respect of the provision of the Services. Any other arrangements, either oral or in writing, in respect of the Services shall have no force or effect.

Notwithstanding Section 1.2 ("Modification or Discontinuation of the Service") of the Terms, if monday.com adds, modifies or discontinues any feature, functionality or any other tool, within the Service and/or Sites, which materially adversely affects the core functionality of the Service and Customer's use of the Service, and, if such change is not cured by monday.com within 30 days as of having received notification thereof by Customer, then Customer shall be entitled to terminate the Terms within 30 days thereof. Section 21.3 ("Arbitration") of the Terms, shall be deleted in its entirety. Notwithstanding Section 11.6 ("Suspension") of the Terms, monday.com shall, to the extent legally permissible and practicable, notify Customer of the events giving rise to such suspension prior to such suspension. In the event of termination for cause by Customer under section 11.2(a) ("Termination for Cause") of the Terms, where monday.com fails to cure within the cure period stated therein, then Customer shall be entitled to receive a prorated refund of any prepaid Subscription Fees paid for the unused and unexpired portion remaining in the Subscription Term. Notwithstanding Section 22.5 ("Assignment") of the Terms, the Terms, and any and all rights and obligations thereunder, may be assigned by a party to its affiliate and/or successor entity or person, resulting from a merger, acquisition, or sale of all or substantially all of a party's assets or voting rights without the other party's prior written consent, except for an assignment to a competitor of the other party, and provided that such assigning party provides prompt written notice of such assignment to the other party and the respective assignee agrees, in writing, to assume all of the assigning party's rights and obligations under the Terms. Notwithstanding the below, the parties acknowledge and agree that this sales order is governed by the terms as amended by the Addendum to the monday.com Terms of Service entered into by and between monday.com Ltd. and

dated Jul 19, 2022. Notwithstanding anything set forth in Section 19 ("Modifications") of the Terms, if Customer promptly notifies monday.com that such change materially adversely affects its use of the Service, and, if such change is not cured by monday.com within thirty (30) days as of having received written notification from Customer, Customer shall be entitled to terminate this Agreement within thirty (30) days thereof. During the first annual renewal term(s) following the initial term set forth in this Sales Order, the annual per user (seat) price of the Service, provided that such is renewed on the same subscription tier and for at least the same number of users (seats) set forth in this Sales Order, will not increase by more than three percent (3%) over and above the then prior year's annual per user (seat) price.

Name:

Title:

Date:

Signature: 

- If you are exempt from paying sales tax please attach a tax exemption certificate in order for us to process the correct invoice
- If you require a purchase order number to be quoted on the invoice, please attach a copy of the Purchase Order.
- Please confirm the finance contact, preferably an accounts payable e-mail address, where invoices should be sent

SANTA CRUZ CITY SCHOOLS DISTRICT

AGENDA ITEM: Nasdaq Boardvantage Agreement Renewal

MEETING DATE: August 17, 2022

FROM: Kris Munro, Superintendent

RECOMMENDATION:

Approve the renewal agreement with Nasdaq Boardvantage.

BACKGROUND:

Since 2018 Santa Cruz City Schools has used Nasdaq Boardvantage to prepare, edit and publish all board meeting agendas and corresponding board books. The software provides a platform for staff to easily upload, edit, and consolidate board meeting agendas and supporting documents. Trustees are also able to view and take notes on the documents.

The attached agreement will renew the District's licenses with Nasdaq Boardvantage for another three years.

FISCAL IMPACT:

\$14,774.25 Annually LCFF Base (Unrestricted)

This work is in direct support of the following District goals and their corresponding metrics.

Goal #4: We will develop a highly collaborative, professional culture focused on supporting effective teaching.

Goal #5: SCCS will maintain a balanced budget and efficient and effective management.

Goal #6: SCCS will maintain strong communication and partnership with its diverse community.



SERVICE ORDER

Nasdaq Corporate Solutions, LLC
 ("Corporate Solutions")
 151 West 42nd Street
 New York, New York 10036
 United States

This service order (this "Service Order") is governed by the agreement listed below as "Agreement Number" (hereinafter, the "MSA"), which sets forth the terms and conditions under which Corporate Solutions shall provide Customer (as defined below) the services described herein ("Services"), regardless of whether the MSA was entered into by Corporate Solutions or one of its Affiliates. The MSA is made part of this Service Order and is incorporated by reference mutatis mutandis. In case of a conflict between a term in this Service Order and a term in the MSA, the term in this Service Order shall control. Additionally, this Service Order shall prevail over any of Customer's general terms and conditions that may be contained in a purchase order or other document provided by or on behalf of Customer, and Corporate Solutions' provisioning of the Services does not constitute acceptance of any of Customer's terms and conditions and does not serve to modify or amend this Service Order. For purposes of this Service Order, all references in the MSA to the provider of services to Customer are deemed to be references to the Corporate Solutions legal entity identified herein.

Quote Number	Q-00049046
Account Number	N-00193032
Sales Contact	Brian Friedman
Agreement Type	NASDAQ_03_17
Agreement Number	10058703
Initial Term months	36
Renewal Term(s) months	12
Cancellation Notice (days)	ninety (90)
Quote Creation Date	July 28, 2022

Customer Contracting Entity ("Customer")	Customer Billing Address
Santa Cruz City Schools 405 Old San Jose Road Soquel California 95073 United States	Santa Cruz City Schools 405 Old San Jose Road Soquel CA 95073 USA
Customer Contact	Billing Contact
Kris Munro kmunro@sccs.net	Alyssa Martinez alyssamartinez@sccs.net

Total Summary of Costs related to the Service Order	
Annual Recurring Total:	\$14,774.25
Annual Removals Total:	\$(14,774.33)

Recurring Products

Product Name	Billing Frequency	Quantity	Annual Unit Price	Currency	Annual Total
Nasdaq Boardvantage - Administrative User	Quarterly	6	\$887.88	USD	\$5,327.28

Subscription					
Nasdaq Boardvantage - User Subscription	Quarterly	13	\$726.69	USD	\$9,446.97

Annual Recurring Total: \$14,774.25

Recurring Removals

Product Name	Billing Frequency	Quantity	Annual Unit Price	Currency	Annual Total
Nasdaq Boardvantage - End User Subscription (Special Sector)	Quarterly	3	\$(727.00)	USD	\$(2,181.00)
Nasdaq Boardvantage - Administrative User Subscription (Special Sector)	Quarterly	1	\$(915.83)	USD	\$(915.83)
Nasdaq Boardvantage - Administrative User Subscription (Special Sector)	Quarterly	5	\$(882.30)	USD	\$(4,411.50)
Nasdaq Boardvantage - End User Subscription (Special Sector)	Quarterly	10	\$(726.60)	USD	\$(7,266.00)

Recurring Removals Total: \$(14,774.33)

STANDARD TERMS AND CONDITIONS

1. This quote is valid for thirty (30) days.
2. This Service Order is effective upon execution by the parties, and the Initial Term commences on June 22, 2023. If Customer modifies this Service Order, this Service Order shall be null and void unless Corporate Solutions accepts Customer's modifications in writing. The Initial Term and Renewal Term(s) are set out above and apply only to the recurring products listed above. For such recurring Services, this Service Order shall have an Initial Term and will automatically renew thereafter for successive Renewal Terms (if any), unless either party terminates this Service Order by providing the other party with written notice at least the number of days outlined in the Cancellation Notice box above prior to the end of the Initial Term or any Renewal Term, the end of such then current term to be the effective date of termination. The Initial Term and all Renewal Terms (if any) will constitute the "**Term**" of this Service Order.
3. Customer confirms, by signing below, that it has the necessary authority to enter into this Service Order on the terms and conditions set forth in the MSA.
4. The term of the MSA shall not expire prior to the expiration of this Service Order.
5. The net unit price displayed above is the net billable amount for the relevant Service listed in this Service Order. Customer may direct Corporate Solutions to issue invoices of any Service Fees, Additional Charges, or other costs (to the extent Customer shall bear such costs under the MSA and this Service Order) to a third party, such as an agent or a Customer Affiliate ("**Third Party Payor**"), and Customer shall ensure that such Third Party Payor pays any and all invoices for the Services as set out in this Service Order. Notwithstanding the foregoing, Customer shall remain fully liable for the payment of any Service Fees, Additional Charges, or other costs and Customer is subject to the remedies set out in the MSA and this Service Order in the event of any non-payment of any Service Fees, Additional Charges, or other costs, irrespective of whether or not such non-payment is by the fault of the Third Party Payor or Customer.
6. All payments are due within thirty (30) days of the invoice date. All invoices shall be deemed final and binding unless Customer provides Corporate Solutions notice of any alleged discrepancies no later than ten (10) days from the invoice date. A late fee of 1.50% per month or the highest lawful interest rate, whichever is lower, may be applied to all amounts not paid when due.
7. Tax.
 - a. Service Fees and Additional Charges do not include any sales tax, value added tax, goods and services tax, or any other tax (any "**Tax**"). Customer shall pay all Taxes applicable to the Services; provided, however, Corporate Solutions shall pay any personal property tax or income tax imposed on Corporate Solutions by the relevant tax authority in Corporate Solutions' tax jurisdiction to the extent such personal property tax and income tax are applicable to the Services. For the avoidance of doubt, any income tax imposed on Corporate Solutions pursuant to this Section does not include any Withholding Tax (as defined below), which will at all times be the responsibility of Customer.

- b. If Customer is based in the United States and is legally entitled to an exemption from any Tax, Customer is responsible for providing Corporate Solutions with a legally-sufficient tax exemption certificate, resale certificate, or a copy of the direct pay permit for each applicable taxing jurisdiction. Corporate Solutions shall apply the tax exemption to invoices generated after the date Corporate Solutions receives such documentation.
 - c. If Customer is required by applicable law to deduct or withhold any tax, charge, or assessment from amounts due to Corporate Solutions, including any additional surcharges (collectively, the “**Withholding Tax**”), Customer shall promptly notify Corporate Solutions of such Withholding Tax, and Customer shall have liability to pay such Withholding Tax. Customer shall increase amounts payable to Corporate Solutions as necessary so that the net amount actually received by Corporate Solutions after the deduction or withholding of the Withholding Tax is equal to one-hundred percent (100%) of the charges on this Service Order.
8. A mobile application may be available for the Service on the App Store® from Apple Inc. (or any similar mobile application marketplace), in which case Customer’s users may be required to accept the terms and conditions of an end user license agreement (a “**EULA**”) in order to download and use such application. If accepted by a Customer user, the terms of such EULA shall be deemed incorporated into this Service Order (in each case, as of such acceptance date with respect to such user) and Customer shall be responsible for such user’s compliance with the terms of the EULA; provided, however, that, in the event of a conflict between the EULA and this Service Order, the EULA shall control, but only in respect of the applicable user’s download and use of the mobile application. Customer may view Corporate Solutions’ mobile applications EULA terms at <https://www.nasdaq.com/third-party-terms> (or any successor hyperlink).
 9. After the Initial Term set forth above, Corporate Solutions may, effective on the first day of January each year, adjust, or change the basis for calculating, any Service Fees on not less than ninety (90) days’ prior notice to Customer. Customer may cancel the applicable Service if Corporate Solutions increases its Service Fees for such Service by more than 8% in any year. If Customer exercises this right to cancel, Customer must notify Corporate Solutions within thirty (30) days of the price increase notice. The applicable Service will be cancelled from the date on which the Service Fees would have increased.

PRODUCT NOTES

Applicable to all Services unless otherwise shown:

Nasdaq Boardvantage - End User Subscription (Special Sector)

Nasdaq Boardvantage - Administrative User Subscription (Special Sector)

Nasdaq Boardvantage - Administrative User Subscription

Nasdaq Boardvantage - User Subscription

1. Customer hereby grants Corporate Solutions and each of its Affiliates a non-exclusive, worldwide license, to process, store and display any Customer Data (as defined below) in the Service. Such license shall be sub-licensable by Corporate Solutions to the extent necessary to provide the Service and shall be assignable by Corporate Solutions to the extent that this Service Order is assignable or otherwise transferable by Corporate Solutions pursuant to the terms of the MSA and this Service Order.
2. “**Portal**” means Customer’s Nasdaq Board vantage portal to be created by Corporate Solutions and comprising a part of the Service. “**Customer Data**” means all data, information, and materials provided by Customer or any of its Users (as defined below) to Corporate Solutions or any of its agents. Customer Data includes data uploaded by or on behalf of Customer or any of its Users into the Portal “**Customer Uploaded Content**”, and data used for authentication purposes (for example: Customer name, Username and ID, group, and team space names) “**Customer Authentication Data**”.
3. “**Administrative User**” is a Service user appointed by Customer to receive various access and administrative rights to the Portal depending on such Service user’s Portal Administrator Role. “**Portal Administrator Role**” means each predefined configuration of access and administrative rights within the Service which can be assigned to an Administrative User. Portal Administrator Roles include the following: Company Owner, Site Administrator, Content Owner, Teamspace Owner, and Teamspace Administrator. A “**Standard User**” is a Service user appointed by Customer to access the Portal and use, print and view documents as determined by the Administrative User and collaborate with Administrative Users and other Standard Users. Administrative Users and Standard Users are also referred to herein as “**User**” and two more of them, “**Users**”. The Customer is fully responsible for all its Users adhering to the terms governing use of the Service. Customer may appoint Affiliates as Users provided that Customer does not exceed the Quantity Limits set forth in this Service Order. The term of each User subscription hereunder aligns with the term of this Service Order and is subject to the standard termination notice in the Cancellation Notice box above.
4. Administrative Users are able to purchase additional User subscriptions from within the Service, subject to Customer’s most recently contracted per User licensing rate plus, if applicable, any price increases or adjustments made thereafter. Upon the Administrative User’s acceptance of the terms and conditions governing the purchase of additional User subscriptions within the Service, the order will be instantly fulfilled. To the extent Customer already has available contracted User subscriptions, Customer will not be charged for added User subscriptions. The additional purchased User subscriptions will be effective on the date they are added by an Administrative User (the “**Add User Effective Date**”), and have an initial term from the Add User Effective Date through the Renewal Date of the then-current Service Order (the “**Add User Initial Term**”). Thereafter, the Add User Initial Term shall renew for the term indicated as the Renewal Term in the then-current Service Order. Corporate Solutions will prorate the annual recurring total for the additional User subscriptions for the Add User Initial Term, if the Add User Initial Term is less than the then-current Initial Term or Renewal Term. An online service order for the additional User subscriptions will be sent

electronically to Customer to be executed by Customer's authorized signatory. If Customer fails to return the online service order signed and accept as-is within thirty (30) days of the date of the online service order, Corporate Solutions will cancel the online service order and revoke the additional Users without notice or liability. Customer's account representative may assist with questions about the process.

5. Customer shall ensure its use of the Service(s) conforms to the total quantity of User subscriptions purchased pursuant to this Service Order (the "**Quantity Limits**"). If Customer exceeds the Quantity Limits, Corporate Solutions may (for up to thirty (30) days) work with Customer to seek to reduce Customer's usage so that it conforms to such Quantity Limits. If, notwithstanding Corporate Solutions' efforts, Customer does not abide by the Quantity Limits, Customer will execute a Service Order or amendment for additional quantities of the Services promptly upon Corporate Solutions' request, and pay any subsequent additional fees for such additional quantities of User subscriptions.
6. Customer Uploaded Content is stored by Corporate Solutions on the servers within the Service Region (as defined below) where Customer has chosen to implement the Portal. "**Service Region**" means each set of geographical locations where the primary and secondary data centers storing Customer Uploaded Content are located. Customer Authentication Data is transferred to and stored in the Corporate Solutions' authentication module in the United States to verify entitlement of Users. Corporate Solutions has a global support team. As such, support may be provided by individuals located globally and certain Customer Authentication Data may be provided to the global support team to verify entitlement of Users, identify the requestor, and assist with resolution of the support request.
7. In connection with the Services, Customer shall not, and shall not knowingly permit any User or third party to, directly or indirectly, send, receive, upload, download, use or re-use any information or material that: (a) is abusive, indecent, defamatory, obscene or menacing, in breach of confidence or a violation of privacy, copyright or any other third party rights, laws or regulations; or (b) constitutes unsolicited advertising, commercial material, or promotional material under applicable law and/or regulation. In no event shall Customer upload into the Services, or use the Services to process, any information intended to further an illegal purpose. Customer may upload to its Portal or cause Corporate Solutions or its agents to create, receive, process, maintain or transmit any of the following types of data only to the extent the terms of the MSA and this Service Order provide sufficient protection (as determined by the Customer) for such types of data, or otherwise agreed to in a separate written agreement between Corporate Solutions and Customer: (A) personal data ("**personal data**" shall be deemed to have the meaning given to it in the General Data Protection Regulation (Regulation (EU) 2016/679)); and (B) information requiring specific data security or data protection measures by law or applicable industry practice. Corporate Solutions reserves the right, in its sole discretion, not to perform Services involving the creation, receipt, processing, storage or transmission of data requiring specific data security or data protection measures and such refusal shall not be deemed a breach of any of Corporate Solutions' obligations under this Service Order.
8. The Services (and certain associated software applications) may contain third-party open-source components ("**Open Source Components**"), which are provided under their applicable open source licenses ("**Open Source Licenses**"). A list of such Open-Source Components, along with their applicable Open-Source Licenses and associated notices, is available at https://www.nasdaq.com/docs/2021/01/07/2020-11-NBV-FOSS-LIST_NBV.pdf (or as otherwise made available by Corporate Solutions).
9. Customer is responsible for removal (downloading) of any Customer Uploaded Content uploaded by Customer or its User into the Service. This may be done by the Customer at any point prior to termination of the Service.

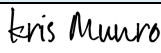
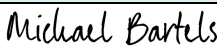
Signed on behalf of Santa Cruz City Schools		Signed on behalf of Nasdaq Corporate Solutions, LLC	
	DocuSigned by:		DocuSigned by:
Signature		Signature	
Print Name	5CD2A984F55A421...	Print Name	6BC5ED974C644B5...
Position		Position	
Date		Date	

SANTA CRUZ CITY SCHOOL DISTRICT

AGENDA ITEM: American Modular Systems Change Order #3 for Gault Elementary School Modular Classroom Building

MEETING DATE: August 17, 2022

FROM: Jim Monreal, Assistant Superintendent, Business Services

THROUGH: Kris Munro, Superintendent

RECOMMENDATION:

Ratify American Modular Systems change order #3 for Gault Elementary School modular classroom building.

BACKGROUND:

This change order consists of upgraded material costs and additional structural calculations and design as required by the Division of State Architect. The previously approved contract amount was \$5,227,183.00 and the new total contract, including this change order, will be \$5,249,963.00. This issue arose over the summer break and required immediate action.

FISCAL IMPACT:

Change Order #3 \$22,780.00 (0.43% increase to the contract), Measure B Funds (Restricted)

This work is in direct support of the following District goals and their corresponding metrics:

Goal #2: SCCS will create positive, engaging school environments that promote the development of cognitive skills and the social emotional well-being of all students.

Goal #5: SCCS will maintain a balanced budget and efficient and effective management.

Goal #6: SCCS will maintain strong communication and partnership with its diverse community.

Prepared by Trevor Miller, Director, Facility Services

AGENDA ITEM: 8.3.1.

CHANGE ORDER FORM

Santa Cruz City Schools
133 Mission Street, Suite 100
Santa Cruz, CA 95060

CHANGE ORDER NO.:
3

CHANGE ORDER

Project: Gault Elementary School Classroom Building

The following parties agree to the terms of this Change Order:

Owner:
Santa Cruz City Schools
133 Mission St., Suite 100
Santa Cruz, Ca 95060

Contractor:
American Modular Systems
787 Spreckles Ave
Manteca, CA 95336

Reference	Description	Cost	Days Ext.
PCO # 14	Material Changes	\$ 10,580.00	0
PCO # 15	DSA required Engineering for A3 Occupancy	\$ 12,200.00	0
Original Contract Amount:		\$ 4,840,520.00	
Amount of Previously Approved Change Order(s):		\$ 386,663.00	
Amount of this Change Order:		\$ 22,780.00	
Contract Amount:		\$ 5,249,963.00	

The undersigned Contractor approves the foregoing as to the changes, if any, and the Cost, if any, specified for each item and as to the extension of time allowed, if any, for completion of the entire work as stated therein, and agrees to furnish all labor, materials and services and perform all work necessary to complete any additional work specified for the consideration stated therein.

This change order is subject to approval by the governing board of this district and must be signed by the District.

The compensation and time, if any, granted herein represent a full accord and satisfaction for any and all time and cost impacts of the items herein, and Contractor waives any and all further compensation or time extension based on the items herein. The value of the extra work or changes expressly includes any and all of the Contractors costs and expenses, both direct and indirect, resulting from additional time required on the project or resulting from delay to the project. Any costs, expenses, damages or time extensions not included are deemed waived.

Signatures:

District:

[Name] _____
8/1/22
Date

Contractor:

[Name] Daniel Surich
07-29-2022
Date

END OF DOCUMENT

SANTÁ CRUZ CITY SCHOOL DISTRICT

CHANGE ORDER FORM



To: American Modular Systems
 787 Spreckels Ave.
 Manteca, CA 95336
 (209) 825-1921

Change Order #: 14

Initiation Date: _____

AMS Project 1657-21

Customer: Santa Cruz City Schools
 Site Address: 405 Old San Jose Road
 Santa Cruz, CA 95073

Project Site Gault ES

Change initiated by: Color Selections in Submittal Process

AMS is directed to make the following changes in the contract:

In the color submittal process, SCCS selected some colors that are not standard, are new products all together or changed the finishes. This PCO reflects those changes.

- 1) Change flooring in MPR from VCT to LVT in MPR VCT Cost, \$1.38/sf, 2880sf **\$ (3,974.40)**
 LVT Cost, \$3.68/sf, 2,880 \$ 10,598.40
 - 2) Change FRP material from white to medium grey White, \$0.69/sf, 2,800sf **\$ (1,932.00)**
 Grey, \$1.02/sf, 2,800sf \$ 2,856.00
 - 3) Change folding partition wall finish, see quote attached \$ 1,507.00
- 15% MU \$ 1,358.25
 1.6% Bond \$ 166.61

If we do not place the order on the folding partition wall by Tuesday May 24, 10am there will be an additional \$1,400 charge to this PCO.

The contract sum will be **increased** by this change order: \$ 10,580

The contract time will be **unchanged** by: _____ days.

New project completion date: na

American Modular Systems

By: Erica Moreno
 Director of Business Development
 Date: 5/20/22

Owner or Owner Representative

By: [Signature]
 Title: _____
 Date: 05/23/22

Note: All conditions and terms of the contract order will apply except as herein changed.



May 19, 2022

AMS
Attention: Matthew Reichmuth
787 Spreckels Avenue
Manteca, CA 95336

RE: Gault ES – REV 4
1320 Seabright Ave, 1st Floor
Santa Cruz, CA 95062

Dear Matthew:

Partition Specialties, Inc. (PSI) proposes to furnish labor and materials for the above referenced project according to the scope of work as outlined below. This scope of work is based on **Partial Plans Dated 01-06-2022** and **Specification Section Keynote 33 pg A1.0** dated **01-06-2022**, addenda 0 included. Plans provided were sheets A1.0, A4.0B, A8.3, S5.0, S5.1, S7.0, S9.1 and S9.2 only.

We propose to furnish quantities listed for the sum of (including applicable taxes):

Scope of Work:

Modernfold

- Model: Acousti-Seal Premier 47 STC, #17 track and trolleys with vinyl finish.
 - **Gypsum Board skin underneath the fabric finish**
 - **PSI's work must be completed prior to June 30, 2022**
- One (1) opening(s) with size to be 37'-6" w x 9'-0" h in MultiPurpose Rooms 7/8.
 - See attached preliminary sketches for layout and design, labeled OP-01-A1 for more information
 - This is the minimum number of panels required to fit the opening.
 - Finishes have a surface burn characteristic of a Class A finish.
 - The underlying panels are not 1-hour fire rated.
- Modernfold has begun to charge a freight crating surcharge since our previous quote on April 6th, so the price above has been adjusted to reflect that surcharge.

Alternates:

1. **In lieu of a standard Modernfold vinyl finish, provide Koroseal Spellbound Apollo (8821-03) COM vinyl finish** **ADD \$ 924.00**
2. If additional panels are required, that is an option **ADD \$ T.B.D.**
 - a. The number of additional panels will affect the price
 - b. Any increase in the number of panels will affect the pocket size. It would be able to get smaller in width, but each panel would add to the pocket's depth.
3. Modernfold does offer a fire rated operable partition in this line, if required **ADD \$ T.B.D.**
 - a. Please inquire about pricing if required.
4. **Add for labor cost increase on July 1, 2022.** **ADD \$ 583.00**
 - a. **Anticipated labor rate increase from the Union takes effect on July 1, 2022.**
5. **Anticipated escalation increase from Modernfold if the project is backlogged on/after June 1, 2022** **ADD \$ 1,200.00**
 - a. **This rate increase can be avoided if PSI is released by 5/24/22 or sooner.**

Clarifications:

- See the track layout of OP-01 for the number and location of the threaded rod drops.
- Due to the fire wall being built between the operable partition's track and the WFB above, PSI must install the threaded rod drops and track before the fire wall is installed See Details A/S7.0, 2/S7.0 and 1/A8.3.
 - Pre-drilled holes in the WFB for the threaded rod drops need to be provided by others prior to our arrival to install the track.
- PSI has a concern regarding an acoustical barrier not being shown above the operable partition which may allow for flanking sound to pass over the top of the operable partition.
 - Located above the ceiling, but below the fire wall.
- Price is based upon a 2 phase installation, Phase 1 - installation of track and field dimensions. Phase 2 - installation of panels.
- Please allow 2-3 weeks from PSI's receipt of approved submittals, for installation of the track and field dimensions.

March 9, 2022

AMS

Gault ES

Page 1 of 4



SPACE DIVISION



ACOUSTIC PRIVACY



WORKSPACE FLEXIBILITY



SUSTAINABILITY



DESIGN + AESTHETICS



- Please allow 8-10 weeks after field dimensions and color selection for panel installation.
 - Lead times are subject to change at the time the order is released for fabrication by the factory.
- Unless otherwise noted, price is based on installation during normal working hours.
- Price is based on PSI having clear access to work.
- Track attachment to steel or wood beam (supplied by others) is based on Modernfold standard details with a 4.5" maximum rod length.
- Stocking to work area is based on adequate freight elevator availability without elevator downtime.
- Bid is based upon standard product construction and finishes unless otherwise noted.
- COM finishes are factory applied and must be factory approved prior to application.
- Required Pocket Dimensions may vary from construction drawing set and should only be built AFTER operable wall submittals are approved so required dimensions can be verified.
- Operable wall being provided will meet STC requirements defined in product specification. However, surrounding construction (by others) may cause unwanted sound transmission from one side of a barrier to the other and should be built according to ASTM E557-12 or later construction standards, including the installation of a sound baffle and acoustical floor break, as required.
- PSI will furnish shop drawings and header details in accordance with Modernfold specifications showing all track bracket placements.
- PSI requires written Notification of Owner Controlled Insurance Requirements and Liquidated Damages. Participation in OCIP or CCIP is subject to policy review and PSI acceptance.
- All applicable taxes will be adjusted accordingly should Partition Specialties, Inc. responsibilities change for the above referenced project at a later date.

Exclusions:

Structural support, structural engineering, design build insurance, lateral bracing, trapezing or strut assemblies to avoid obstructions, punching or drilling header to receive threaded rods, welding, embeddings, x-ray or scanning of deck, stocking by crane, hazardous materials abatement/mitigation, backing at jambs, sweep contact blocking, ceiling work and sound baffling, repair to monocoat and drywall, pocket doors, pass door(s), high and low voltage electrical wiring and connections, final cleaning, field sound testing, wood trim at header or jambs, plan check, permits, overtime, extended warranty, warranty on finishes, on site video of demonstration, special inspections, testing costs and fees, BIM, local hire requirements, apprentice hire requirements, onsite owner training, special accounting or billing software fees.

A change in the price of an item of material, labor, equipment, fuel or any other component of this bid proposal of more than 5% between the date of bid proposal and the date of installation shall warrant an equitable adjustment in the subcontract price.

This proposal is based exclusively on our interpretation of project requirements. If plans or written specifications are found to conflict with our product as quoted or our interpretation, the right to change our proposed price is reserved. This proposal is expressly conditioned upon review, acceptance and execution of acceptable contract documents, including but not limited to, an achievable schedule for delivery and continuous uninterrupted work flow during regular business hours.

This proposal remains in effect for thirty days unless otherwise noted. Our terms are net thirty days and subject to credit approval. Following credit review, PSI may request a cash deposit prior to material procurement or installation. This proposal is subject to our terms and conditions. If you do not have a copy of the terms and conditions, please contact us and a copy will be sent to you. All of the terms in this proposal shall be deemed accepted by Partition Specialties, Inc. commencing work, the issuance of a letter of intent, or any instructions to Partition Specialties, Inc. to proceed with work by the Purchaser.

The above is our quotation of prices. If this meets with your approval, please indicate your acceptance by signing below.

Thank you for the opportunity to quote this project. If we can be of any further assistance please contact us.

Sincerely,

David Oberquell

20996 Cabot Blvd
Hayward, CA 94545
Phone: (510) 266-8247
Fax: (510) 293-9947
Email: doberquell@psi3g.com



To: American Modular Systems
787 Spreckels Ave.
Manteca, CA 95336
(209) 825-1921

Change Order #: 15
Initiation Date: _____

AMS Project 1657-21

Customer: Santa Cruz City Schools
Site Address: 405 Old San Jose Road
Santa Cruz, CA 95073

Project Site Gault ES

Change initiated by: DSA

AMS is directed to make the following changes in the contract:

DSA is requiring the MPR to be an A-3 occupancy, necessitating a 100ln floor. This PCO is for the engineering and calculating the new loads and impact on the concrete foundation.

Additional Calculations & Design by Structural Engineer \$ 7,600.00

Bid Item#268, Contract & Project Management, \$230/hr, 20 hours \$ 4,600.00
AMS scope of work is drafting time, detailing, etc for plan prep.

Upon approval of cost, engineering will take approximately 3 weeks.
Overall schedule to be examined.

The contract sum will be **increased** by this change order: \$ \$ 12,200

The contract time will be **increased** by: TBD days.

New project completion date: na

American Modular Systems

Owner or Owner Representative

By: Erica Moreno
Director of Business Development
Date: 6/28/22

By: _____
Title _____
Date: _____

Note: All conditions and terms of the contract order will apply except as herein changed.

AMERICAN MODULAR SYSTEMS (AMS) IS AN EQUAL OPPORTUNITY AND AFFIRMATIVE ACTION EMPLOYER. WE ARE COMMITTED TO DIVERSITY AND INCLUSION IN OUR WORKPLACE. WE ENCOURAGE ALL QUALIFIED INDIVIDUALS TO APPLY. WE WILL ACCEPT AND SUPPORT THE EMPLOYMENT OF ALL INDIVIDUALS WITHOUT REGARD TO RACE, ETHNICITY, GENDER, SEX, AGE, RELIGION, NATIONAL ORIGIN, ANCESTRY, DISABILITY, SEXUAL ORIENTATION, OR MARITAL STATUS. THIS POLICY APPLIES TO ALL EMPLOYEES AND APPLICANTS. AMERICAN MODULAR SYSTEMS (AMS) IS AN EQUAL OPPORTUNITY AND AFFIRMATIVE ACTION EMPLOYER. WE ARE COMMITTED TO DIVERSITY AND INCLUSION IN OUR WORKPLACE. WE ENCOURAGE ALL QUALIFIED INDIVIDUALS TO APPLY. WE WILL ACCEPT AND SUPPORT THE EMPLOYMENT OF ALL INDIVIDUALS WITHOUT REGARD TO RACE, ETHNICITY, GENDER, SEX, AGE, RELIGION, NATIONAL ORIGIN, ANCESTRY, DISABILITY, SEXUAL ORIENTATION, OR MARITAL STATUS. THIS POLICY APPLIES TO ALL EMPLOYEES AND APPLICANTS.

FORM
 120' x 40'
 2-STORY BUILDING
 SITE SPECIFIC PROJECT NAME
 SANTA CRUZ CITY SCHOOLS
 GAULT
 ELEMENTARY SCHOOL



MANUFACTURED PROFESSIONAL OF RECORD

DATE	
SCALE	
DRAWN BY	
APP'D BY	
CHECKED BY	
DATE	
SCALE	
DRAWN BY	
APP'D BY	
CHECKED BY	
DATE	

FLOOR FRAMING PLAN

SHEET NUMBER **S2.0**

- 1 FLOOR BEAM PER SHEET S2.0
- 2 HSS COLUMN PER SHEET S2.0
- 3 2" LIGHT WEIGHT CONCRETE FILL w/ 6600psi AWT 4 WWF (SEE NOTE 3 FOR TOTAL THICKNESS). SEE AISC 13 FOR DECK PROPERTIES, ATTACHMENT PATTERN, AND TEMPORARY SHORING REQUIREMENTS.
- 4 OPTIONAL BLOCK-OUT PER S2.1

Verify if wall create openings occur at 2nd floor, provide and coordinate for opening details and connection details in general.

KEY NOTES

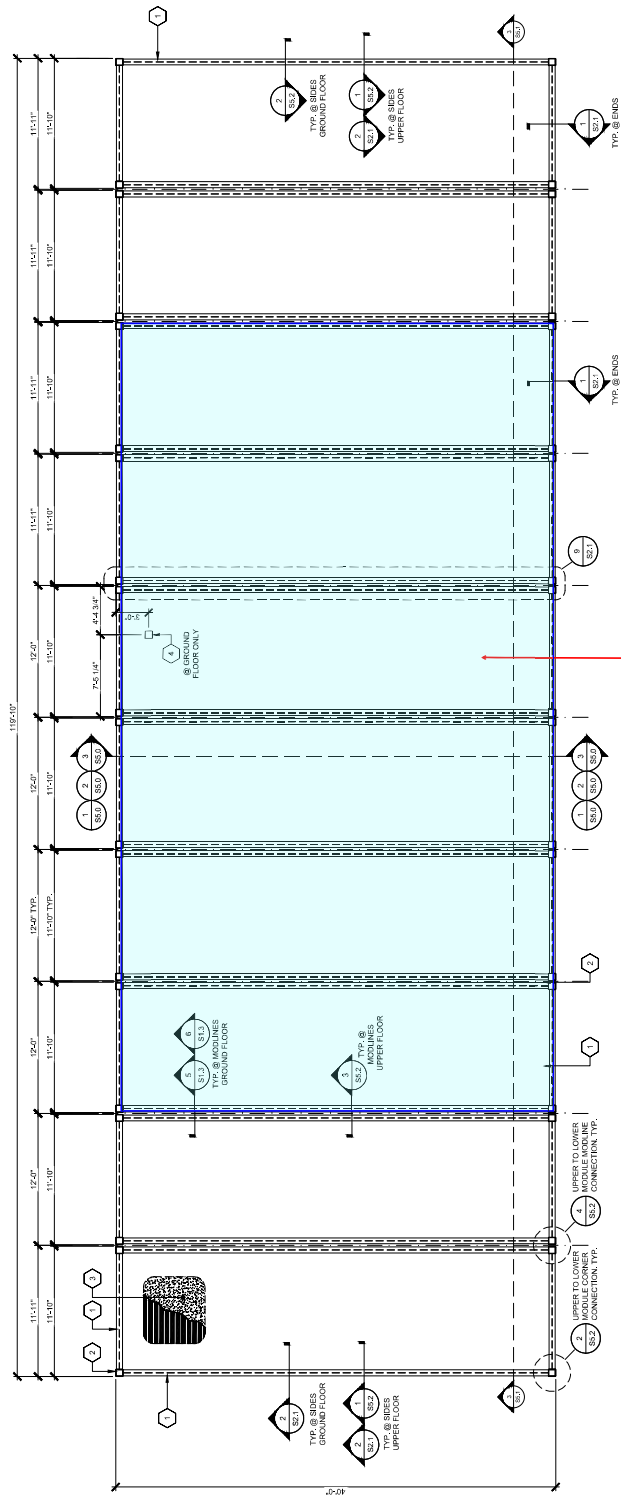



11590 W Bernardo Court
 Suite 100
 San Diego, CA 92127

Change Order

Date: 6/24/2022
Document # CO 01
PO #

Bill To:
 American Modular Systems
 787 Sprekles Ave.
 Manteca, CA 95336

Ship To
 RST 21137
 Gault HS - 2-Story Project

Contract Price	Change Order #1	Change Order #2	Change Order #3	Change Order #4	Revised Contract Price

Description	Est. Hours/Qty.	Rate	Total
Change Order 100 PSF Floor Revision		7,600.00	7,600.00

This Change Order is to authorize the additional fee for the Scope of Work and Project referenced above. All terms and conditions remain the same per the original Professional Services Agreement.

Approved by: _____ Signature: _____ Date: _____	Total	\$7,600.00
---	--------------	------------

SANTA CRUZ CITY SCHOOL DISTRICT

AGENDA ITEM: Atlantis Paving & Grading Change Order #1 for Bay View Elementary School Site Work

MEETING DATE: August 17, 2022

FROM: Jim Monreal, Assistant Superintendent, Business Services

THROUGH: Kris Munro, Superintendent

RECOMMENDATION:

Approve Atlantis Paving & Grading change order #1 for Bay View Elementary School site work.

BACKGROUND:

This change order consists of needed patching and repairs which were identified when the portable buildings were removed. The additional fencing was required adjacent to the Westside Parent Education Nursery School where an existing fence was damaged. The previously approved contract amount was \$147,899.00 and the new total contract, including this change order, will be \$210,878.65.

FISCAL IMPACT:

Change Order #1 \$62,979.65 (42.58% increase to the contract), Measure B Funds (Restricted)

This work is in direct support of the following District goals and their corresponding metrics:

Goal #2: SCCS will create positive, engaging school environments that promote the development of cognitive skills and the social emotional well-being of all students.

Goal #5: SCCS will maintain a balanced budget and efficient and effective management.

Goal #6: SCCS will maintain strong communication and partnership with its diverse community.

Prepared by Trevor Miller, Director, Facility Services

AIA Document G701 - 2017

Change Order

PROJECT: *(Name and address)*
Bay View Elementary School
Play Yard Site Work
1231 Bay Street.
Santa Cruz, CA

CONTRACT INFORMATION:
Contract For: General
Construction

Date: July 29th, 2022

CHANGE ORDER INFORMATION:
Change Order Number: 001

Date: July 29th, 2022

OWNER: *(Name and address)*
Santa Cruz City Schools
133 Mission St, Suite 100,
Santa Cruz, CA 95060

ARCHITECT: *(Name and address)*
Francis Chan
19six Architects Inc., 303 Potrero Street,
Suite 5, Santa Cruz, CA 95060

CONTRACTOR: *(Name and address)*
Atlantis Paving and Grading
PO Box 67453, Scotts Valley,
CA 95066

THE CONTRACT IS CHANGED AS FOLLOWS:

*Underground Survey Work
Utility removal and asphalt patchback
Additional fencing*

The original Contract Price was	<u>\$ 147,899.00</u>
The net change by previously authorized Change Orders	<u>\$ 00.00</u>
The Contract Price prior to this Change Order was	<u>\$ 147,899.00</u>
The Contract Price will be increased by this Change Order in the amount of	<u>\$ 62,979.65</u>
The new Guaranteed Maximum Price including this Change Order will be	<u>\$ 210,878.65</u>

The Contract Time will be increased by Zero (0) days.
The new date of Substantial Completion will remain July 29th, 2022

NOTE: This Change Order does not include adjustments to the Contract Sum or Guaranteed Maximum Price, or the Contract Time, that have been authorized by Construction Change Directive until the cost and time have been agreed upon by both the Owner and Contractor, in which case a Change Order is executed to supersede the Construction Change Directive.

NOT VALID UNTIL SIGNED BY THE ARCHITECT, CONTRACTOR AND OWNER.

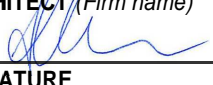
19six Architects, Inc.
ARCHITECT *(Firm name)*

SIGNATURE
Andrew Fullerton - Project Manager
PRINTED NAME AND TITLE
7/29/2022
DATE

Atlantis Paving & Grading
CONTRACTOR *(Firm name)*

SIGNATURE
Ryan Rittenhouse/CEO President
PRINTED NAME AND TITLE
7/29/2022
DATE

Santa Cruz City Schools
OWNER *(Firm name)*
SIGNATURE
PRINTED NAME AND TITLE
DATE

Job#J5595
Bay View Play Yard Resurfacing at Bay View Elementary School
Atlantis Paving & Grading
1231 Bay St. Santa Cruz CA 95060



Change Order 1

Description: Cost of Bess Testlab Inc. to locate and mark utilities at 1231 Bay Street, Santa Cruz. Image attached for reference.

Total Price: \$2,900.00

Authorized Signature:  Andrew Fullerton - MAD119six Date: _____
06/20/2022

- 7 - Sitework, Fencing Chainlink - 188 LF
- 43 - Concrete, Sealcoat - 58,091 SF

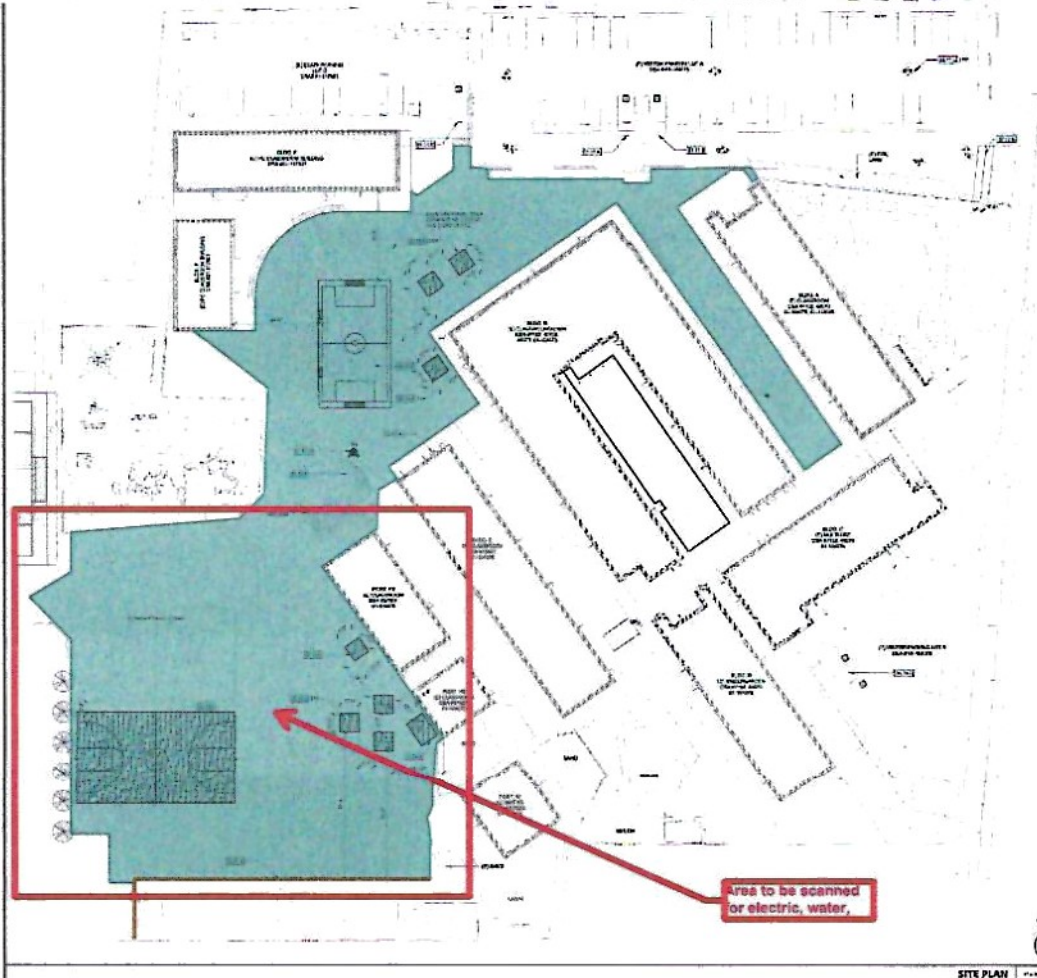

KEYNOTES

- 1. ALL WORK SHALL BE IN ACCORDANCE WITH THE STANDARD SPECIFICATIONS FOR PUBLIC WORKS, LATEST EDITION, AS APPLICABLE.
- 2. ALL MATERIALS SHALL BE OF THE BEST QUALITY AVAILABLE AND SHALL BE SUBJECT TO INSPECTION AND APPROVAL BY THE ENGINEER.
- 3. ALL WORK SHALL BE COMPLETED WITHIN THE SPECIFIED TIME FRAME.
- 4. THE CONTRACTOR SHALL BE RESPONSIBLE FOR OBTAINING ALL NECESSARY PERMITS AND APPROVALS.
- 5. THE CONTRACTOR SHALL MAINTAIN ACCESS TO ALL ADJACENT PROPERTIES AT ALL TIMES.
- 6. ALL UTILITIES SHALL BE LOCATED AND MARKED PRIOR TO CONSTRUCTION.
- 7. THE CONTRACTOR SHALL BE RESPONSIBLE FOR PROTECTING ALL UTILITIES AND STRUCTURES TO REMAIN.
- 8. ALL WORK SHALL BE COMPLETED IN ACCORDANCE WITH THE SPECIFICATIONS AND SHALL BE SUBJECT TO INSPECTION AND APPROVAL BY THE ENGINEER.
- 9. THE CONTRACTOR SHALL MAINTAIN ACCESS TO ALL ADJACENT PROPERTIES AT ALL TIMES.
- 10. ALL UTILITIES SHALL BE LOCATED AND MARKED PRIOR TO CONSTRUCTION.
- 11. THE CONTRACTOR SHALL BE RESPONSIBLE FOR PROTECTING ALL UTILITIES AND STRUCTURES TO REMAIN.
- 12. ALL WORK SHALL BE COMPLETED WITHIN THE SPECIFIED TIME FRAME.
- 13. THE CONTRACTOR SHALL MAINTAIN ACCESS TO ALL ADJACENT PROPERTIES AT ALL TIMES.
- 14. ALL UTILITIES SHALL BE LOCATED AND MARKED PRIOR TO CONSTRUCTION.
- 15. THE CONTRACTOR SHALL BE RESPONSIBLE FOR PROTECTING ALL UTILITIES AND STRUCTURES TO REMAIN.

SITE PLAN LEGEND

- EXISTING IMPROVEMENTS
- PROPOSED IMPROVEMENTS
- AREA OF PUBLIC INTEREST
- AREA OF PRIVATE INTEREST
- EXISTING UTILITIES
- PROPOSED UTILITIES
- EXISTING STRUCTURES
- PROPOSED STRUCTURES

NOTES

1. THE CONTRACTOR SHALL BE RESPONSIBLE FOR OBTAINING ALL NECESSARY PERMITS AND APPROVALS.
2. ALL MATERIALS SHALL BE OF THE BEST QUALITY AVAILABLE AND SHALL BE SUBJECT TO INSPECTION AND APPROVAL BY THE ENGINEER.
3. ALL WORK SHALL BE COMPLETED WITHIN THE SPECIFIED TIME FRAME.
4. THE CONTRACTOR SHALL MAINTAIN ACCESS TO ALL ADJACENT PROPERTIES AT ALL TIMES.
5. ALL UTILITIES SHALL BE LOCATED AND MARKED PRIOR TO CONSTRUCTION.
6. THE CONTRACTOR SHALL BE RESPONSIBLE FOR PROTECTING ALL UTILITIES AND STRUCTURES TO REMAIN.
7. ALL WORK SHALL BE COMPLETED WITHIN THE SPECIFIED TIME FRAME.
8. THE CONTRACTOR SHALL MAINTAIN ACCESS TO ALL ADJACENT PROPERTIES AT ALL TIMES.
9. ALL UTILITIES SHALL BE LOCATED AND MARKED PRIOR TO CONSTRUCTION.
10. THE CONTRACTOR SHALL BE RESPONSIBLE FOR PROTECTING ALL UTILITIES AND STRUCTURES TO REMAIN.
11. ALL WORK SHALL BE COMPLETED WITHIN THE SPECIFIED TIME FRAME.
12. THE CONTRACTOR SHALL MAINTAIN ACCESS TO ALL ADJACENT PROPERTIES AT ALL TIMES.
13. ALL UTILITIES SHALL BE LOCATED AND MARKED PRIOR TO CONSTRUCTION.
14. THE CONTRACTOR SHALL BE RESPONSIBLE FOR PROTECTING ALL UTILITIES AND STRUCTURES TO REMAIN.
15. ALL WORK SHALL BE COMPLETED WITHIN THE SPECIFIED TIME FRAME.

SITE PLAN SPECIAL NOTES

1. THE CONTRACTOR SHALL BE RESPONSIBLE FOR OBTAINING ALL NECESSARY PERMITS AND APPROVALS.
2. ALL MATERIALS SHALL BE OF THE BEST QUALITY AVAILABLE AND SHALL BE SUBJECT TO INSPECTION AND APPROVAL BY THE ENGINEER.
3. ALL WORK SHALL BE COMPLETED WITHIN THE SPECIFIED TIME FRAME.
4. THE CONTRACTOR SHALL MAINTAIN ACCESS TO ALL ADJACENT PROPERTIES AT ALL TIMES.
5. ALL UTILITIES SHALL BE LOCATED AND MARKED PRIOR TO CONSTRUCTION.
6. THE CONTRACTOR SHALL BE RESPONSIBLE FOR PROTECTING ALL UTILITIES AND STRUCTURES TO REMAIN.
7. ALL WORK SHALL BE COMPLETED WITHIN THE SPECIFIED TIME FRAME.
8. THE CONTRACTOR SHALL MAINTAIN ACCESS TO ALL ADJACENT PROPERTIES AT ALL TIMES.
9. ALL UTILITIES SHALL BE LOCATED AND MARKED PRIOR TO CONSTRUCTION.
10. THE CONTRACTOR SHALL BE RESPONSIBLE FOR PROTECTING ALL UTILITIES AND STRUCTURES TO REMAIN.
11. ALL WORK SHALL BE COMPLETED WITHIN THE SPECIFIED TIME FRAME.
12. THE CONTRACTOR SHALL MAINTAIN ACCESS TO ALL ADJACENT PROPERTIES AT ALL TIMES.
13. ALL UTILITIES SHALL BE LOCATED AND MARKED PRIOR TO CONSTRUCTION.
14. THE CONTRACTOR SHALL BE RESPONSIBLE FOR PROTECTING ALL UTILITIES AND STRUCTURES TO REMAIN.
15. ALL WORK SHALL BE COMPLETED WITHIN THE SPECIFIED TIME FRAME.

AREA TO BE SCANNED FOR ELECTRIC, WATER,

196

SANTA CRUZ CITY SCHOOLS
133 MISSION ST.
SANTA CRUZ, CA 95071

BAY VIEW ES SITE WORK
1231 Bay St.
Santa Cruz, CA 95010

SITE PLAN

A-101

A-101 - SITE PLAN.tif (26% of Scale); Takeoff in Active Area: All Areas; Bay View Play Yard Resurfacing at - COPS22-01508; OST Projects; 6/15/2022 10:37 AM



Change Order 2

Description: Demolish and patch approximately 24 areas of HMA that need to be replaced. Patch back and compact approximately 30 tons of new HMA in approximately 24 locations per layout. Includes cut/cap of approximately utility conduits in patch areas.

Total Price:

\$52,544.19

Andrew Fullerton - MADI19six

Authorized Signature: 07/13/2022

Date: _____

Bay View Play Yard Resurfacing at Bay View Elementary School - Change Order 2 - T&M Template - 6-28-2022/28/2022

Labor & Supervision

	Hours	Rate		Total	Total	Total
		Wages	Fringes			
Public Labor; ST	192	\$ 35.00	\$ 49.68	\$ 6,720.00	\$ 9,538.56	\$ 16,258.56
Public Labor; OT	0	\$ 52.50	\$ 51.98	\$ -	\$ -	\$ -
Public Labor; DT	0	\$ 70.00	\$ 53.63	\$ -	\$ -	\$ -
Public Supv; ST	64	\$ 40.00	\$ 50.68	\$ 2,560.00	\$ 3,243.52	\$ 5,803.52
Public Supv; OT	0	\$ 60.00	\$ 52.98	\$ -	\$ -	\$ -
Public Supv; DT	0	\$ 80.00	\$ 54.63	\$ -	\$ -	\$ -
Public Labor; ST		\$ 35.00	\$ 49.68	\$ -	\$ -	\$ -
Public Labor; OT	0	\$ 52.50	\$ 51.98	\$ -	\$ -	\$ -
Public Labor; DT	0	\$ 70.00	\$ 53.63	\$ -	\$ -	\$ -
Public Supv; ST		\$ 40.00	\$ 50.68	\$ -	\$ -	\$ -
Public Supv; OT	0	\$ 60.00	\$ 52.98	\$ -	\$ -	\$ -
Public Supv; DT	0	\$ 80.00	\$ 54.63	\$ -	\$ -	\$ -
Superintendent	5	\$ 110.00		\$ 550.00	\$ -	\$ 550.00
Project Manager	5	\$ 120.00		\$ 600.00	\$ -	\$ 600.00

Sub-Total 256 \$ 10,430.00 \$ 12,782.08 \$ 23,212.08

Workmans Comp 256 \$ 5.82 \$ 1,489.92

Mobilization & Transportation

Equipment Staging & Delivery	Hour	\$ 48.91		\$ -		
	Ea	\$ -		\$ -		
	Ea	\$ -		\$ -		
	Ea	\$ -		\$ -		
Equipment Truck	Miles	\$ 1.10	128	\$ 140.80		
Concrete Service Truck	Miles	\$ 1.90		\$ -		
Dump Truck (12.5 Ton)	Miles	\$ 1.90	160	\$ 304.00		
Sub-Total (Mobilization & Transportation)				\$ 140.80		\$ 140.80

Sub-Total Equipment (see Equipment & Material Summary) \$ 14,363.80

Sub-Total Materials (see Equipment & Material Summary) \$ 4,384.00

Sub-Total Subs & Vendors (see Equipment & Material Summary) \$ -

Disposal

	Bins	\$ -		\$ -		
	Cu Yd	\$ -		\$ -		
Waste Transport & Disposal (Const Debris)	Cu Yard	\$ 35.00		\$ -		
Waste Transport & Disposal (Concrete/HMA)	Cu Yard	\$ 70.00	30	\$ 2,100.00		
	Ea	\$ 90.00		\$ -		
	Ea	\$ 40.00		\$ -		
Sub-Total (Disposal)				\$ 2,100.00		\$ 2,100.00

Total Costs \$ 45,690.60

OH & Profit 15% \$ 6,853.59

Bonding 0% \$ -

Total T&M Billing \$ 52,544.19

Equipment Materials

Equipment	Day Rate	# Units										Total	\$ Extended
		TBD	TBD	TBD	TBD	TBD	TBD	TBD	TBD	TBD	TBD		
	\$ -											0	\$ -
	\$ -											0	\$ -
	\$ -											0	\$ -
	\$ -											0	\$ -
	\$ -											0	\$ -
	\$ -											0	\$ -
	\$ -											0	\$ -
	\$ -											0	\$ -
	\$ -											0	\$ -
	\$ -											0	\$ -
	\$ -											0	\$ -
	\$ -											0	\$ -
Air Compressor, diesel	\$ 269.00	1	1	1	1	1						5	\$ 1,345
Air Cooler	\$ 30.00											0	\$ -
Concrete, electric heavy hammer	\$ 98.00											0	\$ -
Concrete, pneumatic rivet buster	\$ 125.00	1	1	1	1	1						5	\$ 625
Concrete, flat saw, electric	\$ 250.00											0	\$ -
Concrete, flat saw, gas	\$ 200.00											0	\$ -
Concrete, Core Drill	\$ 125.00											0	\$ -
Concrete, cut off saw	\$ 150.00											0	\$ -
Concrete, ring saw	\$ 250.00	2	2	2	2	2						10	\$ 2,500
Concrete, Chain Saw	\$ 350.00											0	\$ -
Concrete, Jumping Jack	\$ 85.00						1	1	1			3	\$ 255
Electrical, 10 GA extension cords	\$ 10.65											0	\$ -
Electrical, 6 GA distribution cords	\$ 12.00											0	\$ -
Electrical, Power Box's	\$ 45.00											0	\$ -
Electrical,45 KW generator	\$ 300.00											0	\$ -
	\$ -											0	\$ -
	\$ -											0	\$ -
Heavy Eqpt, Excavator	\$ 750.00											0	\$ -
Heavy Eqpt, Skid Steer	\$ 350.00	1	1	1	1	1	1	1	1	1		8	\$ 2,800
Heavy Eqpt,Skip Loader	\$ 450.00											0	\$ -
Heavy Eqpt, Paver	\$ 1,000.00											0	\$ -
Lift, reachlift and boon (Gradeall)	\$ 250.00											0	\$ -
Lift, scissors	\$ 150.00											0	\$ -
Lift, fork truck	\$ 150.00											0	\$ -
Lights, work	\$ 25.00											0	\$ -
PPE	\$ 35.00	4										4	\$ 140
	\$ -											0	\$ -
Washer, pressure	\$ 75.00											0	\$ -
Scaffold, portable	\$ 88.00											0	\$ -
Tools, hand (scrapers, sledges, pry)	\$ 24.90						4	4	4			12	\$ 299
Tools, power, hand	\$ 25.00											0	\$ -
Truck, 10 wheel roll off	\$ 500.00	1	1	1	1	1	1	1	1	1		8	\$ 4,000
Truck, 6 wheel dump	\$ 344.00											0	\$ -
Truck, Equipment	\$ 150.00	2	2	2	2	2	2	2	2	2		16	\$ 2,400
Truck, Concrete Service	\$ 350.00											0	\$ -
x rental	\$ -											0	\$ -
Sub Total Equipment													\$ 14,364
Consumables	U/M												
HMA	Ton	\$ 112.80				10	10	10				30	\$ 3,384
Concrete	Yard	\$ 185.00										0	\$ -
Chemical, Sealcoat	5G	\$ 105.00										0	\$ -
Chemical, Paint	5G	\$ 120.00										0	\$ -
Container, Steel Drum, DOT	Ea	\$ 65.00										0	\$ -
Container, supersack, 1 Yd	Ea	\$ 25.00										0	\$ -
	Ea	\$ 25.00										0	\$ -
PPE, disposable (2 per MD)	Ea	\$ 34.00										0	\$ -
	Ea	\$ 89.90										0	\$ -
	Box	\$ 48.00										0	\$ -
	Box	\$ 49.90										0	\$ -
	Ea	\$ 30.00										0	\$ -
Plastic, 6 mil flame resist	Box	\$ 159.90										0	\$ -
Plastic, tape (24/box)	Ea	\$ 12.50										0	\$ -
Plastic, glue (12/Box)	Ea	\$ 6.00										0	\$ -
Tooling, diamond cup wheels 5"	Ea	\$ 325.00										0	\$ -
Tooling, diamond cup wheels 7"	Ea	\$ 407.00										0	\$ -
Tooling, ring saw blade	Ea	\$ 500.00	2									2	\$ 1,000
Tooling, cut off saw blade	Ea	\$ 210.00										0	\$ -
Tooling, concrete chain	Ea	\$ 975.00										0	\$ -
Tooling, diamond blades, small	Ea	\$ 40.00										0	\$ -
Tooling, flatsaw diamond blade	Ea	\$ 800.00										0	\$ -
Tooling, core drill	Ea	\$ 400.00										0	\$ -
Tooling, cutting blades	Ea	\$ 26.00										0	\$ -
Tooling, scraper blades	Ea	\$ 7.00										0	\$ -
Filters & Hoses	Ea	\$ 10.00										0	\$ -
x	Ea											0	\$ -
Anchors, concrete	Box	\$ 70.25										0	\$ -
x	Ea											0	\$ -
x	Ea											0	\$ -
Sub Total Consumables													\$ 4,384
Subs and Special Material													
Hotel & Per Diem	\$ 110.00											0	\$ -
Sub												0	\$ -
x	\$ -											0	\$ -
Sub Total Subs and Special Mtl													\$ -



Change Order 5

Description: Install approximately 60 LF with gate per district layout, to match new fencing installed around garden area.

Total Price:

\$7,535.46

Authorized Signature: _____

Date: _____

Bay View Play Yard Resurfacing at Bay View Elementary School - Change Order
29-20227/29/2022



Labor & Supervision

	Hours	Rate		Total	Total	Total
		Wages	Fringes			
Public Labor; ST	16	\$ 35.00	\$ 49.68	\$ 560.00	\$ 794.88	\$ 1,354.88
Public Labor; OT	0	\$ 52.50	\$ 51.98	\$ -	\$ -	\$ -
Public Labor; DT	0	\$ 70.00	\$ 53.63	\$ -	\$ -	\$ -
Public Supv; ST	16	\$ 40.00	\$ 50.68	\$ 640.00	\$ 810.88	\$ 1,450.88
Public Supv; OT	0	\$ 60.00	\$ 52.98	\$ -	\$ -	\$ -
Public Supv; DT	0	\$ 80.00	\$ 54.63	\$ -	\$ -	\$ -
Public Labor; ST		\$ 35.00	\$ 49.68	\$ -	\$ -	\$ -
Public Labor; OT	0	\$ 52.50	\$ 51.98	\$ -	\$ -	\$ -
Public Labor; DT	0	\$ 70.00	\$ 53.63	\$ -	\$ -	\$ -
Public Supv; ST		\$ 40.00	\$ 50.68	\$ -	\$ -	\$ -
Public Supv; OT	0	\$ 60.00	\$ 52.98	\$ -	\$ -	\$ -
Public Supv; DT	0	\$ 80.00	\$ 54.63	\$ -	\$ -	\$ -
Superintendent	1	\$ 110.00		\$ 110.00	\$ -	\$ 110.00
Project Manager	1	\$ 120.00		\$ 120.00	\$ -	\$ 120.00

Sub-Total 32 \$ 1,430.00 \$ 1,605.76 \$ 3,035.76

Workmans Comp 32 \$ 5.82 \$ 186.24

Mobilization & Transportation

Equipment Staging & Delivery	Hour	\$ 48.91		\$ -		
	Ea	\$ -		\$ -		
	Ea			\$ -		
	Ea	\$ -		\$ -		
Equipment Truck	Miles	\$ 1.10		\$ -		
Concrete Service Truck	Miles	\$ 1.90		\$ -		
Dump Truck (12.5 Ton)	Miles	\$ 1.90		\$ -		
Sub-Total (Mobilization & Transportation)				\$ -		\$ -

Sub-Total Equipment (see Equipment & Material Summary) \$ 350.00

Sub-Total Materials (see Equipment & Material Summary) \$ 2,980.57

Sub-Total Subs & Vendors (see Equipment & Material Summary) \$ -

Disposal

	Bins	\$ -		\$ -		
	Cu Yd	\$ -		\$ -		
Waste Transport & Disposal (Const Debris)	Cu Yard	\$ 35.00		\$ -		
Waste Transport & Disposal (Concrete/HMA)	Cu Yard	\$ 70.00		\$ -		
	Ea	\$ 90.00		\$ -		
	Ea	\$ 40.00		\$ -		
Sub-Total (Disposal)				\$ -		\$ -

Total Costs \$ 6,552.57

OH & Profit 15% \$ 982.89

Bonding 0% \$ -

Total T&M Billing \$ 7,535.46

Equipment Materials

Equipment	Day Rate	TBD	# Units	Total	\$ Extended
	\$ -			0	\$ -
	\$ -			0	\$ -
	\$ -			0	\$ -
	\$ -			0	\$ -
	\$ -			0	\$ -
	\$ -			0	\$ -
	\$ -			0	\$ -
	\$ -			0	\$ -
	\$ -			0	\$ -
Air Compressor, diesel	\$ 269.00			0	\$ -
Air Cooler	\$ 30.00			0	\$ -
Concrete, electric heavy hammer	\$ 98.00			0	\$ -
Concrete, pneumatic rivet buster	\$ 125.00			0	\$ -
Concrete, flat saw, electric	\$ 250.00			0	\$ -
Concrete, flat saw, gas	\$ 200.00			0	\$ -
Concrete, Core Drill	\$ 125.00			0	\$ -
Concrete, cut off saw	\$ 150.00			0	\$ -
Concrete, ring saw	\$ 250.00			0	\$ -
Concrete, Chain Saw	\$ 350.00			0	\$ -
Concrete, Jumping Jack	\$ 85.00			0	\$ -
Electrical, 10 GA extension cords	\$ 10.65			0	\$ -
Electrical, 6 GA distribution cords	\$ 12.00			0	\$ -
Electrical, Power Box's	\$ 45.00			0	\$ -
Electrical,45 KW generator	\$ 300.00			0	\$ -
	\$ -			0	\$ -
	\$ -			0	\$ -
Heavy Eqpt, Excavator	\$ 750.00			0	\$ -
Heavy Eqpt, Skid Steer	\$ 350.00	1		1	\$ 350
Heavy Eqpt,Skip Loader	\$ 450.00			0	\$ -
Heavy Eqpt, Paver	\$ 1,000.00			0	\$ -
Lift, reachlift and boon (Gradeall)	\$ 250.00			0	\$ -
Lift, scissors	\$ 150.00			0	\$ -
Lift, fork truck	\$ 150.00			0	\$ -
Lights, work	\$ 25.00			0	\$ -
PPE	\$ 35.00			0	\$ -
	\$ -			0	\$ -
Washer, pressure	\$ 75.00			0	\$ -
Scaffold, portable	\$ 88.00			0	\$ -
Tools, hand (scrapers, sledges, pry)	\$ 24.90			0	\$ -
Tools, power, hand	\$ 25.00			0	\$ -
Truck, 10 wheel roll off	\$ 500.00			0	\$ -
Truck, 6 wheel dump	\$ 344.00			0	\$ -
Truck, Equipment	\$ 150.00			0	\$ -
Truck, Concrete Service	\$ 350.00			0	\$ -
x rental	\$ -			0	\$ -
Sub Total Equipment					\$ 350
Consumables	U/M				
HMA	Ton	\$ 112.80		0	\$ -
Concrete	Yard	\$ 185.00		0	\$ -
Chemical, Sealcoat	5G	\$ 105.00		0	\$ -
Chemical, Paint	5G	\$ 120.00		0	\$ -
Container, Steel Drum, DOT	Ea	\$ 65.00		0	\$ -
Container, supersack, 1 Yd	Ea	\$ 25.00		0	\$ -
	Ea	\$ 25.00		0	\$ -
PPE, disposable (2 per MD)	Ea	\$ 34.00		0	\$ -
	Ea	\$ 89.90		0	\$ -
	Box	\$ 48.00		0	\$ -
	Box	\$ 49.90		0	\$ -
	Ea	\$ 30.00		0	\$ -
Plastic, 6 mil flame resist	Box	\$ 159.90		0	\$ -
Plastic, tape (24/box)	Ea	\$ 12.50		0	\$ -
Plastic, glue (12/Box)	Ea	\$ 6.00		0	\$ -
Tooling, diamond cup wheels 5"	Ea	\$ 325.00		0	\$ -
Tooling, diamond cup wheels 7"	Ea	\$ 407.00		0	\$ -
Tooling, ring saw blade	Ea	\$ 500.00		0	\$ -
Tooling, cut off saw blade	Ea	\$ 210.00		0	\$ -
Tooling, concrete chain	Ea	\$ 975.00		0	\$ -
Tooling, diamond blades, small	Ea	\$ 40.00		0	\$ -
Tooling, flatsaw diamond blade	Ea	\$ 800.00		0	\$ -
Tooling, core drill	Ea	\$ 400.00		0	\$ -
Tooling, cutting blades	Ea	\$ 26.00		0	\$ -
Tooling, scraper blades	Ea	\$ 7.00		0	\$ -
Filters & Hoses	Ea	\$ 10.00		0	\$ -
x	Ea			0	\$ -
Anchors, concrete	Box	\$ 70.25		0	\$ -
Materials	LS	\$ 2,980.57	1	1	\$ 2,981
x	Ea			0	\$ -
Sub Total Consumables					\$ 2,981
Subs and Special Material					
Hotel & Per Diem	\$ 110.00			0	\$ -
Sub				0	\$ -
x	\$ -			0	\$ -
Sub Total Subs and Special Mtl					\$ -

SANTA CRUZ CITY SCHOOL DISTRICT

AGENDA ITEM: Belli Architectural Group, Inc. Amendment Agreement: Multi-Project Overhead Architectural Services at Branciforte Middle School and Harbor High for the 22/23 Fiscal Year

MEETING DATE: August 17, 2022

FROM: Jim Monreal, Assistant Superintendent, Business Services

THROUGH: Kris Munro, Superintendent

RECOMMENDATION:

Approve the Belli Architectural Group, Inc. amendment agreement for multi-project overhead architectural services at Branciforte Middle School and Harbor High for the 22/23 fiscal year.

BACKGROUND:

The Board previously approved a master agreement with Belli Architectural Group on 12/14/16. This agreement amendment is for architectural services for the 22/23 fiscal year to include regular updates to the Santa Cruz City Schools Measure A/B Dashboard and preparation for quarterly site bond committee meetings and quarterly Board presentations in connection with the Branciforte Middle School and Harbor High School bond projects.

FISCAL IMPACT:

\$29,000.00 Estimate Measure A Funds (Restricted)

Cost Breakdown by site:

\$8,500.00 Harbor High School

\$20,500.00 Branciforte Middle School

This work is in direct support of the following District goals and their corresponding metrics:

Goal #2: SCCS will create positive, engaging school environments that promote the development of cognitive skills and the social emotional well-being of all students.

Goal #5: SCCS will maintain a balanced budget and efficient and effective management.

Goal #6: SCCS will maintain strong communication and partnership with its diverse community.

Prepared by Trevor Miller, Director, Facility Services

AGENDA ITEM: 8.3.3.

Exhibit A

**FORM OF AMENDMENT TO ADD PROJECT TO AGREEMENT
(Hourly Fee, with Not-to-Exceed Limit)**

Pursuant to the agreement between the Santa Cruz City Schools (“District”) and Belli Architectural Group, Inc.(“Architect”) effective January 17, 2017 (“Agreement”) for the Measure A construction program, the District and Architect agree to amend the Agreement to add architectural services for the following Harbor High School project (“Project”):

Multi-Project Overhead for FY 22-23

- Provide regular updates to SCCS Measure A/B Dashboard
 - Schedule items on dashboard calendar
 - Maintain a list of all project bids
 - Maintain a list of all projects under construction
 - Upload project progress photos
 - Regularly update master planning graphic materials to reflect current conditions
 - Develop and publish weekly project progress reports to Superintendent
- Provide regular updates to Architect’s Budget Tool
 - Provide updated costs as projects progress
 - Provide updated schedules as projects progress
- Prepare for, conduct and record proceedings at quarterly site bond committee meetings
- Prepare for, conduct and record proceedings at monthly principal update meetings
- Conduct quarterly presentations to the Board of Trustees relating to progress on projects

The terms of the Agreement are incorporated into, and govern, this amendment except as may be provided otherwise by this amendment. In the event of a conflict between the Agreement and this amendment, the terms of this amendment shall control.

For the Project, Architect shall perform the Basic and Additional Services specified in the Agreement and this amendment. Multiple prime construction contracts not being used as the delivery method for the Project.

For the Basic Services satisfactorily performed under this amendment to the Agreement, Architect shall be compensated according to its hourly rate schedule (*Exhibit C* to the Agreement). Architect’s total compensation for its Basic Services shall not exceed \$8,000, which is Architect’s estimate of the maximum total cost of its Basic Services on the Project.

If the total amount invoiced by Architect reaches the not-to-exceed Basic Services amount before Architect’s Basic Services under this Agreement are complete, Architect must complete the Basic

Services without submitting additional invoices, or receiving additional payment, for Basic Services.

Architect's total reimbursement for Reimbursable Expenses shall not exceed \$500 which is Architect's estimate of the maximum total cost of Reimbursable Expenses on the Project.

Architect shall provide a minimum of one (1) full-time employees for the Project to perform its duties and responsibilities under this Agreement.

For the period of this Project, the Architect shall have errors and omissions insurance on an occurrence basis, with limits of at least One Million Dollars (\$1,000,000) and with a deductible in an amount not to exceed the sum of Thirty Thousand Dollars (\$30,000).

ARCHITECT:

Belli Architectural Group, Inc.

David Peartree

By: _____
David N. Peartree, President

Digitally signed by David Peartree
DN: C=US, E=david@belliag.com,
O=Belli Architectural Group, OU=Belli
Architectural Group, CN=David
Peartree
Date: 2022.07.21 12:22:12-07'00'

DISTRICT:

SANTA CRUZ CITY SCHOOLS

By: _____
Assistant Superintendent, Business
Services

Exhibit A

**FORM OF AMENDMENT TO ADD PROJECT TO AGREEMENT
(Hourly Fee, with Not-to-Exceed Limit)**

Pursuant to the agreement between the Santa Cruz City Schools (“District”) and Belli Architectural Group, Inc.(“Architect”) effective January 17, 2017 (“Agreement”) for the Measure A construction program, the District and Architect agree to amend the Agreement to add architectural services for the following Branciforte Middle School project (“Project”):

Multi-Project Overhead for FY 22-23

- Provide regular updates to SCCS Measure A/B Dashboard
 - Schedule items on dashboard calendar
 - Maintain a list of all project bids
 - Maintain a list of all projects under construction
 - Upload project progress photos
 - Regularly update master planning graphic materials to reflect current conditions
 - Develop and publish weekly project progress reports to Superintendent
- Provide regular updates to Architect’s Budget Tool
 - Provide updated costs as projects progress
 - Provide updated schedules as projects progress
- Prepare for, conduct and record proceedings at quarterly site bond committee meetings
- Prepare for, conduct and record proceedings at monthly principal update meetings
- Conduct quarterly presentations to the Board of Trustees relating to progress on projects

The terms of the Agreement are incorporated into, and govern, this amendment except as may be provided otherwise by this amendment. In the event of a conflict between the Agreement and this amendment, the terms of this amendment shall control.

For the Project, Architect shall perform the Basic and Additional Services specified in the Agreement and this amendment. Multiple prime construction contracts not being used as the delivery method for the Project.

For the Basic Services satisfactorily performed under this amendment to the Agreement, Architect shall be compensated according to its hourly rate schedule (*Exhibit C* to the Agreement). Architect’s total compensation for its Basic Services shall not exceed \$20,000, which is Architect’s estimate of the maximum total cost of its Basic Services on the Project.

If the total amount invoiced by Architect reaches the not-to-exceed Basic Services amount before Architect’s Basic Services under this Agreement are complete, Architect must complete the Basic

Services without submitting additional invoices, or receiving additional payment, for Basic Services.

Architect's total reimbursement for Reimbursable Expenses shall not exceed \$500 which is Architect's estimate of the maximum total cost of Reimbursable Expenses on the Project.

Architect shall provide a minimum of two (1) full-time employees for the Project to perform its duties and responsibilities under this Agreement.

For the period of this Project, the Architect shall have errors and omissions insurance on an occurrence basis, with limits of at least One Million Dollars (\$1,000,000) and with a deductible in an amount not to exceed the sum of Thirty Thousand Dollars (\$30,000).

ARCHITECT:

Belli Architectural Group, Inc.

David Peartree

By: _____

David N. Peartree, President

Digitally signed by David Peartree
DN: C=US, E=david@belliag.com,
O=Belli Architectural Group,
OU=Belli Architectural Group,
CN=David Peartree
Date: 2022.07.21 12:23:28-07'00'

DISTRICT:

SANTA CRUZ CITY SCHOOLS

By: _____

Assistant Superintendent, Business
Services

SANTA CRUZ CITY SCHOOL DISTRICT

AGENDA ITEM: Bosco Construction Services, Inc. Proposal for Harbor High School Bathroom Paint

MEETING DATE: August 17, 2022

FROM: Jim Monreal, Assistant Superintendent, Business Services

THROUGH: Kris Munro, Superintendent

RECOMMENDATION:

Approve Bosco Construction Services, Inc. proposal for Harbor High School bathroom paint.

BACKGROUND:

This proposal consists of labor and materials to paint the upper and lower blockhouse restrooms. This issue arose over the summer break and required immediate action.

FISCAL IMPACT:

\$41,337.00 Measure A Funds (Restricted), representing 0.14% of the overall site budget
\$28,554,079.00 is the total Bond Allocation to Harbor High School

This work is in direct support of the following District goals and their corresponding metrics:

Goal #2: SCCS will create positive, engaging school environments that promote the development of cognitive skills and the social emotional well-being of all students.

Goal #5: SCCS will maintain a balanced budget and efficient and effective management.

Goal #6: SCCS will maintain strong communication and partnership with its diverse community.

Prepared by Trevor Miller, Director, Facility Services

Bosco

PAINTING, CONSTRUCTION AND FACILITY MAINTENANCE



ATTENTION: PAUL
PROJECT: HARBOR HIGH BATHROOM PAINTING
CUSTOMER: SANTA CRUZ UNIFIED SCHOOL DISTRICT
ESTIMATE: M1037/OPTION 2
DATE: 07-25-22
Location: 300 La Fonda Ave, Santa Cruz, Ca 95062

BOSCO CONSTRUCTION SERVICES, INC., WILL PROVIDE ALL MATERIALS AND LABOR REQUIRED AS PER THE SCOPE OF WORK FOR THE PROJECT MENTIONED ABOVE. THIS WORK WILL BE PERFORMED IN A PROFESSIONAL MANNER ACCORDING TO INDUSTRY STANDARDS.

DESCRIPTION:

Painting Locations

- Upper block House
- Lower Block House

Painting Scope.

- Paint ceiling and walls White Ash by Kelly More
 - Clear coat with a PSX 700
- Paint all the Stalls Green Thumb py Kelly More
 - Clear Coat with PSX 700
- Paint the inside of the doors Green thumb by Kelly More
 - Clear coat with PSX 700
- We will Not clear coat the PSX the Staff Bathrooms

NOT TO EXCEED REGULAR TIME PRICE: \$31,003.00

NOT TO EXCEED NIGHT SHIFT/SWING SHIFT PRICE: \$41,337.00

INCLUSIONS:

-PAINTING PREVAILING WAGES RATE FOR SANTA CRUZ.

EXCLUSIONS:

- PERMIT OR INSPECTION FEES.
- UNFORESEEN WORK/WORK NOT LISTED ABOVE IN THE DESCRIPTION.
- ENGINEERING.

RESPONSIBILITIES OF CUSTOMER:

- PROVIDE ACCESS TO ALL AREAS THAT REQUIRE INSTALLATION.
- REMIT PAYMENT UPON RECEIVING THE INVOICE.

MARCOS MORA

PROJECT MANAGER

07-25-22

7/26/22 Plus More

SANTA CRUZ CITY SCHOOL DISTRICT

AGENDA ITEM: Consolidated Plumbing Proposal for Bay View Elementary School Storm Drain Repairs

MEETING DATE: August 17, 2022

FROM: Jim Monreal, Assistant Superintendent, Business Services

THROUGH: Kris Munro, Superintendent

RECOMMENDATION:

Ratify Consolidated Plumbing proposal for Bay View Elementary School storm drain repairs.

BACKGROUND:

This proposal consists of investigation to locate blockage in the storm drain at Bay View Elementary School. The blockage was discovered, excavated, and repaired. This issue arose over the summer break and required immediate action.

FISCAL IMPACT:

\$14,063.00 Measure B Funds (Restricted), representing 0.11% of the overall site budget
\$12,384,192.00 is the total Bond Allocation to Bay View Elementary School

This work is in direct support of the following District goals and their corresponding metrics:

Goal #2: SCCS will create positive, engaging school environments that promote the development of cognitive skills and the social emotional well-being of all students.

Goal #5: SCCS will maintain a balanced budget and efficient and effective management.

Goal #6: SCCS will maintain strong communication and partnership with its diverse community.

Prepared by Trevor Miller, Director, Facility Services

AGENDA ITEM: 8.3.5.



Consolidated Plumbing, Inc. Lic. # C36-505162

Proposal & Contract

July 15, 2022

Santa Cruz City Schools
Attn: Paul Lipscomb
405 Old San Jose Rd.
Soquel, CA 95073

Jobsite:
De Laveaga Elementary School
1145 Morrissey Blvd.
Soquel, CA 95065

Consolidated Plumbing, Inc. is pleased to present the following proposal for exposing the broken storm drain line.

Scope of Work:

- Private Utility Locate.
- Saw cut and remove asphalt and excavate 6' – 8' deep to expose the pipe.
- Provide and place temporary shoring per CAL OSHA requirements.
- Cut the existing pipe and expose to remove and replace the section we have been unable to pass where we believe the pipe is broken.
- Replace as necessary up to approximately 5' of pipe and fittings.
- Video the existing downstream section to assess the line conditions we have been unable to access and view.
- Backfill and compact.
- Replace asphalt.
- Clean up and demobilization.

Exclusions:

- Work other than what is specifically noted above.
- If repairs extend beyond the excavated area noted above additional costs would apply.

General Conditions:

1. **Working Hours;** 8:00 AM. 4:30 PM. Monday through Friday.
2. **Limitations:** Santa Cruz City Schools to hold CPI harmless for damages to concrete, paving, curbs, gutters and or landscape areas for access to and from the facility during the performance of the work as specified.

Estimated Costs – (Regular Hours @ Prevailing Wage Rates)

Labor & Materials: \$14,063.00

Authorized Signature or Signatures: Owner

DATE OF ACCEPTANCE: 7/15/22

PRINT: KRIS MUNRO

SIGNATURE: Kris Munro

TITLE: Superintendent

AUTHORIZED SIGNATURE	
Project Manager Estimator	Rick Bales

TERMS OF PAYMENT AS FOLLOWS: 100% of contract due and payable within twenty days after completion of work. Any balance over thirty days past due shall bear interest at the rate of 1 1/4% per month. If any action is commenced to enforce any terms of this agreement, the prevailing party shall be entitled to reasonable attorney's fees, expert fees, and consultant fees.

NOTE: THIS PROPOSAL MAY BE WITHDRAWN BY CPI IF NOT ACCEPTED WITHIN 30 DAYS. ANY CHANGE OR DEVIATION FROM ABOVE SPECIFICATION INVOLVING EXTRA COST WILL BE ONLY WRITTEN CHANGE ORDER. ALL WORK BEYOND THE SCOPE OF THIS AGREEMENT WILL BE PAID BY THE OWNER PURSUANT TO THE TERMS OF THE CHANGE ORDER. EXECUTION OF THIS AGREEMENT BY OWNER CONFIRMS THAT THE ABOVE PRICES, SPECIFICATIONS AND CONDITIONS ARE SATISFACTORY AND ARE HEREBY ACCEPTED AND THAT CPI IS AUTHORIZED TO DO THE WORK AS SPECIFIED. PAYMENT WILL BE MADE AS OUTLINED ABOVE.

NOTE: For the purposes of this estimate it is assumed that the repairs will be limited to the exposed area. If it is found that additional work is warranted, including, without limitation, any subsurface or latent issues, we will stop and inform you of the findings and determine if more work is to be considered. Additional costs will apply for any work not specifically noted within this proposal.

The form and content of this proposal is the copyright of Consolidated Plumbing Inc., and cannot be reproduced or distributed in whole or in part without the written permission of Consolidated Plumbing Inc.

SANTA CRUZ CITY SCHOOL DISTRICT

AGENDA ITEM: Creative Window Interiors Proposal for DeLaveaga Elementary School Window Shades

MEETING DATE: August 17, 2022

FROM: Jim Monreal, Assistant Superintendent, Business Services

THROUGH: Kris Munro, Superintendent

RECOMMENDATION:

Ratify Creative Window Interiors proposal for DeLaveaga Elementary School window shades.

BACKGROUND:

This proposal consists of labor and materials to install three Dual Mecho manual roller shades at the perimeter windows of DeLaveaga Elementary School as part of the District modernization standards. This issue arose over the summer break and required immediate action.

FISCAL IMPACT:

\$4,140.00 Measure B Funds (Restricted), representing 0.02% of the overall site budget
\$14,188,861.00 is the total Bond Allocation to DeLaveaga Elementary School

This work is in direct support of the following District goals and their corresponding metrics:

Goal #2: SCCS will create positive, engaging school environments that promote the development of cognitive skills and the social emotional well-being of all students.

Goal #5: SCCS will maintain a balanced budget and efficient and effective management.

Goal #6: SCCS will maintain strong communication and partnership with its diverse community.

Prepared by Trevor Miller, Director, Facility Services



**CREATIVE WINDOW
INTERIORS, INC.**

commercial blinds & drapery

June 20, 2022

Christopher Garcia 831.429.3904 ext. 59108 cgarcia@sccs.net
Santa Cruz City Schools
133 Mission St Suite 100
Santa Cruz, CA 95060

Re: Perimeter Dual Manual Roller Shades
Delaveaga Elementary School
1145 Morissey Blvd
Santa Cruz, CA 95065

Chris,

We will provide and install (3) Dual Mecho manual roller shades at the perimeter windows (see attached rendering for location). Your pricing is based upon using Mecho Chelsea 0250 Series 0% openness fabric (color 0273 Graphite) for the room darkening fabric and Mecho ThermoVeil 2100 Series 10% openness fabric (color 2119 Silver Birch). The shades will be surface mounted to the window mullions. The shade will have a fascia (color Clear Anodized) to help conceal the rolled-up fabric and mechanism. Your price includes all necessary tax, materials, and labor to be done during normal business hours.

Total Installed Price \$4,140.00

Notes:

- *Pricing is good for 90 days.
- *See attached fabric/color sheets & rendering for shade locations.
- *Lead time for Mecho is 4-5 weeks after approval.

Sincerely,
Jason Lyman 503.984.4308
jason@creativewindowinteriors.com
Creative Window Interiors, Inc.

X  06/22/22
Approved by _____ date



**CREATIVE WINDOW
INTERIORS, INC.**
commercial blinds & drapery

= Manual Dual Mecho Roller Shades



Chelsea Blackout

0250 Series (opaque)

This PVC-free fabric combines a fine fabric with solid, graphite or white-colored backing to create a shade cloth that is opaque and attractive from interior and exterior viewpoints.

Visit mechoshade.com to request samples.

Fire Classification | NFPA 701-2015

Shade Cloth Properties | other side

Railroading Available | Yes

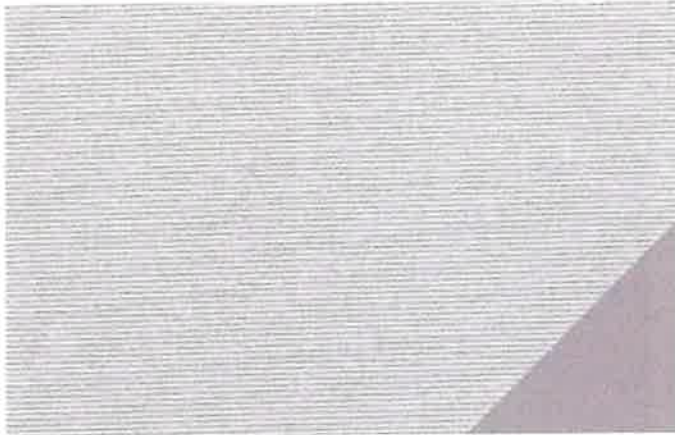

0254 Shale | *Graphite Back

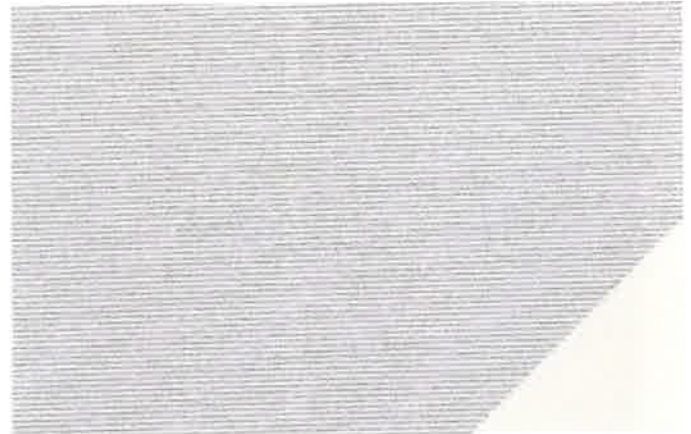

0274 Shale | *White Back



Chalk
*0251 | *0271



Pearl
*0265 | *0285



Sand
*0252 | *0272

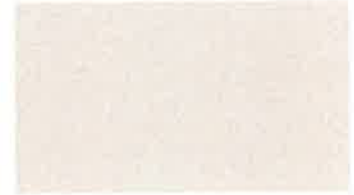

Napa
*0258 | *0278



Silver
*0260 | *0280

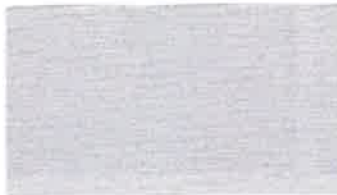

Shale
*0254 | *0274



Slate
*0262 | *0282



Graphite
*0253 | *0273



Steel
*0264 | *0284



Onyx
*0263 | *0283



Selected Color



(718) 729-2020
mechoshade.com

ThermoVeil®

1700 Series (1% open), 1500 Series (3% open), 1300 Series (5% open) **2100 Series (10% open)**

This series is composed of a technically advanced material woven in a 2 x 2 basket-weave pattern. Its weave provides a uniform scrim effect at the window wall with an appropriate density for sun control.

Visit mechoshade.com for most up-to-date fabric information and to request samples.

Fire Classification | NFPA 701

Bacteria & Fungal Resistance | ASTM G21 & ASTM E2180

Railroading Available | Yes

Shade Cloth Properties | other side

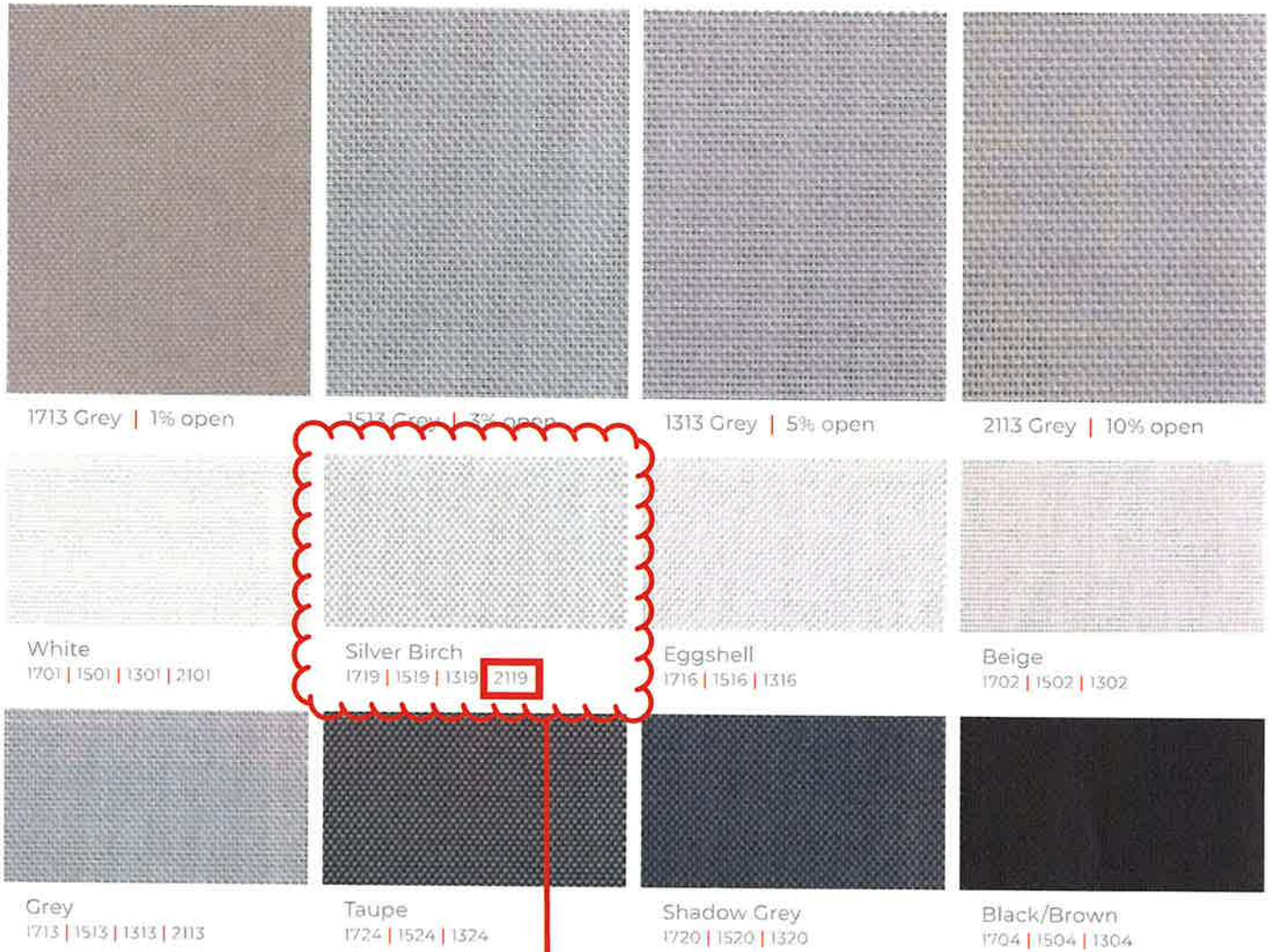

Selected Color



(718) 729-2020
mechoshade.com

Mecho® DoubleShade®

DoubleShades have all the same features of the standard Mecho/5 or 5x brackets, plus support light-filtering and room-darkening shadecloth on the same bracket – a compact, efficient solution for mixed-use spaces.

Compact Size

DoubleShade's compact size allows two shades to fit in a smaller room projection than two individually installed shades on the same window.

Ease of Installation

DoubleShades provide faster, easier, more economical installation of two shades per window. The mounting brackets require less measuring and are pre-spaced to insure proper alignment of both shades in relation to each other.

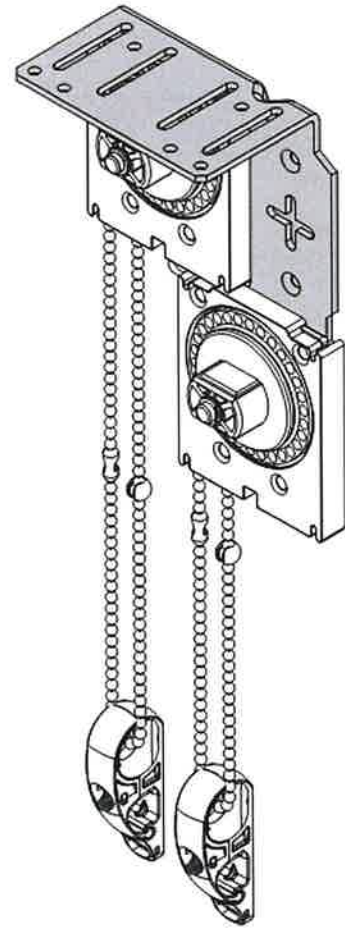

DoubleShade #15

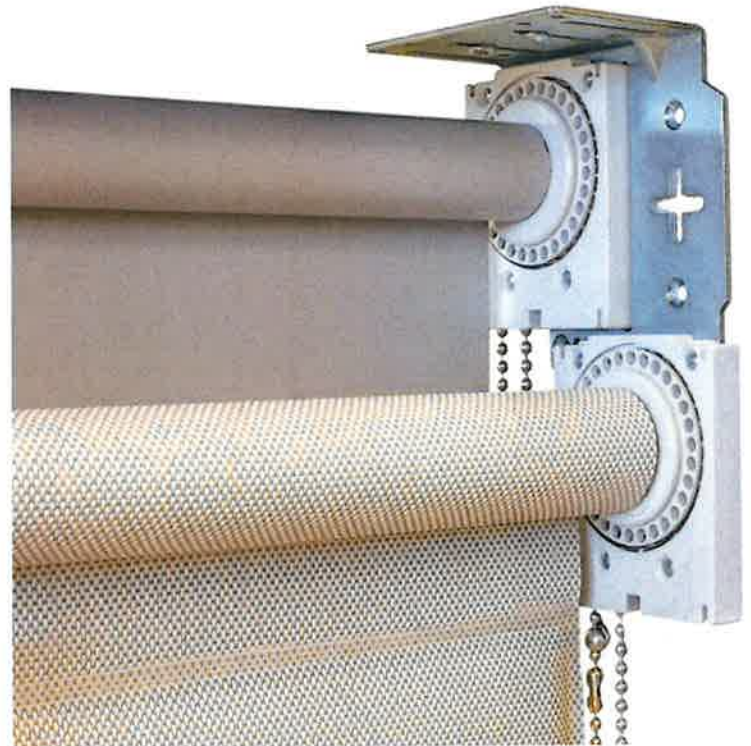
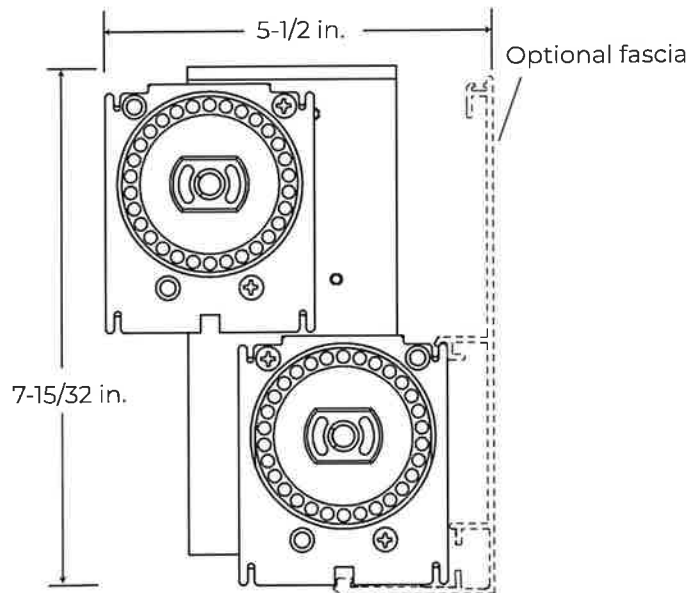

(718) 729-2020
mechoshade.com

Fascia



Fascia

Colors: BK, AL, WH, CA, QB, CW, GR

**Electro/2
Extended**
BK, CA, GR,
QB, WH

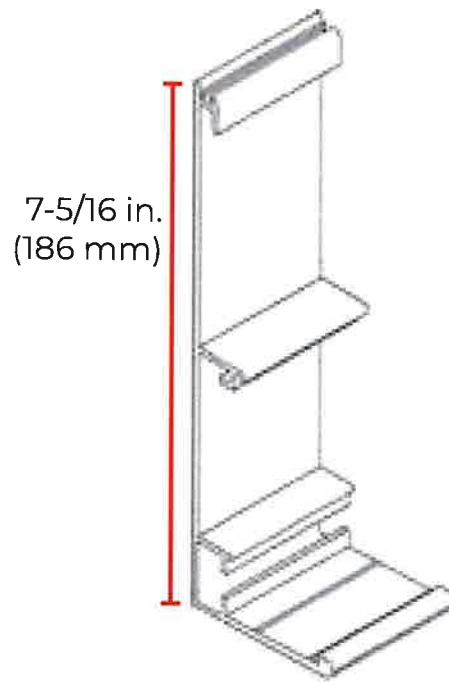

Color options



BK = Black

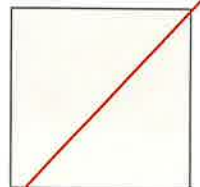

~~AL = Alabaster~~

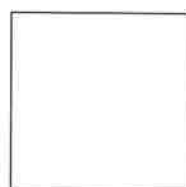

WH = White



CA = Clear Anodized



QB = Quaker Bronze

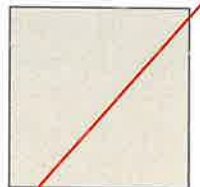

~~CW = Colonial White~~



GR = Grey

Selected Color

Regular Roll with Fascia, Wall Mount

Mecho Construction Details

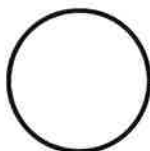
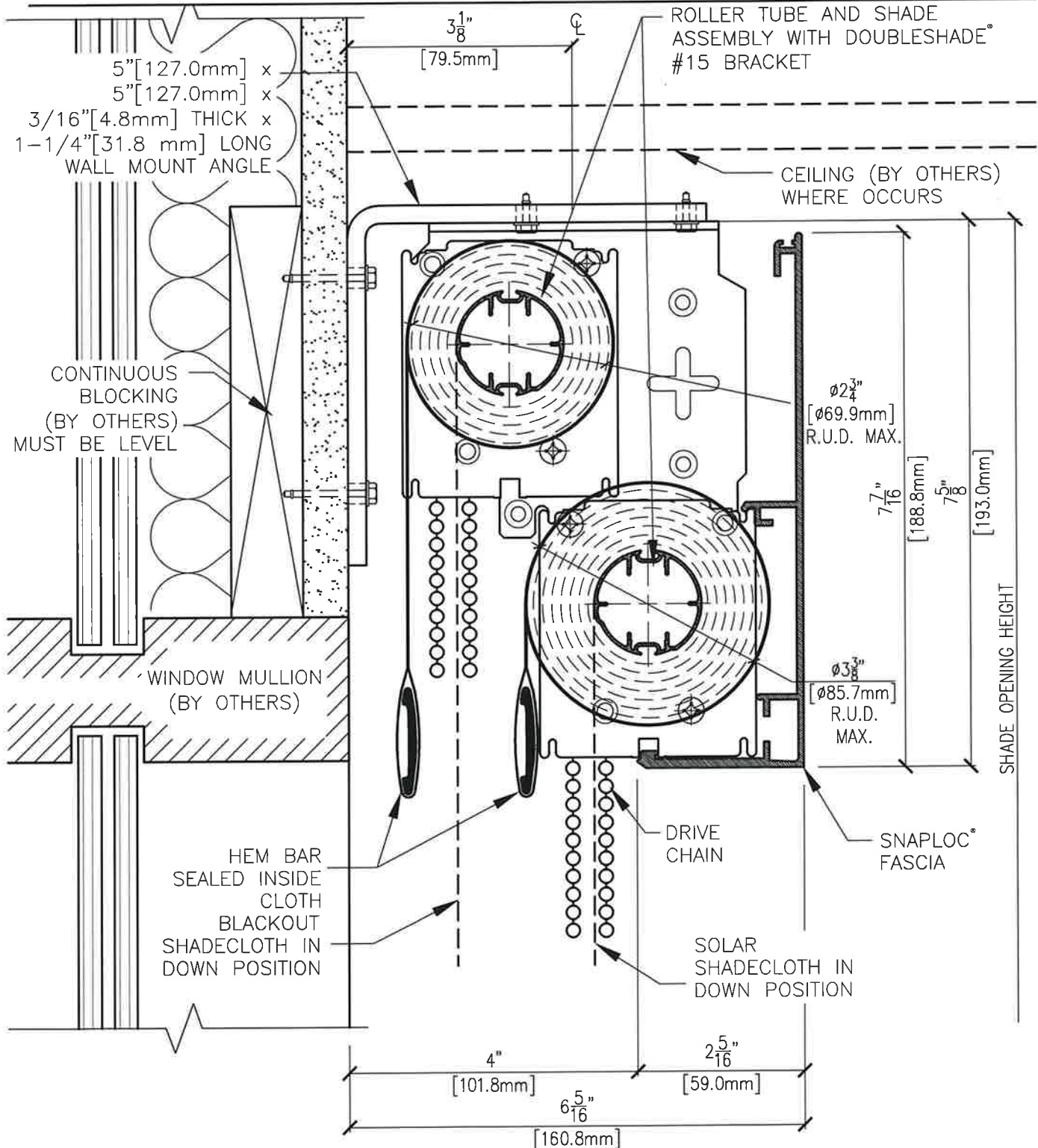

SECTION AT WINDOW HEAD

SCALE: 1/2 FULL SIZE

SANTA CRUZ CITY SCHOOL DISTRICT

AGENDA ITEM: CRW Industries Change Order #6 for Santa Cruz High School Switchgear Replacement

MEETING DATE: August 17, 2022

FROM: Jim Monreal, Assistant Superintendent, Business Services

THROUGH: Kris Munro, Superintendent

RECOMMENDATION:

Approve CRW Industries change order #6 for Santa Cruz High School switchgear replacement.

BACKGROUND:

This change order consists of independent operation verification of new electrical service. An independent operation verification is done by an outside entity to verify the design engineer's plans will meet our site needs. We asked for this additional service after the initial bid to ensure we had an objective outside assessment. The previously approved contract amount was \$1,475,722.29 and the new total contract, including this change order, will be \$1,497,399.33.

FISCAL IMPACT:

Change Order #6 \$21,677.04 (1.46% increase to the contract), Measure A Funds (Restricted)

This work is in direct support of the following District goals and their corresponding metrics:

Goal #2: SCCS will create positive, engaging school environments that promote the development of cognitive skills and the social emotional well-being of all students.

Goal #5: SCCS will maintain a balanced budget and efficient and effective management.

Goal #6: SCCS will maintain strong communication and partnership with its diverse community.

Prepared by Trevor Miller, Director, Facility Services



AIA® Document G701™ – 2017

Change Order

PROJECT: <i>(name and address)</i> SCHS Switchgear Replacement 415 Walnut Ave, Santa Cruz	CONTRACT INFORMATION: Contract For: Final Commissioning Date: 06/01/2022	CHANGE ORDER INFORMATION: Change Order Number: 006 Date: 06/14/2022
OWNER: <i>(name and address)</i> Santa Cruz City School 133 Mission Street Suite 100 Santa Cruz, CA 95069	ARCHITECT: <i>(name and address)</i> Mark E. Bartos 300 8th ave Suite 202 San Mateo, CA 94401	CONTRACTOR: <i>(name and address)</i> CRW Industries, Inc. 5346 Scotts Valley Dr. STE E Scotts Valley, CA 95066

THE CONTRACT IS CHANGED AS FOLLOWS:

(Insert a detailed description of the change and, if applicable, attach or reference specific exhibits. Also include agreed upon adjustments attributable to executed Construction Change Directives.)

ADD \$21,677.04 - Final Commissioning (per RFI 7)

The original (Contract Sum) was	\$	<u>1391313.00</u>
The net change by previously authorized Change Orders	\$	<u>84409.29</u>
The (Contract Sum) prior to this Change Order was	\$	<u>1475722.29</u>
The (Contract Sum) will be (increased) by this Change Order in the amount of	\$	<u>21677.04</u>
The new (Contract Sum), including this Change Order, will be	\$	<u>1497399.33</u>
The Contract Time will be (increased) by Zero (0) days.		
The new date of Substantial Completion will be 05 May, 2022		

NOTE: This Change Order does not include adjustments to the Contract Sum or Guaranteed Maximum Price, or the Contract Time, that have been authorized by Construction Change Directive until the cost and time have been agreed upon by both the Owner and Contractor, in which case a Change Order is executed to supersede the Construction Change Directive.

NOT VALID UNTIL SIGNED BY THE ARCHITECT, CONTRACTOR AND OWNER.

Bartos Architecture <small>DocuSigned by: ARCHITECT (Firm name)</small> <u>Mark Bartos</u> <small>25F01B10B9524A1...</small> SIGNATURE	CRW Industries, Inc. <small>DocuSigned by: CONTRACTOR (Firm name)</small> <u>Bill Burr</u> <small>0FCAB0AFCD664FB...</small> SIGNATURE	Santa Cruz City Schools <small>DocuSigned by: OWNER (Firm name)</small> SIGNATURE
Mark Bartos, Principal PRINTED NAME AND TITLE	Bill Burr, President PRINTED NAME AND TITLE	 PRINTED NAME AND TITLE
7/20/2022 DATE	7/27/2022 DATE	 DATE

AIA Document G701™ – 2017. Copyright © 1979, 1987, 2000, 2001 and 2017 by The American Institute of Architects. All rights reserved. **WARNING:** This AIA® Document is protected by U.S. Copyright Law and International Treaties. Unauthorized reproduction or distribution of this AIA® Document, or any portion of it, may result in severe civil and criminal penalties, and will be prosecuted to the maximum extent possible under the law. This document was created on 06/14/2022 20:02:12 under the terms of AIA Documents-on-Demand™ Order No. 2114334048, and is not for resale. This document is licensed by The American Institute of Architects for one-time use only, and may not be reproduced prior to its completion.

Santa Cruz High School Switchgear Replacement

Job Number: 5303

DATE: 6/1/2022

CONTRACTOR: **CRW Industries Inc**

PCO #: 10

PCO - COST PROPOSAL - PRIME CONTRACTOR

DESCRIPTION OF CHANGE: Final Commissioning per RFI 7.

ITEM DESCRIPTION	MATERIAL (sales tax included)				LABOR (fully encumbered)			EQUIPMENT (attach invoice)		
	QUANTITY	UNIT	UNIT COST	EXTENSION	QUANTITY HOURS	RATE	EXTENSION	QUANTITY	UNIT COST	EXTENSION
							\$ -			
SUBTOTALS:				\$ -			\$ -			\$ -

MATERIAL	\$0.00
LABOR	\$0.00
EQUIPMENT	\$0.00
SUBTOTAL DIRECT COSTS	\$0.00
FEE ON DIRECT COSTS (15%)	\$0.00
PRIME CONTRACTOR SUBTOTAL	\$0.00

Sub Contractor Costs from Attached Cost Proposal(s)

PSR Electric	\$20,240.00
5% FEE ON SUBCONTRACTOR DIRECT COSTS	\$1,012.00
SUBCONTRACTOR SUBTOTAL	\$21,252.00
PCO SUBTOTAL	\$ 21,252.00
BOND (not to exceed 2% of sub total)	\$ 425.04
TOTAL	\$ 21,677.04

PREPARED & SUBMITTED BY: Bill Burr
 COMPANY: CRW TITLE: Pres



PROPOSAL LETTER

To PSR Electric
Tel: (831) 345-3914
Fax:
Att Pedro Sauce

Proposal number Rev
HP 17583

Proposal date
3/7/2022

Bid date
3/7/2022

Description Acceptance Testing
Name Santa Cruz Highschool
Location 133 Mission Street, Suite 100

Santa Cruz CA

Scope of work

Provide technical services and equipment to perform testing as per NETA on the following equipment:

Drawing E2.2

1. (New) 4000A, Switchboard MSB-1 (IEM Switchboard, Siemens Breakers)

SWBD Test & Inspection

One (1) 4000A Main Circuit Breaker

One (1) 1600A Circuit Breaker

Three (3) 800A Circuit Breakers

One (1) 600A Circuit Breaker

Three (3) 400A Circuit Breakers

Five (5) Circuit Breakers [200A - 300A]

2. One (1) (New) 500KVA, Low-Voltage, Dry-Type Transformer [480/277v - 120/208v]

3. (New) PV Distribution Panel

Panel Test & Inspection

One (1) 800A Circuit Breaker

4. (New) Distribution Panel A (MSB-2)

Panel Test & Inspection

One (1) 1600A Main Circuit Breaker

Four (4) 600A Circuit Breakers

Four (4) 400A Circuit Breakers

Thirteen (13) Circuit Breakers [100A - 300A]

6736 Preston Avenue, Suite E, Livermore, CA 94551 Ph. (510) 783 5096 Fax (510) 785-6480

Monday, March 7, 2022

2:13:59 PM

Page 1 of 4

5. Ground System Test (New Equipment Listed Above)

6. PST-Supplied Generator

7. Short Circuit, Coordination & Arc Flash Studies

EXCLUSIONS:

26 05 10 General Electrical Requirements

3.03 Field Tests - B - "Properly calibrate, adjust and operationally check all circuits and components, and demonstrate as ready for service." - N/A, by others

3.03 - C - N/A, PST calibrates digital test equipment every 12 months, per NETA's standards

3.03 - D. Operational Tests - N/A, all operational tests by others. Tests of LV cable, branch circuits, control wiring, etc, will be by others

3.03 - E - (Re-tests will require change order if they are needed)

3.04 Cleaning Equipment - (cleaning by others)

3.07 Clean Up - (cleaning by others)

26 05 12 Shutdowns, Switching, Phasing & Cutovers

1.04 Shutdowns - B - Shutdowns can take place during normal, weekday hrs per customer

26 05 19 Low Voltage Wire and Cable

N/A, all cable tests by others

Section 26 05 73 - Over-Current Protective Device Coordination and Arc Flash Study

260573 1.04 B – N/A, we are not a switchgear manufacturer. We are a 3rd party test & engineering firm.

260573 2.01 – we will use SKM

260573 3.02 A – customer to gather and provide all data

260573 3.03 - B - N/A, PST's tests can only be performed on de-energized equipment.

260573 3.04 – N/A, customer to apply arc flash labels

Section 26 24 16 - Panelboards and Distribution Panels

3.03 Field Tests - A - N/A, all LV cable will be by others

3.03 - C. Continuity - N/A, by others

Section 26 25 13 - Low Voltage Busways

N/A, no busway in project scope

6736 Preston Avenue, Suite E, Livermore, CA 94551 Ph. (510) 783 5096 Fax (510) 785-6480

Monday, March 7, 2022

2:14:00 PM

Page 2 of 4

409/713

Section 26 24 13 - Switchboards, 600 Volts And Below
3.04 Field Tests - A - N/A, all LV cable will be by others
3.04 - C. Continuity - N/A, by others

TERMS AND CONDITIONS

Testing shall be performed during straight time hours only.

Tests are performed per NETA ATS (optional NETA tests are not offered or included).

Circuit Breakers rated less than 100Amp are not included in PST's test scope.

A pdf copy of test report will be provided with test procedures, test data sheets and any applicable discrepancies found & recommendations. Hard copies of report available upon request.

Price is based on performing scope of work in contiguous work days and hours. Any work that is scheduled by contractor before all equipment is installed, will incur additional mobilization charges.

Services, components, or equipment not listed above are not included in this proposal.

Any site safety training needed will be billed on a T&M basis and is not included in this proposal.

Any and all specifications associated with above project and not listed here may be deemed as an exception unless agreed by both parties in writing to be part of the scope of this proposal.

Any unplanned standby time due to customer operating conditions or utility delays will be billed on a T&M basis.

Insurance requirements that deviate from our standard limits or requirements may incur a fee.

Purchase orders or contracts must refer to proposal for scope of work.

Any retests will require change order.

All test equipment to be used shall be calibrated every 12 months.

POWER SYSTEMS TESTING CO. DOES NOT SIGN INTO PROJECT LABOR AGREEMENTS

Client responsibilities

ACCEPTANCE TESTING

1. Provide test power within 50 ft of equipment to be tested. Power requirements will be determined once a contract has been executed.
2. Provide a minimum of 4-5 week notice for testing schedule for each mobilization.
3. Provide free and clear access as defined by NFPA 70 E article 100 to equipment to be tested.
4. Provide one qualified person to identify equipment.
5. Perform all switching and isolating of equipment to be tested.
6. Clean, tighten, and torque all connections.
7. Provisions for transportation of test equipment above or below the 1st floor.
8. Provide shutdown to equipment.
9. Protective device settings must be provided prior to test dates. Return trips to change or

6736 Preston Avenue, Suite E, Livermore, CA 94551 Ph. (510) 783 5096 Fax (510) 785-6480

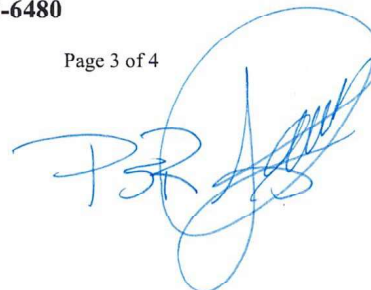

reset will be an additional charge.

10. Provide a purchase order or contract for the work listed prior to scheduling.
11. Provide exemption to any project labor agreements.

Coordination/Arc Flash Study

1. Provide all information necessary to complete the Short Circuit Coordination & Arc Flash Studies.
2. Install labels generated by study.
3. Allow 3-4 weeks ARO and Receipt of all data by Engineer for completion of study.

PRICING:

Acceptance Testing - \$16,190.00

Generator Rental - \$750.00

Power System Studies - \$3,300.00

TOTAL: \$20,240.00

- ON A TIME A MATERIALS BASIS, FOR A COST NOT TO EXCEED: \$0.00
- FOR A FIRM PRICE OF: \$20,240.00 *Please schedule*
- THIS PROPOSAL IS VALID FOR: 90 DAYS

Note: Unless otherwise stated, all costs are based on straight time rates.

SIGNED: _____

Jacob Alford
POWER SYSTEMS TESTING COMPANY

6736 Preston Avenue, Suite E, Livermore, CA 94551 Ph. (510) 783 5096 Fax (510) 785-6480

Monday, March 7, 2022

2:14:00 PM

Page 4 of 4

411/713

SANTA CRUZ CITY SCHOOL DISTRICT

AGENDA ITEM: CRW Industries Inc. Proposal for Harbor High School Food Service Office Disposal

MEETING DATE: August 17, 2022

FROM: Jim Monreal, Assistant Superintendent, Business Services

THROUGH: Kris Munro, Superintendent

RECOMMENDATION:

Ratify CRW Industries Inc. proposal for Harbor High School food service office removal.

BACKGROUND:

This proposal consists of the disposal of the food service office portable building at Harbor High School due to its poor condition. This issue arose over the summer break and required immediate action.

FISCAL IMPACT:

\$19,000.00 Total

Cost Breakdown by fund:

\$12,350.00 Measure A District Set-Aside (Restricted)

\$6,650.00 Elementary Redevelopment Agency Fund (Restricted)

This work is in direct support of the following District goals and their corresponding metrics:

Goal #2: SCCS will create positive, engaging school environments that promote the development of cognitive skills and the social emotional well-being of all students.

Goal #5: SCCS will maintain a balanced budget and efficient and effective management.

Goal #6: SCCS will maintain strong communication and partnership with its diverse community.

Prepared by Trevor Miller, Director, Facility Services

AGENDA ITEM: 8.3.8.

CRW Industries, Inc.

5346 Scotts Valley Drive, STE E
 Scotts Valley, CA 95066
 831.426.0743 ofc - 831.466.9597 fax

Proposal

Customer

Name Trevor Miller- Santa Cruz City Schools
 Address 536 Palm St
 City Santa Cruz State CA ZIP 95060
 Phone 831-239-2586

Date 07/12/2022
 Order No. _____
 Rep Bill Burr
408-426-0806

Qty	Description	Unit Price	TOTAL
	Harbor High School Food Service Portable Removal Safe off Electrical Demolition of Low Voltage Metal Deck/Ramp and Portable Removal	\$19,000.00	

Authorization

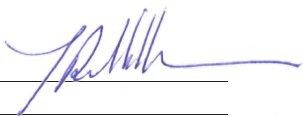
Name Trevor Miller 

SubTotal	\$19,000.00
Shipping & Handling	
Taxes	
State	
TOTAL	\$19,000.00

Office Use Only

Thank you for choosing CRW Industries, Inc.

SANTA CRUZ CITY SCHOOL DISTRICT

AGENDA ITEM: Development Group, Inc. Proposal for Soquel High School Vape Detectors

MEETING DATE: August 17, 2022

FROM: Jim Monreal, Assistant Superintendent, Business Services

THROUGH: Kris Munro, Superintendent

RECOMMENDATION:

Ratify Development Group, Inc. proposal for Soquel High School vape detectors.

BACKGROUND:

This proposal consists of the purchase of vape detectors in the 300 building student restrooms of Soquel High School. These devices detect loud noises from vandalism, as well as CO2. These were installed as part of a trial and staff determined that they were beneficial and this contract represents their final purchase. This issue arose over the summer break as the contract was ending and required immediate action.

FISCAL IMPACT:

\$3,842.10 Measure A Funds (Restricted), representing 0.01% of the overall site budget
\$34,830,967.00 is the total Bond Allocation to Soquel High School

This work is in direct support of the following District goals and their corresponding metrics:

Goal #2: SCCS will create positive, engaging school environments that promote the development of cognitive skills and the social emotional well-being of all students.

Goal #5: SCCS will maintain a balanced budget and efficient and effective management.

Goal #6: SCCS will maintain strong communication and partnership with its diverse community.

Prepared by Trevor Miller, Director, Facility Services

AGENDA ITEM: 8.3.9.

Company:
SANTA CRUZ CITY SCHOOLS

Proposal #27841

Requested By:
Trevor Miller
 Director, Facility Services



Description:
Verkada Trial Sensors Purchase (DO NOT SHIP)

Bill To: SANTA CRUZ CITY SCHOOLS 133 Mission St Santa Cruz, CA 95060-3754	Ship To: SANTA CRUZ CITY SCHOOLS 133 Mission St Santa Cruz, CA 95060-3754	Sold To: SANTA CRUZ CITY SCHOOLS 133 Mission St Santa Cruz, CA 95060-3754
Created: 7/8/2022 Expires: 8/8/2022 Version: 1	Account Manager: nslocum Systems Engineer: romalley	Payment Terms: Net 30

Product & Manufacturer Maintenance

Line No	Qty	Product	SMARTnet	Unit Price	Ext'd Price	Tax
1	2	SV11-HW SV11 Environmental Sensor		959.20	1,918.40	T
2	2	LIC-SV-5Y 5-Year SV11 License		799.20	1,598.40	T
<p style="text-align: center;">Need more time to get important stuff done? Ask us about</p> 				Subtotal Handling Estimated Sales Tax (9.25%) SMARTnet Professional Services Shipping Total	\$3,516.80 \$0.00 \$325.30 \$0.00 \$0.00 \$0.00 \$3,842.10	

Trevor Miller

SANTA CRUZ CITY SCHOOL DISTRICT

AGENDA ITEM: Dilbeck & Sons Proposal for Touch Panel Installation

MEETING DATE: August 17, 2022

FROM: Jim Monreal, Assistant Superintendent, Business Services

THROUGH: Kris Munro, Superintendent

RECOMMENDATION:

Ratify Dilbeck & Sons proposal for touch panel installation at Santa Cruz High School, Soquel High School, and Branciforte Small Schools.

BACKGROUND:

This proposal consists of labor and materials to install interactive touch panels in classrooms at Santa Cruz High School, Soquel High School, and Branciforte Small Schools as part of the District modernization standards. This issue arose over the summer break and required immediate action.

FISCAL IMPACT:

\$85,112.00 Total

Cost Breakdown by Site:

\$51,690.00.00 Measure A Funds (Restricted), Soquel High School

\$4,247.00 Measure A Funds (Restricted), Santa Cruz High School

\$29,175.00 Measure B Funds (Restricted), Branciforte Small Schools

This work is in direct support of the following District goals and their corresponding metrics:

Goal #2: SCCS will create positive, engaging school environments that promote the development of cognitive skills and the social emotional well-being of all students.

Goal #5: SCCS will maintain a balanced budget and efficient and effective management.

Goal #6: SCCS will maintain strong communication and partnership with its diverse community.

Prepared by Trevor Miller, Director, Facility Services



P.O. Box 6088
26 Quail Run Circle

License No. 430708
Salinas, CA 93912

Telephone (831) 422-8213
Fax (831) 422-1882

PROPOSAL SUBMITTED TO SANTA CRUZ CITY SCHOOL		PHONE 831-429-3883	DATE 7/22/2022
STREET 133 MISSION ST SUITE 100		JOB NAME INSTALL 30 NEW TV'S	
CITY, STATE AND ZIP CODE SANTA CRUZ, CA 95060		JOB LOCATION SOQUEL HIGH SCHOOL	
ARCHITECT N/A	DATE OF PLANS	ATTN: CHRIS	JOB PHONE

We hereby submit specifications and estimates for:

1. RELOCATE EXISTING MARKER BOARDS AS REQUIRED.
2. INSTALL NEW WOOD MOUNTING BOARD FOR EACH T.V.
3. MOUNT OWNER PROVIDED T.V.'S
4. INSTALL NEW SURFACE MOUNTED ELECTRICAL OUTLET FROM EXISTING WALL ELECTRICAL GUTTER

PRICE INCLUDES TWO SATURDAYS WORK

EXCLUDES: PAINTING, OPEN OR PATCH BACK WALLS, NEW ELECTRICAL CIRCUITS, FLOORING, NEW MARKER BOARDS, BACKING FOR RELOCATED MARKER BOARDS

"Contractors are required by law to be licensed and regulated by the Contractors' State License Board. Any questions concerning a contractor may be referred to the Registrar, Contractors' State License Board, P.O. Box 26000, Sacramento, CA 95826"

We propose hereby to furnish material and labor - complete in accordance with the above specifications, for the sum of:

FIFTY-ONE THOUSAND SIX HUNDRED NINETY

DOLLARS (\$51,690)

Payment to be made as follows:

All material is guaranteed to be as specified. All work to be completed in a workmanlike manner according to standard practices. Any alteration or deviation from above specifications involving extra costs will be executed only upon written orders and will become an extra charge over and above the estimate. All agreements contingent upon strikes, accidents or delays beyond our control. Owner to carry fire, tornado and other

Authorized

Signature Carrie McCoun

Note: This proposal may be withdrawn by us if not accepted within _____ days

ACCEPTANCE OF PROPOSAL - The above prices, specifications and conditions are satisfactory and are hereby accepted. You are authorized to do the work as specified. Payment will be made as outlined above.

Signature _____

Signature _____

Date of Acceptance:

7/26/22



P.O. Box 6088
26 Quail Run Circle

License No. 430708
Salinas, CA 93912

Telephone (831) 422-8213
Fax (831) 422-1882

PROPOSAL SUBMITTED TO SANTA CRUZ CITY SCHOOLS		PHONE 831-429-3883	DATE 7/8/2022
STREET 133 MISSION ST., SUITE 100		JOB NAME T.V INSTALLATION	
CITY, STATE AND ZIP CODE SANTA CRUZ, CA 95060		JOB LOCATION SANTA CRUZ HIGH SCHOOL	
ARCHITECT N/A		ATTN: TREVOR	JOB PHONE

We hereby submit specifications and estimates for:

1. CUT AND SAND 1 1/4" PLYWOOD BACKING
2. PICK UP T.V.'S AT DIFFERENT SITE AND DELIVER TO JOB SITE.
3. INSTALL PLYWOOD BACKING
4. INSTALL OWNER PROVIDED T.V.'S
5. CLEAN UP AND HAUL OFF CARDBOARD AND UNUSED MATERIAL SITE

ADD 1.5% IF BOND NEEDED

EXCLUDES: T.V.'S, ELECTRICAL, DATA, RELOCATING OF MARKER BOARDS

"Contractors are required by law to be licensed and regulated by the Contractors' State License Board. Any questions concerning a contractor may be referred to the Registrar, Contractors' State License Board, P.O. Box 26000, Sacramento, CA 95826"

We propose hereby to furnish material and labor - complete in accordance with the above specifications, for the sum of:

FOUR THOUSAND TWO HUNDRED FORTY-SEVEN DOLLARS (\$4,247)

BASE BID ONLY

All material is guaranteed to be as specified. All work to be completed in a workmanlike manner according to standard practices. Any alteration or deviation from above specifications involving extra costs will be executed only upon written orders and will become an extra charge over and above the estimate. All agreements contingent upon strikes, accidents or delays beyond our control. Owner to carry fire, tornado and other necessary insurance. Our works are fully covered by Workmen's Compensation Insurance.

Authorized

Signature: *Carrie McCoun*

Note: This proposal may be withdrawn by us if not accepted within _____ days

ACCEPTANCE OF PROPOSAL - The above prices, specifications and conditions are satisfactory and are hereby accepted. You are authorized to do the work as specified. Payment will be made as outlined above.

Signature _____

Signature _____

Date of Acceptance: _____



**P.O. Box 6088
26 Quail Run Circle**

**License No. 430708
Salinas, CA 93912**

**Telephone (831) 422-8213
Fax (831) 422-1882**

PROPOSAL SUBMITTED TO SANTA CRUZ CITY SCHOOL		PHONE 831-429-3883	DATE 6/17/2022
STREET 133 MISSION ST SUITE 100		JOB NAME MOUNT TV'S	
CITY, STATE AND ZIP CODE SANTA CRUZ, CA 95060		JOB LOCATION BRANCIFORTE SCHOOL	
ARCHITECT N/A	DATE OF PLANS	ATTN: CHRIS	JOB PHONE

We hereby submit specifications and estimates for:

- 1. PROVIDE BACKING FOR 15 T.V. STATIONS INCLUDING MOUNTING. ALL T.V.'S MOUNTED TO 1 1/8 PLYWOOD BACKING, PRIME BACK SIDE OF PLYWOOD WHERE IN CONTACT WITH BLOCK WALLS.**
- 2. TRIM OUT BACK SIDE OF T.V.'S IN (3) THREE CLASSROOMS**
- 3. CUT OUT TACK BOARD IN (14) FOURTEEN ROOMS AS REQUIRED FOR PLYWOOD BACKING**
- 4. PROVIDE ELECTRICAL FOR T.V.'S IN (5) FIVE CLASSROOMS**
- 5. RELOCATE T.V.'S FROM SOQUEL TO BRANCIFORTE**
- 6. CLEAN UP AND REMOVE ALL UNUSED MATERIAL FROM SITE**
- 7. RELOCATE EXISTING CHALKBOARDS IN (2) TWO ROOMS**

EXCLUDES: LEAD OR ASBESTOS REMOVAL, PAINTING, HVAC, PLUMBING, FLOORING, BASE, CEILING TILE

"Contractors are required by law to be licensed and regulated by the Contractors' State License Board. Any questions concerning a contractor may be referred to the Registrar, Contractors' State License Board, P.O. Box 26000, Sacramento, CA 95826"

We propose hereby to furnish material and labor - complete in accordance with the above specifications, for the sum of:
TWENTY-NINE THOSAND ONE HUNDRED SEVENTY-FIVE DOLLARS (\$29,175)

Payment to be made as follows:

All material is guaranteed to be as specified. All work to be completed in a workmanlike manner according to standard practices. Any alteration or deviation from above specifications involving extra costs will be executed only upon written orders and will become an extra charge over and above the estimate. All agreements contingent upon strikes, accidents or delays beyond our control. Owner to carry fire, tornado and other	Authorized Signature <u>Carrie McCoun</u>
	Note: This proposal may be withdrawn by us if not accepted within _____ days
ACCEPTANCE OF PROPOSAL - The above prices, specifications and conditions are satisfactory and are hereby accepted. You are authorized to do the work as specified. Payment will be made as outlined above.	Signature <u></u>
Date of Acceptance: <u>06/22/22</u>	Signature _____

SANTA CRUZ CITY SCHOOL DISTRICT

AGENDA ITEM: Fiber Optic Telecom International Proposal for Districtwide Electronic Key Card System Set-Up

MEETING DATE: August 17, 2022

FROM: Jim Monreal, Assistant Superintendent, Business Services

THROUGH: Kris Munro, Superintendent

RECOMMENDATION:

Approve Fiber Optic Telecom International proposal for Districtwide electronic key card system set-up.

BACKGROUND:

This proposal consists of creating and inputting site door data into the Districtwide electronic key card system. This will allow for the issuance of key cards with specific access to appropriate doors are needed. The installation of this system will occur over the course of the first semester of the school year.

DATA STORAGE ARRAY	\$47,458.33 (approved & budgeted)
TELECOMMUNICATION SERVICES EQUIPMENT	\$834,239.83 (approved & budgeted)
NETWORK COORDINATION CONSULTING	\$35,520.00 (approved & budgeted)
KEYCARD CREATION	\$13,246.00 (approved & budgeted)
ROUTER INSTALLATION	\$150,925.55 (approved & budgeted)
MAGICARD PRINTER & PROXY CARDS	\$3,394.55 (approved & budgeted)
DISTRICT WIDE DOOR HARDWARE	\$2,006,429.00 (approved & budgeted)
DISTRICT ROUTERS	\$31,709.46 (approved & budgeted)
KEY CARD SYSTEM SET UP	\$53,280.00 (This agenda Item)
FACILITIES DOOR HARDWARE	\$13,698.68 (agenda item 8.3.21)
KEY CARDS	\$4,140.58 (agenda item 8.3.14)
Estimated Total	\$3,194,041.98

FISCAL IMPACT:

\$53,280.00 TOTAL

Cost Breakdown by Measure:

\$35,697.60 Measure A (Restricted)

\$17,582.40 Measure B (Restricted)

This work is in direct support of the following District goals and their corresponding metrics:

AGENDA ITEM: 8.3.11.

- Goal #2: SCCS will create positive, engaging school environments that promote the development of cognitive skills and the social emotional well-being of all students.
- Goal #5: SCCS will maintain a balanced budget and efficient and effective management.
- Goal #6: SCCS will maintain strong communication and partnership with its diverse community.

Prepared by Trevor Miller, Director, Facility Services

Expanded Scope of Work: Planning, Analysis, and Deployment of Districtwide SCCS Implementation of SA Guardian System

Attention	Mr. Trevor Miller Ms. Tricia Hayes
Organization	Santa Cruz City Schools District (SCCS)
Address	133 Mission Street Suite 100 Santa Cruz, CA 95060
Contact Email	trevormiller@sccs.net thayes@sccs.net
Contact Phone	(831) 429-3410 (831) 201-9602

Planning, analysis, and deployment of Districtwide (approx. 12 sites) SCCS implementation of SA Guardian System

- a) Interfacing personnel databases with Alpha card printer application
- b) Analysis of personnel data for importing into SA Guardian System
- c) Implementation process flow
- d) Work with district personnel to create a key card for every district employee
- e) Create a control data base for key card control for new system
- f) SA Guardian system various facilities planning and batch file uploads
- g) Server updates, door-lock installs and issuing readers
- h) Creating SA Guardian system users, Issuing secure proxy cards
- i) Monitoring devices, troubleshooting
- j) Ongoing onsite support

Project Task Estimate:

T&M rate	\$148.00 / hour
Estimated effort	360 Hours

Sincerely,

Jai Sharma
 Fiber Optic Telecom International
 408.761.9543
jaihowalks@hotmail.com
 831 Gale Drive, Unit 2
 Campbell, CA – 95008

Date: 7/25/2022

SANTA CRUZ CITY SCHOOL DISTRICT

AGENDA ITEM: Geo H Wilson Proposal for Westlake Elementary School Waste Line Repair

MEETING DATE: August 17, 2022

FROM: Jim Monreal, Assistant Superintendent, Business Services

THROUGH: Kris Munro, Superintendent

RECOMMENDATION:

Approve Geo H Wilson proposal for Westlake Elementary School waste line repair.

BACKGROUND:

This proposal consists of the repair of an aging underground waste line at Westlake Elementary School.

FISCAL IMPACT:

\$1,351.20 Measure B Funds (Restricted), representing 0.01% of the overall site budget
\$13,439,288.00 is the total Bond Allocation to Westlake Elementary School

This work is in direct support of the following District goals and their corresponding metrics:

Goal #2: SCCS will create positive, engaging school environments that promote the development of cognitive skills and the social emotional well-being of all students.

Goal #5: SCCS will maintain a balanced budget and efficient and effective management.

Goal #6: SCCS will maintain strong communication and partnership with its diverse community.

Prepared by Trevor Miller, Director, Facility Services



Page 1 of 2

250 HARVEY WEST BLVD., SANTA CRUZ, CA. 95060
Mailing Address: P.O. BOX 1140, SANTA CRUZ, CA 95061
Phone # (831) 423-9522

QUOTATION TO:
Santa Cruz City Schools
536 Palm Street
Santa Cruz, CA 95060
ATTN: Chris Garcia

JOB NAME/ADDRESS:
West Lake Elementary School
1000 High St
Santa Cruz, CA 95060

THE CONDITIONS PRINTED EITHER ON THE REVERSE SIDE OR ATTACHED ARE PART HEREOF.

This work or price quotation does not include detection, abatement, encapsulation or removal of asbestos or products, materials, or equipment containing asbestos.

TIME & MATERIALS (T&M) SCOPE:

- Repair underground waste line damaged while excavating

PRICING SUMMARY:

All work completed on T&M as authorized by Customer:

1. Labor Summary - 7 ST hours @ \$165/hr. = \$1,155
2. Material & tax = \$196.20

"Contractors are required by law to be licensed and regulated by the Contractors' State License Board which has jurisdiction to investigate complaints against contractors if a complaint is filed within three years of the date of the alleged violation. Any questions concerning a contractor may be referred to the Registrar, Contractors' State License Board, P. O. Box 26000, Sacramento, CA 95826."

California State License No. 950443

The total price of this work is \$1,351.20, including all taxes. Terms of payment, unless modified herein, are: 0 down payment and the balance due upon the receipt of invoice.

Your signed acceptance of this Bid Contract within 30 days from **February 18, 2022** shall, upon the acceptance of the Seller, constitute a contract to perform the work described above, including all Terms and Conditions contained herein. Seller shall be defined to mean ACCO Engineered Systems or its assigns. Buyer shall be defined to mean the Owner, Owners/Agent, Builder, Architect, lessees, or any person acting on behalf of any of the foregoing.

Prepared by:
ACCO Engineered Systems on February 18, 2022

Prepared for:
Customer

By: 
Jack Irwin, Project Manager

ACCEPTED for BUYER:

ACCEPTED for SELLER:
By: _____
(Authorized Signature)

By: _____
(Authorized Signature)

Name/Title: _____

Name/Title: _____

Date of Acceptance: _____

Date of Acceptance: _____

Buyers' P.O: _____



1. All work shall be performed during normal working hours unless otherwise stated herein.
2. ACCO Engineered Systems agrees to maintain in full force and effect a Workmen's Compensation Insurance policy and a Comprehensive Liability Insurance policy in substantial amounts to protect all parties to this agreement, furnishing certificates of insurance, if required by Buyer.
3. Buyer shall prepare the premises to permit free movement and erection of materials, providing necessary openings, supports, cutting, patching, necessary public utility and steam services, and pay all fees in accordance with codes and ordinances unless otherwise indicated in this Bid Contract.
4. In the event that the Seller encounters any asbestos product or material in the course of performing its work, the Seller shall have the right to immediately discontinue its work and remove its employees from the project, or that portion of the project wherein such product or materials were encountered, until such time as any hazards connected therewith are abated, encapsulated or removed and/or it is determined that no hazard exists; further, Seller shall receive an extension of time to complete its work and compensation for delays encountered and compensation for any change in the sequence of method or its work occasioned as a consequence of said encounter.
5. ACCO Engineered Systems extends manufacturer's standard warranties on all new equipment, misuse or abuse excepted, for a period not to exceed one year from date of first beneficial use, which shall be defined as the Start-up Date. ACCO Engineered Systems guarantees most, but not all, repaired materials, parts and labor for a period of ninety (90) days from the date of first beneficial use. There are no warranties, expressed or implied, other than the above unless so noted herein.

Seller shall not be liable for any consequential damages including, but not limited to, liquidated damages, loss of rent, interest expense, extended overhead or any other delay damages of any kind, nature or description. It is expressly understood and agreed that the only liability of Seller is to replace defective workmanship or material as herein above set forth.

6. ACCO Engineered Systems will not replace any refrigerant loss caused by defects in the equipment, material, parts, or workmanship furnished under this contract. Replacement of refrigerant due to failure or defects of items furnished by Seller is not included as a part of this agreement.
7. ACCO Engineered Systems shall not be liable for the corrosive or erosive action of liquids and/or gases upon the equipment specified and no part of such equipment shall be deemed defective by reason of its failure to resist physical or chemical action of such elements or items upon such equipment.
8. This agreement shall not be binding until duly accepted by an authorized officer of ACCO Engineered Systems. No person has authority to make or claim any representation, warranty, term, promise, or condition, expressed or implied, statutory or otherwise, which is not expressed herein. This agreement constitutes the entire agreement between the parties and supersedes and revokes any previous agreement, written or oral, with respect to the labor and equipment covered hereby and may not be amended or modified except in writing executed by the parties hereto.
9. Under no circumstances shall the liability of Seller arising out of the sale or erection of the equipment hereunder, or arising out of its use, whether on warranties or otherwise, in any case exceed the lesser of the following: (a) Cost of correcting defects in the equipment or workmanship; or (b) the difference in value between the installation as installed and the cost of the original installation thereof, if installed strictly as in the contract documents set forth. And in no event shall any claims be made by either party against the other for consequential damages.
10. The Seller shall not be bound by any plans and specifications or conditions, existing or otherwise, that have not been presented to or delivered to it for the purpose of submitting this bid, nor shall the Seller be bound by any city ordinances, State laws or other governmental regulations not in effect at the time of submitting this bid, or which had become obsolete and which no longer was enforced by such public body enacting the same.
11. The Seller shall be excused for any delay in completion of this Bid Contract caused by acts of God, including but not limited to, wind, rain, flood, storm, landslide, subsidence and earthquake; acts of neglect of owner or architect or by any employee or agent of either; acts of neglect of separate contractors employed by owner; acts of public utilities or governmental or public bodies or their agents; material shortages; labor trouble, labor slowdowns; strikes; union activity causing a reduction in productivity; fire; casualty; delay in transportation; changes ordered in the work; failure of Buyer to make payments to Seller as required under this Bid Contract, or other causes beyond the reasonable control of Seller, any of which shall automatically entitle Seller to reasonable or necessary extensions of the completion date of the work and to an equitable adjustment of the contract price to compensate Seller for all costs and expenses of additional labor, service, equipment or material and extended overhead resulting from any such delay.

If any of the materials specified are not readily available, the Seller may substitute equally efficient materials or fixtures of generally similar character in lieu of the equipment, materials or fixtures specified, and it shall allow any differential between the original cost of the materials specified and the materials furnished.

In the event of inability to obtain labor at union scale or without paying a premium above such scale, Seller may delay performance until same shall be

obtainable without premium payment or at the option of the Buyer the latter may require the use of materials or labor requiring the payment of such excess cost, but upon condition that the Buyer shall pay such excess.

12. No additional work will be performed unless it is authorized in writing by the Buyer. If the Buyer refuses to sign a written work authorization or change order for the extra work, Seller reserves the right to refuse to perform the extra work.
13. Should either party hereto bring suit in court to enforce the terms hereof, any judgment awarded shall include court costs and reasonable attorney's fees to the successful party.
14. Seller assumes no responsibility for the design on those jobs where Seller prepares working or shop drawings from designs furnished by others. Seller assumes no responsibility whatsoever for design or operative end result under any contract unless there is affirmatively stated on the obverse side of this Bid Contract, a direct undertaking on Seller's part so to do.
15. Seller may suspend further performance under this Bid Contract upon three (3) days written notice to the Buyer in the event the Buyer is in breach of this Bid Contract for breach other than non-payment. Notice need not be given if work is suspended due to non-payment or due to the failure of the Buyer to pay for change orders as provided herein. In the event Seller elects to suspend performance, Seller shall be entitled to remobilization costs, including profit and overhead, upon the Buyer bringing payments current or issuing proper change orders for extra work. Such costs will equal actual losses sustained by Seller in terminating and restarting work.
16. This contract is entered into upon the understanding that in the prosecution of any work herein specified Seller will be allowed sufficient time for the performance of said work on the basis of a normal eight-hour day, and in the event that Buyer or any subcontractor require Seller to perform such labor on an overtime basis, then such additional expense of every kind and character as Seller may be required to incur on account of said overtime labor, shall constitute an additional charge herein.
17. It is agreed that Buyer is to provide without cost to Seller, proper hoisting conveyances and scaffolding (including the use of engineer) at times so as to not delay Seller's part of the work, unless otherwise indicated in this proposal.
18. Any loss or damage to Seller's work, materials or equipment occurring at the site of the project occasioned by fire, flood, earthquake, windstorm, riot or civil commotion shall be protected by Builders Risk Insurance procured by the contractor or owner without cost to Seller and Seller shall receive a proportionate share of the amount of any payment loss under any such policy or policies according as Seller's interest may appear.
19. Notwithstanding any provision in the plans, specifications, contract between prime contractor and owner, general conditions, or any contract documents executed by and between contractor and owner having to do with the subject now stated, Seller shall not be liable for the cost of correcting defects occasioned by the acts or omissions of employees of other subcontractors, the prime contractor, owner or any segregated contractor, to work performed by Seller. Before Seller proceeds with any corrective work to repair such damage, the prime contractor, or other person contracting with Seller in this Bid Contract, shall give Seller an unequalled instruction to proceed with the work upon their responsibility to compensate Seller therefor as an extra.
20. The Seller expressly reserves the right to assign all or any portion of its rights and/or duties under this Bid Contract with or without notice to the Buyer herein.
21. In the event of a conflict between the terms and conditions of this Bid Contract and terms and conditions stated in the plans and specifications, or any other contract document, including the prime contract between owner and prime contractor, the terms of this Bid Contract shall govern.
22. If, in Seller's opinion, Buyer's credit becomes impaired, Seller may, at its option, suspend work and deliveries under this contract until it has received full settlement or security for services rendered and is satisfied as to Buyer's credit for further shipments. If Buyer fails or refuses to make such payment, or give such security, then the full amount due under this contract at such time, for labor and material and/or equipment furnished shall immediately become due and payable and Seller shall have the right and the option to terminate this agreement. In the event that a suspension of this contract is required because of Buyer's doubtful credit, an extension of the time fixed for the performance of this contract equal to the time of such suspension, shall automatically occur. If legal action is filed to effect collection of any sums due hereunder, Seller shall be entitled to reasonable attorney fees in addition to all other damages found to be due hereunder.

ACCEPTED for BUYER

By: _____ (Authorized Signature)

Name/Title: _____

Date of Acceptance: _____

SANTA CRUZ CITY SCHOOL DISTRICT

AGENDA ITEM: Hancock Park & DeLong, Inc. Change Order #1 for Grant and Consulting Services

MEETING DATE: August 17, 2022

FROM: Jim Monreal, Assistant Superintendent, Business Services

THROUGH: Kris Munro, Superintendent

RECOMMENDATION:

Ratify Hancock Park & DeLong, Inc. change order #1 for grant and consulting services.

BACKGROUND:

This proposal consists of additional consulting services associated with the California Department of Education approval of plans as required to pursue modernization funding from the State of California for Gault Elementary Schools new classroom building, as well as updated eligibility at various sites throughout the District. This issue arose over the summer break and required immediate action.

FISCAL IMPACT:

\$17,793.75 Total

Cost Breakdown by fund:

\$5,556.81 Measure A District Set-Aside (Restricted)

\$12,236.94 Measure B District Set-Aside (Restricted)

This work is in direct support of the following District goals and their corresponding metrics:

Goal #2: SCCS will create positive, engaging school environments that promote the development of cognitive skills and the social emotional well-being of all students.

Goal #5: SCCS will maintain a balanced budget and efficient and effective management.

Goal #6: SCCS will maintain strong communication and partnership with its diverse community.

Prepared by Trevor Miller, Director, Facility Services

AGENDA ITEM: 8.3.13.



July 7, 2022

Santa Cruz City Schools
Attn: Trevor Miller and Tricia Hayes
Maintenance, Operations, Transportation & Facilities Dept.
133 Mission St, Suite 100
Santa Cruz, CA 95060

RE: CHANGE ORDER REQUEST TO P.O. #19-01953

Dear Mr. Miller and Ms. Hayes:

Hancock Park & DeLong, Inc. (HPD) respectfully requests an increase to the elementary portion of Purchase Order #19-01953 for the Gault Elementary School portable replacement project (PTN 69815-54 and DSA A#01-119989). This project and work were not anticipated or considered at the time HPD's proposal was drafted in 2018; thus, the initial proposal is insufficient to cover these services. We respectfully request the purchase order to be increased a minimum of \$8,293.75 for services 1, 2, 3 & 5 below. If the district wishes to pursue new construction grants for this project as well, the purchase order should be increased a total of \$17,793.75 instead, as explained in #4 below. The following services are proposed to be provided:

- 1) Update modernization eligibility baselines for new bond efforts per Trevor's request in email of 4.25.22 (attached) - \$393.75
- 2) Request the California Department of Education's approval of the plans - \$3,000
- 3) Complete an application for modernization funding - \$3,500
- 4) As explained in HPD's email of May 5, 2022 (attached), the district can consider requesting new construction grants for the Gault ES portable replacement project. To do so would require the district to establish its new construction eligibility baseline and the completion of an application for new construction funding.
 - \$6,000 for the eligibility baseline
 - \$3,500 for the application for funding (this would only be charged if the district is able to file both an application for new construction and modernization funding)
- 5) If the project application(s) are funded, additional services will be provided, including but not limited to, answering questions resulting from the Office of Public School Construction's review of the application(s), completing the request for apportionment and release of funds, and assistance with project expenditure reporting and audit, if needed - \$1,400 (estimated based on an hourly rate of \$175/hr and 8 hours)

The funding of this/these applications will be dependent upon an infusion of state monies into the School Facility Program beyond the \$1.3 billion in state General Fund monies added by the approved 2022-23 Budget.

Thank you for your consideration. With gratitude,

Chris DeLong
President

1722 J St, Suite 224
Sacramento, CA 95811
916.832.1047
www.HPDschools.com

SANTA CRUZ CITY SCHOOL DISTRICT

AGENDA ITEM: ID Distributors Quote Districtwide Electronic Key Cards

MEETING DATE: August 17, 2022

FROM: Jim Monreal, Assistant Superintendent, Business Services

THROUGH: Kris Munro, Superintendent

RECOMMENDATION:

Approve ID Distributors quote for Districtwide electronic key cards.

BACKGROUND:

The Board previously approved and the District purchased hardware for a keyless electronic lock system. This system allows for additional safety measures that include the ability to lockdown the campus remotely. In addition, it will give everyone in the District their own personal electronic ID card/key programmed to the appropriate doors where they need access. This proposal consists of the purchase of the key cards. This is part of the Districtwide plan for site security and key management. This issue arose over the summer break and required immediate action.

DATA STORAGE ARRAY	\$47,458.33 (approved & budgeted)
TELECOMMUNICATION SERVICES EQUIPMENT	\$834,239.83 (approved & budgeted)
NETWORK COORDINATION CONSULTING	\$35,520.00 (approved & budgeted)
KEYCARD CREATION	\$13,246.00 (approved & budgeted)
ROUTER INSTALLATION	\$150,925.55 (approved & budgeted)
MAGICARD PRINTER & PROXY CARDS	\$3,394.55 (approved & budgeted)
DISTRICT WIDE DOOR HARDWARE	\$2,006,429.00 (approved & budgeted)
DISTRICT ROUTERS	\$31,709.46 (approved & budgeted)
KEY CARD SYSTEM SET UP	\$53,280.00 (agenda item 8.3.11)
FACILITIES DOOR HARDWARE	\$13,698.68 (agenda item 8.3.21)
KEY CARDS	\$4,140.58 (This agenda Item)
Estimated Total	\$3,194,041.98

FISCAL IMPACT:

\$4,140.58 Total

Cost Breakdown by fund:

\$2,774.19 Measure A (Restricted)

\$1,366.39 Measure B (Restricted)

AGENDA ITEM: 8.3.14.

This work is in direct support of the following District goals and their corresponding metrics:

Goal #2: SCCS will create positive, engaging school environments that promote the development of cognitive skills and the social emotional well-being of all students.

Goal #5: SCCS will maintain a balanced budget and efficient and effective management.

Goal #6: SCCS will maintain strong communication and partnership with its diverse community.

Prepared by Trevor Miller, Director, Facility Services



DISTRIBUTORS

QUOTE

Santa Cruz City Schools

Date
12 Jul 2022

ID Distributors
1100 Bellevue Way NE

Expiry
10 Aug 2022

Suite 8A - #895
Bellevue, WA 98004

Quote Number
QU-220712SCCS

Reference
Magicard/UltraCard

Prepared for Trevor Miller

Director of Facility Services
Santa Cruz City Schools
536 Palm Street
Santa Cruz, CA 95060
(831) 429-3904
trevormiller@sccs.net

Description	Quantity	Unit Price	Tax	Amount USD
1386XXXXX ISOProx II 35 Bit Prox 125kHz ISO PVC	10.00	379.00	Tax on Sales	3,790.00
Free UPS shipping	1.00	0.00		0.00
Subtotal				3,790.00
TOTAL USD				3,790.00
9.25% tax				350.85
TOTAL				4,140.58

7/26/22

SANTA CRUZ CITY SCHOOL DISTRICT

AGENDA ITEM: Leach Group Change Order for New Switch Gear Inspections

MEETING DATE: August 17, 2022

FROM: Jim Monreal, Assistant Superintendent, Business Services

THROUGH: Kris Munro, Superintendent

RECOMMENDATION:

Approve Leach Group change order for new switch gear inspections.

BACKGROUND:

These change order consists of additional inspection services, as required by the Division of State Architect, for the Mission Hill Middle School, Westlake Elementary School and Santa Cruz High School new switchgear projects. This issue arose over the summer break and required immediate action.

FISCAL IMPACT:

\$31,200.00 TOTAL

Cost Breakdown by Site:

\$10,400.00 Measure A Funds (Restricted), Santa Cruz High School

\$10,400.00 Measure A Funds (Restricted), Mission Hill Middle School

\$10,400.00 Measure B Funds (Restricted), Westlake Schools

This work is in direct support of the following District goals and their corresponding metrics:

Goal #2: SCCS will create positive, engaging school environments that promote the development of cognitive skills and the social emotional well-being of all students.

Goal #5: SCCS will maintain a balanced budget and efficient and effective management.

Goal #6: SCCS will maintain strong communication and partnership with its diverse community.

Prepared by Trevor Miller, Director, Facility Services

AGENDA ITEM: 8.3.15.

Proposal

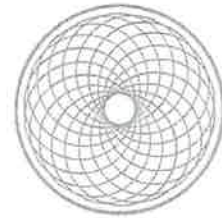

LEACH GROUP INC.

946 Channel Drive
Montecito, Ca 93108
T 661-599-5393
leachgroup@me.com

Attention : Bartos Architecture

Date : 07/11/22

PROJECT TITLE: Mission Hill Middle School Switch Gear Replacement.

PROJECT DESCRIPTION: Onsite Inspection

P.O. NUMBER: N/A

Description	Cost
Onsite inspection hourly rate. (Three Hour Minimum)	\$ 130.00
Total hours not to exceed per this project (80 hours)	\$ 10,400.00
The price quoted above is good for thirty days fro date given. Work to be completed in second half of 2021	
Total	\$ 10,400.00

Term and conditions : These projections are based on the contractor performing per the approved schedule. The price quoted is good for thirty days form date given.

Proposal

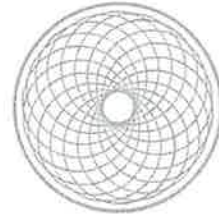

LEACH GROUP INC.

946 Channel Drive
 Montecito, Ca 93108
 T 661-599-5393
leachgroup@me.com

Attention : Bartos Architecture

Date : 07/11/22

PROJECT TITLE: Santa Cruz High School Switch Gear Replacement.

PROJECT DESCRIPTION: **Onsite Inspection**

P.O. NUMBER: N/A

Description	Cost
Onsite inspection hourly rate. (Three Hour Minimum)	\$ 130.00
Toal hours not to exceed per this project (80 hours)	\$ 10,400.00
The price quoted above is good for thirty days fro date given. Work to be completed in first half of 2021	
Total	\$ 10,400.00

Term and conditions : These projections are based on the contractor performing per the approved schedule. The price quoted is good for thirty days form date given.

[Handwritten Signature]
 07/11/22

SANTA CRUZ CITY SCHOOL DISTRICT

AGENDA ITEM: Lewis and Tibbitts Inc. Change Order #4 for Mission Hill Middle School Switchgear Replacement

MEETING DATE: August 17, 2022

FROM: Jim Monreal, Assistant Superintendent, Business Services

THROUGH: Kris Munro, Superintendent

RECOMMENDATION:

Approve Lewis and Tibbitts Inc. change order #4 for Mission Hill Middle School switchgear replacement.

BACKGROUND:

This change order includes the installation of a redwood header board, modifications to handrails, and the replacement of an old breaker for the elevator. The original plans did not account for the header board and handrails. During electrical testing the contractor identified that the breaker on the elevator was failing. The previously approved contract amount was \$936,454.23 and the new total contract, including this change order, will be \$945,954.23.

FISCAL IMPACT:

Change Order #4 \$9,500.00 (1.01% increase to the contract), Measure A Funds (Restricted)

This work is in direct support of the following District goals and their corresponding metrics:

Goal #2: SCCS will create positive, engaging school environments that promote the development of cognitive skills and the social emotional well-being of all students.

Goal #5: SCCS will maintain a balanced budget and efficient and effective management.

Goal #6: SCCS will maintain strong communication and partnership with its diverse community.

Prepared by Trevor Miller, Director, Facility Services

AIA® Document G701™ – 2017

Change Order

PROJECT: <i>(name and address)</i> MHMS Switchgear Replacement 425 King Street Santa Cruz, CA	CONTRACT INFORMATION: Contract For: Switchgear Upgrades Date: 02/15/21	CHANGE ORDER INFORMATION: Change Order Number: 004 Date: 7/21/2022
OWNER: <i>(name and address)</i> Santa Cruz City Schools 133 Mission St #100 Santa Cruz, CA 95060	ARCHITECT: <i>(name and address)</i> Mark E. Bartos 300 8th Ave Suite 202 San Mateo, CA 94401	CONTRACTOR: <i>(name and address)</i> Lewis & Tibbitts, Inc 1470 Industrial Ave San Jose, CA 95112

THE CONTRACT IS CHANGED AS FOLLOWS:

(Insert a detailed description of the change and, if applicable, attach or reference specific exhibits. Also include agreed upon adjustments attributable to executed Construction Change Directives.)

ADD \$3,800.00 (zero days requested) - Supply and install redwood header board along the southern perimeter of the jobsite.

ADD \$4,500.00- (Zero day requested) - Modification of handrails

ADD \$1,200.00- (Zero day requested)- Replace the elevator breaker with a shunt trip relay

Total ADD: \$9,500.00

The original Contract Sum	was	\$	<u>874,100.00</u>
The net change by previously authorized Change Orders		\$	<u>62,354.23</u>
The Contract Sum	prior to this Change Order was	\$	<u>936,454.23</u>
The Contract Sum	will be increased by this Change Order in the amount of	\$	<u>9,500.00</u>
The new Contract Sum	, including this Change Order, will be	\$	<u>945,954.23</u>
The Contract Time will be unchanged by	zero (0) days.		
The new date of Substantial Completion will be	7/30/2022		

NOTE: *This Change Order does not include adjustments to the Contract Sum or Guaranteed Maximum Price, or the Contract Time, that have been authorized by Construction Change Directive until the cost and time have been agreed upon by both the Owner and Contractor, in which case a Change Order is executed to supersede the Construction Change Directive.*

NOT VALID UNTIL SIGNED BY THE ARCHITECT, CONTRACTOR AND OWNER.

Bartos Architecture
ARCHITECT *(Firm name)*

DocuSigned by:
Mark Bartos
SIGNATURE

Mark Bartos, President
PRINTED NAME AND TITLE

8/2/2022

DATE

Lewis & Tibbitts, Inc
CONTRACTOR *(Firm name)*

DocuSigned by:
Buster Segura
SIGNATURE

Buster Segura, President
PRINTED NAME AND TITLE

8/2/2022

DATE

Santa Cruz City Schools
OWNER *(Firm name)*

SIGNATURE

PRINTED NAME AND TITLE

DATE

AIA Document G701™ – 2017. Copyright © 1979, 1987, 2000, 2001 and 2017 by The American Institute of Architects. All rights reserved. **WARNING:** This AIA® Document is protected by U.S. Copyright Law and International Treaties. Unauthorized reproduction or distribution of this AIA® Document, or any portion of it, may result in severe civil and criminal penalties, and will be prosecuted to the maximum extent possible under the law. This document was created on 06/21/2022 19:47:28 under the terms of AIA Documents-on-Demand™ Order No. 2114336586, and is not for resale. This document is licensed by The American Institute of Architects for one-time use only, and may not be reproduced prior to its completion.



1470 Industrial Ave
San Jose, CA 95112
Phone: (408) 925-0220 Fax: (408) 925-0240

Lic. #281666 General A, C-10, C-36, C-42
WE ARE A UNION CONTRACTOR

Change Order Request #12

June 20, 2022

Curtis,

This is a Change Order Request for additional costs to supply and install a redwood header board along the southern perimeter of the jobsite.

Reason for request:

Additional labor, material, and equipment costs.

Project:	Subcontractor:
Mission Hill MS – Switchgear Replacement	Lewis & Tibbitts, Inc.
425 King Street	1470 Industrial Ave
Santa Cruz, CA 95060	San Jose, CA 95112

L&T COR #: 12
L&T Job #: 21259H

Summary:

Reason for Change	Description	Qty	UM	Unit	EXT.
Add:	Supply & Install Redwood Header Board	1	LS	\$3,800.00	\$3,800.00
Total This Request:					\$3,800.00

If you have any questions, please do not hesitate to contact us.

Regards,

Taro Kyllonen

Quotation



Economy Lumber Company
720 Camden Avenue
Campbell, California 95008

Invoice Address

Quote No **234265**
Quote Date **06/20/2022**
Customer Reference Cash Customer taro
Contact
Phone 408-892-9469
Delivery 06/21/2022
Taken By Jack Sturgis

P: 408.378.5231
F: 408.378.0258



Estimate

Page 1 of 1

Special Instructions	Notes

Line	Product Code	<input checked="" type="checkbox"/>	Qty/Footage	Description	Price	Per	Total
1	2218PTSB		3 BNDL	2X2 18" P.T. Stakes 25 pc Bundle	38.49	BNDL	115.47
2	2612RR		14 ea	2X6 12' Redwood Const Hrt Rough	3.70	If	621.60

Total Amount	\$737.07
Sales Tax	\$69.10
CA Lumber Tax	\$6.22
Quotation Total	\$812.39
Balance Due	\$812.39

Review this estimate carefully. We agree to furnish only the items and quantities named and described hereon. Prices are based upon quantities listed. Any variation, deletion, or addition may affect prices on all items. Prices on this estimate will be protected provided that this estimate is accepted within 5 working days from the date of this estimate and all materials on this estimate are delivered or paid within 15 days. To ensure you receive correct pricing please reference this estimate number when ordering.



1470 Industrial Ave
San Jose, CA 95112
Phone: (408) 925-0220 Fax: (408) 925-0240

Lic. #281666 General A, C-10, C-36, C-42
WE ARE A UNION CONTRACTOR

Change Order Request #13

July 11, 2022

Curtis,

This is a Change Order Request for additional costs to modify existing staircase handrails per the sketch provided by Bartos Architecture. Includes core drilling into concrete/asphalt for setting of handrail posts and L&T supervision.

Reason for request:

Additional subcontractor, labor and equipment costs.

Project:	Subcontractor:
Mission Hill MS – Switchgear Replacement	Lewis & Tibbitts, Inc.
425 King Street	1470 Industrial Ave
Santa Cruz, CA 95060	San Jose, CA 95112

L&T COR #: 13
L&T Job #: 21259H

Summary:

Reason for Change	Description	Qty	UM	Unit	EXT.
Add:	Staircase Handrail Modifications	1	LS	\$4,500.00	\$4,500.00
Total This Request:					\$4,500.00

If you have any questions, please do not hesitate to contact us.

Regards,

Taro Kyllonen

DSA Application ID of Existing Building:
 Main Classroom Building
 DSA Appl. No. Original Building 1930-none
 DSA Appl. No. Rehab Oct. 1974 - 37316

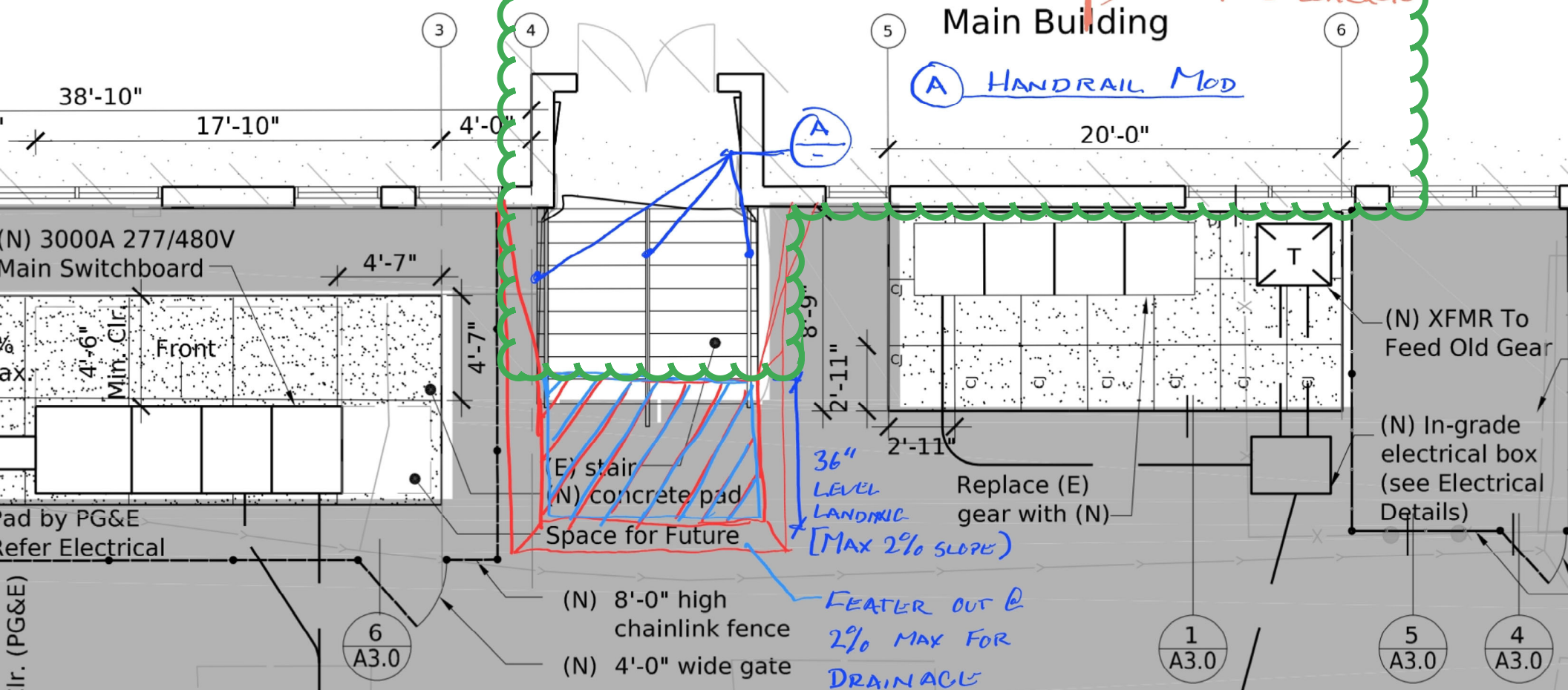
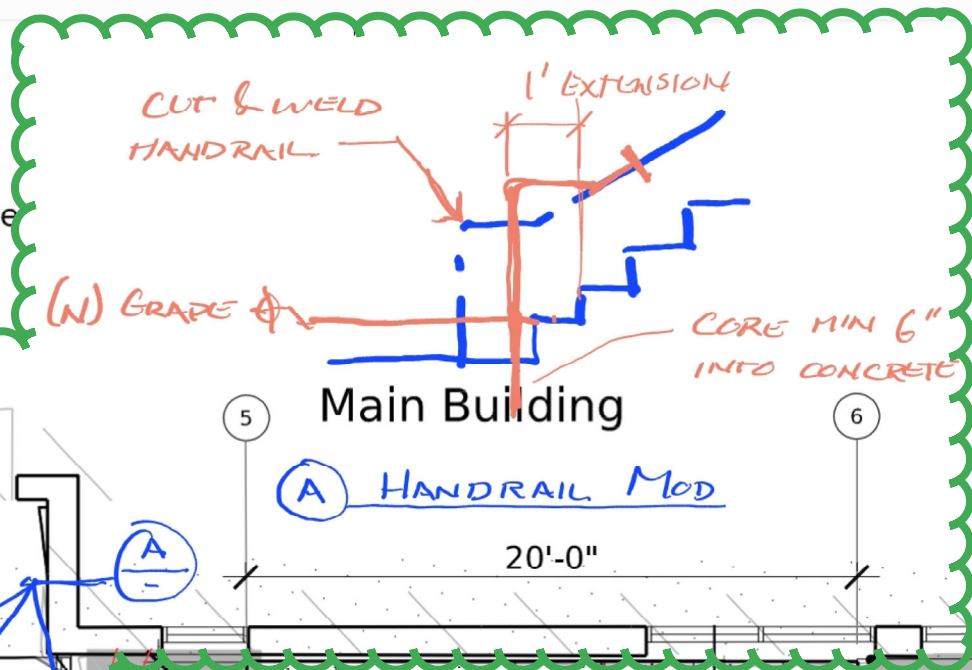

(A) HANDRAIL MOD

36"
 LEVEL
 LANDSCAPE
 [MAX 2% SLOPE]

FEATHER OUT @
 2% MAX FOR
 DRAINAGE

(N) 8'-0" high
 chainlink fence
 (N) 4'-0" wide gate

Replace (E)
 gear with (N)

(N) XFMR To
 Feed Old Gear
 (N) In-grade
 electrical box
 (see Electrical
 Details)



Quotation

ROADWAY STEEL & FABRICATION, INC.

June 30, 2022

1650 GRANT STREET
SANTA CLARA, CA 95050
PH. (408) 639-0996

Customer: LEWIS & TIBBITTS, INC.
Attention: TARO KYLLONEN
Tel / Email: 408-892-9469

**PRICES SUBJECT TO REVIEW AFTER
30 DAYS**

Salesperson	Job	Lead Time	Payment Terms	FOB
ROBERT GARCIA	MISSION HILL SCHOOL	2-3 DAYS	NET 30 DAYS	RSF

Qty	Unit	Description	Unit Price	Ext Price
1	LOT	MODIFY 3 EACH 1-1/2 SCH 40 PIPE STAIR RAILS PER CUSTOMER INSTRUCTION	2,475.00	2,475.00

PLEASE ADD SALES TAX AND FREIGHT IF APPLICABLE!

**Quote based on quantities listed above, any changes in quantity may require a second look and possible requote.*

Subtotal	2,475.00
Sales Tax	225.84
Freight	
TOTAL	\$2,700.84

We accept Visa, MasterCard, American Express & Discover!

This is a quotation on the goods named, subject to the conditions noted below:

Excludes field measuring of any kind, shop drawings, unloading or other handling, third party welding inspection (fees or otherwise), any special finishes or any item not shown above. Roadway Steel does not assume design responsibility for products supplied. If we propose something, customer should have an engineer verify what has been suggested.

**Terms Net 30 with approved credit*

**Processing fees will apply to all credit card purchases*

To accept this quotation, sign here and return: _____

THANK YOU FOR YOUR BUSINESS!



1470 Industrial Ave
San Jose, CA 95112
Phone: (408) 925-0220 Fax: (408) 925-0240

Lic. #281666 General A, C-10, C-36, C-42
WE ARE A UNION CONTRACTOR

Change Order Request #14

July 11, 2022

Curtis,

This is a Change Order Request for additional costs to replace the elevator breaker with a shunt trip relay. The elevator breaker did not have the required shunt trip function.

Reason for request:

Additional subcontractor costs.

Project:	Subcontractor:
Mission Hill MS – Switchgear Replacement	Lewis & Tibbitts, Inc.
425 King Street	1470 Industrial Ave
Santa Cruz, CA 95060	San Jose, CA 95112

L&T COR #: 14
L&T Job #: 21259H

Summary:

Reason for Change	Description	Qty	UM	Unit	EXT.
Add:	Install Shunt Trip Relay	1	LS	\$1,200.00	\$1,200.00
Total This Request:					\$1,200.00

If you have any questions, please do not hesitate to contact us.

Regards,

Taro Kyllonen

Taro Kyllonen

From: Christopher Stark <cps@jmelectric.com>
Sent: Friday, July 8, 2022 11:24 AM
To: Taro Kyllonen; 'Adrien Antosz'; srr@jmelectric.com
Subject: Mission hills - Breaker issue - RFI - Urgent
Attachments: Breaker - Elevator - Mission Hills.jpg

Importance: High

Taro,

Our electrician has just identified a problem with one of the breakers in the DPD panel. It is the 125 Amp elevator breaker, and it does not have a shunt trip function, that is normally required. It was not in the plans, nor was it in the submittals. We need approval to replace the breaker with a shunt trip type breaker, unless we can install a shunt trip relay. I am looking into it right now. The impact is that they will not be able to use the elevator until this is done. The work will be done as a change order.

Please process this request urgently.

Cheers,
Christopher Stark
JM Electric
Salinas, CA
Office: 831-422-7819
Cell: 631-655-7963

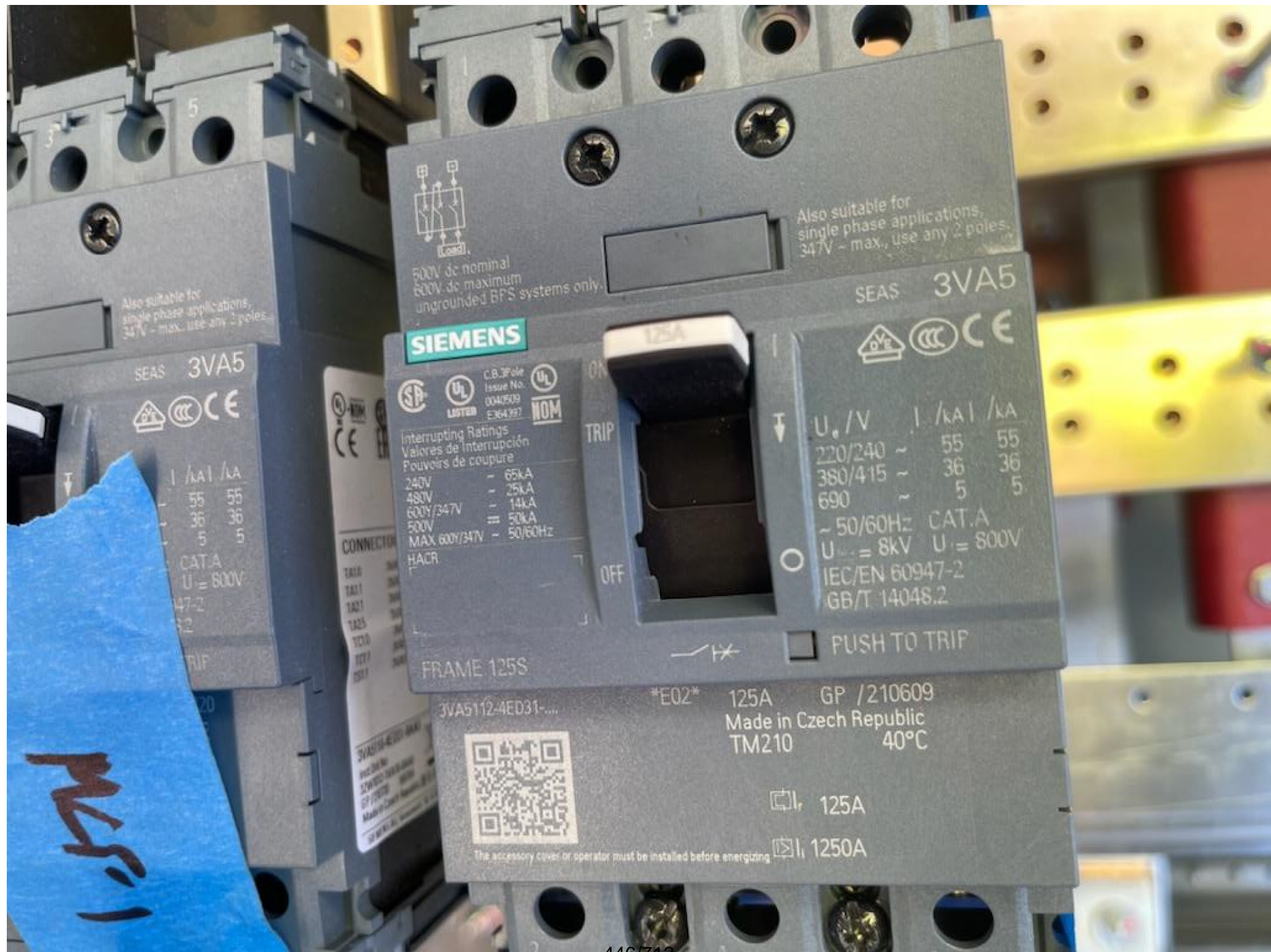

Also suitable for single phase applications, 247V - max., use any 2 poles.

SEAS 3VA5



I / kA	I _{ka}
55	55
36	36
5	5

CAT.A
U = 800V

47-2

TRIP

PVS-1



500V de nominal
600V de maximum
ungrounded BPS systems only.

Also suitable for single phase applications, 347V - max., use any 2 poles.

SEAS 3VA5



SIEMENS



Interrupting Ratings
Valores de Interrupción
Pouvoirs de coupure

240V	-	65kA
480V	-	25kA
600V/347V	-	14kA
500V	=	50kA
MAX 600V/347V	-	50/60Hz

HACR

TRIP

OFF

U _n / V	I / kA	I _{ka}
220/240 ~	55	55
380/415 ~	36	36
690 ~	5	5

~ 50/60Hz CAT.A
U_{max} = 8kV U = 800V

IEC/EN 60947-2
GB/T 14048.2

PUSH TO TRIP

FRAME 125S

3VA5112-4ED31-....

E02

125A GP / 210609

Made in Czech Republic

TM210 40°C



125A

1250A

The accessory cover or operator must be installed before energizing

SANTA CRUZ CITY SCHOOL DISTRICT

AGENDA ITEM: MBC Enterprises Inc. Change Order #4 for Santa Cruz High School Underground Utility Replacement

MEETING DATE: August 17, 2022

FROM: Jim Monreal, Assistant Superintendent, Business Services

THROUGH: Kris Munro, Superintendent

RECOMMENDATION:

Approve MBC Enterprises Inc. change order #4 Santa Cruz High School underground utility replacement.

BACKGROUND:

This change order consists of the recovery of costs related to the contractor damaging the water line during construction. The previously approved contract amount was \$809,022.47 and the new total contract, including this change order, will be \$802,577.06 which represents the recovery of \$6,445.41 to the District.

FISCAL IMPACT:

Change Order #4 -\$6,445.41 (% decrease to the contract), Measure A Funds (Restricted)

This work is in direct support of the following District goals and their corresponding metrics:

Goal #2: SCCS will create positive, engaging school environments that promote the development of cognitive skills and the social emotional well-being of all students.

Goal #5: SCCS will maintain a balanced budget and efficient and effective management.

Goal #6: SCCS will maintain strong communication and partnership with its diverse community.

Prepared by Trevor Miller, Director, Facility Services



AIA® Document G701™ – 2017

Change Order

PROJECT: <i>(name and address)</i> SCHS Utility Project Santa Cruz High School	CONTRACT INFORMATION: Contract For: Utility Upgrades Date: 04/26/2021	CHANGE ORDER INFORMATION: Change Order Number: 004 Date: 06/29/2022
OWNER: <i>(name and address)</i> Santa Cruz City Schools 133 Mission St Suite 100 Santa Cruz, CA 95060	ARCHITECT: <i>(name and address)</i> Mark E. Bartos, Architect 1730 S Amphlett Blvd Suite 225 San Mateo, CA 94402	CONTRACTOR: <i>(name and address)</i> MBC Enterprises Inc. 16601 Gothard St #G Huntington Beach, CA 92647

THE CONTRACT IS CHANGED AS FOLLOWS:



(Insert a detailed description of the change and, if applicable, attach or reference specific exhibits. Also include agreed upon adjustments attributable to executed Construction Change Directives.)

- (SUBTRACT- \$4,767.48) Emergency Water Line Repair
- (SUBTRACT- \$627.75) Food Service SCCS invoice
- (SUBTRACT- \$1050.18) ACE Portable Lavatory Rental

The original Contract Sum	was	\$	<u>528,900.00</u>
The net change by previously authorized Change Orders		\$	<u>280,132.47</u>
The Contract Sum	prior to this Change Order was	\$	<u>809,022.47</u>
The Contract Sum	will be decreased by this Change Order in the amount of	\$	<u>6,445.41</u>
The new Contract Sum	, including this Change Order, will be	\$	<u>802,577.06</u>
The Contract Time will be increased by zero (0) days.			
The new date of Substantial Completion will be 12/31/21			

NOTE: This Change Order does not include adjustments to the Contract Sum or Guaranteed Maximum Price, or the Contract Time, that have been authorized by Construction Change Directive until the cost and time have been agreed upon by both the Owner and Contractor, in which case a Change Order is executed to supersede the Construction Change Directive.

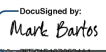
NOT VALID UNTIL SIGNED BY THE ARCHITECT, CONTRACTOR AND OWNER.

<u>Bartos Architecture, Inc.</u> ARCHITECT <i>(Firm name)</i>	<u>MBC Enterprises Inc.</u> CONTRACTOR <i>(Firm name)</i>	<u>Santa Cruz City Schools</u> OWNER <i>(Firm name)</i>
 SIGNATURE	 SIGNATURE	 SIGNATURE
<u>Mark Bartos, Principal</u> PRINTED NAME AND TITLE	<u>Rudy Sultan, President</u> PRINTED NAME AND TITLE	 PRINTED NAME AND TITLE
<u>8/2/2022</u> DATE	<u>8/2/2022</u> DATE	 DATE

AIA Document G701™ – 2017. Copyright © 1979, 1987, 2000, 2001 and 2017 by The American Institute of Architects. All rights reserved. WARNING: This AIA® Document is protected by U.S. Copyright Law and International Treaties. Unauthorized reproduction or distribution of this AIA® Document, or any portion of it, may result in severe civil and criminal penalties, and will be prosecuted to the maximum extent possible under the law. This document was created on 10/05/2021 13:45:19 under the terms of AIA Documents-on-Demand™ Order No. 2114247958, and is not for resale. This document is licensed by The American Institute of Architects for one-time use only, and may not be reproduced prior to its completion.

MECHANICAL

GEO. H. WILSON
CONTRACTORS

INVOICE

55908

Geo.H.Wilson Mechanical Job #

70510578

888 E. Walnut Street, Pasadena, CA 91101-1897
Phone: 818.244.6571

CA License #120696 | WA License #ACCOES1971DU
Established 1934

www.accoes.com

Principal Offices

Pasadena | San Leandro | San Diego | Orange County | Sacramento |
Seattle | Santa Cruz | Commerce | Vacaville | Bakersfield | Boise | Fresno

Job: SCHS Emergency Water Line Repa
415 Walnut Ave
Santa Cruz, CA 95060
PO #PO22-01473

ACCO REPRESENTATIVE

Irwin, Jack I

B 302407
I Santa Cruz City Schools District
L 133 Mission St
L Attn: Accounts Payable
E Ste 100
D Santa Cruz, CA 95060
T
O

Invoice Date: 01/18/2022

ORIGINAL CONTRACT PRICE	\$4,767.48
CHANGE ORDERS TO DATE	\$0.00
TOTAL CONTRACT SUM TO DATE	\$4,767.48
WORK COMPLETED TO DATE	\$4,767.48
LESS RETAINAGE TO DATE	\$0.00
TOTAL EARNED LESS RETAINAGE	\$4,767.48
LESS PREVIOUS BILLINGS	\$0.00
NET AMOUNT DUE THIS BILLING	\$4,767.48

Construction progress this period as detailed on the attached.

NOTE: This billing is for the current period only. Previous billings which have not been paid are due, in addition to the above amount.

Please send check and correspondence to the address shown above, referencing Geo.H.Wilson Mechanical's Job & Invoice numbers.

ACE PORTABLE SERVICES
103 VICTORIA LANE
APTOS, CA 95003



Invoice

Bill To:

SANTA CRUZ CITY SCHOOLS
RE: SANTA CRUZ HIGH
133 MISSION ST, STE 100
SANTA CRUZ, CA 95060

Ship To:

415 WALNUT AVE
SANTA CRUZ, CA 95062

COMMERCIAL - RESIDENTIAL - INDUSTRIAL - CONSTRUCTION - SPECIAL EVENTS

Date		PORTABLE TOILET, FENCE AND DUMPSTER RENTALS EVENT TRAILERS - ADA HANDICAPPED UNITS	Invoice #		
12/9/2021			173809		
P.O. No.	PROJECT	Terms	DURATION		
P022-00170	WALNUT AVE 415	DUE ON RECEIPT	ONGOING		
Description		Quantity	Serviced	Rate	Amount
RENTAL FEE FOR STANDARD PORTABLE TOILET		4		10.00	40.00
CLEANING SERVICE		4		85.00	340.00
All cleaning & maintenance services are OPTIONAL and California use tax will be added to all rental as applicable by law.					
HAND-WASH STATION		5		10.00	50.00
CLEANING SERVICE		5		85.00	425.00
All cleaning & maintenance services are OPTIONAL and California use tax will be added to all rental as applicable by law.					
ADA HANDICAPPED PORTABLE TOILET		1		20.00	20.00
CLEANING SERVICE		1		165.00	165.00
All cleaning & maintenance services are OPTIONAL and California use tax will be added to all rental as applicable by law.					
<i>Paul Zick 12/15/21</i>					
PLEASE REMIT: ACE PORTABLE SERVICES 103 VICTORIA LN. APTOS CA. 95003			Sales Tax (9.25%)		\$10.18
			Total		\$1,050.18
			Balance Due		\$1,050.18

408-297-2345 - 831-465-0406 - FAX 831-479-7011 ACEPORTABLES@YAHOO.COM

SANTA CLARA - MONTEREY - SANTA CRUZ - SAN BENITO COUNTIES

SANTA CRUZ CITY SCHOOLS
Surf City Café
133 Mission St. Ste 100
Santa Cruz, CA 95060



INVOICE

Invoice #: 2122-38
Date: 1/4/2022
Bill to: Trevor Miller
SC High water shut off In October 2021

<u>Quantity</u>	<u>Item Description</u>	<u>Unit Price</u>	<u>Extended</u>
75 Cases	Water	\$8.37	\$627.75

Total **\$627.75**

Please remit payment payable to:

SCCS Food Services
310 La Fonda Ave
Santa Cruz, CA. 95062

THANK YOU

Contact Amy Hedrick-Farr 831-429-3850

SANTA CRUZ CITY SCHOOL DISTRICT

AGENDA ITEM: Monterey Peninsula Engineering Change Order #1 Maintenance Facility Yard Repaving

MEETING DATE: August 17, 2022

FROM: Jim Monreal, Assistant Superintendent, Business Services

THROUGH: Kris Munro, Superintendent

RECOMMENDATION:

Approve Monterey Peninsula Engineering change order #1 for maintenance facility yard repaving.

BACKGROUND:

This change order consists of removal of native soil and replacement with base rock, as there was no existing based rock under the existing paved area. The previously approved contract amount was \$448,000.00 and the new total contract, including this change order, will be \$506,342.00.

FISCAL IMPACT:

Change Order #1 \$58,342.00 (13.02% increase to the contract)

Cost Breakdown by fund:

\$37,922.30 Measure A District Set-Aside (Restricted)

\$20,419.70 Elementary Redevelopment Agency Fund (Restricted)

This work is in direct support of the following District goals and their corresponding metrics:

Goal #2: SCCS will create positive, engaging school environments that promote the development of cognitive skills and the social emotional well-being of all students.

Goal #5: SCCS will maintain a balanced budget and efficient and effective management.

Goal #6: SCCS will maintain strong communication and partnership with its diverse community.

Prepared by Trevor Miller, Director, Facility Services

AGENDA ITEM: 8.3.18.

Change Order

PROJECT: <i>(name and address)</i> SCCS Maint. Fac. Yard Repaving 536 Palm St. Santa Cruz, CA	CONTRACT INFORMATION: Contract For: SCCS Maint. Facility Yard Date: 04/18/22	CHANGE ORDER INFORMATION: Change Order Number: 001 Date: 08/01/22
OWNER: <i>(name and address)</i> Santa Cruz City Schools 133 Mission St. Suite #100 Santa Cruz, CA 95060	ARCHITECT: <i>(name and address)</i> Belli Architectural Group 235 Monterey St. Suite B Salinas	CONTRACTOR: <i>(name and address)</i> Monterey Peninsula Engineering 192 Healy Ave. Marina, CA 93933

THE CONTRACT IS CHANGED AS FOLLOWS:

(Insert a detailed description of the change and, if applicable, attach or reference specific exhibits. Also include agreed upon adjustments attributable to executed Construction Change Directives.)

See attached.

The original Contract Sum	was	\$	<u>448,000</u>
The net change by previously authorized Change Orders		\$	<u>0</u>
The Contract Sum	prior to this Change Order was	\$	<u>448,000</u>
The Contract Sum	will be increased by this Change Order in the amount of	\$	<u>58,342</u>
The new Contract Sum	, including this Change Order, will be	\$	<u>506,342</u>
The Contract Time will be increased by	zero (0) days.		
The new date of Substantial Completion will be N/A			

NOTE: This Change Order does not include adjustments to the Contract Sum or Guaranteed Maximum Price, or the Contract Time, that have been authorized by Construction Change Directive until the cost and time have been agreed upon by both the Owner and Contractor, in which case a Change Order is executed to supersede the Construction Change Directive.

NOT VALID UNTIL SIGNED BY THE ARCHITECT, CONTRACTOR AND OWNER.

Belli Architectural Group
 ARCHITECT *(Firm name)*

 SIGNATURE

David Noel Peartree, President
 PRINTED NAME AND TITLE

8/1/2022
 DATE

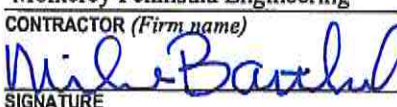
Monterey Peninsula Engineering
 CONTRACTOR *(Firm name)*

 SIGNATURE

MIKE BARTTEL
 PRINTED NAME AND TITLE

8-1-22
 DATE

Santa Cruz City Schools
 OWNER *(Firm name)*
 SIGNATURE

PRINTED NAME AND TITLE

DATE



MONTEREY PENINSULA ENGINEERING

CONTRACTORS & ENGINEERS
P.O. BOX 2317
MONTEREY, CA 93942
(831) 384-4081

May 26, 2022

Santa Cruz City Schools
536 Palm St.
Santa Cruz, Ca. 95060

Re: SCCS Maintenance Yard Paving / Request for Change

Add for lights and solar canopy per attached subcontractor RFC

For the amount of: <\$498.00>

Please review the above cost proposal and issue a change order for this work. I would also like to request a zero (0) working day extension to the contract completion date based on additional work and procurement time for inlet tops. Please contact me at (831) 384-4081 if you have any questions regarding this matter.

Please contact me at (831) 384-4081 if you have any questions regarding this matter.

Respectfully,

Mike Barthel
Project Manager



Darrel Varni Electric, Inc.

12 Parkwood Drive
Watsonville, Ca 95076
Lic #735622
www.dve-inc.com

Office: 831-761-2288 Fax:831-761-2285

Change Order

C/O Date: 5/24/2022

Quoted to: Monterey Peninsula Engineering
192 Healy Ave.

Marina, CA 93933

Regarding Job: SCCS Maintenance Yard
SCCS Maintenance Yard
536 Palm St.
Santa Cruz, CA

C/O Number:	1	Comments
Sequence:	0	
Owner C/O No:		

Description	Amount
Original Lighting Package as per plans/Specs	-16,507.00
New Gardco Lighting Package as per Santa Cruz City Schools	13,049.00
Delete Light Pole Foundation	-1,250.00
Provide additional conduit and boxes for future solar canopy	4,210.00

Original Contract	\$	75,880.00
Previous Change Orders	\$	0.00
Current Change Order	\$	-498.00
New Contract Total	\$	75,382.00

Authorized by: _____
Monterey Peninsula Engineering

Date: _____

Representative: _____

Date: _____

conner@mpe2000.com

From: conner@mpe2000.com
Sent: Thursday, May 12, 2022 11:43 AM
To: 'cgarcia@sccs.net'
Cc: Mike Barthel
Subject: SCCS Maintenance - Additional Tree Removal

Good afternoon Christopher,

Per our conversation today, 5/12/22, we can remove the additional tree at the SCCS Maintenance Facility Paving Project for a Lump Sum price of \$2600.

Sincerely,



Conner Schivo
Monterey Peninsula Engineering
Office 831-384-4081
Mobile 831-277-0137
Web www.montereypeninsulaengineering.com
Email conner@mpe2000.com
192 Healy Avenue, Marina CA, 93933



MONTEREY PENINSULA ENGINEERING

CONTRACTORS & ENGINEERS
P.O. BOX 2317
MONTEREY, CA 93942
(831) 384-4081

June 28, 2022

Santa Cruz City Schools
536 Palm St.
Santa Cruz, Ca. 95060

Re: SCCS Maintenance Yard Paving / Request for Change

Add for additional work to remove 8" of native material and replace with 8" of class 2 base rock – 10100 sf per attached extra work reports

For the amount of: \$56,240.00

Please review the above cost proposal and issue a change order for this work. I would also like to request a three (3) working day extension to the contract completion date based on additional work and procurement time for inlet tops. Please contact me at (831) 384-4081 if you have any questions regarding this matter.

Please contact me at (831) 384-4081 if you have any questions regarding this matter.

Respectfully,

Mike Barthel
Project Manager



Monterey Peninsula Engineering

P.O. Box 400
Marina, CA 93933
Ph: 831 384-4081
Fax: 831 883-1372

T&M RECAP

Date: 06/02/22
MPE #: 2212
LOG #: 12958

Bill To:

SANTA CRUZ CITY SCHOOLS
536 PALM STREET
SANTA CRUZ, CA

Copy To:

rev 6/28/22

Item	E#	Date	Job Location	Description	Quantity	Rate	Amount
1	21-862	5/16/22	SANTA CRUZ CITY SCHOOL	ADD ON 2 EXTRA DOWNSPOUTS TIE THEM INTO NEW 8" SDR STORM DRAIN PIPE	1.00	\$ 4,981.63	\$ 4,981.63
2	21-863	5/18/22	SANTA CRUZ CITY SCHOOL	SUBGRADE, LOAD OUT DIRT HAUL IN BASEROCK	1.00	\$ 10,536.88	\$ 10,536.88
3	21-864	5/19/22	SANTA CRUZ CITY SCHOOL	EXCAVATE 8" NATIVE DIRT TO MAKE SUBGRADE, LOAD OUT DIRT, HAUL IN	1.00	\$ 17,900.90	\$ 17,900.90
4	21-865	5/20/22	SANTA CRUZ CITY SCHOOL	RELOCATE NEW CATCH BASIN, RE-DIG TRENCH TO INSTALL 8" STORM DRAIN	1.00	\$ 5,116.35	\$ 5,116.35
5	21-897	6/1/22	SANTA CRUZ CITY SCHOOL	BASEROCK FINISH GRADE	1.00	\$ 7,928.79	\$ 7,928.79
6	21-898	6/2/22	SANTA CRUZ CITY SCHOOL	BASEROCK FINISH GRADE	1.00	\$ 6,122.51	\$ 6,122.51
7	21-899	6/3/22	SANTA CRUZ CITY SCHOOL	BASEROCK FINISH GRADE	1.00	\$ 3,653.90	\$ 3,653.90
						Total:	\$ 56,240.95

PACE Supply Corp
P.O. Box 6407
Rohnert Park, CA 94927-6407



INVOICE

INVOICE DATE	INVOICE #
05/19/22	167717783-1

PAGE
1 of 1

DATE SHIPPED	CUSTOMER #
05/19/22	39979-00

Branch Contact: 408-861-4100 FAX: 408-861-4346
Accounting & Credit: 855-306-5689



730 1 MB 0.485 ED236 I0408 D9130549807 S2 P9033413 0002:0003

SHIP TO



MONTEREY PENINSULA ENGINEERING
PO BOX 400
MARINA CA 93933-0400

MONTEREY PENINSULA ENGINEERING
536 PALM STREET
SANTA CRUZ, CA 95060

2212 9091 *RS*

CUSTOMER PURCHASE ORDER	JOB NAME	SHIPPED VIA	TERMS			TAXABLE
SC CITY SHOOL	SC CITY SCHOOLS	OUR TRUCK	2% 25TH NET 30TH			ITEMS
PART/DESCRIPTION		ORDER	SHIP	LIST	MULT	EXTENSION
NS00833847 Z191-24-CA DOWNSPOUT W/ CLEANOUT Vend Part#:		2	1	1039.83	NET	1039.83
PHWGY84 8 X 4 SDR26 WYE GASKETED		1	1	436.48	0.2399	104.75
PVPSDR268 8X14 PVC SDR26 SEWER PIPE		14	14	1601.00	NET	<i>OK</i> 224.14
PVPSCH403 3 X 20 BE PVC SCH40 PIPE		20	20	547.11	NET	109.42
PHWGRC8 8 SDR26 REPAIR COUPLING GASKETED		1	1	380.42	0.2352	89.50
PFFC4 4 PVC 40 SOC COUPLING 429-040		1	1	24.07	0.3600	8.67
PFFB43 4*3 PVC 40 SPGXSOC BUSHING 437-422		1	1	31.82	0.3600	11.46
PSFDWVSA4 4 SDR35 SOLV WELD HUB X DWV SOLV WELD SPIGOT ADAPTER Δ WARNING: The products you have purchased can expose you to chemicals and/or substances, which are known to the State of California to cause cancer and birth defects or other reproductive harm. For more information, go to www.P65Warnings.ca.gov		1	1	25.07	0.2500	6.27

Remit to: PACE Supply Corp P.O. Box 6407 Rohnert Park, CA 94927-6407
PLEASE BE AWARE IN AN EFFORT TO PROTECT OUR CUSTOMERS AND EMPLOYEES FROM COVID-19, PACE SUPPLY IS NOT CURRENTLY COLLECTING SIGNATURES ON ANY SALES ORDERS,

THIS INVOICE IS SUBJECT TO ALL TERMS AND CONDITIONS ON THE FACE AND REVERSE	GROSS 1594.04	TAX% 9.000	SALES TAX 147.96	SHIPPING & HANDLING 49.98	OTHER CHARGES 0.00	INVOICE TOTAL 1791.98
TO VIEW ONLINE GO TO: https://pacesupply.billtrust.com		USE THIS ENROLLMENT TOKEN: KWG QSM BMZ		BILLTRUST ACCOUNT #		39979

A discount amount of 35.84 is offered if your payment via check, ACH or cash is received by 06/25/2022.

Material Signed for by: Victor Vargas 05/19/22

2212 9891
TJM

S		PAGE # : 2	
H	PACE SUPPLY - SAN JOSE	ORDER # : 167717783-1	SHIP VIA : OUR TRUCK
I	630 QUINN AVE	ORD DATE: 05/12/22	FRT TERMS: BEST WAY
P	SAN JOSE, CA. 95112	REQ DATE: 05/19/22	CUST PO# : SC CITY SHOOL
P	TEL: 408-861-4100	ORD TYPE: UTILITY	W/BY : MAX YATES
E	FAX: 408-861-4346	P/TIME : 03:04PM	TERMS : 2% 25TH NET 3
R		P/DATE : 05/18/22	JOB NAME : SC CITY SCHOO
			ORDERED BY: DOMINGO

B		S	PHONE# 831-384-4081
I	39979-00	H	39979-00
L	MONTEREY PENINSULA ENGINEERING	I	MONTEREY PENINSULA ENGINEERING
L		P	536 PALM STREET
	P O BOX 400		SANTA CRUZ, CA 95060
T	MARINA, CA 93933	T	
O		O	

LN#	Q-SHP	Q-ORD	PART NUMBER / DESCRIPTION	LOCATION.....	UM	PRICE....	EXTENDED
1	1	2	NS00833847 Z191-24-CA DOWNSPOUT W/ CLEANOUT Vend Part#:		EA		
2	1	1	PHWGY84 8 X 4 SDR26 WYE GASKETED	02-13-02-A-2	EA		
3	14	14	PVPSDR268 8X14 PVC SDR26 SEWER PIPE PIPEWELL	09-09-03	CF		
4	20	20	PVPSCH403 3 X 20 BE PVC SCH40 PIPE	07-08-10-B	CF		
5	1	1	PHWGRC8 8 SDR26 REPAIR COUPLING GASKETED	02-13-04-B-3	EA		
6	1	1	PFFC4 4 PVC 40 SOC COUPLING 429-040	01-31-15-B-1	EA		
7	1	1	PFFB43 4*3 PVC 40 SPGXSOC BUSHING 437-422	01-31-16-B-2	EA		
8	1	1	PSFDWVSA4 4 SDR35 SOLV WELD HUB X DWV SOLV WELD SPIGOT	02-13-16-D-1	EA		

2bx 215
2 pcc pipe

PACE Supply Corp
P.O. Box 6407
Rohnert Park, CA 94927-6407



INVOICE

INVOICE DATE	INVOICE #	PAGE 1 of 1
05/25/22	167717783-2	

DATE SHIPPED	CUSTOMER #
05/24/22	39979-00

Branch Contact: 408-861-4100 FAX: 408-861-4346
Accounting & Credit: 855-306-5689

1105 1 AB 0.461 E0015X 10016 D9152748116 S2 P9044498 0001:0001

SHIP TO



MONTEREY PENINSULA ENGINEERING
PO BOX 400
MARINA CA 93933-0400

MONTEREY PENINSULA ENGINEERING
536 PALM STREET
SANTA CRUZ, CA 95060

2212 9091 RJ

CUSTOMER PURCHASE ORDER SC CITY SHOOL	JOB NAME SC CITY SCHOOLS	SHIPPED VIA OUR TRUCK	TERMS 2% 25TH NET 30TH	TAXABLE ITEMS
--	-----------------------------	--------------------------	---------------------------	------------------

PART/DESCRIPTION	ORDER	SHIP	LIST	MULT	EXTENSION	
NS00833847 Z191-24-CA DOWNSPOUT W/ CLEANOUT Vend Part#:	1	1	1039.83	NET	1039.83	Y
MIS5644ARC 4 CI/PL*CI/PL COUPLING W/SR MISSION Δ WARNING: The products you have purchased can expose you to chemicals and/or substances, which are known to the State of California to cause cancer and birth defects or other reproductive harm. For more information, go to www.P65Warnings.ca.gov	1	1	42.53	NET	42.53	Y

Remit to: PACE Supply Corp P.O. Box 6407 Rohnert Park, CA 94927-6407
PLEASE BE AWARE IN AN EFFORT TO PROTECT OUR CUSTOMERS
AND EMPLOYEES FROM COVID-19, PACE SUPPLY IS NOT
CURRENTLY COLLECTING SIGNATURES ON ANY SALES ORDERS,

RECEIVED
JUN 01 2022

BY:

THIS INVOICE IS SUBJECT TO ALL TERMS AND CONDITIONS ON THE FACE AND REVERSE	GROSS 1082.36	TAX% 9.000	SALES TAX 97.41	SHIPPING & HANDLING 0.00	OTHER CHARGES 0.00	INVOICE TOTAL 1179.77
---	------------------	---------------	--------------------	-----------------------------	-----------------------	--------------------------

TO VIEW ONLINE GO TO: <https://pacesupply.billtrust.com> USE THIS ENROLLMENT TOKEN: **KWG QSM BMZ** BILLTRUST ACCOUNT # 39979

A discount amount of 23.60 is offered if your payment via check, ACH or cash is received by 06/25/2022.

Material Signed for by: Don 06/24/22

2212 9091
Tomy

S		PAGE # : 2	**DUPLICATE**
H	PACE SUPPLY - SAN JOSE	ORDER # : 167717783-2	SHIP VIA : OUR TRUCK
I	630 QUINN AVE	ORD DATE: 05/12/22	FRT TERMS: BEST WAY
P	SAN JOSE, CA. 95112	REQ DATE: 05/24/22	CUST PO# : SC CITY SHOOL
P	TEL: 408-861-4100	ORD TYPE: UTILITY	W/BY : MAX YATES
E	FAX: 408-861-4346	P/TIME : 09:53AM	TERMS : 2% 25TH NET 3
R		P/DATE : 05/24/22	JOB NAME : SC CITY SCHOOL
			ORDERED BY: DOMINGO

B		S	PHONE# 831-384-4081
I	39979-00	H	39979-00
L	MONTEREY PENINSULA ENGINEERING	I	MONTEREY PENINSULA ENGINEERING
L		P	536 PALM STREET
	P O BOX 400		SANTA CRUZ, CA 95060
T	MARINA, CA 93933	T	
O		O	

LN#	Q-SHP	Q-ORD	PART NUMBER / DESCRIPTION	LOCATION.....	UM	PRICE....	EXTENDED
2	1	1	NS00833847 Z191-24-CA DOWNSPOUT W/ CLEANOUT Vend Part#:		EA	✓	
2	1	1	MIS5644ARC 4 CI/PL*CI/PL COUPLING W/SR MISSION	01-08-08-D-1	EA	✓	

** ***** PACE SUPPLY IS PROUD TO ANNOUNCE THAT WE ARE NOW OPEN TO
 ** SERVE OUR CUSTOMERS IN MEDFORD, OREGON *****
 ** IN ORDER TO PROTECT OUR CUSTOMERS FROM COVID 19, WE MAY NOT BE AB
 ** LE TO CAPTURE SIGNATURES AT EVERY COUNTER, DUE TO PARTITIONS.
 ** ***
 ** PLEASE BE AWARE THAT IN AN EFFORT TO PROTECT OUR
 ** CUSTOMERS AND EMPLOYEES FROM COVID-19, PACE SUPPLY IS NOT
 ** CURRENTLY COLLECTING SIGNATURES ON ANY SALES ORDERS.

CK: BOAL

\$SHIP&HANDLING: _____ SHIPPER#: _____ CARTON QTY: _____
 WEIGHT : _____ SHP DATE: _____ PULLED BY: Johnny

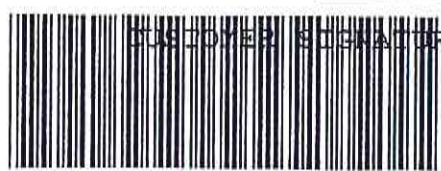

CUSTOMER SIGNATURE: _____
 CUSTOMER NAME (PRINT) : _____

Job#: 2212
 Date Performed: 5/18/2022
 E#: 21-863
 LOG#: 12958

DAILY EXTRA WORK REPORT
 MONTEREY PENINSULA ENGINEERING, LIC# 972425

Work Performed by:

Description of Work: EXCAVATE 8" OF NATIVE DIRT TO MAKE SUBGRADE, LOAD OUT DIRT AND HAUL IN BASEROCK

EQUIP. NO.	EQUIPMENT	OT/Delay Factor	HOURS		HOURLY RATE	EXTENDED AMOUNTS	LABOR		HOURS	HOURLY RATE	EXTENDED AMOUNTS
			RT	OT			RT	OT			
3554	JD 225D LC EXCAVATOR	1	8		\$ 125.00	\$ 1,000.00	FOREPERSON	8	\$ 120.00	\$ 960.00	
3519	CASE 590SN 4WD B/H	1	8		\$ 70.00	\$ 560.00	DOMINGO NAZARIO	8	\$ 81.61	\$ 652.88	
0		1					OPERATOR 4				
		1					GERARDO GAYTAN				
0		1					OPERATOR 4	8	\$ 81.61	\$ 652.88	
		1					MARCO GALICIA				
0		1					OPERATOR 2	8	\$ 84.47	\$ 675.76	
		1					JEFF THURINGER				
0		1					LABOR 1	8	\$ 59.69	\$ 477.52	
		1					PABLO ESTRADA				
0		1					0	0	\$ -	\$ -	
		1					0	0	\$ -	\$ -	
0		1					0	0	\$ -	\$ -	
		1					0	0	\$ -	\$ -	
0		1					0	0	\$ -	\$ -	
		1					0	0	\$ -	\$ -	
0		1					0	0	\$ -	\$ -	
		1					0	0	\$ -	\$ -	
0		1					0	0	\$ -	\$ -	
		1					0	0	\$ -	\$ -	
0		1					0	0	\$ -	\$ -	
		1					0	0	\$ -	\$ -	
0		1					0	0	\$ -	\$ -	
		1					0	0	\$ -	\$ -	
0		1					0	0	\$ -	\$ -	
		1					0	0	\$ -	\$ -	
MATERIAL and/or WORK DONE BY SPECIALISTS											
Description	No. Units	Unit Cost	Amount								
6819 ERS	8.50	\$130.00	\$1,105.00								
6882 ERS	7.75	\$130.00	\$1,007.50								
90760 SUNSET PACIFIC	7.50	\$130.00	\$975.00								
BASEROCK 1 LOAD	14.00	\$15.00	\$210.00								
	1.00	\$0.00	\$0.00								
	1.00	\$0.00	\$0.00								
	FUEL SURCHARGE	\$1,560.00	2% OF EQUIP FEE								
TOTAL COST OF EQUIPMENT, MATERIALS AND WORK											
15% MARK-UP ON LABOR COST											
15% MARK-UP ON EQUIP., MATERIAL AND WORK COST											
TOTAL THIS REPORT											
										\$	4,273.80
										\$	4,888.70
										\$	641.07
										\$	733.31
										\$	10,536.88

465/713

2878

DATE 5/18/22	MATERIAL DIRT	TYPE OF LOADING	<input type="checkbox"/> BELT <input type="checkbox"/> BUNKER	<input type="checkbox"/> HOT PLANT <input checked="" type="checkbox"/> FRONT LOADER	<input type="checkbox"/> OTHER	
DESTINATION: WHERE MAT'L DELIVERED	JENSON RD MOSS LAWNES		JOB NO = 2212	TAG NO. 6819		
POINT OF ORIGIN: WHERE MAT'L WAS ORDERED	SCCS SANTA CRUZ			EQUIP. NO. 03		
CONSIGNOR: WHO OWNED MAT'L	MPE		CONSIGNOR ADDRESS			
CONSIGNEE: WHO REC'D MAT'L	MPE		CONSIGNEE ADDRESS			
DEBTOR: WHO PAYS LBS			DEBTOR ADDRESS			
LOCATION DRIVER REPORTED	NO. AXLES	MILEAGE	WHEN ZONE RATES APPLY PROD. AREA:	DEL. ZONE:	YARD CAPY CY	
ORIGIN	MATERIAL	LOADING		DESTINATION	UNLOADING	
		ARRIVE	DEPART		ARRIVE	DEPART
1 SANTA CRUZ	DIRT	8:00am	8:20am	JENSON	9:00am	9:10am
2 SANTA CRUZ	DIRT	9:40am	9:45am	JENSON	10:15am	10:25am
3 SANTA CRUZ	DIRT	10:50am	11:00am	JENSON	11:30am	11:35am
4 SANTA CRUZ	DIRT	12:00pm	1:00pm	JENSON	1:40pm	1:45pm
5 SANTA CRUZ	DIRT	2:15pm	2:30pm	JENSON	3:20pm	3:30pm
6						
7	1 HOUR BACK TO SCCS					
8						
9						
10						
11						
12						
13						
14						
15						
REMARKS	DRIVER REPORTING TIME	FUEL		COMPUTATION OF HOURLY SERVICE FREIGHT BILL		
	SUBTRACT STARTING TIME OF LAST TRIP	= BASE HOURS →				
	ENDING TIME OF LAST TRIP	ELAPSED TIME OF THE RUNNING TIME OF LAST TRIP *2 =				
STARTING TIME OF UNLOADING OF LAST TRIP	ENDING TIME OF UNLOADING TIME OF LAST TRIP	ELAPSED TIME OF THE UNLOADING TIME OF LAST TRIP				
8:00	4:30	8.50				
DRIVER'S SIGNATURE BY UNDERLYING CARRIER	I agree court costs, 33 1/3% attorney fees, and all costs that arise from any proceedings for the collection of amounts due to the above carrier for work done for the above shipper will be paid by the above shipper. NOT RESPONSIBLE FOR BROKEN SIDEWALKS, CURBS OR OTHER PROPERTY WHEN DELIVERY IS REQUESTED ON PREMISES.		OVERALL TIME FROM TIME REPORTING FOR WORK TO START OF LAST TRIP PLUS DOUBLE RUNNING TIME OF LAST TRIP PLUS UNLOADING TIME OF LAST TRIP			
ADDRESS	NET CHARGEABLE TIME OR TONS		SUBTRACT DEDUCTIBLE TIME			
BY Tom...	MULTIPLY BY TONAGE OR HOURLY RATE		X \$			
	RECEIVED IN GOOD ORDER BY FOREMAN		TOTAL DUE →			

P.U.C. REQUIRES PAYMENTS FOR THESE CHARGES NOT LATER THAN THE 15TH OF THE FOLLOWING MONTH.

EQUIPMENT REPAIR SERVICE ERS

140 Peatree Lane, Hollister, CA 95023 · (831) 537-5106 CA #492201

DATE 7/1/12	MATERIAL DIRT	TYPE OF LOADING	<input type="checkbox"/> BELT	<input type="checkbox"/> HOT PLANT	<input type="checkbox"/> OTHER		
			<input type="checkbox"/> BUNKER	<input checked="" type="checkbox"/> FRONT LOADER			
DESTINATION: WHERE MAT'L DELIVERED TENTON RD HOLLISTER CA 95023		JOB NO. # 2212	TAG NO. 6819				
POINT OF ORIGIN: WHERE MAT'L WAS ORDERED MIFA		EQUIP. NO. 03					
CONSIGNOR: WHO OWNED MAT'L MIFE		CONSIGNOR ADDRESS					
CONSIGNEE: WHO REC'D MAT'L MIFE		CONSIGNEE ADDRESS					
DEBTOR: WHO PAYS LBS		DEBTOR ADDRESS					
LOCATION DRIVER REPORTED	NO. AXLES	MILEAGE	WHEN ZONE RATES APPLY PROD. AREA: DEL. ZONE:		YARD CAPY CY		
ORIGIN	MATERIAL	LOADING		DESTINATION	UNLOADING		
		ARRIVE	DEPART		ARRIVE	DEPART	
1 TANTA CRUE	DIRT	8:00am	8:30am	JERSON	9:00am	9:15am	
2 TANTA CRUE	DIRT	7:45am	9:00am	JERSON	10:15am	10:25am	
3 TA TA CZ	DIRT	10:30am	11:00am	JERSON	11:30am	11:35am	
4 MIFA CZ	DIRT	12:15pm	1:00pm	JERSON	1:40pm	1:45pm	
5 TANTA CRUE	DIRT	2:15pm		JERSON			
6							
7							
8							
9							
10							
11							
12							
13							
14							
15							
REMARKS / / /		DRIVER REPORTING TIME	FUEL		COMPUTATION OF HOURLY SERVICE FREIGHT BILL		
		SUBTRACT STARTING TIME OF LAST TRIP		= BASE HOURS →			
		ENDING TIME OF LAST TRIP	ELAPSED TIME OF THE RUNNING TIME OF LAST TRIP		X 2 =		
STARTING TIME OF UNLOADING OF LAST TRIP		ENDING TIME OF UNLOADING TIME OF LAST TRIP		ELAPSED TIME OF THE UNLOADING TIME OF LAST TRIP			
DRIVER'S SIGNATURE BY _____		Rec'd by carrier in good condition as noted		OVERALL TIME FROM TIME REPORTING FOR WORK TO START OF LAST TRIP PLUS DOUBLE RUNNING TIME OF LAST TRIP PLUS UNLOADING TIME OF LAST TRIP			
UNDERLYING CARRIER _____				SUBTRACT DEDUCTIBLE TIME			
ADDRESS _____				NET CHARGEABLE TIME OR TONS			
I agree court costs, 33 1/3% attorney fees, and all costs that arise from any proceedings for the collection of amounts due to the above carrier for work done for the above shipper will be paid by the above shipper. NOT RESPONSIBLE FOR BROKEN SIDEWALKS, CURBS OR OTHER PROPERTY WHEN DELIVERY IS REQUESTED ON PREMISES.				MULTIPLY BY TONAGE OR HOURLY RATE X \$			
BY _____		RECEIVED IN GOOD ORDER BY FOREMAN		TOTAL DUE →			

P.U.C. REQUIRES PAYMENTS FOR THESE CHARGES NOT LATER THAN THE 15TH OF THE FOLLOWING MONTH.

EQUIPMENT REPAIR SERVICE ERS

140 Peatree Lane, Hollister, CA 95023 · (831) 537-5106 CA #492201

DATE 5-18-22		MATERIAL	TYPE OF LOADING	<input type="checkbox"/> BELT	<input type="checkbox"/> HOT PLANT	<input type="checkbox"/> OTHER
				<input type="checkbox"/> BUNKER	<input type="checkbox"/> FRONT LOADER	
DESTINATION: WHERE MAT'L DELIVERED			JOB NO 2212 TAG NO. 6882			
POINT OF ORIGIN: WHERE MAT'L WAS ORDERED			EQUIP. NO.			
CONSIGNOR: WHO OWNED MAT'L			CONSIGNOR ADDRESS			
CONSIGNEE: WHO RECD MAT'L			CONSIGNEE ADDRESS			
DEBTOR: WHO PAYS LBS			DEBTOR ADDRESS			
LOCATION DRIVER REPORTED	NO. AXLES	MILEAGE	WHEN ZONE RATES APPLY: PROD. AREA: DEL. ZONE:		YARD CAP'Y CY	
ORIGIN	MATERIAL	LOADING		DESTINATION	UNLOADING	
		ARRIVE	DEPART		ARRIVE	DEPART
1. 2212	DIRT	7:45	8:00	JANSON	8:30	8:45
2. 2212	DIRT	9:15	9:30	JANSON	10:00	10:15
3. 2212	DIRT	10:45	11:00	JANSON	11:30	11:45
4. 2212	DIRT	12:45	12:50	JANSON	1:00	1:15
5. 2212	DIRT	1:45		JANSON		
6.						
7.						
8.						
9.						
10.						
11.						
12.						
13.						
14.						
15.						
REMARKS:		DRIVER REPORTING TIME		FUEL		COMPUTATION OF HOURLY SERVICE FREIGHT BILL
		SUBTRACT STARTING TIME OF LAST TRIP		= BASE HOURS →		
		ENDING TIME OF LAST TRIP		ELAPSED TIME OF THE RUNNING TIME OF LAST TRIP X 2 =		
STARTING TIME OF UNLOADING OF LAST TRIP		ENDING TIME OF UNLOADING TIME OF LAST TRIP		ELAPSED TIME OF THE UNLOADING TIME OF LAST TRIP		
DRIVER'S SIGNATURE BY <u>Hedrick</u>		Rec'd by carrier in good condition as noted		OVERALL TIME FROM TIME REPORTING FOR WORK TO START OF LAST TRIP PLUS DOUBLE RUNNING TIME OF LAST TRIP PLUS UNLOADING TIME OF LAST TRIP		
UNDERLYING CARRIER:				SUBTRACT DEDUCTIBLE TIME		
ADDRESS:				NET CHARGEABLE TIME OR TONS		
I agree court costs, 133/3% attorney fees, and all costs that arise from any proceedings for the collection of amounts due to the above carrier for work done for the above shipper will be paid by the above shipper. NOT RESPONSIBLE FOR BROKEN SIDEWALKS, CURBS OR OTHER PROPERTY WHEN DELIVERY IS REQUESTED ON PREMISES.		RECEIVED IN GOOD ORDER BY FOREMAN		MULTIPLY BY TONNAGE OR HOURLY RATE X \$		
				TOTAL DUE →		

745 -
230
+1
73/4

P.U.C. REQUIRES PAYMENTS FOR THESE CHARGES NOT LATER THAN THE 15TH OF THE FOLLOWING MONTH.

SUNSET PACIFIC CONSTRUCTION CO., INC.

192 Healy Avenue., Marina, CA 93933 • (831) 384-4115

PUC#T-151856

DATE: 5-18-22 MATERIAL: _____ TYPE OF: BELT HOT PLANT OTHER
 LOADING: BUNKER FRONT LOADER

DESTINATION: WHERE MAT'L DELIVERED Santa Cruz 2222 TAG NO. 90760
 POINT OF ORIGIN: WHERE MAT'L WAS ORDERED Jensen Rd - 1st 3rd EQUIP. NO. 2403

CONSIGNOR: WHO OWNED MAT'L MPE CONSIGNOR ADDRESS _____
 CONSIGNEE: WHO REC'D MAT'L MPE CONSIGNEE ADDRESS _____
 DEBTOR: WHO PAYS LBS. _____ DEBTOR ADDRESS _____

1 LOAD

TAG NUMBER	WEIGHT	LOADING		LEAVE SCALES	UNLOADING	
		ARRIVE	DEPART		ARRIVE	DEPART
1	Dirt	7:25	8:05		8:40	8:45
2	Dirt	9:25	9:30		10:05	10:10
3	Dirt Concrete	10:40	10:50		11:45	11:55
4	Base Rock Dirt	1:00	1:15		1:45	1:50
5	Dirt	2:30	2:35			
6						
7						
8						
9						
10						
11						
12						
13						
14						
15						

7 hrs

+ 1/2

7 1/2

REMARKS: 1 1/2 load

DRIVER REPORTING TIME: 6:15 FUEL: _____ COMPUTATION OF HOURLY SERVICE FREIGHT BILL

SUBTRACT STARTING TIME OF LAST TRIP = BASE HOURS →

ENDING TIME OF LAST TRIP ELAPSED TIME OF THE RUNNING TIME OF LAST TRIP X 2 =

STARTING TIME OF UNLOADING OF LAST TRIP ENDING TIME OF UNLOADING TIME OF LAST TRIP ELAPSED TIME OF THE UNLOADING TIME OF LAST TRIP

DRIVER'S SIGNATURE BY: Enrique Lopez Rec'd by carrier in good condition as noted. OVERALL TIME FROM TIME REPORTING FOR WORK TO START OF LAST TRIP PLUS DOUBLE RUNNING TIME OF LAST TRIP PLUS UNLOADING TIME OF LAST TRIP

UNDERLYING CARRIER: _____ SUBTRACT DEDUCTIBLE TIME

ADDRESS: _____ NET CHARGEABLE TIME OR TONS

I agree court costs, 33 1/3% attorney fees, and all costs that arise from any proceedings for the collection of amounts due to the above carrier for work done for the above shipper will be paid by the above shipper. NOT RESPONSIBLE FOR BROKEN SIDEWALKS, CURBS OR OTHER PROPERTY WHEN DELIVERY IS REQUESTED ON PREMISES. MULTIPLY BY TONAGE OR HOURLY RATE X \$ _____

BY: [Signature] RECEIVED IN GOOD ORDER BY FOREMAN TOTAL DUE → _____

P.U.C. REQUIRES PAYMENTS FOR THESE CHARGES NOT LATER THAN THE 15TH OF THE FOLLOWING MONTH.

WHITE - REV. ACCT. YELLOW - OFFICE PINK - DELIVERY GOLD - SUB HAUL



12958

MONTEREY PENINSULA ENGINEERING

DAILY EXTRA WORK REPORT

BILLING INFORMATION:
NAME: SecS Maintenance Facility
ADDRESS:
CITY/STATE/ZIP:
PHONE:

DATE PERFORMED 5-19-22

WORK PERFORMED AT THE DIRECTION OF: SecS Maintenance Facility

CONTRACTOR JOB NO. 2212
CONTRACTOR REPORT NO. 2758064

DESCRIPTION OF WORK: Excavate 8" of native dirt to make subgrade. load out dirt, haul in base rock, remove new installed 4" and 8" storm drain pipe.

EQUIPMENT			LABOR			HOURLY RATE	HOURS	EXTENDED AMOUNTS
EQUIP NO.	HOURS	HOURLY/DAILY RATE	P.R. NO.	LABOR	O.T.			
3554	8		F	Dominique Navarro III		8		
3579	8		63/104	Gerardo Gastan		8		
2434	8		04	Mario Galicia		8		
3544	8		02	Jeff Thuringer		8		
			41	Victor Vargas		8		
			07	Pablo Estrada		8		

MATERIAL AND/OR WORK DONE BY SPECIALISTS

DESCRIPTION	NO. UNIT	UNIT COST	EXTENDED	SUB-TOTAL
ERS - 6820				
ERS - 6883				
Sunset Pacific - 90761				
Sunset Pacific - 90786				
HASAMMO				
TOTAL COST OF LABOR				
				A
→				
TOTAL COST OF EQUIPMENT, MATERIALS AND WORK				B

TOTAL COST OF EQUIPMENT, MATERIALS AND WORK

Dominique Navarro
CONTRACTOR'S REPRESENTATIVE

TOTAL A & B

MARKUP ON EQUIPMENT, MATERIAL AND WORK COST _____%

ACCEPTED:

OWNER/AGENT



TOTAL THIS REPORT

EQUIPMENT REPAIR SERVICES

140 Peatree Lane, Hollister, CA 95023 - (831) 537-5106 CA #492201

S/O
14 TON PER
LOAD
3 LOADS

DATE 5/19/22	MATERIAL ROCK/DIRT	TYPE OF LOADING	<input type="checkbox"/> BELT <input type="checkbox"/> BUNKER	<input type="checkbox"/> HOT PLANT <input checked="" type="checkbox"/> FRONT LOADER	<input type="checkbox"/> OTHER
DESTINATION: WHERE MAT'L DELIVERED SCCS		JOB NO. 2012	TAG NO. 6820		
POINT OF ORIGIN: WHERE MAT'L WAS ORDERED 1/2 RD		EQUIP. NO. 03			
CONSIGNOR: WHO OWNED MAT'L AIFE		CONSIGNOR ADDRESS			
CONSIGNEE: WHO REC'D MAT'L AIFE		CONSIGNEE ADDRESS			
DEBTOR: WHO PAYS LBS		DEBTOR ADDRESS			

LOCATION DRIVER REPORTED	NO. AXLES	MILEAGE	WHEN ZONE RATES APPLY PROD. AREA DEL. ZONE	YARD CAPY
--------------------------	-----------	---------	---	-----------

ORIGIN	MATERIAL	LOADING		DESTINATION	UNLOADING	
		ARRIVE	DEPART		ARRIVE	DEPART
1/2 RD	B ROCK	6:40am	7:45am	SCCS	8:15am	8:45am
SCCS	DIRT	8:15am	8:45am	TELESON	8:50am	8:55am
1/2 RD	B ROCK	9:20am	9:50am	SCCS	10:30am	10:40am
SCCS	DIRT	10:30am	10:40am	TELESON	11:50am	11:55am
1/2 RD	B ROCK	11:50am	12:10pm	SCCS	1:05pm	
SCCS	DIRT			TELESON		
7						
8						
9						
10						
11						
12						
13						
14						
15						

640 -
1.40
+ 1/2 Hr
7 1/2

REMARKS	DRIVER REPORTING TIME	FUEL	COMPUTATION OF HOURLY SERVICE/FREIGHT BILL
	SUBTRACT STARTING TIME OF LAST TRIP		BASE HOURS
	ENDING TIME OF LAST TRIP	ELAPSED TIME OF THE RUNNING TIME OF LAST TRIP	X 2

STARTING TIME OF UNLOADING OF LAST TRIP	ENDING TIME OF UNLOADING TIME OF LAST TRIP	ELAPSED TIME OF THE UNLOADING TIME OF LAST TRIP
DRIVER'S SIGNATURE BY UNDERLYING CARRIER		OVERALL TIME FROM TIME REPORTING FOR WORK TO START OF LAST TRIP PLUS DOUBLE RUNNING TIME OF LAST TRIP PLUS UNLOADING TIME OF LAST TRIP
ADDRESS		SUBTRACT DEDUCTIBLE TIME
I agree our costs, 83 1/3% attorney fees, and all costs that arise from any proceedings for the collection of amounts due to the above carrier for work done for the above shipper will be paid by the above shipper. INDIAN RESPONSIBLE FOR BROKEN SIDE WALKS, CURBS OR OTHER PROPERTY WHEN DELIVERY IS REQUESTED ON PREMISES.		NET CHARGEABLE TIME OR TONS
BY		MULTIPLY BY TONNAGE OR HOURLY RATE
RECEIVED IN GOOD ORDER BY FOREMAN		TOTAL DUE

P.U.C. REQUIRES PAYMENTS FOR THESE CHARGES NOT LATER THAN THE 15TH OF THE FOLLOWING MONTH.

140 Peatree Lane, Hollister, CA 95023 · (831) 537-5106 CA #45

510
31040J

DATE 5-17-22	MATERIAL	TYPE OF LOADING	<input type="checkbox"/> BELT <input type="checkbox"/> BUNKER	<input type="checkbox"/> HOT PLANT <input type="checkbox"/> FRONT LOADER
DESTINATION: WHERE MAT'L DELIVERED		JOB NO. 2212	TAG NO. 6883	
POINT OF ORIGIN: WHERE MAT'L WAS ORDERED 1#3		EQUIP. NO.		
CONSIGNOR: WHO OWNED MAT'L		CONSIGNOR ADDRESS MPE		
CONSIGNEE: WHO REC'D MAT'L		CONSIGNEE ADDRESS Palmdale ST		
DEBTOR: WHO PAYS LBS		DEBTOR ADDRESS Santa Ana		
LOCATION DRIVER REPORTED	NO. AXLES	MILEAGE	WHEN ZONE RATES APPLY PROD. AREA: DEL. ZONE:	

ORIGIN	MATERIAL	LOADING		DESTINATION	UNLO ARRIVE
		ARRIVE	DEPART		
1#3	Rock	6:35	6:45	2212	7:45
2212	dist	7:45	8:00	Jensen	8:30
2212	dist	7:15	7:30	Jensen	10:00
1#3	Rock	10:45	10:50	2212	11:50
1#3	Rock	12:55		2212	
6					
7					
8					
9					
10					
11					
12					
13					
14					
15					

635
135
+ 1/2 hr
7 1/2

REMARKS	DRIVER REPORTING TIME	FUEL	COMPUT SERVICE
	SUBTRACT STARTING TIME OF LAST TRIP		= BASE HOURS →
	ENDING TIME OF LAST TRIP	ELAPSED TIME OF THE RUNNING TIME OF LAST TRIP	X 2 =
STARTING TIME OF UNLOADING OF LAST TRIP 6:35	ENDING TIME OF UNLOADING TIME OF LAST TRIP	ELAPSED TIME OF THE UNLOADING TIME OF LAST TRIP	
DRIVER'S SIGNATURE BY Rodolfo C	OVERALL TIME FROM TIME REPORTING FOR WORK TO START OF LAST TRIP PLUS DOUBLE RUNNING TIME OF LAST TRIP PLUS UNLOADING TIME OF LAST TRIP		
UNDERLYING CARRIER	SUBTRACT DEDUCTIBLE TIME		
ADDRESS	NET CHARGEABLE TIME OR TONS		
I agree court costs, 33 1/3% attorney fees, and all costs that arise from any proceedings for the collection of amounts due to the above carrier for work done for the above shipper will be paid by the above shipper. NOT RESPONSIBLE FOR BROKEN SIDEWALKS, CURBS OR OTHER PROPERTY WHEN DELIVERIES REQUESTED ON PREMISES.			
RECEIVED IN GOOD ORDER BY FOREMAN			
TOTAL DUE →			

P. U. C. REQUIRES PAYMENTS FOR THESE CHARGES NOT LATER THAN THE 15TH OF THE FOLLOWING MONTH.

SUNSET PACIFIC CONSTRUCTION CO., INC.

192 Healy Avenue, Marina, CA 93933 • (831) 384-4115

PUC # T-151856

DATE 5-19-22	MATERIAL	TYPE OF : <input type="checkbox"/> BELT LOADING : <input type="checkbox"/> BUNKER	<input type="checkbox"/> HOT PLANT <input type="checkbox"/> FRONT LOADER
DESTINATION: SANTA CRUZ		JOB NO. =	TAG NO. 90761
POINT OF ORIGIN: 1st 3rd Jensen Rd.		EQUIP. NO. 2403	
WHERE MAT'L WAS ORDERED			
CONSIGNOR: WHO OWNED MAT'L MPE	CONSIGNOR ADDRESS		
CONSIGNEE: WHO REC'D MAT'L MPE	CONSIGNEE ADDRESS		
DEBTOR:		DEBTOR ADDRESS	
WHO PAYS LBS.			

LOCATION DRIVER REPORTED	NO. AXLES	MILEAGE	WHEN ZONE RATES APPLY	YARD. CAPY
			PROD. AREA: DEL. ZONE:	CY

TAG NUMBER	WEIGHT	LOADING		LEAVE SCALES	UNLOADING	
		ARRIVE	DEPART		ARRIVE	DEPART
1 Base Rock		6:20	6:25		7:30	7:45
2 DIRT		8:15	8:20		8:50	8:55
3 Base Rock DIRT		10:00	10:30		11:00	11:05
4 Base Rock DIRT		11:35	11:40		12:30	1:00
5 DIRT		1:40	1:50		2:40	
6						
7						
8						
9						
10						
11						
12						
13						
14						
15						

S/O
SLOWOS

9 AM
+ 1/2
TRAVEL
9 1/2

REMARKS <i>1/2 Lunch</i>	DRIVER REPORTING TIME 5:45	FUEL: 82	COMPUTATION OF HOURLY SERVICE FREIGHT BILL
	SUBTRACT STARTING TIME OF LAST TRIP = BASE HOURS →		
	ENDING TIME OF LAST TRIP 2:45	ELAPSED TIME OF THE RUNNING TIME OF LAST TRIP x2 =	
	STARTING TIME OF UNLOADING OF LAST TRIP	ENDING TIME OF UNLOADING TIME OF LAST TRIP	ELAPSED TIME OF THE UNLOADING TIME OF LAST TRIP
DRIVER'S SIGNATURE BY <i>E. George S. de...</i>	OVERALL TIME FROM TIME REPORTING FOR WORK TO START OF LAST TRIP PLUS DOUBLE RUNNING TIME OF LAST TRIP PLUS UNLOADING TIME OF LAST TRIP		
UNDERLYING CARRIER	SUBTRACT DEDUCTIBLE TIME		
ADDRESS	NET CHARGEABLE TIME OR TONS		
I agree court costs, 33 1/3% attorney fees, and all costs that arise from any proceedings for the collection of amounts due to the above carrier for work done for the above shipper will be paid by the above shipper. NOT RESPONSIBLE FOR BROKEN SIDEWALKS, CURBS OR OTHER PROPERTY WHEN DELIVERY IS REQUESTED ON PREMISES.			MULTIPLY BY TONAGE OR HOURLY RATE x \$
BY _____	TOTAL DUE →		
RECEIVED IN GOOD ORDER BY FOREMAN			

P.U.C. REQUIRES PAYMENTS FOR THESE CHARGES NOT LATER THAN THE 15TH OF THE FOLLOWING MONTH.

WHITE - REV. ACCT. YELLOW - OFFICE PINK - DELIVERY GOLD - SUB HAUL

SUNSET PACIFIC CONSTRUCTION CO., INC.

192 Healy Avenue., Marina, CA 93933 • (831) 384-4115

PUC # T-151856

310
300005

DATE 5/19/22	MATERIAL Base Rock	TYPE OF • <input type="checkbox"/> BELT <input type="checkbox"/> HOT PLANT <input type="checkbox"/> OTHER LOADING • <input type="checkbox"/> BUNKER <input type="checkbox"/> FRONT LOADER
DESTINATION: WHERE MAT'L DELIVERED Palm St	JOB NO. = 2212	TAG NO. 90786
POINT OF ORIGIN: WHERE MAT'L WAS ORDERED MPE	EQUIP. NO. 2423	
CONSIGNOR: WHO OWNED MAT'L MPE	CONSIGNOR ADDRESS	
CONSIGNEE: WHO REC'D MAT'L MPE	CONSIGNEE ADDRESS	
DEBTOR: WHO PAYS LBS.	DEBTOR ADDRESS	

LOCATION DRIVER REPORTED Truck Yard	NO. AXLES	MILEAGE	WHEN ZONE RATES APPLY PROD. AREA: DEL. ZONE:	YARD. CAPY CY
---	-----------	---------	---	------------------

TAG NUMBER	WEIGHT	LOADING		LEAVE SCALES	UNLOADING	
		ARRIVE	DEPART		ARRIVE	DEPART
1 TRAVEL	6:30	Truck Yard to	143	---	6:45	
2 143 Base Rock	6:45	7:00		8:40	8:50	
3 Palm St DIRT	8:50	8:55		9:24	9:34	
4 143 Base Rock	10:00	10:15		11:05	11:17	
5 143 Base Rock	12:05	12:35		1:22		
6						
7						
8						
9						
10						
11						
12						
13						
14						
15						

8 AM
+ 1/2
8 1/2

REMARKS 1/2 HR Lunch	DRIVER REPORTING TIME	FUEL	COMPUTATION OF HOURLY SERVICE FREIGHT BILL
	SUBTRACT STARTING TIME OF LAST TRIP	= BASE HOURS →	
	ENDING TIME OF LAST TRIP	ELAPSED TIME OF THE RUNNING TIME OF LAST TRIP X 2 =	

STARTING TIME OF UNLOADING OF LAST TRIP	ENDING TIME OF UNLOADING TIME OF LAST TRIP	ELAPSED TIME OF THE UNLOADING TIME OF LAST TRIP
DRIVER SIGNATURE BY [Signature]		
UNDERLYING CARRIER		
ADDRESS		

I agree court costs, 33 1/3% attorney fees, and all costs that arise from any proceedings for the collection of amounts due to the above carrier for work done for the above shipper will be paid by the above shipper. NOT RESPONSIBLE FOR BROKEN SIDEWALKS, CURBS OR OTHER PROPERTY WHEN DELIVERY IS REQUESTED ON PREMISES.

RECEIVED IN GOOD ORDER BY FOREMAN

OVERALL TIME FROM TIME REPORTING FOR WORK TO START OF LAST TRIP PLUS DOUBLE RUNNING TIME OF LAST TRIP PLUS UNLOADING TIME OF LAST TRIP	
SUBTRACT DEDUCTIBLE TIME	
NET CHARGEABLE TIME OR TONS	
MULTIPLY BY TONAGE OR HOURLY RATE	X \$
TOTAL DUE →	

P.U.C. REQUIRES PAYMENTS FOR THESE CHARGES NOT LATER THAN THE 15TH OF THE FOLLOWING MONTH.

WHITE - REV. ACCT. YELLOW - OFFICE PINK - DELIVERY GOLD - SUB HAUL



MONTEREY PENINSULA ENGINEERING

DAILY EXTRA WORK REPORT

BILLING INFORMATION:
 NAME: Sees Maintenance Facility
 ADDRESS: _____
 CITY/STATE/ZIP: _____
 PHONE: _____

DATE PERFORMED 5-20-22

WORK PERFORMED AT THE DIRECTION OF: (Trevor Miller) Sees Maintenance Facility

CONTRACTOR JOB NO. 2212
 CONTRACTOR REPORT NO. 21-865

DESCRIPTION OF WORK: relocate new catch basin. Re-dig trench to install 8" storm drain
 P.P.S.

EQUIPMENT		HOURS	HOURLY/DAILY RATE	EXTENDED AMOUNTS	P.R. NO.	LABOR		HOURS	HOURLY RATE	EXTENDED AMOUNTS
3562	Excavator	8			F	Domingo Navarro		8		
3514	Back hoe	8			L1	Victor Vargas		8		
3398	Crew truck	8			04	Jeff Thuringer		8		
								O.T.		
								REG.		
								O.T.		
								REG.		
								O.T.		
								REG.		
								O.T.		
								REG.		
								O.T.		
								REG.		
MATERIAL AND/OR WORK DONE BY SPECIALISTS										
DESCRIPTION		NO. UNIT	UNIT COST	EXTENDED	SUB-TOTAL					
PAYROLL BURDEN AND/OR MARKUPS										
TOTAL COST OF LABOR										
TOTAL COST OF EQUIPMENT, MATERIALS AND WORK										
<div style="display: flex; justify-content: space-between;"> TOTAL A & B MARKUP ON EQUIPMENT, MATERIAL AND WORK COST _____ % </div>										

CONTRACTOR'S REPRESENTATIVE

ACCEPTED:
 OWNER/AGENT

DAILY EXTRA WORK REPORT

Job#: 2212
Date Performed: 6/11/2022
E#: 21-897
LOG#: 12958
REV 6/29/22

Work Performed by: MONTEREY PENINSULA ENGINEERING, LIC# 972425

Description of Work: BASEROCK FINISH GRADE

EQUIP. NO.	EQUIPMENT	OT/Delay Factor	HOURS		HOURLY RATE	EXTENDED AMOUNTS	LABOR		HOURS	HOURLY RATE	EXTENDED AMOUNTS
			RT	OT			OPERATOR	OT			
3519	CASE 590SN 4WD BH	1	4	0	\$ 70.00	\$ 280.00	OPERATOR 4	4	\$ 81.61	\$ 326.44	
2434	13 INTL 2000 GALLON WATER TRUCK	1	4	0	\$ 75.00	\$ 300.00	GERARDO GAYTAN	2	\$ 81.61	\$ 163.22	
3464	BOMAG BW135AD ROLLER	1	4	0	\$ 55.00	\$ 220.00	OPERATOR 4	2	\$ 59.69	\$ 119.38	
3579	BOBCAT T770 LOADER	1	4	0	\$ 55.00	\$ 220.00	ARMANDO ZAMORA	4	\$ 81.61	\$ 326.44	
1220	08 FORD F250 SD 4X4	1	4	0	\$ 40.00	\$ 160.00	ARMANDO ZAMORA	4	\$ 59.69	\$ 238.76	
1212	13 FORD F250 SD 4X4	1	4	0	\$ 40.00	\$ 160.00	MARCO GALICIA	0	\$ -	\$ -	
0		1	4	0	\$ -	\$ -	BRYAN OLMOS	0	\$ -	\$ -	
0		1	4	0	\$ -	\$ -		0	\$ -	\$ -	
0		1	4	0	\$ -	\$ -		0	\$ -	\$ -	
0		1	4	0	\$ -	\$ -		0	\$ -	\$ -	
0		1	4	0	\$ -	\$ -		0	\$ -	\$ -	
0		1	4	0	\$ -	\$ -		0	\$ -	\$ -	
0		1	4	0	\$ -	\$ -		0	\$ -	\$ -	
0		1	4	0	\$ -	\$ -		0	\$ -	\$ -	
MATERIAL and/or WORK DONE BY SPECIALISTS											
Description	No. Units	Unit Cost	Amount								
BASEROCK 132 TONS TOTAL	132.00	\$15.00	\$1,980.00								
SUNSET PACIFIC	8.00	\$130.00	\$1,040.00								
SUNSET PACIFIC	8.00	\$130.00	\$1,040.00								
	1.00	\$0.00	\$0.00								
	1.00	\$0.00	\$0.00								
	1.00	\$0.00	\$0.00								
FUEL SURCHARGE	\$1,340.00	2% OF EQUIP FEE	\$26.80								
TOTAL COST OF EQUIPMENT, MATERIALS AND WORK			\$26.80								
Sub-Total Labor RT											\$ 1,174.24
Labor Surcharge RT		25%									\$ 293.56
Sub-Total Labor OT											\$ -
Labor Surcharge OT		25%									\$ -
Subsistence											\$ -
TOTAL COST OF LABOR											\$ 1,467.80
TOTAL COST OF EQUIPMENT, MATERIALS AND WORK											
15% MARK-UP ON LABOR COST											
15% MARK-UP ON EQUIP., MATERIAL AND WORK COST											
TOTAL THIS REPORT											
\$ 7,928.79											

479/713
2212 T M 06-01-22 E # 21-897 LOG # 12958



MONTEREY PENINSULA ENGINEERING

DAILY EXTRA WORK REPORT

BILLING INFORMATION:
 NAME:
 ADDRESS:
 CITY/STATE/ZIP:
 PHONE:

DATE PERFORMED 06-01-2022

WORK PERFORMED AT THE DIRECTION OF: SCCS-MAINTENANCE-FACILITY
Baserock Finish grade

CONTRACTOR JOB NO. 2212
 CONTRACTOR REPORT NO. 21-097

EQUIP NO.	EQUIPMENT	HOURS	HOURLY/DAILY RATE	EXTENDED AMOUNTS	P.R. NO.	LABOR	HOURS	HOURLY RATE	EXTENDED AMOUNTS
3679	Backhoe	4				J Gerardo Gayten	8		
2134	120 truck	4				O Armando Zamora	8		
3464	Roller	4				O Masca Galicig	8		
3679	30b cat	8				L Brian Olmos	8		
1220	Utility truck	8							
1242	Utility truck	8							

DESCRIPTION	NO. UNIT	UNIT COST	EXTENDED	SUB-TOTAL
66 Tons Transfer Base Rock		Sunset		
66 Tons Transfer Base Rock		Sunset		
TOTAL COST OF LABOR				
TOTAL COST OF EQUIPMENT, MATERIALS AND WORK				
TOTAL A & B				

CONTRACTOR'S REPRESENTATIVE _____
 OWNER/AGENT _____

ACCEPTED:

MARKUP ON EQUIPMENT, MATERIAL AND WORK COST _____ %

TOTAL THIS REPORT

192 Healy Avenue., Marina, CA 93933 • (831) 384-4115

PUC # T-151856

DATE 10/11/72	MATERIAL Concrete	TYPE OF LOADING	<input type="checkbox"/> BELT <input type="checkbox"/> BUNKER	<input type="checkbox"/> HOT PLANT <input type="checkbox"/> FRONT LOADER	<input type="checkbox"/> OTHER
DESTINATION: WHERE MAT'L DELIVERED 434 Point St		JOB NO. = 7712	TAG NO. 90568		
POINT OF ORIGIN: WHERE MAT'L WAS ORDERED Pine Point yard		EQUIP. NO. 950/7951			

CONSIGNOR: WHO OWNED MAT'L	CONSIGNEE: WHO REC'D MAT'L	CONSIGNOR ADDRESS	CONSIGNEE ADDRESS
DEBTOR: WHO PAYS LBS.	DEBTOR ADDRESS		
LOCATION DRIVER REPORTED 197 West	NO. AXLES 5	MILEAGE	WHEN ZONE RATES APPLY YARD. CAP'Y
PROD. AREA:	DEL. ZONE:	CY	

TAG NUMBER	WEIGHT	LOADING		LEAVE SCALES	UNLOADING	
		ARRIVE	DEPART		ARRIVE	DEPART
1		754	844		920	735
2		1024	1038		1132	1145
3		1110	1251		150	215
4						
5						
6						
7						
8						
9						
10						
11						
12						
13						
14						
15						

66 TON

REMARKS	DRIVER REPORTING TIME 7:00	FUEL:	COMPUTATION OF HOURLY SERVICE FREIGHT BILL
	SUBTRACT STARTING TIME OF LAST TRIP		= BASE HOURS →
	ENDING TIME OF LAST TRIP	ELAPSED TIME OF THE RUNNING TIME OF LAST TRIP	X 2 =

STARTING TIME OF UNLOADING OF LAST TRIP	ENDING TIME OF UNLOADING TIME OF LAST TRIP	ELAPSED TIME OF THE UNLOADING TIME OF LAST TRIP
DRIVER'S SIGNATURE BY	Indred by carrier in good condition as noted.	OVERALL TIME FROM TIME REPORTING FOR WORK TO START OF LAST TRIP PLUS DOUBLE RUNNING TIME OF LAST TRIP PLUS UNLOADING TIME OF LAST TRIP
UNDERLYING CARRIER	ADDRESS	SUBTRACT DEDUCTIBLE TIME
agree court costs, 33 1/3% attorney fees, and all costs that arise from any proceedings for the collection of amounts due to the above carrier for work done for the above shipper will be paid by the above shipper. NOT RESPONSIBLE FOR BROKEN SIDEWALKS, CURBS OR OTHER PROPERTY WHEN DELIVERY IS REQUESTED ON PREMISES.		NET CHARGEABLE TIME OR TONS
		MULTIPLY BY TONAGE OR HOURLY RATE
		X \$
		TOTAL DUE →

RECEIVED IN GOOD ORDER BY FOREMAN

192 Healy Avenue., Marina, CA 93933 • (831) 384-4115

PUC # T-151856

DATE 6-01-27	MATERIAL 1/4 Russ Rock	TYPE OF LOADING	<input type="checkbox"/> BELT <input type="checkbox"/> BUNKER	<input type="checkbox"/> HOT PLANT <input type="checkbox"/> FRONT LOADER	<input type="checkbox"/> OTHER
DESTINATION: WHERE MAT'L DELIVERED Palm St		JOB NO. 2242		TAG NO. 90633	
POINT OF ORIGIN: WHERE MAT'L WAS ORDERED 2nd and 3rd		EQUIP. NO. 227467444			
CONSIGNOR: WHO OWNED MAT'L MPE		CONSIGNOR ADDRESS			
CONSIGNEE: WHO REC'D MAT'L MPE		CONSIGNEE ADDRESS			
DEBTOR: WHO PAYS LBS.		DEBTOR ADDRESS			

LOCATION DRIVER REPORTED	NO. AXLES	MILEAGE	WHEN ZONE RATES APPLY	YARD. CAPY
			PROD. AREA: DEL. ZONE:	CY

TAG NUMBER	WEIGHT	LOADING		LEAVE SCALES	UNLOADING	
		ARRIVE	DEPART		ARRIVE	DEPART
1 Russ Rock		7:30	7:40		8:55	9:30
2 Russ Rock		10:15	10:25		11:25	11:35
3 Russ Rock		12:30	12:40		1:45	2:00
4						
5						
6						
7						
8						
9						
10						
11						
12						
13						
14						
15						

66 TON

REMARKS	DRIVER REPORTING TIME 7:00	FUEL	COMPUTATION OF HOURLY SERVICE FREIGHT BILL
	SUBTRACT STARTING TIME OF LAST TRIP = BASE HOURS →		
	ENDING TIME OF LAST TRIP 7:30	ELAPSED TIME OF THE RUNNING TIME OF LAST TRIP x 2 =	

STARTING TIME OF UNLOADING OF LAST TRIP	ENDING TIME OF UNLOADING TIME OF LAST TRIP	ELAPSED TIME OF THE UNLOADING TIME OF LAST TRIP
DRIVER'S SIGNATURE BY: [Signature]		
UNDERLYING CARRIER		
ADDRESS		
<p>Agree court costs, 33 1/3% attorney fees, and all costs that arise from any proceedings for the collection of amounts due to the above carrier for work done for the above shipper will be paid by the above shipper. NOT RESPONSIBLE FOR BROKEN SIDEWALKS, CURBS OR OTHER PROPERTY WHEN DELIVERY IS REQUESTED ON PREMISES.</p>		
SUBTRACT DEDUCTIBLE TIME		
NET CHARGEABLE TIME OR TONS		
MULTIPLY BY TONAGE OR HOURLY RATE		x \$
TOTAL DUE →		

RECEIVED IN GOOD ORDER BY FOREMAN

P.U.C. REQUIRES PAYMENTS FOR THESE CHARGES NOT LATER THAN THE 15TH OF THE FOLLOWING MONTH.

DAILY EXTRA WORK REPORT

Job#: 2212
Date Performed: 6/2/2022
E#: 21-898
LOG#: 12958
 rev 6/29/22

Work Performed by: MONTEREY PENINSULA ENGINEERING, LIC# 972425

Description of Work: BASEROCK FINISH GRADE

EQUIP. NO.	EQUIPMENT	OT/Delay Factor	HOURS		HOURLY RATE	EXTENDED AMOUNTS	LABOR	HOURS		HOURLY RATE	EXTENDED AMOUNTS
			RT	OT				RT	OT		
3519	CASE 590SN 4WD BIH	1	2		\$ 70.00	\$ 140.00	OPERATOR 4	2		\$ 81.61	\$ 163.22
2434	13 INTL 2000 GALLON WATER TRUCK	1	2		\$ 75.00	\$ 150.00	GERARDO GAYTAN	2		\$ 81.61	\$ 163.22
3464	BOMAG BW136AD ROLLER	1	2		\$ 55.00	\$ 110.00	ARMANDO ZAMORA	2		\$ 59.69	\$ 119.38
3579	BOBCAT T770 LOADER	1	2		\$ 55.00	\$ 110.00	ARMANDO ZAMORA	2		\$ 81.61	\$ 163.22
1220	06 FORD F250 SD 4X4	1	2		\$ 40.00	\$ 80.00	MARCO GALICIA	2		\$ 59.69	\$ 119.38
1242	20 FORD 150 P/U	1	2		\$ 40.00	\$ 80.00	LABOR 1	2		\$ -	\$ -
0	0	1			\$ -	\$ -	ALEX LEYVA	0		\$ -	\$ -
0	0	1			\$ -	\$ -		0		\$ -	\$ -
0	0	1			\$ -	\$ -		0		\$ -	\$ -
0	0	1			\$ -	\$ -		0		\$ -	\$ -
0	0	1			\$ -	\$ -		0		\$ -	\$ -
0	0	1			\$ -	\$ -		0		\$ -	\$ -
0	0	1			\$ -	\$ -		0		\$ -	\$ -
0	0	1			\$ -	\$ -		0		\$ -	\$ -
MATERIAL and/or WORK DONE BY SPECIALISTS											
Description	No. Units		Unit Cost		Amount						
BASEROCK - 110 TONS TOTAL	110.00		\$15.00		\$1,650.00						
90569 SUNSET PACIFIC	8.00		\$130.00		\$1,040.00						
90634 SUNSET PACIFIC	8.00		\$130.00		\$1,040.00						
	1.00		\$0.00		\$0.00						
	1.00		\$0.00		\$0.00						
	1.00		\$0.00		\$0.00						
FUEL SURCHARGE	\$670.00	2% OF EQUIP FEE	\$13.40		\$13.40						
TOTAL COST OF EQUIPMENT, MATERIALS AND WORK							TOTAL COST OF LABOR				
							Sub-Total Labor RT			\$	728.42
							Labor Surcharge RT	25%		\$	182.11
							Sub-Total Labor OT			\$	-
							Labor Surcharge OT	25%		\$	-
							Subsistence			\$	-
							TOTAL COST OF LABOR			\$	910.53
										\$	4,413.40
										\$	136.58
										\$	662.01
										\$	6,122.51
							15% MARK-UP ON LABOR COST				
							15% MARK-UP ON EQUIP., MATERIAL AND WORK COST				
							TOTAL THIS REPORT				



MONTEREY PENINSULA ENGINEERING

DAILY EXTRA WORK REPORT

DATE PERFORMED 06-02-2022

BILLING INFORMATION:
 NAME: _____
 ADDRESS: _____
 CITY/STATE/ZIP: _____
 PHONE: _____

WORK PERFORMED AT THE DIRECTION OF: SCCS-MAINTENANCE-FACILITY
 DESCRIPTION OF WORK: Base rock finish grade

CONTRACTOR JOB NO. 2212
 CONTRACTOR REPORT NO. 21898

EQUIP NO.	EQUIPMENT	HOURS	HOURLY/DAILY RATE	EXTENDED AMOUNTS	P.R. NO.	LABOR	HOURS	HOURLY RATE	EXTENDED AMOUNTS
3419	Back hoe	4			6	Gerardo Geytan	8		
2834	H2O truck	4			10	Armando Zamora	8		
3164	Roller	4			0	Marco Galicig	8		
3679	Bob Cat	8			4	Alex Leiva	8		
1220	Utility truck	8					8		
1242	Utility truck	8					8		

MATERIAL AND/OR WORK DONE BY SPECIALISTS			SUB-TOTAL	
DESCRIPTION	NO. UNIT	UNIT COST	EXTENDED	
6 Tons Transfer Base Rock		Sunset		
4 Tons Transfer Base Rock		Sunset		
TOTAL COST OF EQUIPMENT, MATERIALS AND WORK				A
TOTAL COST OF LABOR				B

TOTAL A & B _____
 MARKUP ON EQUIPMENT, MATERIAL AND WORK COST _____ %
TOTAL THIS REPORT

CONTRACTOR'S REPRESENTATIVE

ACCEPTED:

OWNER/AGENT

192 Healy Avenue., Marina, CA 93933 • (831) 384-4115

PUC # T-151856

DATE 12/22	MATERIAL	TYPE OF • <input type="checkbox"/> BELT LOADING • <input type="checkbox"/> BUNKER	<input type="checkbox"/> HOT PLANT <input type="checkbox"/> FRONT LOADER	<input type="checkbox"/> OTHER
DESTINATION: WHERE MAT'L DELIVERED	Cresta Marina SC	JOB NO. = 7212	TAG NO. 90569	
POINT OF ORIGIN: WHERE MAT'L WAS ORDERED	10th & 3rd Yard	EQUIP. NO. 2450/045		
CONSIGNOR: WHO OWNED MAT'L	W&A	CONSIGNOR ADDRESS		
CONSIGNEE: WHO REC'D MAT'L	W&A	CONSIGNEE ADDRESS		
DEBTOR: WHO PAYS LBS.		DEBTOR ADDRESS		
LOCATION DRIVER REPORTED	NO. AXLES	MILEAGE	WHEN ZONE RATES APPLY PROD. AREA: DEL. ZONE:	YARD. CAPY CY

TAG NUMBER	WEIGHT	LOADING		LEAVE SCALES	UNLOADING	
		ARRIVE	DEPART		ARRIVE	DEPART
1	1	770	773		830	847
2		901	902		1039	1056
3	5121	1056	1115			
4						
5						
6						
7						
8						
9						
10						
11						
12						
13						
14						
15						

44 TON

REMARKS	DRIVER REPORTING TIME 11:45	FUEL	COMPUTATION OF HOURLY SERVICE FREIGHT BILL
	SUBTRACT STARTING TIME OF LAST TRIP	= BASE HOURS →	
	ENDING TIME OF LAST TRIP	ELAPSED TIME OF THE RUNNING TIME OF LAST TRIP X 2 =	
STARTING TIME OF UNLOADING OF LAST TRIP	ENDING TIME OF UNLOADING TIME OF LAST TRIP	ELAPSED TIME OF THE UNLOADING TIME OF LAST TRIP	
DRIVER'S SIGNATURE BY	Rec'd by carrier in good condition as noted.	OVERALL TIME FROM TIME REPORTING FOR WORK TO START OF LAST TRIP PLUS DOUBLE RUNNING TIME OF LAST TRIP PLUS UNLOADING TIME OF LAST TRIP	
UNDERLYING CARRIER		SUBTRACT DEDUCTIBLE TIME	
ADDRESS		NET CHARGEABLE TIME OR TONS	
agree court costs, 33 1/3% attorney fees, and all costs that arise from any proceedings for the collection of amounts due to the above carrier for work done for the above shipper will be paid by the above shipper. NOT RESPONSIBLE FOR BROKEN SIDEWALKS, CURBS OR OTHER PROPERTY WHEN DELIVERY IS REQUESTED ON PREMISES.		MULTIPLY BY TONAGE OR HOURLY RATE X \$	
		TOTAL DUE →	

RECEIVED IN GOOD ORDER BY FOREMAN

P.U.C. REQUIRES PAYMENTS FOR THESE CHARGES NOT LATER THAN THE 15TH OF THE FOLLOWING MONTH.

192 Healy Avenue., Marina, CA 93933 • (831) 384-4115

DATE: 5-20-72 MATERIAL: TYPE OF: BELT HOT PLANT OTHER
 LOADING: BUNKER FRONT LOADER

DESTINATION: HERE MAT'L DELIVERED: PUMP STATION JOB NO. 2212 TAG NO. 90634
 POINT OF ORIGIN: HERE MAT'L WAS ORDERED: EQUIP. NO. 244034

CONSIGNOR: ADDRESS: WHO OWNED MAT'L: CONSIGNEE: ADDRESS: WHO REC'D MAT'L: DEBTOR: ADDRESS: WHO PAYS LBS.:

LOCATION DRIVER REPORTED NO. AXLES MILEAGE WHEN ZONE RATES APPLY YARD CAP'Y
 PROD. AREA: DEL. ZONE: CY

TAG NUMBER	WEIGHT	LOADING		LEAVE SCALES	UNLOADING	
		ARRIVE	DEPART		ARRIVE	DEPART
1		6:15	6:35		6:50	
2						
3		8:05	8:05		8:50	9:10
4						
5		9:20	9:49		10:15	10:29
6						
7		11:00	11:15		12:10	12:18
8		11:08	11:18		12:28	12:38
9						
10						
11						
12						
13						
14						
15						

66 TON

REMARKS: DRIVER REPORTING TIME: 6:30 FUEL: COMPUTATION OF HOURLY SERVICE FREIGHT BILL:
 SUBTRACT STARTING TIME OF LAST TRIP = BASE HOURS →
 ENDING TIME OF LAST TRIP ELAPSED TIME OF THE RUNNING TIME OF LAST TRIP X 2 =

STARTING TIME OF UNLOADING OF LAST TRIP: ENDING TIME OF UNLOADING TIME OF LAST TRIP: ELAPSED TIME OF THE UNLOADING TIME OF LAST TRIP:
 DRIVER'S SIGNATURE BY: JUAN... (Rec'd by carrier in good condition as noted.)
 UNDERLYING CARRIER: NET CHARGEABLE TIME OR TONS: MULTIPLY BY TONAGE OR HOURLY RATE: X \$
 TOTAL DUE →

RECEIVED IN GOOD ORDER BY FOREMAN
 C. REQUIRES PAYMENTS FOR THESE CHARGES NOT LATER THAN THE 15TH OF THE FOLLOWING MONTH.

DAILY EXTRA WORK REPORT

Job#: 2212

Date Performed: 6/3/2022

E#: 21-899

LOG#: 12958

rev 6/29/22

Work Performed by: MONTEREY PENINSULA ENGINEERING, LIC# 972425

Description of Work: BASEROCK FINISH GRADE

EQUIP. NO.	EQUIPMENT	OT/Delay Factor	HOURS		HOURLY RATE	EXTENDED AMOUNTS	LABOR	HOURS		HOURLY RATE	EXTENDED AMOUNTS
			RT	OT				RT	OT		
3519	CASE 590SN 4WD BH	1	2		\$ 70.00	\$ 140.00	OPERATOR 4	2		\$ 81.61	\$ 163.22
2434	13 INTL 2000 GALLON WATER TRUCK	1	2		\$ 75.00	\$ 150.00	GERARDO GAYTAN				
3464	BOMAG BW135AD ROLLER	1	2		\$ 55.00	\$ 110.00	OPERATOR 4	1		\$ 81.61	\$ 81.61
3579	BOBCAT T770 LOADER	1	2		\$ 55.00	\$ 110.00	ARMANDO ZAMORA	1		\$ 59.69	\$ 59.69
1220	08 FORD F250 SD 4X4	1	2		\$ 40.00	\$ 80.00	ARMANDO ZAMORA	2		\$ 81.61	\$ 163.22
1242	20 FORD 150 PU	1	2		\$ 40.00	\$ 80.00	MARCO GALICIA	2		\$ 59.69	\$ 119.38
0	0	1	RT	OT	\$ -	\$ -	LABOR 1	2		\$ -	\$ -
0	0	1	RT	OT	\$ -	\$ -	JESUS ZAMORA	2		\$ -	\$ -
0	0	1	RT	OT	\$ -	\$ -	0	0		\$ -	\$ -
0	0	1	RT	OT	\$ -	\$ -	0	0		\$ -	\$ -
0	0	1	RT	OT	\$ -	\$ -	0	0		\$ -	\$ -
0	0	1	RT	OT	\$ -	\$ -	0	0		\$ -	\$ -
0	0	1	RT	OT	\$ -	\$ -	0	0		\$ -	\$ -
0	0	1	RT	OT	\$ -	\$ -	0	0		\$ -	\$ -
0	0	1	RT	OT	\$ -	\$ -	0	0		\$ -	\$ -
0	0	1	RT	OT	\$ -	\$ -	0	0		\$ -	\$ -
0	0	1	RT	OT	\$ -	\$ -	0	0		\$ -	\$ -
0	0	1	RT	OT	\$ -	\$ -	0	0		\$ -	\$ -
0	0	1	RT	OT	\$ -	\$ -	0	0		\$ -	\$ -
MATERIAL and/or WORK DONE BY SPECIALISTS											
Description			No. Units		Unit Cost	Amount					
BASEROCK 48 TONS			48.00		\$15.00	\$720.00					
41953 WILSON & SON TRUCKING			8.00		\$130.00	\$1,040.00					
			1.00		\$0.00	\$0.00					
			1.00		\$0.00	\$0.00					
			1.00		\$0.00	\$0.00					
			1.00		\$0.00	\$0.00					
			1.00		\$0.00	\$0.00					
FUEL SURCHARGE			\$670.00	2% OF EQUIP FEE	\$13.40	\$13.40					
TOTAL COST OF EQUIPMENT, MATERIALS AND WORK							TOTAL COST OF LABOR				
							Sub-Total Labor RT			\$	587.12
							Labor Surcharge RT	25%		\$	146.78
							Sub-Total Labor OT			\$	-
							Labor Surcharge OT	25%		\$	-
							Subsistence			\$	-
							TOTAL COST OF LABOR			\$	733.90
15% MARK-UP ON LABOR COST										\$	2,443.40
15% MARK-UP ON EQUIP., MATERIAL AND WORK COST										\$	110.09
TOTAL THIS REPORT										\$	366.51
										\$	3,653.90



MONTEREY PENINSULA ENGINEERING

DAILY EXTRA WORK REPORT

DATE PERFORMED 06-03-2022

BILLING INFORMATION:
 NAME: _____
 ADDRESS: _____
 CITY/STATE/ZIP: _____
 PHONE: _____

WORK PERFORMED AT THE DIRECTION OF: SCCS-MAINTENANCE-FACILITY
 DESCRIPTION OF WORK: Base rock Finish grade

CONTRACTOR JOB NO. 2212
 CONTRACTOR REPORT NO. 21-899

EQUIP NO.	EQUIPMENT	HOURS	HOURLY/DAILY RATE	EXTENDED AMOUNTS	P.R. NO.	LABOR	HOURS	HOURLY RATE	EXTENDED AMOUNTS	MATERIAL AND/OR WORK DONE BY SPECIALISTS	
										NO. UNIT	UNIT COST
3619	Backhoe	4			6	Gerardo Cortez					
2734	H20 Truck	4			0	Armando Zamora					
3460	Roller	4			0	Marco Galicig					
3679	Bobcat	8			1	Jesus Zamora					
1220	Utility truck	8									
1242	Utility truck	8									
<p>MATERIAL AND/OR WORK DONE BY SPECIALISTS</p>											
48	Tons Super 10 Base Rock										WILSON TRUCKING
<p>TOTAL COST OF EQUIPMENT, MATERIALS AND WORK</p>											
<p>TOTAL COST OF LABOR</p>											A
<p>TOTAL A & B</p>											B

PAYROLL BURDEN AND/OR MARKUPS

TOTAL A & B
 MARKUP ON EQUIPMENT, MATERIAL AND WORK COST _____ %
 TOTAL THIS REPORT

CONTRACTOR'S REPRESENTATIVE

OWNER/AGENT

ACCEPTED:



WILSON & SON TRUCKING

11933

12195 St Moritz Way • Salinas, CA 93906 • Bus/Home: (831) 443-1882 • Fax: (831) 444-6540

DATE <i>10/11/00</i>	MATERIAL <i>Gravel</i>	TYPE OF LOADING <input type="checkbox"/> BELT <input type="checkbox"/> BUNKER <input type="checkbox"/> HOT PLANT <input checked="" type="checkbox"/> FRONT LOADER <input type="checkbox"/> OTHER
DESTINATION: WHERE MAT'L DELIVERED		JOB NO. <i>2212</i>
POINT OF ORIGIN: WHERE MAT'L LOADED		EQUIP. NO. <i>1</i> GX NO.
CONSIGNOR: WHO OWNED MAT'L	<input type="checkbox"/> TEN WHEELER <input type="checkbox"/> BOTTOM DUMP <input type="checkbox"/> TRANSFER <input type="checkbox"/> FLAT BED <input checked="" type="checkbox"/> SUPERTEN <input type="checkbox"/> DRY BOX <input type="checkbox"/> END DUMP <input type="checkbox"/> OTHER	
CONSIGNEE: WHO REC'D MAT'L		
DEBTOR: WHO PAYS LBS		
LOCATION DRIVER REPORTED	NO AXLES	MILEAGE
		WHEN ZONE RATES APPLY
	PROG AREA	DEL. ZONE
		YARD CAPY

TAG NUMBER	WEIGHT	LOADING		LEAVING SCALES	UNLOADING	
		ARRIVE	DEPART		ARRIVE	DEPART
1	<i>20000</i>	<i>7:30</i>			<i>9:10</i>	<i>9:10</i>
2	<i>20000</i>	<i>9:00</i>			<i>10:40</i>	<i>10:40</i>
3	<i>20000</i>	<i>10:00</i>			<i>11:40</i>	<i>11:40</i>
4	<i>20000</i>	<i>11:00</i>	<i>12:00</i>		<i>1:40</i>	<i>2:00</i>
5	<i>20000</i>	<i>12:00</i>	<i>1:00</i>		<i>2:40</i>	<i>3:00</i>
6	<i>20000</i>	<i>1:00</i>	<i>2:00</i>		<i>3:40</i>	<i>4:00</i>
7	<i>20000</i>	<i>2:00</i>	<i>3:00</i>		<i>4:40</i>	<i>5:00</i>
8	<i>20000</i>	<i>3:00</i>	<i>4:00</i>		<i>5:40</i>	<i>6:00</i>
9	<i>20000</i>	<i>4:00</i>	<i>5:00</i>		<i>6:40</i>	<i>7:00</i>
10	<i>20000</i>	<i>5:00</i>	<i>6:00</i>		<i>7:40</i>	<i>8:00</i>
11	<i>20000</i>	<i>6:00</i>	<i>7:00</i>		<i>8:40</i>	<i>9:00</i>
12	<i>20000</i>	<i>7:00</i>	<i>8:00</i>		<i>9:40</i>	<i>10:00</i>
13	<i>20000</i>	<i>8:00</i>	<i>9:00</i>		<i>10:40</i>	<i>11:00</i>

REMARKS	DRIVER REPORTING TIME <i>7:00</i>	FUEL	COMPUTATION OF HOURLY SERVICE FREIGHT BILL
SUBTRACT STARTING TIME OF LAST TRIP		BASE HOURS →	
ENDING TIME OF LAST TRIP		ELAPSED TIME OF THE RUNNING TIME OF LAST TRIP	X 2 =
STARTING TIME OF UNLOADING OF LAST TRIP	ENDING TIME OF UNLOADING TIME OF LAST TRIP	ELAPSED TIME OF THE UNLOADING TIME OF LAST TRIP	
DRIVER'S SIGNATURE	BY	Overall Time from Time reporting for work To start of last trip plus double running time Of last trip plus unloading time of last trip	
UNDERLYING CARRIER	ADDRESS	SUBTRACT DEDUCTIBLE TIME	
I agree court costs, 33 1/3% attorney fees, and all costs that arise from any proceedings for the collection of the amounts due to the above carrier for work done for the above shipper will be paid by the above shipper. NOT RESPONSIBLE FOR BROKEN SIDEWALKS, CURBS OR OTHER PROPERTY WHEN DELIVERY IS REQUESTED ON PREMISES.		NET CHARGEABLE TIME OR TONS	
BY <i>[Signature]</i>		MULTIPLY BY TONAGE OR HOURLY RATE	X \$
RECEIVED IN GOOD ORDER BY FOREMAN		TOTAL DUE →	

489/713

SANTA CRUZ CITY SCHOOL DISTRICT

AGENDA ITEM: Netxperts Proposal for DeLaveaga Elementary and Westlake Elementary School Door Hardware Installation

MEETING DATE: August 17, 2022

FROM: Jim Monreal, Assistant Superintendent, Business Services

THROUGH: Kris Munro, Superintendent

RECOMMENDATION:

Ratify Netxperts Inc. proposal for DeLaveaga Elementary and Westlake Elementary School door hardware installation.

BACKGROUND:

The Board previously approved and the District purchased hardware for a keyless electronic lock system. This proposal is for the installation of the door hardware at DeLaveaga and Westlake Elementary Schools. This is part of the District Wide plan for site security and key management. This issue arose over the summer break and required immediate action.

DeLaveaga - Site Security	
SecureAll – Door Hardware	\$164,223.56 (approved & budgeted)
Netxperts Routers	\$12,791.35 (approved and budgeted)
Netxperts Install/Programming	\$37,295.50 (<i>this agenda item</i>)
Estimated Total	\$214,310.41

Westlake - Site Security	
SecureAll Door Hardware	\$177,527.46 (approved & budgeted)
Netxperts Routers	\$10,697.34
Netxperts – Install/Programming	\$37,295.50 (<i>this agenda item</i>)
Estimated Total	\$225,520.30

FISCAL IMPACT:

\$74,591.00, Total

Cost Breakdown by fund:

\$37,295.50 DeLaveaga Elementary School, Measure B Funds (Restricted)

\$37,295.50 Westlake Elementary School, Measure B Funds (Restricted)

This work is in direct support of the following District goals and their corresponding metrics:

Goal #2: SCCS will create positive, engaging school environments that promote the development of cognitive skills and the social emotional well-being of all students.

Goal #5: SCCS will maintain a balanced budget and efficient and effective management.

Goal #6: SCCS will maintain strong communication and partnership with its diverse community.

Prepared by Trevor Miller, Director, Facility Services



NetXperts Inc.
 1777 Botelho Drive Suite 102
 Walnut Creek, CA 94596
 925-806-0800 Tel
 925-806-0899 Fax

QUOTE

Quote # NETQ19787
 Date 06/29/22
 Sales Rep. ngretowski

Quote To:

Santa Cruz City Schools
 Trevor Miller
 536 Palm Street
 Santa Cruz
 CA 95060
 (831) 429-3904
 trevormiller@sccs.net

Ship To:

Santa Cruz City Schools
 Trevor Miller
 536 Palm Street
 Santa Cruz
 CA 95060
 (831) 429-3904
 trevormiller@sccs.net

Qty	Part Number	Description	Unit Price	Ext. Price
-----	-------------	-------------	------------	------------

Santa Cruz City Schools

**Locations: DeLaveaga
 Elementary, Westlake
 Elementary**

Materials

1	MISC	Misc. items such as; bolts, screws, cleaning supplies, etc.	\$1,200.00	\$1,200.00
---	------	---	------------	------------

Professional Services

1	NPS	Door lock installation and troubleshooting (303 door locks)	\$48,480.00	\$48,480.00
1	NPS	Travel and expenses such as Hotel, Gas and Per diem.	\$17,000.00	\$17,000.00
1	NPS	Project Management to be the main point of contact and to oversee the installation process, documentation, and other customer needs.	\$7,800.00	\$7,800.00

SubTotal	\$74,480.00
Sales Tax	\$111.00
Shipping	\$0.00

Signature  Date 07/12/22

Please indicate acceptance of terms by signing above.

Total \$74,591.00

Terms & Conditions of this Proposal: All orders will be placed upon receipt of signed purchase order or a signed contract between NetXperts, Inc. and customer. Such purchase order or contract will be subject to any governing law. All hardware is warranted per manufacturer's published warranty only, unless an NetXperts Service Contract has been purchased. This order may be subject to: sales tax, VAT, duty and freight charges even if not noted on this quote. Terms for Hardware, Software are Net 30. FOB Origin; Title passes at origin, and buyer has total responsibility over the goods while in shipment. NetXperts Inc. - Confidential and Proprietary

SANTA CRUZ CITY SCHOOL DISTRICT

AGENDA ITEM: Overhead Door Proposal Harbor High School Door Repair

MEETING DATE: August 17, 2022

FROM: Jim Monreal, Assistant Superintendent, Business Services

THROUGH: Kris Munro, Superintendent

RECOMMENDATION:

Approve Overhead Door proposal for Harbor High School door repair.

BACKGROUND:

This proposal consists of parts and labor to restore proper operation to the roll up doors at the multi-purpose room at Harbor High School. One of the doors has recently failed and is inoperable. All of the roll up doors at Harbor High School will be assessed and needed maintenance will be done through this contract.

FISCAL IMPACT:

\$5,332.00 Measure A Funds (Restricted), representing 0.01% of the overall site budget
\$28,554,079.00 is the total Bond Allocation to Harbor High School

This work is in direct support of the following District goals and their corresponding metrics:

Goal #2: SCCS will create positive, engaging school environments that promote the development of cognitive skills and the social emotional well-being of all students.

Goal #5: SCCS will maintain a balanced budget and efficient and effective management.

Goal #6: SCCS will maintain strong communication and partnership with its diverse community.

Prepared by Trevor Miller, Director, Facility Services



Overhead Door Company of Salinas

733 Sanborn Place
Salinas, CA 93901-4569
www.odcsalinas.com

Contact: Ritchie Stockton
Phone: 831-422-3667
Email: ritich_stockton@odcsalinas.com

This proposal is valid till Tuesday, August 9, 2022

Quote: SQGR001887-1 | Created: 8/2/2022 8:02 AM

Job:

HARBOR HIGH SCHOOL

Prepared For:

SANTA CRUZ CITY SCHOOLS



Item	Qty
1 REPLACEMENT.CS	1
REPLACEMENT COMPONENT:	
SECTIONS: 521, 12' 2" x 24", Standard Panel, Clear Anodized, 1 Sect, 4 Pnl, Extra Center	
Stiles: 1, SES, Std Btm Seal	
LITES: Custom, S1: Solid Aluminum Panels	
RAILS: Top: 2.375", Bottom: 3.750"	
Comment: DOOR #1- REPLACE BOTH DOOR CABLES AND BOTH BOTTOM FIXTURES.	
2 MISCELLANEOUS REPAIR PARTS	1
Description: MISCELLANEOUS REPAIR PARTS	
Details: SERVICE (2) ADDITIONAL SECTIONAL DOORS,REPLACE PARTS WHERE NEEDED.	

Total (USD):

\$5,332.00

- Final field check required before ordering material
- Includes tax, labor and installation.
- Price is based on non-union, non-prevailing wage install.
- Due to rapidly rising material, labor, and freight costs, as well as the continued impact of COVID-19, price subject to change

SANTA CRUZ CITY SCHOOL DISTRICT

AGENDA ITEM: San Lorenzo Lumber Proposal for Facilities Door Hardware

MEETING DATE: August 17, 2022

FROM: Jim Monreal, Assistant Superintendent, Business Services

THROUGH: Kris Munro, Superintendent

RECOMMENDATION:

Ratify San Lorenzo Lumber proposal for facilities door hardware.

BACKGROUND:

This proposal consists of new panic exit devices to replace existing non-code compliant devices. This door hardware will work with the new electronic key card system. This issue arose over the summer break and required immediate action.

DATA STORAGE ARRAY	\$47,458.33 (approved & budgeted)
TELECOMMUNICATION SERVICES EQUIPMENT	\$834,239.83 (approved & budgeted)
NETWORK COORDINATION CONSULTING	\$35,520.00 (approved & budgeted)
KEYCARD CREATION	\$13,246.00 (approved & budgeted)
ROUTER INSTALLATION	\$150,925.55 (approved & budgeted)
MAGICARD PRINTER & PROXY CARDS	\$3,394.55 (approved & budgeted)
DISTRICT WIDE DOOR HARDWARE	\$2,006,429.00 (approved & budgeted)
DISTRICT ROUTERS	\$31,709.46 (approved & budgeted)
KEY CARD SYSTEM SET UP	\$53,280.00 (agenda item 8.3.11)
FACILITIES DOOR HARDWARE	\$13,698.68 (This agenda Item)
KEY CARDS	\$4,140.58 (agenda item 8.3.14)
Estimated Total	\$3,194,041.98

FISCAL IMPACT:

\$13,698.68 Total

Cost Breakdown by fund:

\$9,178.12 Measure A (Restricted)

\$4,520.56 Measure B (Restricted)

This work is in direct support of the following District goals and their corresponding metrics:

AGENDA ITEM: 8.3.21.

Goal #2: SCCS will create positive, engaging school environments that promote the development of cognitive skills and the social emotional well-being of all students.
Goal #5: SCCS will maintain a balanced budget and efficient and effective management.
Goal #6: SCCS will maintain strong communication and partnership with its diverse community.

Prepared by Trevor Miller, Director, Facility Services

San Lorenzo Door Shop
 2435-41st Ave
 Soquel CA, 95073
 831-889-6152
 Quoted by: Don Rutter

San Lorenzo

LUMBER & HOME CENTERS



Date: 7/13/2022
 Lead Time: 2- weeks

Email: don.rutter@sanlorenzolumber.com

Page 1 of 1

Dealer: San Lorenzo Door

Attention: S. C. City Schools

Ref: Antonio 831-212-6502

#	Size	Description	Qty	Price	Total
	36"	Von Duppin 99 Series Panic Exit Hardware #99EO36 us26D Satin Chrome	10	1,256.76	\$12,567.60
					\$0.00
					\$0.00
					\$0.00
					\$0.00
		CUSTOMER APPROVAL			
		<i>[Signature]</i>			
		sub total			\$12,567.60
		9 % Sales tax			\$1,131.08
		Grand Total			\$13,698.68
		PO# 00190 (STELL)			

****NOTES****

[Signature]
 07/13/22

Prices good for acceptance within 30 days unless extended in writing

SANTA CRUZ CITY SCHOOL DISTRICT

AGENDA ITEM: SC Systems Proposal for Portable Building Electrical and IDF Demolition

MEETING DATE: August 17, 2022

FROM: Jim Monreal, Assistant Superintendent, Business Services

THROUGH: Kris Munro, Superintendent

RECOMMENDATION:

Ratify SC Systems proposal for portable building electrical and IDF demolition.

BACKGROUND:

This proposal consists of disconnection of all electrical to seven portables at Bay View Elementary School and the relocation of the IDF cabinets, as well as the disconnection of all electrical to three portables at DeLaveaga Elementary School. This issue arose over the summer break and required immediate action.

FISCAL IMPACT:

\$10,000.00 TOTAL

Cost Breakdown by Site:

\$2,800.00 Measure B Funds (Restricted), Bay View Elementary School

\$7,200.00 Measure A Funds (Restricted), DeLaveaga Elementary School

This work is in direct support of the following District goals and their corresponding metrics:

Goal #2: SCCS will create positive, engaging school environments that promote the development of cognitive skills and the social emotional well-being of all students.

Goal #5: SCCS will maintain a balanced budget and efficient and effective management.

Goal #6: SCCS will maintain strong communication and partnership with its diverse community.

Prepared by Trevor Miller, Director, Facility Services

AGENDA ITEM: 8.3.22.



PROPOSAL

THE FOLLOWING IS A PROPOSAL FOR:

Santa Cruz City Schools
De Laveaga Portable Demo

SCOPE OF WORK:

Safe off fire alarm, clock / speaker, security, and network from 3 portables schedule to be removed. Pull systems back to nearest underground junction box. Remove network cable from IDF and prep for removal. Demo interior system cable. Delete fire alarm devices from programming.

PARTS:

NA

All installation, programming and testing for the above scope shall be included in this proposal and performed in a workmanlike manner to applicable codes. Work shall be performed during straight time hours.

Any additions or changes to the above scope must be agreed upon by *Santa Cruz City Schools* and *SC Systems*. The only inclusions in this proposal are the ones listed above. Any additional work not included in this proposal, but required by the local inspector or other authority, shall be subject to additional charges.

This proposal incorporates *SC Systems* general terms and conditions. Progress payments shall be billed at a maximum of 30-day intervals for the value of work and material furnished. Final payment shall be due no later than 30 days after the work described in the Proposal is substantially complete.

PRICE: \$2800

CUSTOMER ACCEPTANCE OF THE ABOVE TERMS:

Customer Signature

A handwritten signature in blue ink, appearing to be "J. Amador", written over a horizontal line.

Date

07/05/22



PROPOSAL

THE FOLLOWING IS A PROPOSAL FOR:

Santa Cruz City Schools
Bay View Elementary Portable Demo / IDF Relocate

SCOPE OF WORK:

Safe off fire alarm, clock / speaker, security, and network from 7 portables schedule to be removed. Pull systems feeds back to nearest underground junction box and safe off. Remove existing Wireless Access Points from each of the 7 rooms for return to the district. Relocate IDF 27 to classroom 20. Remove IDF cabinet from portable 30 and install in room 20. Reroute existing 12 strand fiber and network drops to IDF in Rm. 20. Re terminate fiber and category cables. Install existing switch, fiber housing and patch panel into IDF. Run new network drops to Rm. 21/22 if needed. Test fiber and network drops.

PARTS:

12 – Single Mode LC Fiber Connectors
10 – Panduit Category 6 Mini-Com Jacks

All installation, programming and testing for the above scope shall be included in this proposal and performed in a workmanlike manner to applicable codes. Work shall be performed during straight time hours.

Any additions or changes to the above scope must be agreed upon by *Santa Cruz City Schools* and *SC Systems*. The only inclusions in this proposal are the ones listed above. Any additional work not included in this proposal, but required by the local inspector or other authority, shall be subject to additional charges.

This proposal incorporates *SC Systems* general terms and conditions. Progress payments shall be billed at a maximum of 30-day intervals for the value of work and material furnished. Final payment shall be due no later than 30 days after the work described in the Proposal is substantially complete.

PRICE: \$7200

CUSTOMER ACCEPTANCE OF THE ABOVE TERMS:

Customer Signature

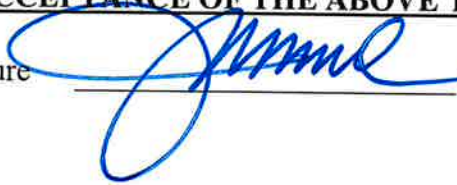

Date

07/05/22

SANTA CRUZ CITY SCHOOL DISTRICT

AGENDA ITEM: Verde Design Change Order #2 for Santa Cruz High School
Baseball Backstop Modifications

MEETING DATE: August 17, 2022

FROM: Jim Monreal, Assistant Superintendent, Business Services

THROUGH: Kris Munro, Superintendent

RECOMMENDATION:

Ratify Verde Design change order #2 for Santa Cruz High School baseball backstop modifications.

BACKGROUND:

This change order consists of additional services as required by the Division of State Architect. During the project submittal review, the Division of State Architect required additional American with Disabilities Act site review including assessment of existing site restrooms, bathing facilities and parking on the Santa Cruz High School Campus. This additional information requirement included the accessible path of travel between these facilities and the proposed backstop improvements. When the project was bid, the District believed that this project would be limited to structural safety review only. The previously approved contract amount was \$38,255.00 and the new total contract, including this change order, will be \$43,535.00. This issue arose over the summer break and required immediate action.

FISCAL IMPACT:

Change Order #2 \$5,280.00 (13.80% increase to the contract), Measure A Funds (Restricted)

This work is in direct support of the following District goals and their corresponding metrics:

Goal #2: SCCS will create positive, engaging school environments that promote the development of cognitive skills and the social emotional well-being of all students.

Goal #5: SCCS will maintain a balanced budget and efficient and effective management.

Goal #6: SCCS will maintain strong communication and partnership with its diverse community.

Prepared by Trevor Miller, Director, Facility Services

AGENDA ITEM: 8.3.23.

June 29, 2022



VERDE DESIGN

Mr. Trevor Miller
Santa Cruz City Schools
536 Palm St
Santa Cruz, CA 95060

2455 The Alameda, Suite 200
Santa Clara, CA 95050
t 408.985.7200 f 408.985.7260
www.verdedesigninc.com

SUBJECT: Additional Service Request 002 - SCHS Baseball Backstop
Additional DSA Revisions
Verde Design Proposal No. 2109002

Dear Trevor:

In response to your request, Verde Design, Inc. is submitting the following additional service request for services not included in the original contract with the Santa Cruz City School District (District).

This request for additional services is related to an expanded scope of work related to accessibility upgrades as noted by the Division of State Architect (DSA) for compliance with current CBC code requirements. The expanded scope of work includes the incorporation of accessibility details that were included in the Portables Relocation Plans (App No 01-119772), but were not corrected during the construction process for that project.

These scope changes were brought to the attention of Chris Garcia, in your absence. We discussed the scope of work to include parking lot striping and signage, truncated domes, student and staff restroom fixture upgrades, and drinking fountain retrofit. It was noted that this would require additional drafting of plans and details to provide adequate information for DSA. Chris recommended that we include these updated plans and details within the Backstop Renovation Project, which we did in order to resubmit to DSA for backcheck.

PROFESSIONAL COMPENSATION

For the scope of services and products identified in this proposal, Verde Design respectfully requests the following lump sum fee

<u>Additional DSA Plan/Detail Preparation</u>	\$ 5,280.00
Total Additional Service Fee	\$ 5,280.00

Trevor, if this proposal meets with the approval of the District, please sign the proposal below. Thank you again for the opportunity to work with Santa Cruz City Schools.

Respectfully Submitted,
Verde Design, Inc.

Approved:

Mark Baginski, RLA
Principal

Name:
Date: 07/12/22

SANTA CRUZ CITY SCHOOL DISTRICT

AGENDA ITEM: WallaceKuhl & Associates Proposal for Soquel High School Fitness Modernization Special Inspection Services

MEETING DATE: August 17, 2022

FROM: Jim Monreal, Assistant Superintendent, Business Services

THROUGH: Kris Munro, Superintendent

RECOMMENDATION:

Ratify WallaceKuhl & Associates proposal for Soquel High School Fitness Modernization special inspection services.

BACKGROUND:

This proposal consists of special inspection services for shop fabrication for the Soquel High School Fitness Room Modernization as required by the Division of State Architect. This issue arose over the summer break and required immediate action.

FISCAL IMPACT:

\$5,000.00 Measure A Funds (Restricted), representing 0.01% of the overall site budget
\$34,830,967.00 is the total Bond Allocation to Soquel High School

This work is in direct support of the following District goals and their corresponding metrics:

Goal #2: SCCS will create positive, engaging school environments that promote the development of cognitive skills and the social emotional well-being of all students.

Goal #5: SCCS will maintain a balanced budget and efficient and effective management.

Goal #6: SCCS will maintain strong communication and partnership with its diverse community.

Prepared by Trevor Miller, Director, Facility Services

June 21, 2022

DSA File No. 44-H2
DSA App. No. 01-119807
LEA No. 227

Mr. Chris Garcia
Santa Cruz City Schools
133 Mission St #100
Santa Cruz, CA 95060
Via email: cgarcia@sccs.net

Cost Proposal – Special Inspection Services – Shop Fabrication Only
SCCS SOQUEL HS INC 1 FITNESS ROOM MODERNIZATION
401 Soquel San Jose Rd
Soquel, California

Wallace-Kuhl and Associates is pleased to submit this proposal to provide shop fabrication special inspection services for the subject project. It is our understanding that all other special inspection and testing services – including earthwork, pavements, drilled pier foundations, and reinforced concrete – will be covered by others and are not included in our proposal. We will prepare the DSA required documentation following our inspections.

Based on our discussions with project personnel and our review of the plans and DSA 103 form, we estimate that our fee for this project would be less than \$5000. Billing would be only for work performed and determined based on the attached 2022P Schedules of Fees. Please be aware that we bill for our hourly services on a portal-to-portal basis from our nearest office. Also, the construction schedule and the contractor's efficiency affect the number of site visits - and the cost - required for our services. We will work with the Project Inspector to provide our services in a timely and efficient manner.

In order to provide the most efficient and responsive service, scheduling for inspections must be made at least 24 hours in advance of the work. In addition, it is considered essential that the contractor be notified well in advance of your intention to have special inspection and testing performed, so that they are prepared for the required inspections. Please notify us immediately if the inspection is canceled so that you do not incur a trip charge.

To assure that all parties fully understand the limitations of our role in your project, we emphasize that our representatives will not act as supervisor of construction, nor will they direct construction operations. The various sub-contractors should be informed that neither the presence of our representatives nor the testing by our firm shall excuse them from defects discovered in their work. Job and site safety of the contractor's personnel will be the sole responsibility of the contractor.

Cost Proposal – Special Inspection Services – Shop Fabrication Only
SCCS SOQUEL HS INC 1 FITNESS ROOM MODERNIZATION
June 21, 2022

Page 2

Our agreement for this work is attached to this proposal. If this proposal is acceptable, please sign the agreement and return it to us as our written authorization to proceed. We will return a fully executed copy of the agreement to you for your files.

Please contact me with any questions or comments.

Wallace - Kuhl & Associates



David T. Hunn, PE
Senior Engineer
CE No. 67803, expires 6/30/23

Attachments: Construction Testing Agreement
2022P Fee Schedules



AGREEMENT FOR CONSTRUCTION TESTING SERVICES

THIS AGREEMENT, effective as of June 21, 2022, is by and between **Santa Cruz City Schools** ("Client") and **River City Geoprosessionals, Inc., dba Wallace-Kuhl and Associates** ("WKA").

THE PROJECT: **SCCS SOQUEL HS INC 1 FITNESS ROOM MODERNIZATION**

THE PROJECT is generally described as:

Provide shop fabrication special inspection services related to construction of a new shade structure.

THIS AGREEMENT consists of the following documents which are incorporated herein by reference:

- General Conditions for Construction Testing Services;
- **WKA's** Scope of Services Letter; and,
- **WKA's** Schedule of Fees (Exhibit A).

WKA agrees to perform the Services set forth in this Agreement and in accordance with its terms, including all attachments incorporated herein by reference. This Agreement may not be modified or altered, except in writing as specifically described in this Agreement.

	<u>CLIENT:</u>	<u>WKA:</u>
Signature:		_____
Print Name:	<u>Jimmy Montcal</u>	<u>David T. Hunn, PE</u>
Title:	<u>Asst Supt / Business</u>	<u>Senior Engineer</u>
Company:	<u>Santa Cruz City Schools</u>	<u>River City Geoprosessionals, Inc., dba Wallace-Kuhl and Associates (WKA)</u>
Address:	<u>133 Mission St #100</u>	<u>3050 Industrial Boulevard</u>
	<u>Santa Cruz, CA 95060</u>	<u>West Sacramento, CA 95691</u>
Date:	<u>06/22/22</u>	_____

GENERAL CONDITIONS FOR CONSTRUCTION TESTING SERVICES

1. DEFINITIONS

1.1. Contract Documents. Plans, specifications, and agreements between Client and Contractors, including addenda, amendments, supplementary instructions, and change orders.

1.2. Contractor. The contractor or contractors retained to construct the Project for which **Wallace-Kuhl and Associates (WKA)** is providing Services under this Agreement.

1.3. Day(s). Calendar day(s) unless otherwise stated.

1.4. Hazardous Materials. The term Hazardous Materials means any toxic substances, chemicals, radioactivity, pollutants or other materials, in whatever form or state, known or suspected to impair the environment in any way whatsoever. Hazardous Materials include, but are not limited to, those substances defined, designated or listed in any federal, state or local law, regulation or ordinance concerning hazardous wastes, toxic substances or pollution.

1.5. Services. The Services provided by **WKA** as set forth in this Agreement, the SCOPE OF SERVICES and any written amendment to this Agreement.

1.6. Work. The labor, materials, equipment and services required to complete the work described in the Contract Documents.

2. SCOPE OF SERVICES

WKA will perform the Services set forth in the attached SCOPE OF SERVICES.

2.1. Changes in Scope. If **WKA** provides Client with a writing confirming a change in the SCOPE OF SERVICES, it will become an amendment to this Agreement unless Client objects in writing within 5 business days after receipt. All Services performed by **WKA** on the Project are subject to the terms and limitations of this Agreement. If Services are performed, but the parties do not reach agreement concerning modifications to the SCOPE OF SERVICES or compensation, then the terms and limitations of this Agreement apply to such Services, except for the payment terms. The parties agree to resolve disputes concerning modifications to scope or compensation pursuant to Section 19, "Disputes."

2.2. Licenses. **WKA** will procure and maintain business and professional licenses and registrations necessary to provide its Services.

2.3. Excluded Services. **WKA's** Services under this Agreement include only those Services specified in the SCOPE OF SERVICES.

2.3.1. General. Client expressly waives any claim against **WKA** resulting from its failure to perform recommended additional Services that Client has not authorized **WKA** to perform, and any claim that **WKA** failed to perform services that Client instructs **WKA** not to perform.

2.3.2. Biological Pollutants. **WKA's** SCOPE OF SERVICES specifically excludes the investigation, detection, prevention or assessment of the presence of Biological Pollutants. The term "Biological Pollutants" includes, but is not limited to, molds, fungi, spores, bacteria, viruses, and/or any of their byproducts. **WKA's** SCOPE OF SERVICES will not include any interpretations, recommendations, findings, or conclusions pertaining to Biological Pollutants. Client agrees that **WKA** has no liability for any claims alleging a failure to investigate, detect, prevent, assess, or make recommendations for preventing, controlling, or abating Biological Pollutants. Furthermore, Client agrees to defend, indemnify, and hold harmless **WKA** from all claims by any third party concerning Biological Pollutants, except for damages caused by **WKA's** sole negligence.

3. PAYMENTS TO WKA

3.1. Basic Services. **WKA** will perform all Services set forth in the attached SCOPE OF SERVICES AND SCHEDULE OF FEES for the amount(s) set forth therein.

3.2. Additional Services. Any Services performed under this Agreement, except those Services expressly identified in the attached SCOPE OF SERVICES, will be provided on a time and materials basis unless otherwise specifically agreed to in writing by both parties.

3.3. Estimate of Fees. **WKA** will, to the best of its ability, perform the Services and accomplish the objectives defined in this Agreement within any written cost estimate provided by **WKA**. Client recognizes that changes in scope and schedule, and unforeseen circumstances can all influence the successful completion of Services within the estimated cost. The use of an estimate of fees or of a "not to exceed" limitation is not a guarantee that the Services will be completed for that amount; rather, it indicates that **WKA** shall not incur fees and expenses in excess of the estimate or limitation amount without obtaining Client's agreement to do so.

3.4. Rates. Client will pay **WKA** at the rates set forth in the attached SCHEDULE OF FEES.

3.4.1. Changes to Rates. Client and **WKA** agree that the SCHEDULE OF FEES is subject to periodic review and amendment, as appropriate to reflect **WKA's** then-current fee structure. **WKA** will give Client at least 30 days advance notice of any changes. Unless Client objects in



writing to the proposed amended fee structure within 30 days of notification, the amended fee structure will be incorporated into this Agreement and will then supersede any prior fee structure. If Client timely objects to the amended fee structure, and **WKA** and Client cannot agree upon a new fee structure within 30 days after notice, **WKA** may terminate this Agreement and be compensated as set forth under Section 18, "Termination."

3.4.2. Prevailing Wages. Unless Client specifically informs **WKA** in writing that prevailing wage regulations cover the Project and the SCOPE OF SERVICES identifies it as covered by such regulations, Client will reimburse, defend, indemnify and hold harmless **WKA** from and against any liability resulting from a subsequent determination that prevailing wage regulations cover the Project, including all costs, fines and attorneys' fees.

3.5. Payment Timing; Late Charge. All invoices are due upon receipt. All amounts unpaid 30 days after the invoice date will include a late payment charge from the date of the invoice, at the rate of 1-1/2% per month or the highest rate permitted by law. If the Client is an LLC or LLP, the person signing this agreement shall be personally responsible for payment of all invoices and late fees.

4. STANDARD OF PERFORMANCE; DISCLAIMER OF WARRANTIES

4.1. Level of Service. **WKA** offers different levels of Geotechnical and Environmental Engineering and Construction Testing Services to suit the desires and needs of different clients. Although the possibility of error can never be eliminated, more detailed and extensive Services yield more information and reduce the probability of error, but at increased cost. Client must determine the level of Services adequate for its purposes. Client has reviewed the SCOPE OF SERVICES and has determined that it does not need or want a greater level of Services than that being provided.

4.2. Standard of Care. Subject to the limitations inherent in the agreed SCOPE OF SERVICES as to the degree of care, the amount of time and expenses to be incurred, and subject to any other limitations contained in this Agreement, **WKA** will perform its Services consistent with that level of care and skill ordinarily exercised by other professional engineers practicing in the same locale and under similar circumstances at the time the Services are performed.

4.3. No Warranty. No warranty, either express or implied, is included or intended by this Agreement.

5. ESTIMATE OF CONSTRUCTION COSTS

Client acknowledges that construction and Project development are subject to many influences that are not subject to precise forecasting and are outside of **WKA's** control. Client further acknowledges that actual costs incurred may vary substantially from the estimates

prepared by **WKA** and that **WKA** does not warrant or guaranty the accuracy of construction or development cost estimates.

6. CONSTRUCTION PHASE SERVICES

If **WKA's** SCOPE OF SERVICES includes observation and/or testing during the course of construction, **WKA** may:

6.1. Construction Observation.

6.1.1. Site Meetings & Visits. **WKA** will participate in job site meetings as requested by Client or Client's designated representative, and, unless otherwise requested by Client, visit the site at times specified in the SCOPE OF SERVICES or, if not specified in the SCOPE OF SERVICES, at intervals as **WKA** deems appropriate to observe the geotechnical conditions encountered by Contractor and the progress and quality of the geotechnical aspects of the Work. Based on information obtained during such visits and on such observations, **WKA** may inform Client of the progress of the geotechnical aspects of the Work. Client understands that **WKA** may not be on site continuously; and, unless expressly agreed otherwise, **WKA** will not observe all of the Work.

6.1.2. Contractor's Performance. **WKA** does not, and cannot, warrant or guarantee that all of the geotechnical Work performed by Contractor meets the requirements of **WKA's** geotechnical recommendations or the plans and specifications for such geotechnical Work; nor can **WKA** be responsible for Contractor's failure to perform the Work in accordance with the plans, specifications or the recommendations of **WKA**.

6.1.3. Contractor's Responsibilities. **WKA** will not supervise, direct or have control over the Work nor will **WKA** have authority over or responsibility for the means, methods, techniques, sequences or procedures of construction selected by Contractor for the geotechnical aspects of the Project; for safety precautions and programs incident to the Work; nor for any failure of Contractor to comply with Laws and Regulations applicable to Contractor furnishing and performing its Work.

6.1.4. Final Report. At the conclusion of Construction Phase Services, **WKA** will provide Client with a written report summarizing the tests and observations, if any, made by **WKA**.

6.2. Review of Contractor's Submittals. If included in the SCOPE OF WORK, **WKA** will review and take appropriate action on the Contractor's submittals, such as shop drawings, product data, samples, and other required submittals. **WKA** will review such submittals solely for general conformance with **WKA's** design, and will not include review for the following, all of which will remain the responsibility of the Contractor: accuracy or completeness of details, quantities or dimensions; construction means, methods, sequences or procedures; coordination among trades; or construction safety.



6.3. Tests. Tests performed by **WKA** on finished Work or Work in progress are taken intermittently and indicate the general acceptability of the Work on a statistical basis. **WKA's** tests and observations of the Work are not a guarantee of the quality of Work and do not relieve other parties from their responsibility to perform their Work in accordance with applicable plans, specifications and requirements.

7. CLIENT'S RESPONSIBILITIES

In addition to payment for the Services performed under this Agreement, Client agrees to:

7.1. Cooperation. Assist and cooperate with **WKA** in any manner necessary and within its ability to facilitate **WKA's** performance under this Agreement.

7.2. Representative. Designate a representative with authority to receive all notices and information pertaining to this Agreement, communicate Client's policies and decisions, and assist as necessary in matters pertaining to the Project and this Agreement. Client's representative will be subject to change by written notice.

7.3. Rights of Entry. Provide access to and/or obtain permission for **WKA** to enter upon all property, whether or not owned by Client, as required to perform and complete the Services. **WKA** will operate with reasonable care to minimize damage to the Project Site(s). However, Client recognizes that **WKA's** operations and the use of investigative equipment may unavoidably alter conditions or affect the environment at the existing Project Site(s). The cost of repairing such damage will be borne by Client and is not included in the fee unless otherwise stated.

7.4. Relevant Information. Supply **WKA** with all information and documents in Client's possession or knowledge which are relevant to **WKA's** Services. Client warrants the accuracy of any information supplied by it to **WKA** and acknowledges that **WKA** is entitled to rely upon such information without verifying its accuracy. Prior to the commencement of any Services in connection with a specific property, Client will notify **WKA** of any known potential or possible health or safety hazard existing on or near the Project Site, with particular reference to Hazardous Materials or conditions.

7.5. Subsurface Structures. Correctly designate on plans to be furnished to **WKA**, the location of all subsurface structures, such as pipes, tanks, cables and utilities within the property lines of the Project Site(s) and be responsible for any damage inadvertently caused by **WKA** to any such structure or utility not so designated. **WKA** is not liable to Client for any losses, damages or claims arising from damage to subterranean structures or utilities that were not correctly shown on plans furnished by Client to **WKA**.

8. CHANGED CONDITIONS

If **WKA** discovers conditions or circumstances that it had not contemplated at the commencement of this

Agreement ("Changed Conditions"), **WKA** will notify Client in writing of the Changed Conditions. Client and **WKA** agree to that they will then renegotiate in good faith the terms and conditions of this Agreement. If **WKA** and Client cannot agree upon amended terms and conditions within 30 days after notice, **WKA** may terminate this Agreement and be compensated as set forth in Section 18, "Termination."

9. HAZARDOUS MATERIALS

Client understands that **WKA's** Services under this Agreement are limited to geotechnical or environmental engineering and construction testing services and that **WKA** has no responsibility to locate, identify, evaluate, treat or otherwise consider or deal with Hazardous Materials. Client is solely responsible for notifying all appropriate federal, state, municipal or other governmental agencies, including the potentially affected public, of the existence of any Hazardous Materials located on or in the Project site, or located during the performance of this Agreement. The existence or discovery of Hazardous Materials constitutes a Changed Condition under this Agreement.

10. CERTIFICATIONS

Client agrees not to require that **WKA** execute any certification with regard to Services performed or Work tested and/or observed under this Agreement unless: 1) **WKA** believes that it has performed sufficient Services to provide a sufficient basis to issue the certification; 2) **WKA** believes that the Services performed or Work tested and/or observed meet the criteria of the certification; and 3) **WKA** has reviewed and approved in writing the exact form of such certification prior to execution of this Agreement. Any certification by **WKA** is limited to an expression of professional opinion based upon the Services performed by **WKA**, and does not constitute a warranty or guaranty, either express or implied.

11. ALLOCATION OF RISK

11.1. Limitation of Liability. The total cumulative liability of **WKA**, its subconsultants and subcontractors, and all of their respective shareholders, directors, officers, employees and agents (collectively "**WKA Entities**"), to Client arising from Services under this Agreement, including attorney's fees due under this Agreement, will not exceed the gross compensation received by **WKA** under this Agreement or \$50,000, whichever is greater; provided, however, that such liability is further limited as described below. This limitation applies to all lawsuits, claims or actions that allege errors or omissions in **WKA's** Services, whether alleged to arise in tort, contract, warranty, or other legal theory. Upon Client's written request, **WKA** and Client may agree to increase the limitation to a greater amount in exchange for a negotiated increase in **WKA's** fee, provided that they amend this Agreement in writing as provided in Section 20.



11.2. Indemnification.

11.2.1. *Indemnification of Client.* Subject to the provisions and limitations of this Agreement, **WKA** agrees to indemnify and hold harmless Client, its shareholders, officers, directors, and employees from and against any and all claims, suits, liabilities, damages, expenses (including reasonable attorney's fees and costs of defense), or other losses (collectively "Losses") to the extent caused by **WKA's** negligent performance of its Services under this Agreement and proportionate the degree of fault of **WKA**. Notwithstanding the foregoing, **WKA** has no immediate obligation to provide the defense of any indemnified party for claims, suits, liabilities, damages, expenses alleged to have been caused by the negligent performance of professional services performed by **WKA**. **WKA** agrees to reimburse indemnified parties their reasonable cost of defense ultimately determined by an arbiter or Court of competent jurisdiction to have been caused by **WKA's** negligent performance of professional services and proportionate to **WKA's** fault.

11.2.2. *Indemnification of WKA.* Client will indemnify and hold harmless **WKA Entities** from and against any and all Losses to the extent caused by the negligence of Client, its employees, agents and contractors. In addition, except to the extent caused by **WKA's** sole negligence, Client expressly agrees to defend, indemnify and hold harmless **WKA Entities** from and against any and all Losses arising from or related to the existence, disposal, release, discharge, treatment or transportation of Hazardous Materials, or the exposure of any person to Hazardous Materials, or the degradation of the environment due to the presence, discharge, disposal, release of or exposure to Hazardous Material.

11.3. *Consequential Damages.* Neither Client nor **WKA** will be liable to the other for any special, consequential, incidental or penal losses or damages including but not limited to losses, damages or claims related to the unavailability of property or facilities, shutdowns or service interruptions, loss of use, profits, revenue, or inventory, or for use charges, cost of capital, or claims of the other party and/or its customers.

11.4. *Continuing Agreement.* The indemnity obligations and the limitations of liability established under this Agreement will survive the expiration or termination of this Agreement. If **WKA** provides Services to Client that the parties do not confirm through execution of an amendment to this Agreement, the obligations of the parties to indemnify each other and the limitations on liability established under this Agreement apply to such Services as if the parties had executed an amendment.

12. INSURANCE

12.1. *WKA's Insurance.* **WKA** will obtain, if reasonably available, the following coverages:

12.1.1. *Statutory Workers' Compensation/Employer's Liability Insurance;*

12.1.2. *Commercial General Liability Insurance* with a combined single limit of \$1,000,000 per occurrence and \$2,000,000 annual aggregate;

12.1.3. *Automobile Liability Insurance*, including liability for all owned, hired and non-owned vehicles with minimum limits of \$1,000,000 for bodily injury per person, \$1,000,000 property damage, and \$1,000,000 combined single limit per occurrence; and,

12.1.4. *Professional Liability Insurance* in amounts of \$2,000,000 per claim and annual aggregate.

12.2. *Contractor's Insurance.* Client shall require that all Contractors and subcontractors for the Project name **WKA** as an additional insured under their General Liability and Automobile Liability insurance policies. If Client is not the Project owner, Client will require the Project owner to require the owner's Contractor to purchase and maintain General Liability, Builder's Risk, Automobile Liability, Workers' Compensation, and Employer's Liability insurance with limits no less than as set forth above, and to name **WKA** and its subcontractors and subconsultants as additional insureds on the General Liability insurance.

12.3. *Certificates of Insurance.* Upon request, **WKA** and Client will each provide the other with certificate(s) of insurance evidencing the existence of the policies required herein. Except for Professional Liability and Workers' Compensation Insurance, all policies required herein shall contain a waiver of subrogation.

13. OWNERSHIP AND USE OF DOCUMENTS

13.1. *Client Documents.* All documents provided by Client will remain the property of Client. **WKA** will return all such documents to Client upon request but may retain file copies of such documents.

13.2. *WKA's Documents.* Unless otherwise agreed in writing, all documents and information prepared by **WKA** or obtained by **WKA** from any third party in connection with the performance of Services, including, but not limited to, **WKA's** reports, boring logs, maps, field data, field notes, drawings and specifications, laboratory test data and other similar documents (collectively "Documents") are the property of **WKA**. **WKA** has the right, in its sole discretion, to dispose of or retain the Documents.

13.3. *Use of Documents.* All Documents prepared by **WKA** are solely for use by Client and will not be provided by either party to any other person or entity without **WKA's** prior written consent.

13.3.1. *Use by Client.* Client has the right to reuse the Documents for purposes reasonably connected with the Project for which the Services are provided, including without limitation design and licensing requirements of the Project.

13.3.2. *Use by WKA.* **WKA** retains the right of ownership with respect to any patentable concepts or



copyrightable materials arising from its Services and the right to use the Documents for any purpose.

13.4. Electronic Media. WKA may agree at Client's request to provide Documents and information in an electronic format. Client recognizes that Documents or other information recorded on or transmitted as electronic media are subject to undetectable alteration due to (among other causes) transmission, conversion, media degradation, software error, or human alteration. Accordingly, all Documents and information provided by WKA in electronic media are for informational purposes only and not as final documentation. Unless otherwise defined in the Scope of Services, WKA's electronic Documents and media will conform to WKA's standards. WKA will provide any requested electronic Documents for a 30-day acceptance period, and WKA will correct any defects reported by Client to WKA during this period. WKA makes no warranties, either express or implied, regarding the fitness or suitability of any electronic Documents or media.

13.5. Unauthorized Reuse. No party other than Client may rely, and Client will not represent to any other party that it may rely on Documents without WKA's express prior written consent and receipt of additional compensation. Client will not permit disclosure, mention, or communication of, or reference to the Documents in any offering circular, securities offering, loan application, real estate sales documentation, or similar promotional material without WKA's express prior written consent. Client waives any and all claims against WKA resulting in any way from the unauthorized reuse or alteration of Documents by itself or anyone obtaining them through Client. Client will defend, indemnify and hold harmless WKA from and against any claim, action or proceeding brought by any party claiming to rely upon information or opinions contained Documents provided to such person or entity, published, disclosed or referred to without WKA's prior written consent.

14. SAMPLES AND CUTTINGS

14.1. Sample Retention. If WKA provides laboratory testing or analytic Services, WKA will preserve such soil, rock, water, or other samples as it deems necessary for the Project, but no longer than 45 days after issuance of any Documents that include the data obtained from these samples. Client will promptly pay and be responsible for the removal and lawful disposal of all contaminated samples, cuttings, Hazardous Materials, and other hazardous substances.

14.2. Monitoring Wells. Client will take custody of all monitoring wells and probes installed during any investigation by WKA and will take any and all necessary steps for the proper maintenance, repair or closure of such wells or probes at Client's expense.

15. RELATIONSHIP OF THE PARTIES

WKA will perform Services under this Agreement as an independent contractor.

16. ASSIGNMENT AND SUBCONTRACTS

Neither party may assign this Agreement, in whole or in part, without the prior written consent of the other party, except for an assignment of proceeds for financing purposes. WKA may subcontract for the services of others without obtaining Client's consent if WKA deems it necessary or desirable for others to perform certain Services.

17. SUSPENSION AND DELAYS

17.1. Procedures. Client may, at any time by 10 days written notice suspend performance of all or any part of the Services by WKA. WKA may terminate this Agreement if Client suspends WKA's Services for more than 60 days and Client will pay WKA as set forth under Section 18, "Termination." If Client suspends WKA's Services, or if Client or others delay WKA's Services, Client and WKA agree to equitably adjust: (1) the time for completion of the Services; and (2) WKA's compensation in accordance with WKA's then current SCHEDULE OF FEES for the additional labor, equipment, and other charges associated with maintaining its workforce for Client's benefit during the delay or suspension, or charges incurred by WKA for demobilization and subsequent remobilization.

17.2. Liability. WKA is not liable to Client for any failure to perform or delay in performance due to circumstances beyond WKA's control, including but not limited to pollution, contamination, or release of hazardous substances, strikes, lockouts, riots, wars, fires, flood, explosion, pandemics, epidemics, adverse weather conditions, acts of government, labor disputes, delays in transportation or inability to obtain material and equipment in the open market.

18. TERMINATION

18.1. Termination for Convenience. WKA and Client may terminate this Agreement for convenience upon 30 days written notice delivered or mailed to the other party.

18.2. Termination for Cause. In the event of material breach of this Agreement, the party not breaching the Agreement may terminate it upon 10 days written notice delivered or mailed to the other party. The termination notice shall state the basis for the termination. The Agreement may not be terminated for cause if the breaching party cures the breach within the 10-day period.

18.3. Payment on Termination. Following termination other than for WKA's material breach of this Agreement, Client will pay WKA for Services performed prior to the termination notice date, and for any necessary Services and expenses incurred in connection with the termination of the Project, including but not limited to, the costs of



completing analysis, records and reports necessary to document job status at the time of termination and costs associated with termination of subcontractor contracts in accordance with **WKA's** then current SCHEDULE OF FEES.

19. DISPUTES

19.1. Mediation. All disputes between **WKA** and Client are subject to mediation. Either party may demand mediation by serving a written notice stating the essential nature of the dispute, amount of time or money claimed, and requiring that the matter be mediated within 45 days of service of notice.

19.2. Precondition to Other Action. No action or suit may be commenced unless the mediation did not occur within 45 days after service of notice; or the mediation occurred but did not resolve the dispute; or a statute of limitation would elapse if suit was not filed prior to 45 days after service of notice.

19.3. Choice of Law; Venue. This Agreement will be construed in accordance with and governed by the laws of the State of California. Unless the parties agree otherwise, any mediation or other legal proceeding will occur in the state and county in which the Project is located.

19.4. Statutes of Limitations. Any applicable statute of limitations will be deemed to commence running on the earlier of the date of substantial completion of **WKA's** Services under this Agreement or the date on which claimant knew, or should have known, of facts giving rise to its claims.

20. MISCELLANEOUS

20.1. Integration and Severability. This Agreement reflects the entire agreement of the parties with respect to its terms and supersedes all prior agreements, whether written or oral. If any portion of this Agreement is void or voidable, such portion will be deemed stricken and the Agreement reformed to as closely approximate the stricken portions as the law allows.

20.2. Modification of this Agreement. This Agreement may not be modified or altered, except by a written agreement signed by authorized representatives of both parties and referring specifically to this Agreement.

20.3. Notices. Any and all notices, requests, instructions, or other communications given by either party to the other must be in writing and either hand delivered to the recipient or delivered by first-class mail (postage prepaid) or express mail (billed to sender) at the addresses given in this Agreement.

20.4. Headings. The headings used in this Agreement are for convenience only and are not a part of this Agreement.

20.5. Waiver. The waiver of any term, conditions or breach of this Agreement will not operate as a subsequent waiver of the same term, condition, or breach.

End of General Conditions



EXHIBIT A
WKA Schedule of Fees



PROFESSIONAL SERVICES

PROFESSIONAL SERVICES

Principal Engineer / Geologist	\$ 210.00	per hour
Senior Engineer / Geologist	\$ 205.00	per hour
Senior Environmental Scientist	\$ 205.00	per hour
Project Engineer / Geologist	\$ 170.00	per hour
Project Environmental Scientist	\$ 170.00	per hour
Senior Staff Engineer / Geologist	\$ 160.00	per hour
Senior Staff Environmental Scientist	\$ 160.00	per hour
Staff Engineer / Geologist	\$ 150.00	per hour
Staff Environmental Scientist	\$ 150.00	per hour
Senior Environmental Technician	\$ 125.00	per hour
Senior / Supervising Technician	\$ 125.00	per hour
Draftsperson / GIS Technician	\$ 120.00	per hour
Administrative Assistant	\$ 90.00	per hour

FIELD INVESTIGATION TESTING

Seismic Refraction Survey	\$ 205.00	per hour
Thermal Resistivity Testing	\$ 205.00	per hour
Electrical Resistivity Survey	\$ 205.00	per hour
Hand Augering/Sampling - Engineer	\$ 180.00	per hour
Photoionization Detector	\$ 210.00	per hour
Rebar Location / GPR	\$ 335.00	per hour

LITIGATION

Data Review/Consultation	\$310.00	per hour
Depositions/Expert Witness Testimony	\$425.00	per hour

EXPENSES

Vehicle Charges (<i>Subject to periodic adjustment due to fuel cost</i>)	\$0.75	per mile
Subsistence	\$90.00	per day
Lodging	Cost	
Services by Associate Firms and other outside services	Cost	plus 20%
Equipment rental, freight, special materials	Cost	plus 20%
Extra Report Copies		
Black and white versions	\$35.00	each
Color photography versions	\$45.00	each

PREMIUM CHARGES

Overtime and Saturdays	hourly rate plus	40	percent
Sunday and Holidays, and over 8 hrs on Saturday	hourly rate plus	75	percent

SHIFT DIFFERENTIAL

A 25 percent shift differential surcharge will be added to the hourly rate of personnel involved in scheduled testing work between the hours of 6 P.M. and 5 A.M., as well as a four hour minimum.



FIELD SERVICES

CONCRETE & REINFORCING STEEL

Ball Penetration (Kelly Ball)	\$150.00 /hr.
Batch Plant Inspection	\$120.00 /hr.
CaCl Moisture Emission Test Kit	\$40.00 /kit
CaCl Moisture Emission Testing	\$115.00 /hr.
CLSM/CDF/Slurry Testing	\$115.00 /hr.
Concrete Mix Design Review	\$205.00 /hr.
Concrete Placement Obs/Cast Cylinder	\$120.00 /hr.
Concrete Rebound Number Testing	\$150.00 /hr.
Concrete Trial Batch	\$120.00 /hr.
Floor Flatness Testing	\$150.00 /hr.
High Strength Grout Sampling / Testing	\$120.00 /hr.
Rebar / Post Tension Special Inspection	\$130.00 /hr.
Rebar Location / GPR	\$340.00 /hr.
Rebar Location / Pachometer	\$150.00 /hr.
Rebar Placement Inspection	\$130.00 /hr.
Reinforcing Steel Sampling/Tagging	\$120.00 /hr.
Relative Humidity Testing	\$150.00 /hr.
Shotcrete Special Inspection	\$120.00 /hr.
Transport Cylinders / Samples to Lab	\$120.00 /hr.

CORING

Coring (Technician + equipment)	\$150.00 /hr.
Coring (Technician assistant)	\$120.00 /hr.

POST-INSTALLED ANCHORS

Concrete Anchor Installation Inspection	\$120.00 /hr.
Concrete Anchor Proof Load Testing	\$150.00 /hr.
Concrete Anchor Torque Testing	\$130.00 /hr.
Suspended Ceiling Inspection / Testing	\$150.00 /hr.

STRUCTURAL STEEL

Fireproofing Special Inspection / Testing	\$120.00 /hr.
High Strength Bolt Skidmore Testing	\$150.00 /hr.
High Strength Bolt Special Inspection	\$130.00 /hr.
Material Identification	\$130.00 /hr.
Non-Destructive Testing - UT/MT/PT	\$150.00 /hr.
Tower Certified Special Inspector	\$150.00 /hr.
Welding Special Inspection - Field	\$130.00 /hr.
Welding Special Inspection - Shop	\$120.00 /hr.

MASONRY

In-Place Masonry Flatjack Testing	\$185.00 /hr.
In-Place Masonry Shear Testing	\$150.00 /hr.
Masonry Materials Sampling / Testing	\$120.00 /hr.
Masonry Special Inspection	\$120.00 /hr.
Masonry Special Inspection DSA Cert.	\$135.00 /hr.

SOILS & ASPHALT CONCRETE

Asphalt Concrete Inspection / Testing	\$130.00 /hr.
Asphalt Concrete Materials Sampling	\$130.00 /hr.
Building Pad Special Inspection / Testing	\$130.00 /hr.
Deep Foundation Inspection	\$130.00 /hr.
Flatwork AB Inspection / Testing	\$130.00 /hr.
Flatwork Subgrade Inspection / Testing	\$130.00 /hr.
Grading Inspection / Testing	\$130.00 /hr.
Hand Augering and Sampling	\$130.00 /hr.
Pavement AB Inspection / Testing	\$130.00 /hr.
Pavement Subgrade Inspection / Testing	\$130.00 /hr.
Proof Rolling Observation	\$130.00 /hr.
Shallow Foundation Inspection	\$130.00 /hr.
Slab Subgrade Soil Moisture Tests	\$130.00 /hr.
Soil / Aggregate Sampling	\$130.00 /hr.
Soil Treatment Testing / Observation	\$130.00 /hr.
Structure Backfill Inspection / Testing	\$130.00 /hr.
Subgrade Stabilization Observation	\$130.00 /hr.
Utility Trench Backfill Testing	\$130.00 /hr.
WKA Drill Rig (including operator)	\$255.00 /hr.
WKA Drill Rig (helper)	\$130.00 /hr.

SPECIALIZED SERVICES

Coefficient of Friction Testing	\$160.00 /hr.
Crack Monitoring	**
Epoxy / FRP Installation Inspection	\$120.00 /hr.
Existing Building Evaluation / Demo	\$120.00 /hr.
Existing Building Evaluation / Document	\$120.00 /hr.
Existing Building Evaluation / Repair	\$120.00 /hr.
Field Investigate Support	\$120.00 /hr.
Firestopping Inspection	\$135.00 /hr.
GFRC Inspection / Testing	\$120.00 /hr.
Glulam / Truss Fabrication Inspection	\$130.00 /hr.
Glulam / Truss Inspection Travel	\$95.00 /hr.
Meggar Ground Testing	\$150.00 /hr.
Prestress Framing Installation	\$120.00 /hr.
Proto Wall Inspection / Testing	\$120.00 /hr.
Roofing Inspection	\$120.00 /hr.
Shear Nailing Inspection	\$120.00 /hr.
Soil Elect. Resitivity Testing - Technician	\$160.00 /hr.
Thickness Testing - Coating / Steel	\$150.00 /hr.
Timber Framing / Hardware Inspection	\$120.00 /hr.
Timber-in-Structure Inspection	\$150.00 /hr.
Vapor Barrier Inspection	\$120.00 /hr.
Vibration Monitoring	**

GENERAL

Inspection / Testing Cancelled	*
Reinspection / Retesting	*
Stand-by Time	*

* Based on hourly rate of Inspection or Testing scheduled

** Based on Staff Classification

MINIMUM CHARGES

A two hour minimum charge will apply to field technician services with the following exceptions:

- a) Single trip pickup and delivery services, where a one hour minimum will apply.
- b) Saturday, Sunday and holidays, where a four hour minimum charge will apply.



LABORATORY SERVICES

SOIL			
Atterberg Limits (LL/PI) - Wet Method	ASTM D4318	\$175.00	each
CLSM/CDF/Soil Cement Compression Test	ASTM D4832	\$65.00	each
Compaction Characteristics	ASTM D698	\$285.00	each
Compaction Characteristics	ASTM D1557	\$285.00	each
Compaction Characteristics	CTM 216	\$285.00	each
Consolidation (8 loads + 1 rebound)	ASTM D2435	\$525.00	each
Consolidation (additional loads)	ASTM D2435	\$85.00	each
Expansion Index	ASTM D4829	\$210.00	each
Hydraulic Conductivity, Flexible Wall Permeability	ASTM D5084	\$440.00	each
Lime-Treated Unconfined Compression	CTM 373	\$840.00	each
Moisture Content	ASTM D2216	\$45.00	each
Organic Content	ASTM D2974	\$110.00	each
Particle-Size Distribution - Hydrometer	ASTM D7928	\$180.00	each
Particle-Size Distribution - Sieve Analysis	ASTM D6913	\$120.00	each
Resistance "R" Value - Laboratory Lime-Treated	ASTM D2844, CTM 301	\$340.00	each
Resistance "R" Value - Untreated	ASTM D2844, CTM 301	\$290.00	each
Sieve Analysis - Passing No. 200 only	ASTM D1140	\$105.00	each
Specific Gravity of Soils	ASTM D854	\$150.00	each
Thermal Resistivity	ASTM D5334	\$85.00	each
Triaxial Compression Test, 1 point - Remolded	ASTM D4767	\$355.00	each
Triaxial Compression Test, 1 point - Undisturbed	ASTM D4767	\$275.00	each
Triaxial Compression Test, 3 Pt. Staged - Remolded	ASTM D4767	\$435.00	each
Triaxial Compression Test, 3 Pt. Staged - Undisturbed	ASTM D4767	\$335.00	each
Unconfined Compression Test	ASTM D2166	\$120.00	each
Unit Weight/Moisture Content - Tube Sample	ASTM D2937/D2216	\$45.00	each
AGGREGATE			
Aggregate Unit Weight	ASTM C29	\$65.00	each
Clay Lumps and Friable Particles	ASTM C142	\$170.00	per size
Cleanness Value	CTM 227	\$180.00	each
Correction of Unit Weight & Water Content for Oversize Particles	ASTM D4718	\$125.00	each
Durability Index (Coarse or Fine)	CTM 229	\$180.00	each
Flat and Elongated Particles in Coarse Aggregate	ASTM D4791	\$130.00	per size
Fractured/Crushed Particles	ASTM D5821, CTM 205, AASHTO T335	\$130.00	per size
Organic Impurities in Fine Aggregates	ASTM C40	\$70.00	each
Resistance "R" Value - Aggregate	CTM 301	\$330.00	each
Sand Equivalent, 1 point	CTM 217, AASHTO T176	\$115.00	each
Sand Equivalent, 3 points	CTM 217, AASHTO T176	\$150.00	each
Sieve Analysis - Coarse or Fine	ASTM C136, CTM 202, AASHTO T27	\$125.00	each
Sieve Analysis - Passing No. 200 only	ASTM C117, AASHTO T11	\$105.00	each
Sodium Sulfate Soundness	ASTM C88, CTM 214	\$180.00	per size
Specific Gravity and Absorption (Coarse or Fine)	ASTM C127, C128	\$135.00	each
ASPHALT CONCRETE			
Asphalt Content (Ignition Oven)	CTM 382, AASHTO T308	\$280.00	each
Asphalt Content Correction Factor Development	CTM 382, AASHTO T308	\$550.00	each
Hveem Compaction, Unit Weight, and Stability	ASTM D1560/D2726		
	CTM 304/308, AASHTO T166	\$360.00	set of 3
Laboratory Test Maximum Density (LTMD), 5 points	CTM 375	\$380.00	each
Moisture Content of Asphalt Mixtures	CTM 370, AASHTO T329	\$85.00	each
Sieve Analysis of AC Aggregate (Coarse and Fine)	ASTM D5444, CTM 202, AASHTO T30	\$190.00	each



LABORATORY SERVICES

ASPHALT CONCRETE (continued)

Theoretical Maximum Density	ASTM D2041, CTM 309, AASHTO T209	\$175.00	each
Thickness of AC Cores	ASTM D3549	\$30.00	each
Unit Weight of AC Cores	CTM 308, AASHTO T166/T275	\$70.00	each

CONCRETE

Compression Test, Concrete Cylinder	ASTM C39	\$30.00	each
Compression Test, Concrete Cylinder - Hold	ASTM C39	\$27.00	each
Compression Test, Concrete Core	ASTM C42, C39	\$85.00	each
Compression Test, Shotcrete Core	ASTM C42, C39	\$115.00	each
Compression Test, High Strength Grout	ASTM C1107/C109	\$45.00	each
Concrete Cylinder Mold		\$7.00	each
Density / Unit Weight of Concrete	ASTM C567, C642	\$110.00	each
Flexural Strength Test, Concrete Beam	ASTM C78	\$125.00	each
Laboratory Drying Shrinkage Test, per beam	ASTM C157, AASHTO T160	\$225.00	each
Splitting Tensile Test, Concrete Cylinder	ASTM C496	\$90.00	each

MASONRY

Brick			
Compression Test	ASTM C67	\$80.00	each
Modulus of Rupture	ASTM C67	\$85.00	each
Absorption	ASTM C67	\$100.00	each
Concrete Masonry Unit			
Compression Test	ASTM C140	\$95.00	each
Absorption & Moisture Content	ASTM C140	\$95.00	each
Linear Drying Shrinkage	ASTM C426	\$235.00	each
Compression Test, Composite Masonry Prism	ASTM C1314	\$160.00	each
Compression Test, Masonry Grout	ASTM C1019	\$50.00	each
Compression Test, Mortar	ASTM C780/C109	\$45.00	each
Core Shear Test	CBC Section 2105A	\$100.00	each

STEEL

Anchor Bolt Tensile Test	ASTM F606	\$120.00	each
Fireproofing Density Test	ASTM E605	\$105.00	each
High Strength Bolt Assembly Laboratory Testing			
Bolt - Wedge Tension Test	ASTM F606	\$95.00	each
Bolt - Proof Load Test	ASTM F606	\$95.00	each
Bolt - Hardness Test	ASTM E18	\$45.00	each
Nut - Proof Load Test	ASTM F606	\$95.00	each
Nut - Hardness Test	ASTM E18	\$45.00	each
Washer - Hardness Test	ASTM E18	\$45.00	each
Prestressing Steel Strand Tensile Test	ASTM A416/A1061	\$420.00	each
Reinforcing Steel (Rebar) Tensile Test			
Up to No. 7	ASTM A615, A706/A370	\$100.00	each
From No. 8 through No. 14	ASTM A615, A706/A370	\$130.00	each
Reinforcing Steel (Rebar) Bend Test	ASTM A615, A706/A370	\$55.00	each
Structural Steel Tensile Test			
Up to 3/4"	ASTM A370	\$115.00	each
Sizes Larger Than 3/4"	ASTM A370	\$125.00	each
Machining of Test Specimens		cost plus 20%	
Structural Steel Hardness Test	ASTM E18	\$90.00	each
Weld Assembly, Guided Bend/Macroetch/T-Bend Test	AWS D1.1, ASTM E190	\$90.00	per test
Welder Qualification Test Inspection		\$110.00	per hour
Welder Qualification Test Record		\$105.00	each

TESTING SERVICES

Laboratory Technician		\$105.00	per hour
-----------------------	--	----------	----------



SANTA CRUZ CITY SCHOOL DISTRICT

AGENDA ITEM: Staff Report: Summer School Report

MEETING DATE: August 17, 2022

FROM: Dorothy Coito, Assistant Superintendent of Educational Services

THROUGH: Kris Munro, Superintendent

BACKGROUND:

Santa Cruz City Schools continues to provide a rich and robust summer school program for all three grade spans: Elementary, Middle, & High. Each program aimed to support students with learning in a positive, relevant, and fun environment.

End of school year assessment data as well as secondary grade data was used to determine strategic focus areas for each summer school program. Summer school teachers and principals worked collaboratively to develop the focus, curriculum, and strategies used to engage students in learning.

Elementary Summer School

Number of students served: 235

Staff:

- 11 teachers
- One principal
- One after school programs coordinators
- One admin assistant
- One social emotional counselor (shared with secondary)
- Eight paraeducators

Program Purpose and Goals:

- Students were invited to summer school based on achievement data collected during the school year. Priority was given to students who were two or more grade levels below in math or reading on iReady or two grade levels behind on the Fountas and Pinnell reading assessment.
- The elementary summer program met the state of California's new Extended Learning Opportunity Program (ELOP) requirements for summer programming. These requirements are:
 - 30 days of learning
 - 9 hours of programming each day
 - Targeted to unduplicated students
 - Enrichment opportunities for students

AGENDA ITEM: 8.5.1.1.

Math: The curriculum for summer school was *iReady myPath*. Students in summer school had already been using the digital component as an intervention tool during the school year. *myPath* provides students instruction and practice at their instructional level so that skills can be boosted. A typical math block was 90 min and involved teacher-led lessons on priority standards from the previous school year, digital practice in *myPath*, and math games to improve fluency.

Literacy: All staff used the *Benchmark Workshop* summer intervention curriculum to support their instruction. The summer curriculum was designed to be delivered as an intervention and focused on priority standards and learning from the prior year. During the literacy block, teachers held guided reading groups, did phonics practice, and used *Lexia* for independent student practice.

Passion Project: Each teacher also spent 30-45 minutes a day on a long-term project of their own creation that was a personal passion. One class studied bridges and engineering models and culminated the year with an egg drop to test the effectiveness of their egg carriers. Another class studied the history of pinatas and finished the summer making beautiful pinatas. All the projects incorporated fun with more opportunities to boost student literacy and math skills.

After School Enrichment Camp: Students could stay on campus until 5:30 PM if needed. The after-school enrichment camp staff provided fun, “summer camp” opportunities for students. Students went to Happy Hollow in San Jose, the beach, the park, Harvey west pool, and stayed on site to play games, do arts and crafts, and be with friends.

Program Strengths, Successes:

- Instruction was very targeted toward the needs of the students, and all students were ready to learn and be a participant in their classes.
- Benchmark summer curriculum was a great support to first year teachers in giving quality instruction to students.
- The emphasis on math games helped to increase student fluency.
- Kids had fun, had a lot of opportunities to do new things and have new experiences.
- Families were supported with nine hours of quality care for their children in the summer.

Areas for focused/needed improvement:

- More staff is needed to support the after-school program. High school students would be a great way to expand the workforce.
- Some social work support for families who are identified with needs during summer session.
- Consider expanding the number of students the program can serve all together. This is dependent on being able to hire more teachers and paraeducators to support the program.

Evaluation criteria:

- Over the 6 weeks of summer school, students went from 56% working below grade level in *Lexia*, to 36% working below grade level. This data would indicate that students made progress during their six weeks of summer school.
- Staff will disaggregate data when students take the *iReady* math and reading assessments in August to compare summer school students to non-summer school students. Staff will be able to see data from last year and determine where there was growth.

Secondary Summer School**Middle School students served: 73****High School students served: 222****Staff:**

- One Secondary Summer School Principal
- One Admin Assistant
- One Campus Supervisor
- One Social Emotional Counselor (shared with elementary)
- 4 Credit Recovery Teachers
- 8 Elective Teachers
- 2 Math Teachers
- Four Paraeducators
- Two UCSC Cal Teach student intern
- One student intern from UNR

Program Purpose and Goals:

- **Credit Recovery** (High School) - provide students the opportunity to retake courses previously failed to stay on track for graduation
- **Math Bridge** - provide incoming 9th grade students with the opportunity to engage in essential math concepts and skill development so they are ready for Integrated 1. Silicon Valley Mathematics Initiative (SVMI) research-based summer intervention math program was used. 5 elective credits could be earned.
- **Elective Wheel** (Middle & High School) - provide students with the opportunity to learn essential skills in career technical education, the practical and fine arts. Additionally, a literacy component was part of each day's lesson. High school students could earn 5 elective credits.

Program Strengths, Successes:

- There were 28 students who participated in the Math Bridge incoming 9th grade program allowing students to gain foundational math skills needed for success in Integrated Math 1.
- There was great interest and participation in the Elective Wheel program. 143 students (73 middle school & 70 high school) participated in this four-week program.

AGENDA ITEM: 8.5.1.1.

- All high school students and incoming 9th graders received 5 credits of applied/fine arts if they finished all 4 weeks of the Elective Wheel summer school program.
- Technology was used in many of the elective classes, and teachers saw an increase in students' technology skills.
- All Elective Wheel teachers had a daily literacy component to increase students' skills in reading, writing, speaking, and listening. This also provided structure and support for new teachers.
- 76% of high school students enrolled in the Credit Recovery program earned at least 5 credits. While this is not quite as high as last summer, it continues to be much higher than 2019 and other past summers (see graph below).
- The addition of the academic counselor was crucial for supporting course enrollment and correct placement of students in the Credit Recovery program.

Credit Recovery Data

5 Credits = 1 Semester of 1 Course

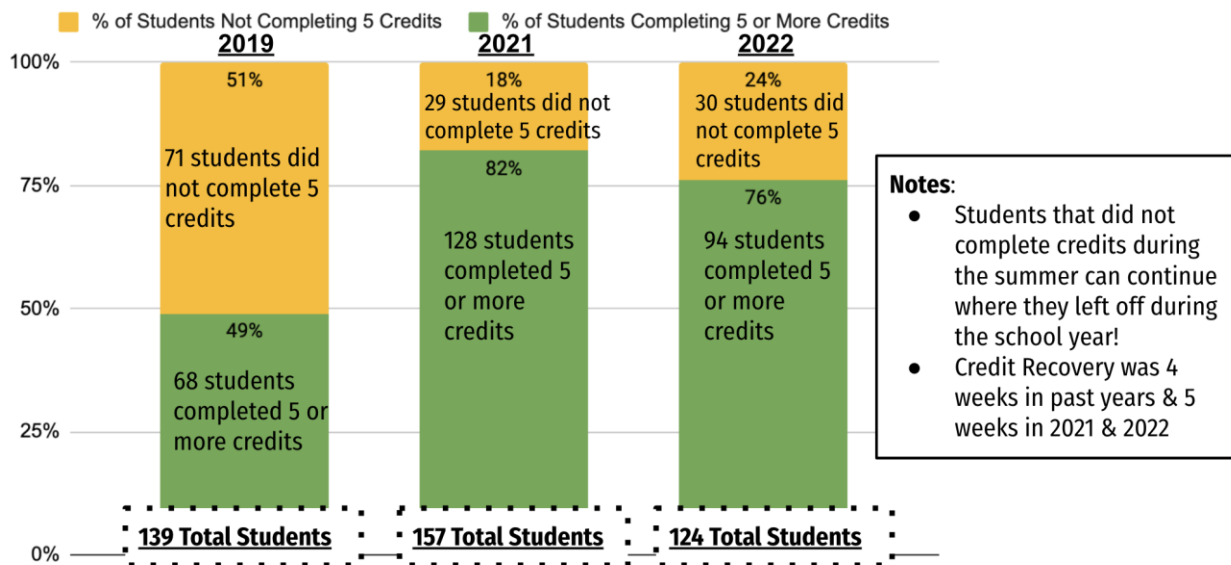

- There continues to be a high percentage of students who earn more than five credits during the Credit Recovery program, which we saw in 2021 as well. Before 2021, it was incredibly rare for a student to earn more than five credits during the summer program. Much of this is due to students being able to work on credit recovery during the school year and then finish during the summer. See the graph below for details.

2021 Credit Recovery Data

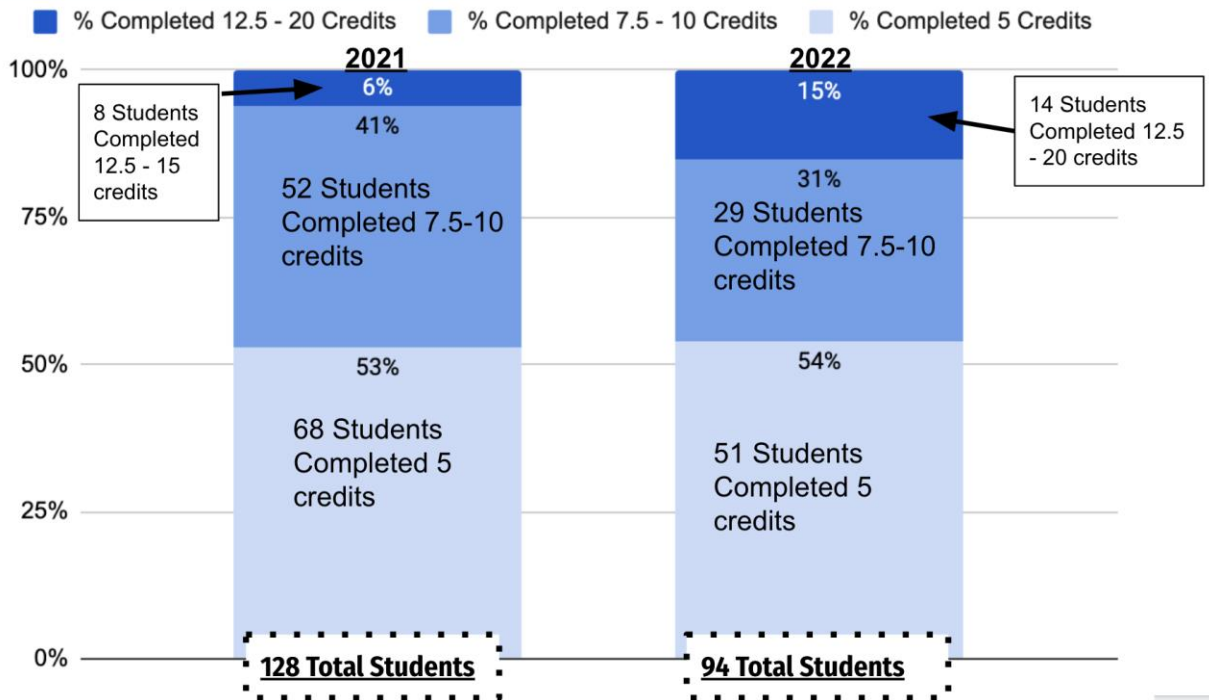

Areas for Focus/Needed Improvement:

- Continue to offer an Elective program during the summer, and if possible, increase the number of Career Technical Education and/or Visual and Performing Arts courses as these align most to student interest.
- There were a number of students that dropped out midway through the Elective Wheel program, which also happened last summer. We need to continue to work on summer program attendance and having students stick with the entire 4-week program.
- Begin Credit Recovery summer school one week later (2 weeks after the last day of school) to allow for all credits and transcripts to be finalized, which will help to ensure correct placement in credit recovery courses. All students were correctly placed this summer, but some needed to switch courses throughout the first week of the summer program.
- Allow only counselors to sign students up for credit recovery indicating the course most needed for graduation and if the student is A-G.
- An academic counselor was needed for one more week than anticipated. We only hired one for two weeks (the week before summer school and the first week of summer school).
- Secondary students participating in the Summer Program did not need as much social-emotional counselor support as anticipated. This could be reduced to 1 day a week or 2 half days a week instead of 3 days a week.
- Although Elevate was an effective math curriculum, math teachers want the district to look into using another math summer curriculum. This was due to the fact that Elevate lessons provided did not cover an entire 2-hour class period, which meant that teachers

had to create many of their own lessons to fill the whole 2 hour class period. Additionally, Elevate required families to register their students with them in addition to our district summer school registration process, which was confusing to families and caused enrollment challenges. Elevate also required attendance and grades to be assigned through their platform, which was also challenging due to having to work with a 3rd party.

Evaluation Criteria:

- The desired outcome for Credit Recovery was for at least 75% of students to complete five credits in a course needed for graduation. This goal was met with 76% of students completing five or more credits needed for graduation.
- All teachers implemented a literacy component every day to see students use writing skills. There was an increase of overall student success in articulating what they were learning and how it would be useful to their lives.
- Career and Technical Education courses like digital design, woodworking, and sustainable agriculture used project-based learning, which focused on specific standards and skills within each course offered. Teachers evaluated projects with rubrics and gave feedback to students and saw student growth in skills targeted.
- Many artforms took place through poetry, culinary arts, digital design, cultural identity artwork, and music. Students were able to increase their understanding of the basics of these artforms and all had positive feedback on the courses.
- Both Physical Education teachers allowed students to gain skills in ball sports and how to live healthy lives; one teacher had students create a wellness plan using digital skills. Physical Education teachers saw an improvement in fitness tests, taught skills, and overall joy in playing.
- Student feedback on the elective courses was overwhelmingly positive.
- Fall 2022 iReady Reading Data will be used to compare the growth middle school students made who participated in summer school compared to middle school students who did not participate to determine the impact of the summer program on students' growth and/or prevention of "summer slide" that occurs on a typical summer.

FISCAL IMPACT:

Elementary Total: \$163,680.31, Title 1 (Restricted)

Secondary Total: \$176,064.13, Title 1 (Restricted)

Total for Elementary & Secondary Summer School Programs: \$339,744.45

This work is in direct support of the following District goals and their corresponding metrics:

Goal #1: All Santa Cruz City Schools students will be prepared to successfully access post-secondary college and career opportunities.

Goal #2: SCCS will create positive, engaging school environments that promote the development of cognitive skills and the social emotional well-being of all students.

AGENDA ITEM: 8.5.1.1.

Goal #3: We will eliminate the achievement gaps that currently exist between demographic groups within the SCCS student community.



Summer School 2022

Another Summer School Program for the Books!

August 17, 2022

Overview of 2022 Summer School Programs

Elementary - Math and Readers Workshop, Social Emotional Learning, Enrichment Activities

Middle & High - 4 week Elective Wheel (CTE, VAPA, & Literacy focus) - 5 credits for HS

High - Incoming 9th Grade Math Bridge (Elevate) & Credit Recovery

Extended School Year - for students who qualify based on their IEP (focused on IEP goals & integrated with the above programs)

Social Emotional Counselor - supporting all summer programs



Elementary Program

Focused on students at least two grade levels behind

8:30-12:30: Literacy, Math, PE
Passion Project

12:30-5:30: Summer camp fun! Arts and craft, games, field trips

Breakfast, lunch & dinner served

Benchmark Workshop

summer booster curriculum



iReady myPath math intervention curriculum

- 235 students
- 165 students stayed all day
- 8:00am to 5:00 pm Gault
- 11 General Education classrooms & 4 Extended school year Special Education classes

Elementary Photos....

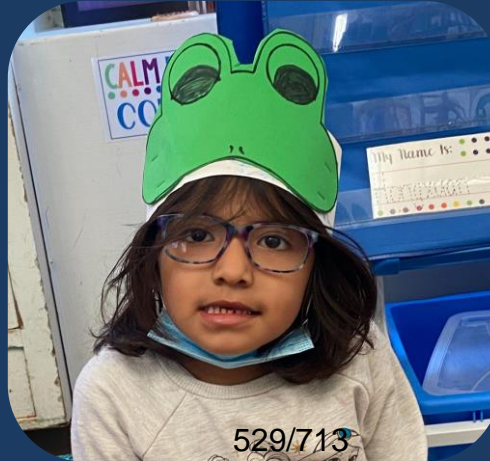
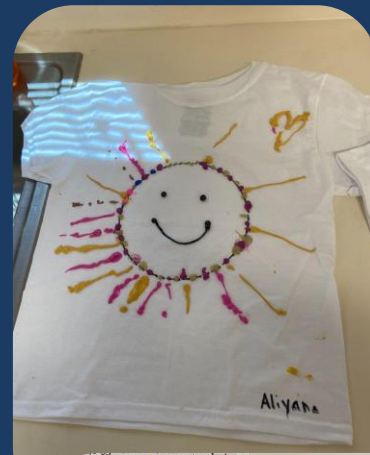
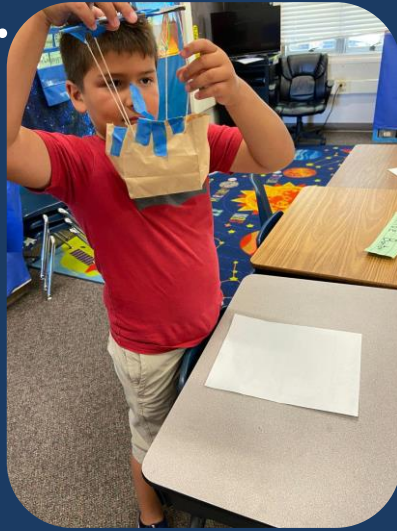

Middle & High School: Elective Wheel

- 73 middle school students
- 70 high school students
- 4 weeks
- Daily literacy component in every class
 - Personal Fitness
 - Social/Cultural Poetry
 - Digital Design
 - Music
 - Sustainable Agriculture CTE
 - Woodworking CTE
 - Culinary Arts
 - Cultural Identity within Art

Elective Wheel Photos

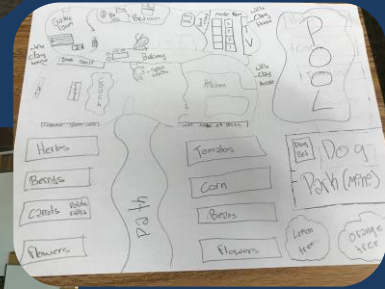
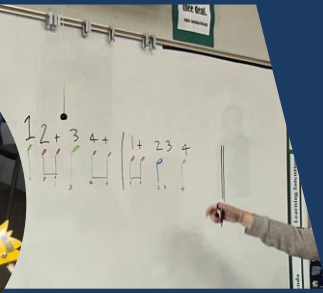
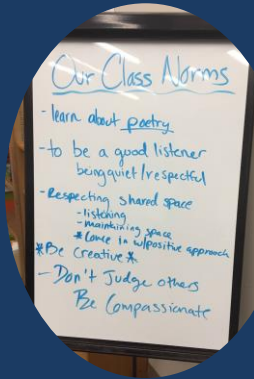

SHOW LGBTQIA+ SUPPORT BECAUSE...

EVERYONE MATTERS

LOVE WINS

PEOPLE SHOULD BE ABLE TO LOVE WHOEVER THEY WANT WITHOUT JUDGEMENT

LOVE IS LOVE

LOVE IS NEVER WRONG



High School: Incoming 9th Grade Math Bridge & Credit Recovery

9th Grade Math Bridge: 28 students

- 4 weeks long (5 elective credits)
- Silicon Valley Math Institute Elevate Summer Math Program
 - Teacher training & curriculum
 - Research based program

Credit Recovery: 124 students

- 5 weeks long
- Edgenuity (computer based) & Book based options
- A-G & Non A-G Credit Course Options

Credit Recovery Data

5 Credits = 1 Semester of 1 Course

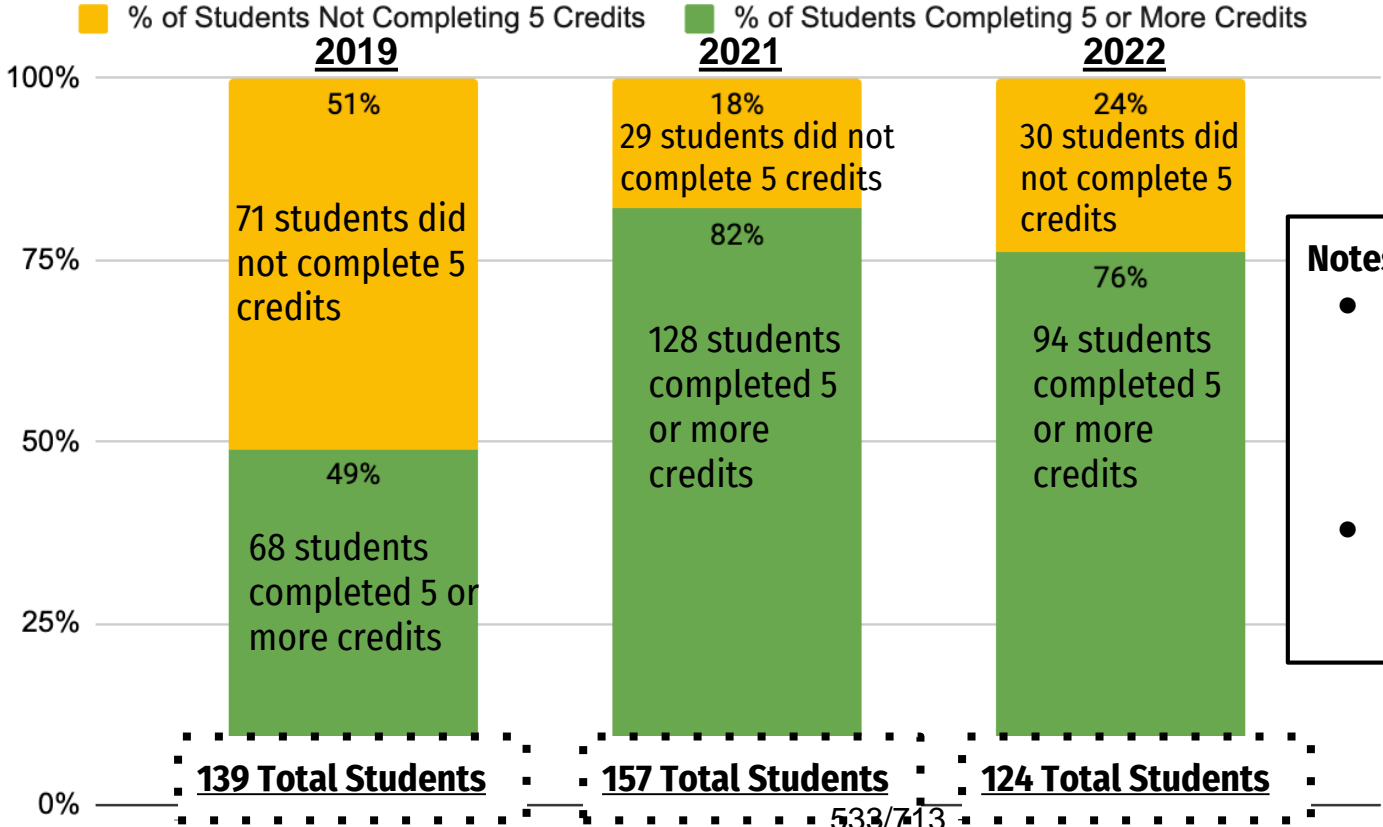

Notes:

- Students who did not complete credits during the summer can continue where they left off during the school year!
- Credit Recovery was 4 weeks in 2019 & 5 weeks in 2021 & 2022

2021 Credit Recovery Data

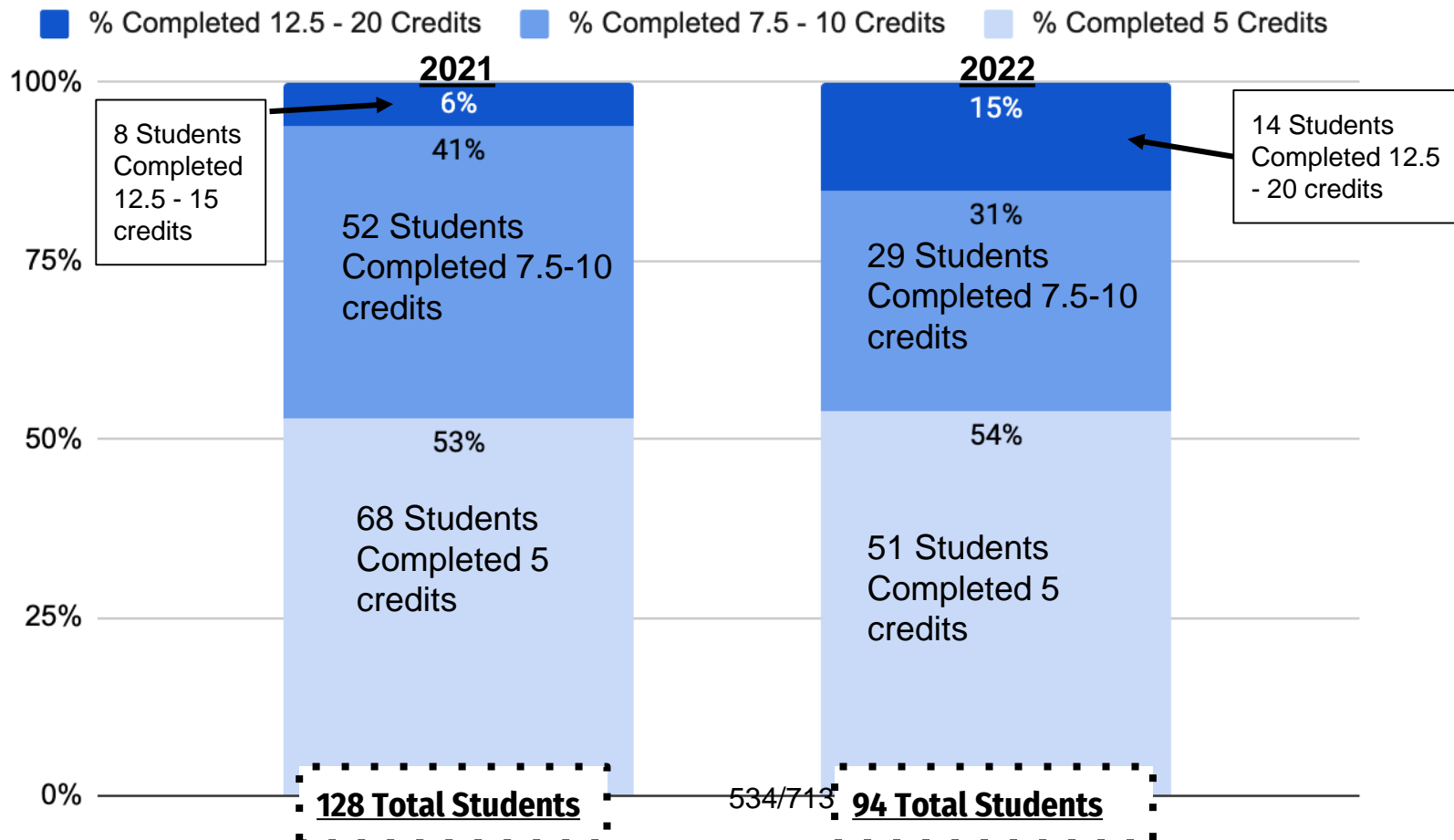

What we learned to inform next summer...

- Need more staff for elementary after school program
- Expand elementary program if staffing allows
- Need more time for academic counselor & less for social-emotional counselor
- Begin credit recovery 2 weeks after school ends - allowing time for grades & transcripts to post
- Have more credit recovery teachers in the morning & fewer in the afternoon
- Have school counselors sign students up for Credit Recovery, not parents, ensuring the correct courses
- Hold Math Bridge only in the morning & find new Bridge Math curricular program
- Continue to have both middle & high school on the same campus

Questions?



SANTA CRUZ CITY SCHOOL DISTRICT

AGENDA ITEM: Inter-District Transfers and Open Enrollment Report

MEETING DATE: August 17, 2022

FROM: Dorothy Coito, Assistant Superintendent of Educational Services

THROUGH: Kris Munro, Superintendent

BACKGROUND:

A permit authorizing attendance of a student outside his/her district of residence may be issued upon approval from the district of residence and the district of proposed attendance. Specific application guidelines for approval/denial of inter-district transfers are monitored directly through the office of the Director of Student Services.

Applications for Open Enrollment (Intra-District Transfers, or transfers between schools within the same district) are also processed through the Student Services Department, with similar guidelines and protocols.

Inter-district Transfers and instances of Open Enrollment have a direct impact on K-12 enrollment at each site and are monitored carefully. Staff meets with all families requesting new Inter-District Transfers out of the district. Additionally, phone interviews are conducted with some families when renewing their Inter-District applications. The purpose of these interviews is to identify reasons for leaving the district and allows SCCS staff to speak to available programs and opportunities.

Open Enrollment & Inter-district Transfers Trends

Open enrollment transfers between SCCS elementary schools are predominantly students who are accepted into the Two-Way Immersion Program at DeLaveaga Elementary School. For middle schools, over the last four years, more students are choosing to stay at their home schools. Open enrollment numbers for high schools remain relatively stable with a higher number of Santa Cruz High School students choosing to stay at their school.

For Inter-district Transfers, SCCS releases elementary and secondary students based only on Ed Code exceptions. These exceptions include the following: siblings in the other district, students staying with their graduating class, and participation in special programs. As a result, there has been a decline in students transferring out of the district. Over the last four years, there has been an increase of students transferring into our district. We have approved more elementary transfers due to siblings enrolled in our district and we have accepted more of our employee's students. Additionally, there is an increase of students entering our secondary schools over the last five years.

FISCAL IMPACT:

The elementary revenue formula is driven by the tax base and the secondary revenue formula is determined by average daily attendance rates. Enrollment directly determines secondary revenue. Both elementary and secondary expenditures for staffing and programs are also impacted by enrollment.

This work is in direct support of the following District goals and their corresponding metrics:

Goal #2: SCCS will create positive, engaging school environments that promote the development of cognitive skills and the social emotional well-being of all students.

Goal #3: We will eliminate the achievement gaps that currently exist between demographic groups within the SCCS student community.

Goal #6: SCCS will maintain strong communication and partnership with its diverse community.

Prepared by Gail Atlansky, Director of Student Services



Open Enrollment & Interdistrict Transfer Update

August 17, 2022

Definitions

Open Enrollment (OE)

Transfer of students between schools within our district

Students are approved based on program and space

Interdistrict Transfers (IDT)

Transfer of students between different districts

Students are approved based on program and space



Open Enrollment

Open Enrollment Policy BP 5116.1

Parents/guardians of any student who resides within district boundaries may apply to enroll their child in any district school regardless of the location of the residence within the district

No student currently residing within a school's attendance area shall be displaced by another student transferring from outside the attendance area

Elementary Open Enrollment

22-23			21-22			20-21			19-20		
From	To		From	To		From	To		From	To	
BV	DL	2	BV	DL	2	BV	DL	10	BV	DL	2
	Gault	0		Gault	0		Gault	2		Gault	2
	WL	4		WL	16		WL	8		WL	0
Total Out / Total In		6/3			18/9			20/18			4/8

Elementary Open Enrollment

22-23			21-22			20-21			19-20		
From	To		From	To		From	To		From	To	
DL	BV	2	DL	BV	3	DL	BV	1	DL	BV	3
	Gault	2		Gault	3		Gault	5		Gault	11
	WL	1		WL	2		WL	4		WL	1
Total Out / Total In		5/15			8/29			10/21			15/11

Elementary Open Enrollment

22-23			21-22			20-21			19-20		
From	To		From	To		From	To		From	To	
Gault	BV	0	Gault	BV	4	Gault	BV	9	Gault	BV	1
	DL	8		DL	17		DL	8		DL	7
	WL	1		WL	1		WL	0		WL	0
Total Out / Total In		9/2			22/3			17 / 8			8/13



Elementary Open Enrollment

22-23			21-22			20-21			19-20		
From	To		From	To		From	To		From	To	
WL	BV	1	WL	BV	2	WL	BV	8	WL	BV	4
	DL	5		DL	4		DL	3		DL	2
	Gault	0		Gault	0		Gault	1		Gau lt	0
Total Out / Total In		6/6			6/19			12/12			6 / 1
					546/713						



Open Enrollment Longitudinal Data Reflection for Elementary

For Elementary, from 2021-22 to 2022-23 students were only approved to transfer between our elementary schools for:

- **Two Way Immersion and Monarch**
- **If they moved and want to remain at their same school**
- **If they have siblings at requested school**

A focused effort was made to maintain balanced enrollment at our elementary sites

Middle School Open Enrollment

22-23			21-22			20-21			19-20		
From	To	Students	From	To	Students	From	To	Students	From	To	Students
B40	MH	20	B40	MH	31	B40	MH	30	B40	MH	40
MH	B40	8	MH	B40	5	MH	B40	12	MH	B40	17

High School Open Enrollment- Harbor High

22-23			21-22			20-21			19-20		
From	To		From	To		From	To		From	To	
HHS	SCHS	78	HHS	SCHS	81	HHS	SCHS	61	HHS	SCHS	67
	SHS	15		SHS	11		SHS	11		SHS	12
Total Out		93	Total Out		92			72			79
Total In		122	Total In		152			154			135



High School Open Enrollment- Santa Cruz High

22-23			21-22			20-21			19-20		
From	To		From	To		From	To		From	To	
SCHS	HHS	3	SCHS	HHS	16	SCHS	HHS	10	SCHS	HHS	13
	SHS	1		SHS	6		SHS	1		SHS	2
Total Out		4			22			11			15
Total In		105			113			89			94



High School Open Enrollment- Soquel High

22-23			21-22			20-21			19-20		
From	To		From	To		From	To		From	To	
SHS	HHS	119	SHS	HHS	136	SHS	HHS	144	SHS	HHS	122
	SCHS	27		SCHS	32		SCHS	28		SCHS	27
Total Out		146			168			172			149
Total In		16			17			12			14



Open Enrollment Longitudinal Data Reflection for Secondary

Middle Schools

- **Over the course of the last four years we are seeing more families staying in their home schools.**

High Schools

- **There has been significant movement between our high schools with least amount of movement out of SCHS.**
- **The impact of open enrollment is off set by IDTs entering our district.**



Interdistrict Transfers

Allowable Reasons for Interdistrict Transfers BP 5117 (Based on Ca. Ed. Code)

- **Student has been determined to be a victim of bullying**
- **Child care needs**
- **Mental/Physical Health needs as certified by appropriate personnel**
- **Sibling in receiving district**
- **Completion of current school year (after moving)**
- **Remain with graduating class in current year**

Allowable Reasons for Interdistrict Transfers BP 5117 (Based on Ca. Ed. Code)

- **Allow HS Senior to attend same school as Junior year (after moving)**
- **Written evidence of future residency**
- **Student will be living out of district for 1 year or less**
- **SARB/Court**
- **Program not offered in district of residence**
- **Change in environment for reasons of personal/social adjustment**

Site	22-23	21-22	20-21	19-20
Bay View	6	5	9	10
DL	21	18	18	13
Gault	6	5	7	1
WL	12	10	7	8
Monarch	1	1	0	0
Staff IDTs	31	22	18	25

**Comprehensive
Elementary
Interdistrict
Transfers into
SCCS**

District	22-23	21-22	20-21	19-20
Bonny Doon	1	1	1	1
Live Oak	15	15	13	11
Pajaro Valley	4	8	3	4
San Lorenzo Valley	6	4	5	5
Soquel Union	12	6	14	8
Scotts Valley	6	4	4	3
North Monterey County	1	1	1	2
Happy Valley	1	0	0	1

557/713

Entering IDT Districts of Origin- Elementary

Site	22-23	21-22	20-21	19-20	18-19
BMS	30	28	25	32	21
MHMS	23	25	21	26	14

Comprehensive Middle School IDTs (Entering)

Comprehensive High School IDTs (Entering)

Site	22-23	21-22	20-21	19-20	18-19
Harbor High School	49	66	67	58	31
Santa Cruz High School	86	67	51	56	45
Soquel High School	127	136	157	137	111

District	22-23	21-22	20-21	19-20
Live Oak	11	15	18	17
Pajaro Valley	176	213	230	205
San Lorenzo Valley	35	37	34	27
Soquel Union	17	23	26	23
Scotts Valley	64	48	31	33
Los Gatos/Saratoga	4	2	1	1
Bonny Doon	3	3	0	2

**Entering IDT
Districts of
Origin - All
Secondary
Middle & High**

Data Reflection - Entering IDTs

- **Elementary: There is an increase in students entering our district over the last four years**
- **Middle School: IDTs have more than doubled over the last five years.**
- **High School: Overall increasing number of IDTs**

Specific restrictions in limiting *Outgoing* IDT Requests

- **Number of student transfers out has reached limit specified in Ed Code 48307 (Based on no more than 3% ADA which is 58 students in Elementary and 132 students in Secondary)**
- **Negative budget certification**
- **Negative impact on court ordered/voluntary desegregation**
- **Racial and ethnic balance of the district (Ca. Constitution Art 1: Sec 31)**

KEY: Family Reported Reasons for Outgoing IDTs

- **Childcare**
- **Program Preference: Programs not offered by SCCS**
- **Safety: Request made due to physical/emotional well being**
- **Graduating Class: to remain with peers in current school setting (5th/7th/12th)**
- **Family moved to SCCS but wanted to remain with peers**

KEY: Family Reported Reasons for Outgoing IDTs

- **Sibling currently attends requested school**
- **Parent works in or near requested school**
- **Directives of SARB or other court process i.e. probation/foster youth plan**
- **Parent indicated specific bullying at school of residence**
- **Convenience: Logistics/Carpool/Route to work**

Outgoing IDTs for Elementary

	22-23	21-22	20-21	19-20
Elementary	222	257	268	245

District	22-23	21-22	20-21	19-20
Live Oak	46	39	64	59
Pajaro Valley	5	9	6	4
San Lorenzo Valley	6	4	5	5
Soquel Union	14	21	16	23
Scotts Valley	33	65	76	85
Pacific	76	73	80	81
Happy Valley	13	16	18	22

Exiting IDT Districts- Elementary

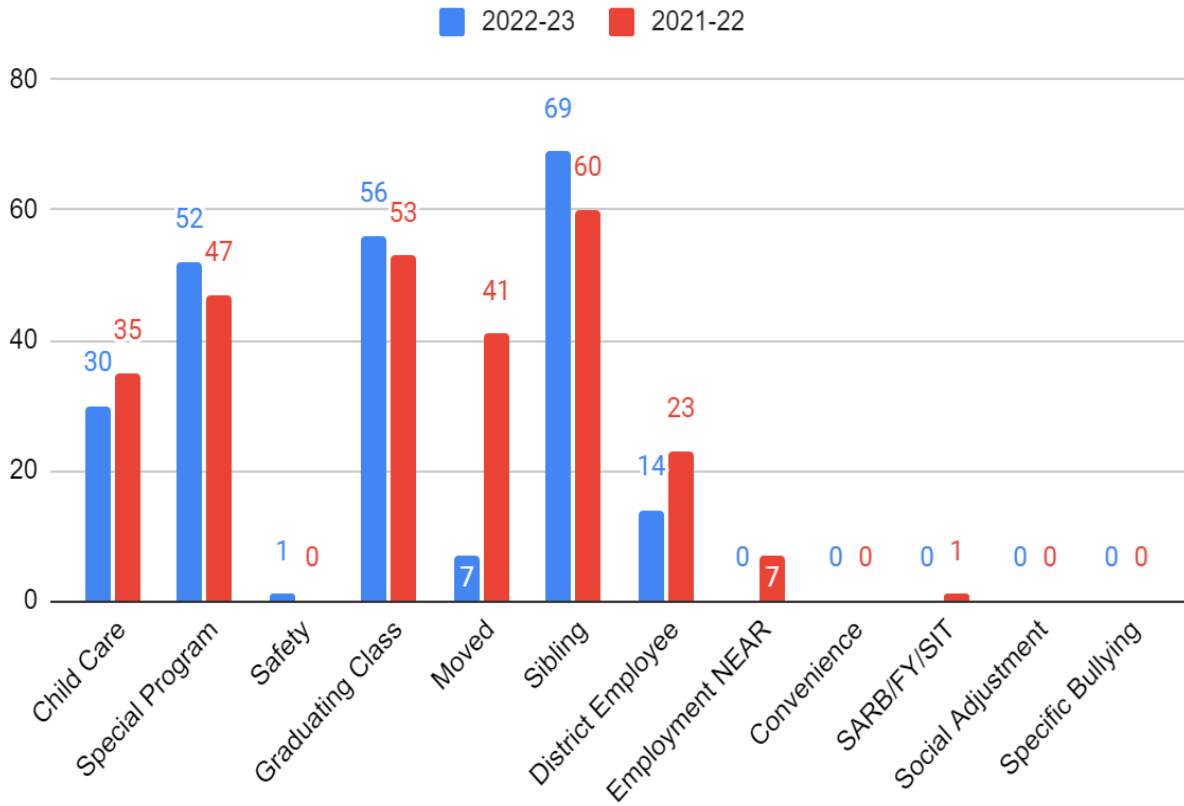

TK-5th Grade Family Reasons for Exiting: 2021- 22 vs 2022-23

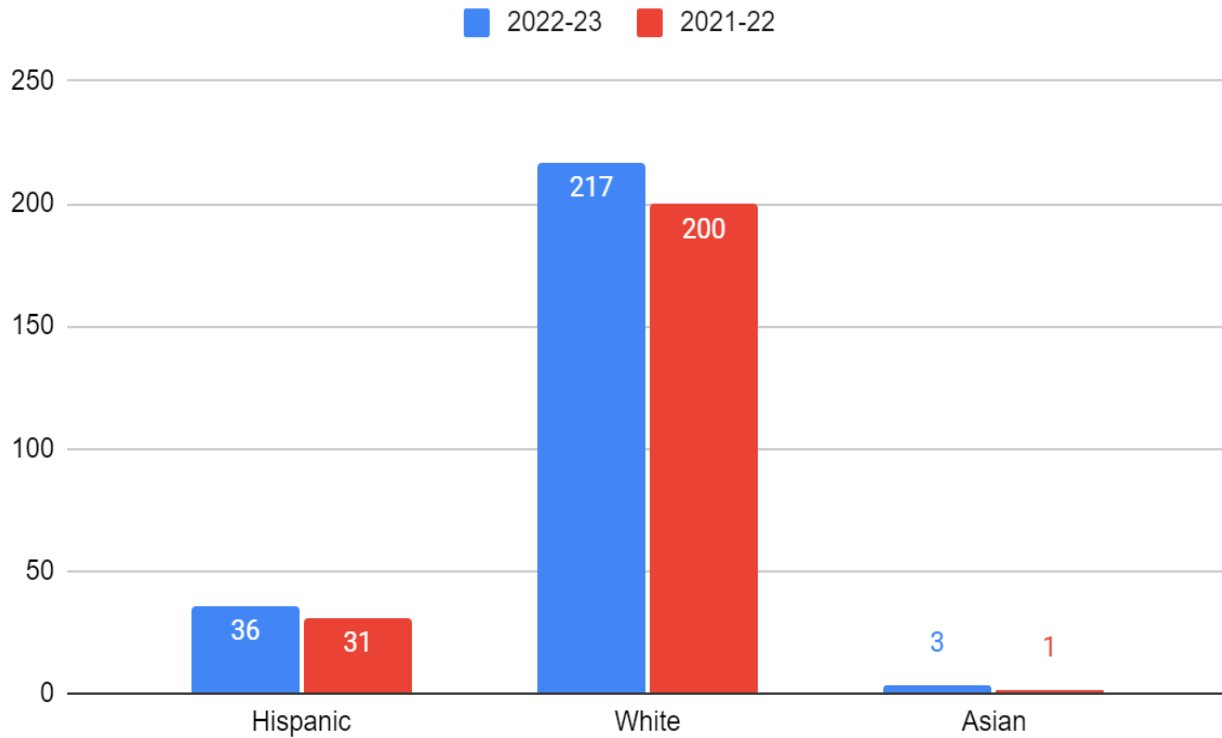

Outgoing TK-5th IDT Request by Ethnicity

568/713

TK - 5th Outgoing IDT by Ethnicity

Data Reflection: Outgoing IDT Trends for Elementary

Elementary outgoing IDTs have been declining since 2020-21 due only releasing per Ed Code

Greatest number of outgoing transfer requests are:

- **To remain with graduating class**
- **Student has sibling in other district**
- **Specialized program in other district**

Majority of outgoing IDTs for elementary are for Pacific Elementary, Live Oak, and Scotts Valley Unified School Districts

Outgoing IDTs for Secondary

	22-23	21-22	20-21	19-20
Secondary	253	287	299	321

District	22-23	21-22	20-21	19-20
Happy Valley	3	2	3	4
Live Oak	29	36	33	38
Pacific	7	7	7	6
Pajaro Valley	27	30	26	34
San Lorenzo Valley	18	29	38	51
Soquel Union	24	26	16	22
Scotts Valley	130	150	154	161

Exiting IDT Districts of Origin- Secondary

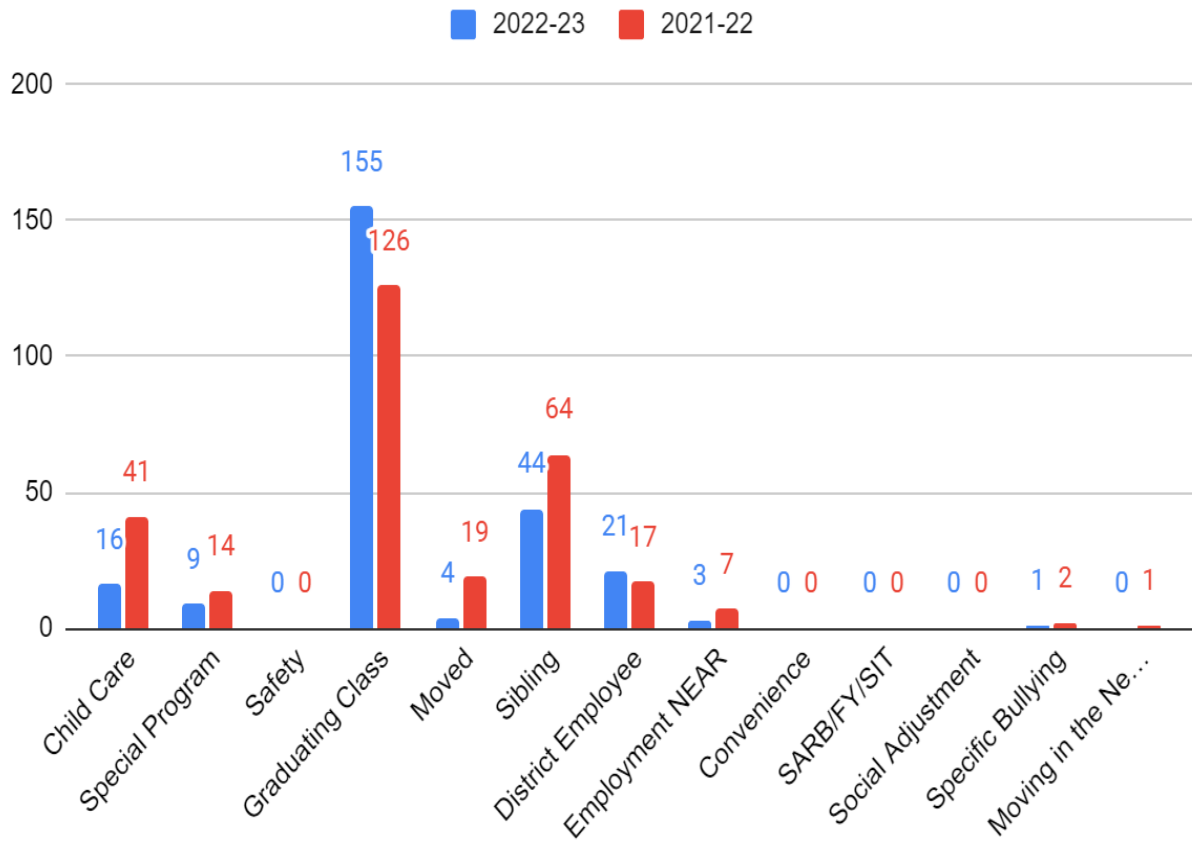

6th - 12th Grade Family Reasons for Exiting: 2021- 22 vs 2022-23

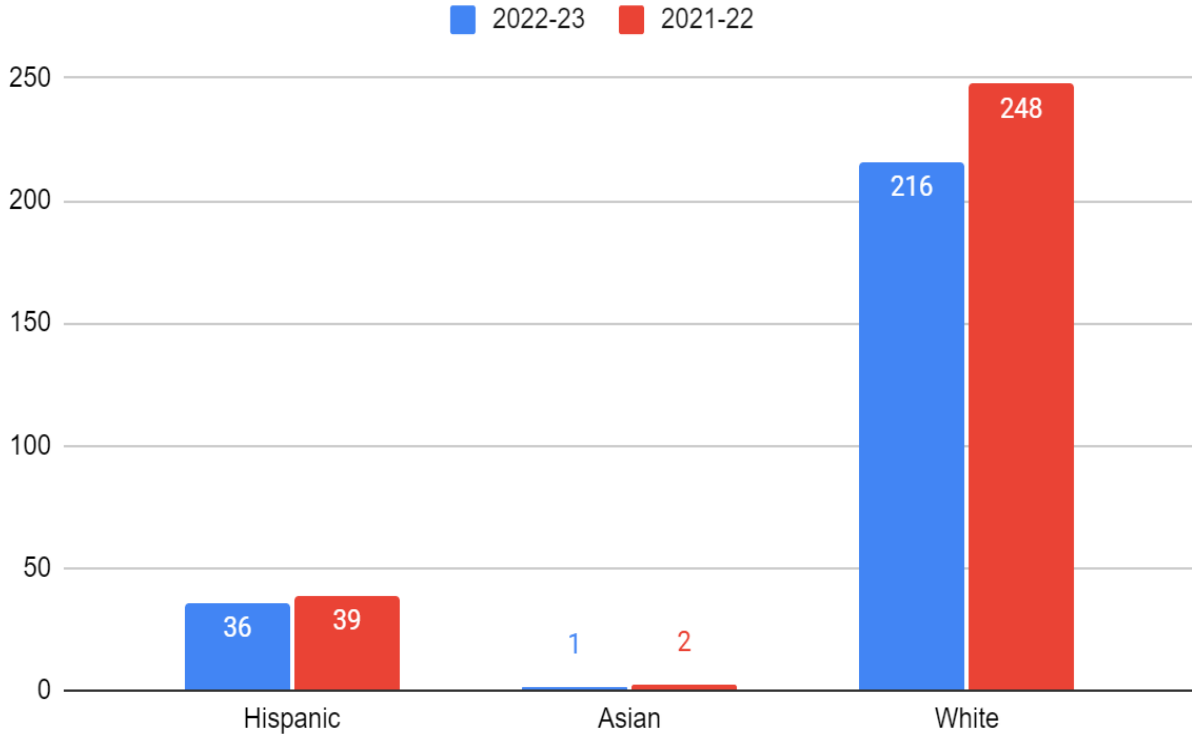

Outgoing 6th-12th IDT Request by Ethnicity

6th - 12th Outgoing IDT by Ethnicity

Data Reflection: Outgoing IDT Trends for Secondary

- **Secondary outgoing IDTs have been declining since 2020-21 due to only releasing per Ed Code**
- **Secondary incoming IDTs from 21-22 to 22-23 were relatively stable**
- **Greatest number of outgoing transfer requests were to remain with graduating class or sibling in other district**
- **Majority of outgoing secondary IDTs were to Scotts Valley Unified School District**

Questions?

SANTA CRUZ CITY SCHOOL DISTRICT

AGENDA ITEM: Bond Project Update

MEETING DATE: August 17, 2022

FROM: Jim Monreal, Assistant Superintendent, Business Services

THROUGH: Kris Munro, Superintendent

BACKGROUND:

David Peartree from Belli Architects will present an update on Measure A Bond projects at Branciforte Middle School and Harbor High School, and District bond projects at Maintenance Operations and Transportation and the Central Kitchen.

FISCAL IMPACT:

\$2,500 Measure A Bond (Restricted)

This work is in direct support of the following District goals and their corresponding metrics:

- Goal #2: SCCS will create positive, engaging school environments that promote the development of cognitive skills and the social emotional well-being of all students.
- Goal #5: SCCS will maintain a balanced budget and efficient and effective management.
- Goal #6: SCCS will maintain strong communication and partnership with its diverse community.

MEASURE A BOND PROJECT UPDATES FOR:

BRANCIFORTE MIDDLE SCHOOL

HARBOR HIGH SCHOOL

SCCS DISTRICT-WIDE FACILITIES



AUGUST 17, 2022



BRANCIFORTE MIDDLE SCHOOL



BRANCIFORTE MS – PROJECT STATUS

LEGEND

Work Completed

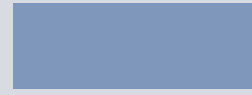

- Roof Replacement
- New Music Building
- Parking Lot / Access Control
- New Covered Lunch Area
- MPR Modernization
- Street Presence and Improvements
- Data Infrastructure Improvements

Work Upcoming

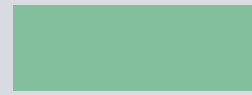

- Classroom Modernization
- Administration Modernization
- Library Modernization

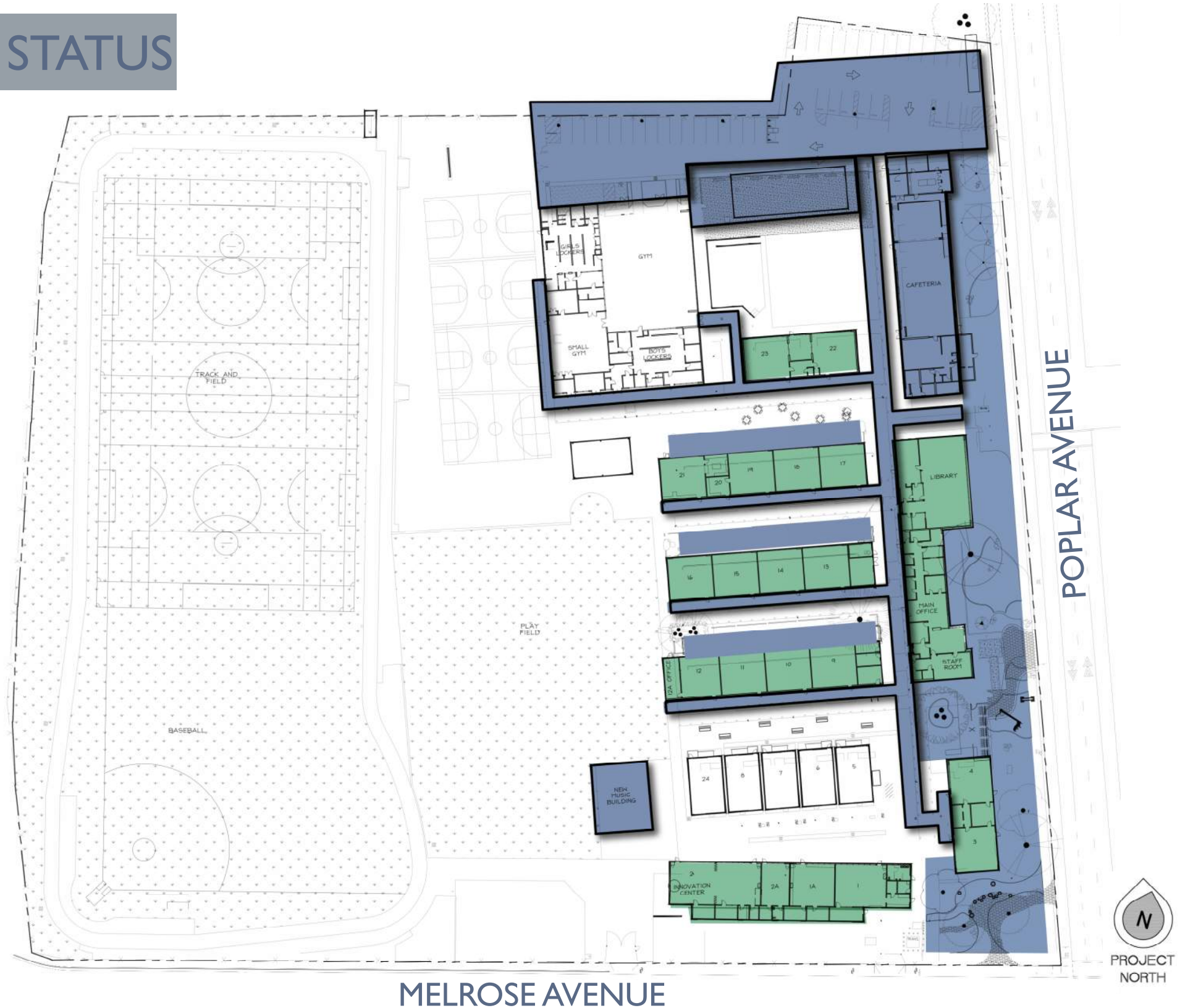

HARBOR HIGH SCHOOL



HARBOR HS – PROJECT STATUS

LEGEND

Work Completed

- Athletic Fields Improvements
- Roof Replacement
- Tennis Court Renovation
- Student Locker Remodel
- Electrical Service Replacement
- Hand Dryers / Drinking Fountains
- New Swimming Pool and Weight Room
- Data Infrastructure Modernization

Work in Progress

- FA building Theatre Electrical Safety Project
- Card Access Security System

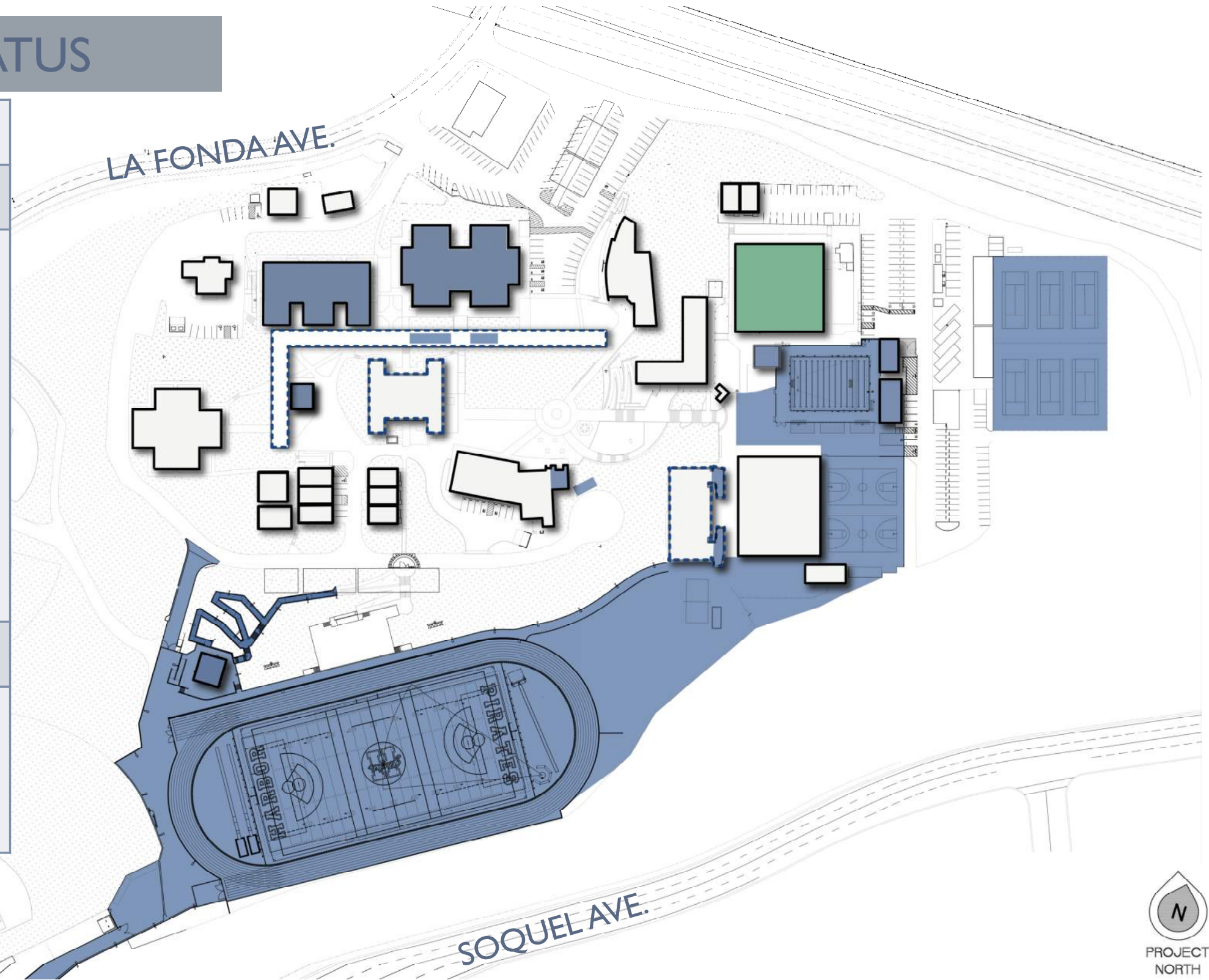

SCCS MAINTENANCE YARD PAVING REPLACEMENT



MAINTENANCE YARD – PROJECT STATUS

LEGEND

Work in Progress



-Maintenance Yard Paving Replacement

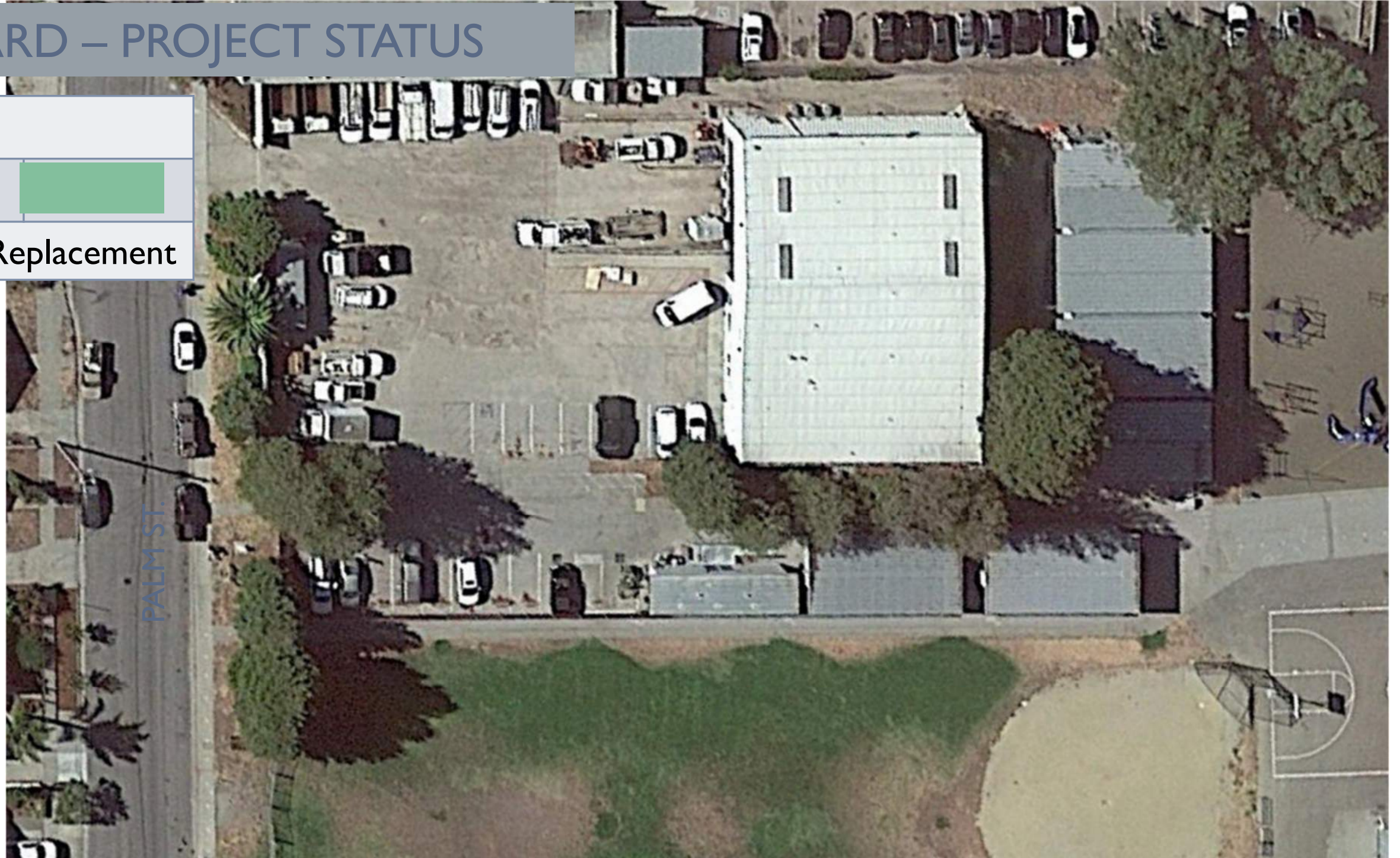

MAINTENANCE YARD PAVEMENT REPLACEMENT – PARTIAL SITE PLAN



MAINTENANCE YARD PAVEMENT REPLACEMENT



SCCS TRANSPORTATION YARD NEW OFFICE BUILDING



TRANSPORTATION YARD – PROJECT STATUS

LEGEND

Work in Progress



-Transportation Yard

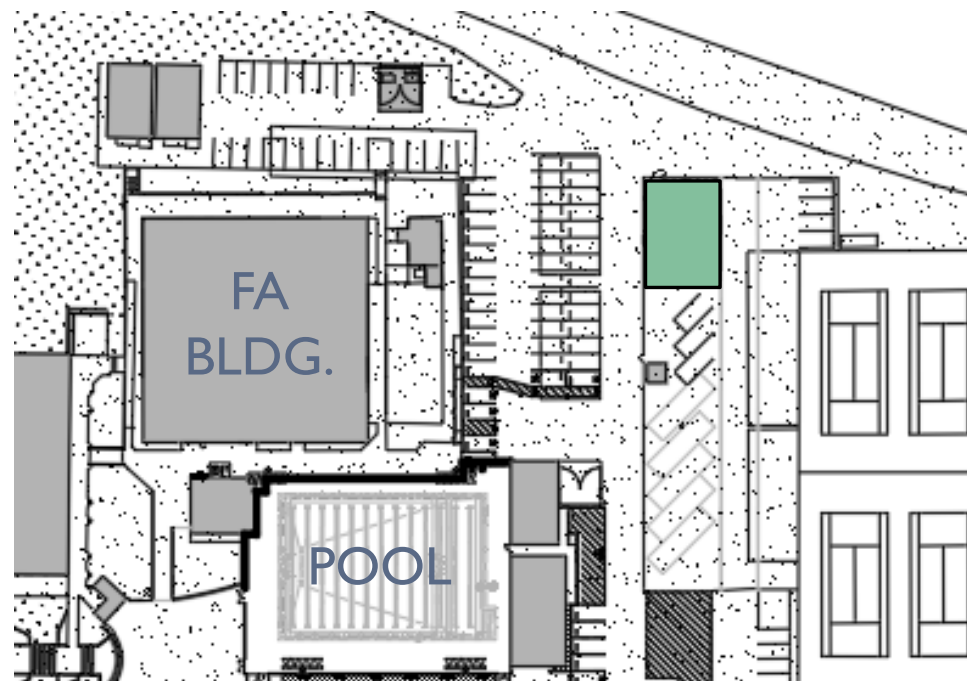

ENLARGED SITE PLAN



EXTERIOR PERSPECTIVE RENDERING
UNDER CONSTRUCTION – PARTIAL SITE PLAN (HARBOR HS)





UNDER CONSTRUCTION – NEW TRANSPORTATION YARD OFFICE



SCCS CENTRAL KITCHEN – COLD STORAGE ADDITION



CENTRAL KITCHEN – PROJECT STATUS

LEGEND

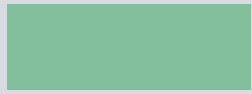
Work in Progress 

-Central Kitchen Cold Storage Add.

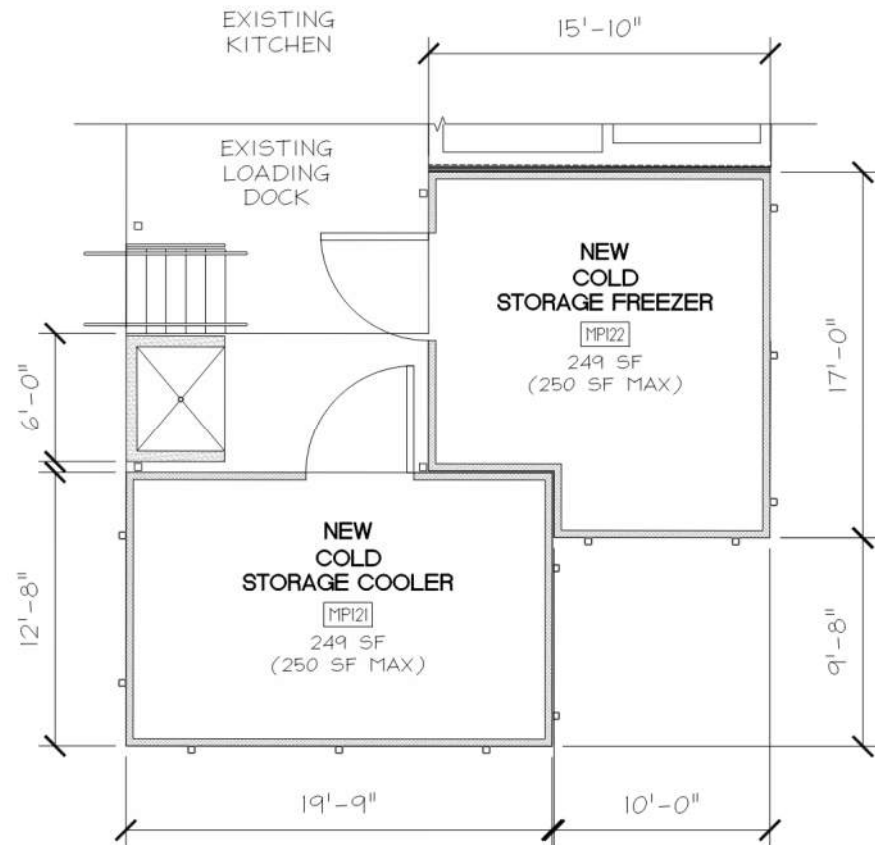

PROPOSED FLOOR PLAN

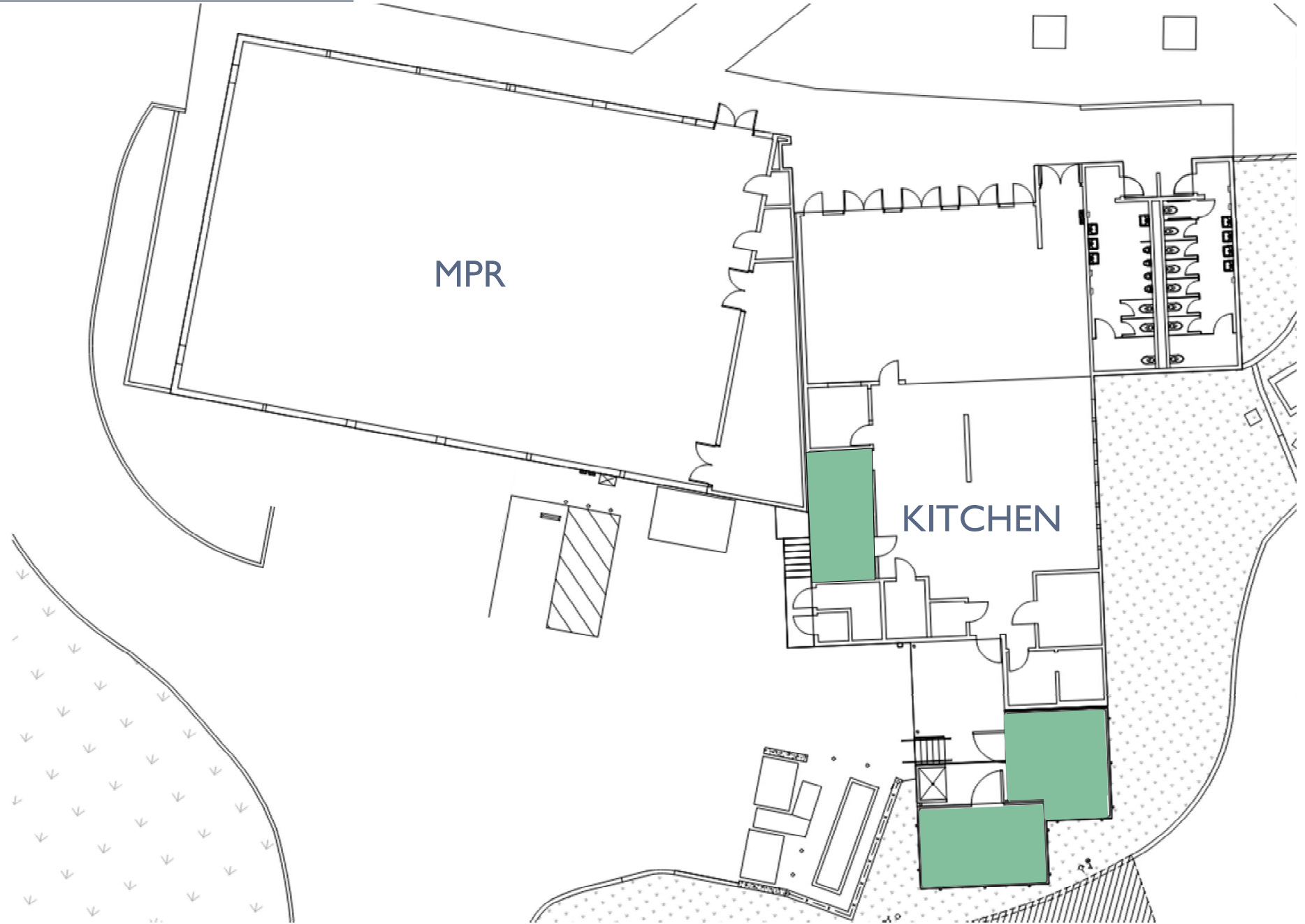

ENLARGED SITE PLAN (HARBOR HS)



THANK YOU



SANTA CRUZ CITY SCHOOL DISTRICT

AGENDA ITEM: AB 1200 Public Disclosure on Tentative 2022-23 Collective Bargaining Agreement, between Santa Cruz City Schools and the Greater Santa Cruz Federation of Teachers (GSCFT)

MEETING DATE: August 17, 2022

FROM: Jim Monreal, Assistant Superintendent, Business Services

THROUGH: Kris Munro, Superintendent

RECOMMENDATION:

Approve AB 1200 Public Disclosure on tentative bargaining agreement with the Greater Santa Cruz Federation of Teachers for 2022-23.

BACKGROUND:

A tentative bargaining agreement for 2022-23 has been reached with the District's certificated bargaining unit, the Greater Santa Cruz Federation of Teachers. The Board is required by AB 1200 to make this tentative agreement available to the public, to publicly disclose its costs.

The proposed agreement for 2022-23 will provide a 5% increase on the certificated salary schedule, starting July 1, 2022.

A one-time off salary schedule payment of \$1,000 for FTE .51 to 1.00 (+) FTE and \$500 for FTE of .50 or below for 2022-23.

FISCAL IMPACT:

- A recurring annual cost of \$2,367,822
- A one-time cost of \$497,846

Funding Sources: LCFF Base (Unrestricted), LCFF Supplemental (Restricted), Federal Categorical Programs (Restricted), State and Local Funds (Restricted and Unrestricted).

This work is in direct support of the following District goals and their corresponding metrics:

Goal #5: SCCS will maintain a balanced budget and efficient and effective management.

Goal #6: SCCS will maintain strong communication and partnership with its diverse community.

AGENDA ITEM: 8.5.2.2.

Government Code - GOV

TITLE 1. GENERAL [100 - 7914]

(Title 1 enacted by Stats. 1943, Ch. 134.)

DIVISION 4. PUBLIC OFFICERS AND EMPLOYEES [1000 - 3599]

(Division 4 enacted by Stats. 1943, Ch. 134.)

CHAPTER 10.7. Meeting and Negotiating in Public Educational Employment [3540 - 3549.3]

(Chapter 10.7 added by Stats. 1975, Ch. 961.)

ARTICLE 8. Public Notice [3547 - 3547.5]

(Article 8 added by Stats. 1975, Ch. 961.)

PUBLIC DISCLOSURE OF COLLECTIVE BARGAINING AGREEMENT

3547.5.

(a) Before a public school employer enters into a written agreement with an exclusive representative covering matters within the scope of representation, the major provisions of the agreement, including, but not limited to, the costs that would be incurred by the public school employer under the agreement for the current and subsequent fiscal years, shall be disclosed at a public meeting of the public school employer in a format established for this purpose by the Superintendent of Public Instruction.

(b) The superintendent of the school district and chief business official shall certify in writing that the costs incurred by the school district under the agreement can be met by the district during the term of the agreement. This certification shall be prepared in a format similar to that of the reports required pursuant to Sections 42130 and 42131 of the Education Code and shall itemize any budget revision necessary to meet the costs of the agreement in each year of its term.

(c) If a school district does not adopt all of the revisions to its budget needed in the current fiscal year to meet the costs of a collective bargaining agreement, the county superintendent of schools shall issue a qualified or negative certification for the district on the next interim report pursuant to Section 42131 of the Education Code.

(Amended by Stats. 2004, Ch. 52, Sec. 17. Effective June 21, 2004.)

COE NOTE:

NOTE: A Side letter – not ratified by union membership – does not require a public disclosure or to go to board, unless it has a fiscal impact.

Santa Cruz County Office of Education
Business Services Division

Public Disclosure of Collective Bargaining Agreement (AB1200 Form)

This Excel form should be sent to the COE at least 10 calendar days prior to the District's Board meeting that will have a compensation settlement between the district and a bargaining unit as an agenda item.

Please email the form, TA and other supporting documentation to:

coe_business_help@santacruzcoe.org

For additional information concerning this document and process, please contact Jean Gardner, at (831) 466-5604 or by email at:

jgardner@santacruzcoe.org

The timing between union ratification and the AB1200 deadline is not as critical; just need to submit at least 10 days prior to the public meeting where the disclosure will be discussed.

Government Code 3547.5

This full packet must be included in board packet, and a PUBLIC meeting must be held. (not a public hearing)

The disclosure of major provisions and cost comes first, 2nd Item the board approves the agreement/ratification.

Probably advisable to post full disclosure with announcement of/posting of Agenda.

Include all costs in ALL FUNDS on page 1, even if they are already budgeted.
only complete the year 2 and year 3 column if the agreement in a multi-year agreement.
if it's a one year agreement, even if ongoing costs, do not include costs in those columns.
for HW increases, the year ends 9/30 so costs would be included in year 2.

COE Website link to most recent form:

http://www.santacruzcoe.org/business/dist_support_services/forms.html

Form updated: 3/21/2019

**Santa Cruz County Office of Education
Business Services Department**

**PUBLIC DISCLOSURE OF COLLECTIVE BARGAINING AGREEMENT
in Accordance with AB 1200 (Chapter 1213/1991), GC 3547.5, and CCR, Title V, Section 15449**

Name of School District: Santa Cruz City Schools
 Name of Bargaining Unit: Greater Santa Cruz Federation of Teachers
 Certificated or Classified: Certificated

The proposed agreement covers the period beginning: July 1, 2022 and ending: June 30, 2023
 (date) (date)

The Governing Board will act upon this agreement on: August 17, 2022
 (date)

Note: This form, along with a copy of the proposed agreement, must be submitted to the county office at least ten (10) working days prior to the date the governing board will take action.

A. Proposed Change in Compensation

Compensation	Annual Cost Prior to Proposed Agreement FY 2022-23	Fiscal Impact of Proposed Agreement		
		Year 1 Increase/(Decrease) FY 2022-23	Year 2 Increase/(Decrease) FY	Year 3 Increase/(Decrease) FY
1 Salary Schedule Increase (Decrease)	\$34,316,762	\$1,715,838		
		5.00%	0.00%	0.00%
2 Step and Column - Increase (Decrease) Due to movement plus any changes due to settlement				
		0.00%	0.00%	0.00%
3 Other Compensation - Increase (Decrease)(Stipends, Bonuses, Longevity, Overtime, etc.) **Included in base above		\$389,000		
Description of other compensation: \$1,000 Bonus for FTE above 0.51 and \$500 bonus for FTE 0.50 to .10				
4 Statutory Benefits - STRS, PERS, FICA, WC, UI, Medicate etc.	\$7,880,844	\$465,992		
		5.91%	0.00%	0.00%
5 Health/Welfare Plans	\$3,716,762	\$0		
		0.00%	0.00%	0.00%
6 Total Compensation - Increase (Decrease) (Total Lines 1-5)	\$45,914,368	\$2,570,830	\$0	\$0
7 Total Number of Represented Employees (Use FTEs if appropriate)	394.40			
8 Total Compensation Average Cost per Employee	\$ 116,416.63	\$ 6,518.38	\$ -	\$ -
		5.60%	0.00%	0.00%

9. What was the negotiated percentage increase approved? For example, if the increase in "Year 1" was for less than a full year, what is the annualized percentage of that increase for "Year 1"?

For 2022-23 the District and GSCFT agreed to a 5.00% increase on the salary schedule. In addition to the 5% a one-time off the salary schedule payment of \$1,000 will be paid to employees 0.51 FTE and above. A one-time off the salary schedule payment of \$500 will be paid to employees 0.50 FTE and below. This one-time off the salary schedule payment will be paid to employees who are employed by the first day of school, August 10, 2022, and remain employed on the date of distribution of payment.

10. Were any additional steps, columns, or ranges added to the schedules? (If yes, please explain.)

CTE Stipend will be added to the stipend schedule along with the stipend requirements of \$1,882.

11. Please include comments and explanations as necessary.

The hourly rate of pay assignments not covered by a salary schedule or individual contract shall be \$40.00 beginning August 10, 2022. The rate of pay for classroom teachers serving as a guest teacher on their duty free preparation period, or during uncontracted time will be \$50 per hour. If a teacher is asked to act as a substitute by covering another teacher's class while they are simultaneously teaching their own class, the teacher will be compensated at the \$50 per hour rate. Guest Teacher Contract: New rates for subbing beginning August 10, 2022 will be: \$150 per day up to 20 days and \$180 per day after 20 days.

12. Does this bargaining unit have a negotiated cap for Health and Welfare benefits? Yes No

If yes, please describe the cap amount.

B. Proposed Negotiated Changes in Noncompensation Items (i.e., class size adjustments, etc.)

Grade level teacher(s) may agree, with administrator approval, to increase class size(s) by one student per class in order to avoid the creation of a combination class if permitted by ed code and the contract. Teachers assigned to combination classes will be allocated \$600, not including programs or school of choice (Monarch and TWI)

C. What are the specific impacts on instructional and support programs to accommodate the settlement?

Please indicate the status of these changes: 1) planning stage, 2) in-progress, or 3) adopted. Include the impact of changes such as staff reductions or increases, program reductions or increases, elimination or expansion of other services or programs (i.e., counselors, librarians, custodial staff, etc.)

None

D. What contingency language is included in the proposed agreement? Include specific areas identified reopeners, applicable fiscal years, and specific contingency language.

None

E. Will this agreement create, increase or decrease deficit spending in the current or subsequent year(s)? "Deficit spending" is defined to exist when a fund's expenditures and other financing uses exceed its revenues and other financing sources in a given year. If yes, explain the amounts and justification for doing so.

Yes, this will increase the deficit spending and the district does have a reserve over the 3% minimum to cover these costs.

F. Describe other major provisions that do not directly affect the district's costs, such as binding arbitrations, grievance procedures, etc. Please disclose any other components of the agreement which may or may not affect the district's fund balance in future years.

None

G. Source of Funding for Proposed Agreement

1. Current Year

General Fund Unrestricted and Restricted Funds.

2. If this is a single year agreement, how will the on-going cost of the proposed agreement be funded in subsequent years (i.e., what will allow the district to afford this contract)?

3. If this is a multiyear agreement, what is the source of funding, including assumptions used, to fund these obligations in subsequent years? (Remember to include compounding effects in meeting obligations.)

General Fund Unrestricted and Restricted Funds.

H. IMPACT OF PROPOSED AGREEMENT ON CURRENT YEAR OPERATING BUDGET

Santa Cruz City Schools		Unrestricted General Fund			
Bargaining Unit:		Greater Santa Cruz Federation of Teachers			
	Column 1	Column 2	Column 3	Column 4	
	Latest Board-Approved Budget Before Settlement (June 15, 2022)	Adjustments as a Result of Settlement	Other Revisions for Certificated AMA/Cabinet	Total Current Budget (Columns 1+2+3)	
REVENUES					
Local Control Funding Formula (8010-8099)	\$ 78,144,114.00	\$ -	\$ -	\$ 78,144,114.00	
Remaining Revenues (8100-8799)	\$ 8,176,384.00	\$ -	\$ 91,120.00	\$ 8,267,504.00	
TOTAL REVENUES	\$ 86,320,498.00	\$ -	\$ 91,120.00	\$ 86,411,618.00	
EXPENDITURES					
Certificated Salaries (1000-1999)	\$ 30,233,681.00	\$ 1,578,629.00	\$ 202,693.00	\$ 32,015,003.00	
Classified Salaries (2000-2999)	\$ 11,217,287.00	\$ -	\$ -	\$ 11,217,287.00	
Employee Benefits (3000-3999)	\$ 18,318,601.00	\$ 349,494.00	\$ 46,554.00	\$ 18,714,649.00	
Books and Supplies (4000-4999)	\$ 2,776,334.00	\$ -	\$ -	\$ 2,776,334.00	
Services, Other Operating Expenses (5000-5999)	\$ 7,268,955.00	\$ -	\$ -	\$ 7,268,955.00	
Capital Outlay (6000-6599)	\$ 168,946.00	\$ -	\$ -	\$ 168,946.00	
Other Outgo (7100-7299) (7400-7499)	\$ 25,362.00	\$ -	\$ -	\$ 25,362.00	
Direct Support/Indirect Cost (7300-7399)	\$ (1,087,801.00)	\$ -	\$ -	\$ (1,087,801.00)	
Other Adjustments					
TOTAL EXPENDITURES	\$ 68,921,365.00	\$ 1,928,123.00	\$ 249,247.00	\$ 71,098,735.00	
OPERATING SURPLUS (DEFICIT)	\$ 17,399,133.00	\$ (1,928,123.00)	\$ (158,127.00)	\$ 15,312,883.00	
TRANSFERS IN & OTHER SOURCES (8910-8979)	\$ 2,500,000.00	\$ -	\$ -	\$ 2,500,000.00	
TRANSFERS OUT & OTHER USES (7610-7699)	\$ 753,971.00			\$ 753,971.00	
CONTRIBUTIONS (8980-8999)	\$ (20,671,464.00)	\$ (642,707.00)	\$ (45,591.00)	\$ (21,359,762.00)	
CURRENT YEAR INCREASE (DECREASE) IN FUND BALANCE	\$ (1,526,302.00)	\$ (2,570,830.00)	\$ (203,718.00)	\$ (4,300,850.00)	
BEGINNING BALANCE					
Prior-Year Adjustments/Restatements (9793/9795)	\$ -			\$ -	
CURRENT-YEAR ENDING BALANCE	\$ 19,485,679.00	\$ (2,570,830.00)	\$ (203,718.00)	\$ 16,711,131.00	
COMPONENTS OF ENDING BALANCE:					
Nonspendable Amounts (9711-9739)	\$ 59,584.00	\$ -	\$ -	\$ 59,584.00	
Restricted Amounts (9740)	\$ -	\$ -	\$ -	\$ -	
Reserves for Economic Uncertainties (9789)	\$ 3,127,485.00	\$ 87,637.00		\$ 3,215,122.00	
Committed Amounts (9750-9760)	\$ 7,577,183.00	\$ 4,631,964.00		\$ 12,209,147.00	
Assigned Amounts (9780)	\$ -	\$ -	\$ -	\$ -	
Unassigned Amount (9790)	\$ 8,721,427.00	\$ (7,290,431.00)	\$ (203,718.00)	\$ 1,227,278.00	

* Please see question on page 7.

H. IMPACT OF PROPOSED AGREEMENT ON CURRENT YEAR OPERATING BUDGET

Santa Cruz City Schools

Restricted General Fund

Bargaining Unit:

Greater Santa Cruz Federation of Teachers

	Column 1	Column 2	Column 3	Column 4
	Latest Board-Approved Budget Before Settlement (June 15, 2022)	Adjustments as a Result of Settlement	Other Revisions for Certificated AMA	Total Current Budget (Columns 1+2+3)
REVENUES				
Local Control Funding Formula (8010-8099)	\$ -	\$ -	\$ -	\$ -
Remaining Revenues (8100-8799)	\$ 14,035,028.00	\$ -	\$ 55,547.00	\$ 14,090,575.00
TOTAL REVENUES	\$ 14,035,028.00	\$ -	\$ 55,547.00	\$ 14,090,575.00
EXPENDITURES				
Certificated Salaries (1000-1999)	\$ 8,948,977.00	\$ 526,210.00	\$ 37,076.00	\$ 9,512,263.00
Classified Salaries (2000-2999)	\$ 5,329,169.00	\$ -	\$ -	\$ 5,329,169.00
Employee Benefits (3000-3999)	\$ 11,027,166.00	\$ 116,497.00	\$ 8,515.00	\$ 11,152,178.00
Books and Supplies (4000-4999)	\$ 1,773,341.00	\$ -	\$ 55,547.00	\$ 1,828,888.00
Services, Other Operating Expenses (5000-5999)	\$ 6,171,581.00	\$ -	\$ -	\$ 6,171,581.00
Capital Outlay (6000-6599)	\$ 236,131.00	\$ -	\$ -	\$ 236,131.00
Other Outgo (7100-7299) (7400-7499)	\$ -	\$ -	\$ -	\$ -
Direct Support/Indirect Cost (7300-7399)	\$ 1,087,801.00	\$ -	\$ -	\$ 1,087,801.00
Other Adjustments				
TOTAL EXPENDITURES	\$ 34,574,166.00	\$ 642,707.00	\$ 101,138.00	\$ 35,318,011.00
OPERATING SURPLUS (DEFICIT)	\$ (20,539,138.00)	\$ (642,707.00)	\$ (45,591.00)	\$ (21,227,436.00)
TRANSFERS IN & OTHER SOURCES (8910-8979)	\$ -	\$ -	\$ -	\$ -
TRANSFERS OUT & OTHER USES (7610-7699)	\$ -	\$ -	\$ -	\$ -
CONTRIBUTIONS (8980-8999)	\$ 20,671,464.00	\$ 642,707.00	\$ 45,591.00	\$ 21,359,762.00
CURRENT YEAR INCREASE (DECREASE) IN FUND BALANCE	\$ 132,326.00	\$ -	\$ -	\$ 132,326.00
BEGINNING BALANCE	\$ 792,445.00			\$ 792,445.00
Prior-Year Adjustments/Restatements (9793/9795)	\$ -			\$ -
CURRENT-YEAR ENDING BALANCE	\$ 924,771.00	\$ -	\$ -	\$ 924,771.00
COMPONENTS OF ENDING BALANCE:				
Nonspendable Amounts (9711-9739)	\$ -	\$ -	\$ -	\$ -
Restricted Amounts (9740)	\$ 924,771.00	\$ -	\$ -	\$ 924,771.00
Committed Amounts (9750-9760)	\$ -	\$ -	\$ -	\$ -
Assigned Amounts (9775-9780)	\$ -	\$ -	\$ -	\$ -
Unassigned Amount (9790)				

* Please see question on page 7.

H. IMPACT OF PROPOSED AGREEMENT ON CURRENT YEAR OPERATING BUDGET

Santa Cruz City Schools		Combined General Fund		
Bargaining Unit:		Greater Santa Cruz Federation of Teachers		
	Column 1	Column 2	Column 3	Column 4
	Latest Board- Approved Budget Before Settlement (June 15, 2022)	Adjustments as a Result of Settlement	Other Revisions for Meet and Conf Groups	Total Current Budget (Columns 1+2+3)
REVENUES				
Local Control Funding Formula (8010-8099)	\$ 78,144,114.00	\$ -	\$ -	\$ 78,144,114.00
Remaining Revenues (8100-8799)	\$ 22,211,412.00	\$ -	\$ 146,667.00	\$ 22,358,079.00
TOTAL REVENUES	\$ 100,355,526.00	\$ -	\$ 146,667.00	\$ 100,502,193.00
EXPENDITURES				
Certificated Salaries (1000-1999)	\$ 39,182,658.00	\$ 2,104,839.00	\$ 239,769.00	\$ 41,527,266.00
Classified Salaries (2000-2999)	\$ 16,546,456.00	\$ -	\$ -	\$ 16,546,456.00
Employee Benefits (3000-3999)	\$ 29,345,767.00	\$ 465,991.00	\$ 55,069.00	\$ 29,866,827.00
Books and Supplies (4000-4999)	\$ 4,549,675.00	\$ -	\$ 55,547.00	\$ 4,605,222.00
Services, Other Operating Expenses (5000-5999)	\$ 13,440,536.00	\$ -	\$ -	\$ 13,440,536.00
Capital Outlay (6000-6599)	\$ 405,077.00	\$ -	\$ -	\$ 405,077.00
Other Outgo (7100-7299) (7400-7499)	\$ 25,362.00	\$ -	\$ -	\$ 25,362.00
Direct Support/Indirect Cost (7300-7399)	\$ -	\$ -	\$ -	\$ -
Other Adjustments				
TOTAL EXPENDITURES	\$ 103,495,531.00	\$ 2,570,830.00	\$ 350,385.00	\$ 106,416,746.00
OPERATING SURPLUS (DEFICIT)	\$ (3,140,005.00)	\$ (2,570,830.00)	\$ (203,718.00)	\$ (5,914,553.00)
TRANSFERS IN & OTHER SOURCES (8910-8979)	\$ 2,500,000.00	\$ -	\$ -	\$ 2,500,000.00
TRANSFERS OUT & OTHER USES (7610-7699)	\$ 753,971.00	\$ -	\$ -	\$ 753,971.00
CONTRIBUTIONS (8980-8999)	\$ -	\$ -	\$ -	\$ -
CURRENT YEAR INCREASE (DECREASE) IN FUND BALANCE	\$ (1,393,976.00)	\$ (2,570,830.00)	\$ (203,718.00)	\$ (4,168,524.00)
BEGINNING BALANCE	\$ 21,804,426.00			\$ 21,804,426.00
Prior-Year Adjustments/Restatements (9793/9795)	\$ -			\$ -
CURRENT-YEAR ENDING BALANCE	\$ 20,410,450.00	\$ (2,570,830.00)	\$ (203,718.00)	\$ 17,635,902.00
COMPONENTS OF ENDING BALANCE:				
Nonspendable Amounts (9711-9739)	\$ 59,584.00	\$ -	\$ -	\$ 59,584.00
Restricted Amounts (9740)	\$ 924,771.00	\$ -	\$ -	\$ 924,771.00
Reserves for Economic Uncertainties (9789)	\$ 3,127,485.00	\$ 87,637.00	\$ -	\$ 3,215,122.00
Committed Amounts (9750-9760)	\$ 7,577,183.00	\$ 4,631,964.00	\$ -	\$ 12,209,147.00
Assigned Amounts (9775-9780)	\$ -	\$ -	\$ -	\$ -
Unassigned Amount (9790)	\$ 8,721,427.00	\$ (7,290,431.00)	\$ (203,718.00)	\$ 1,227,278.00
Unassigned Amount - Restricted (9790)				
Reserve for Economic Uncertainties Percentage	11%			4%

* Please see question on page 7.

H. IMPACT OF PROPOSED AGREEMENT ON CURRENT YEAR OPERATING BUDGET

Cafeteria-Fund 13 and Building-Fund 21				
Greater Santa Cruz Federation of Teachers				
	Column 1	Column 2	Column 3	Column 4
	Latest Board- Approved Budget Before Settlement (June 15, 2022)	Adjustments as a Result of Settlement	Other Revisions for Classified AMA	Total Current Budget (Columns 1+2+3)
REVENUES				
Local Control Funding Formula (8010-8099)	\$ -			\$ -
Remaining Revenues (8100-8799)	\$ 1,908,702.00			\$ 1,908,702.00
TOTAL REVENUES	\$ 1,908,702.00	\$ -	\$ -	\$ 1,908,702.00
EXPENDITURES				
Certificated Salaries (1000-1999)	\$ -			\$ -
Classified Salaries (2000-2999)	\$ 1,300,123.05			\$ 1,300,123.05
Employee Benefits (3000-3999)	\$ 786,840.95			\$ 786,840.95
Books and Supplies (4000-4999)	\$ 815,631.00			\$ 815,631.00
Services, Other Operating Expenses (5000-5999)	\$ 57,255.00			\$ 57,255.00
Capital Outlay (6000-6599)	\$ 19,096,314.00			\$ 19,096,314.00
Other Outgo (7100-7299) (7400-7499)				\$ -
Direct Support/Indirect Cost (7300-7399)				\$ -
Other Adjustments				
TOTAL EXPENDITURES	\$ 22,056,164.00	\$ -	\$ -	\$ 22,056,164.00
OPERATING SURPLUS (DEFICIT)	\$ (20,147,462.00)	\$ -	\$ -	\$ (20,147,462.00)
TRANSFERS IN & OTHER SOURCES (8910-8979)	\$ 753,971.00			\$ 753,971.00
TRANSFERS OUT & OTHER USES (7610-7699)				\$ -
CONTRIBUTIONS (8980-8999)				\$ -
CURRENT YEAR INCREASE (DECREASE) IN FUND BALANCE	\$ (19,393,491.00)	\$ -	\$ -	\$ (19,393,491.00)
BEGINNING BALANCE	\$ 40,685,857.00			\$ 40,685,857.00
Prior-Year Adjustments/Restatements (9793/9795)				\$ -
CURRENT-YEAR ENDING BALANCE	\$ 21,292,366.00	\$ -	\$ -	\$ 21,292,366.00
COMPONENTS OF ENDING BALANCE:				
Nonspendable Amounts (9711-9739)				\$ -
Restricted Amounts (9740)	\$ 21,292,366.00			\$ 21,292,366.00
Reserves for Economic Uncertainties (9789)				\$ -
Committed Amounts (9750-9760)				\$ -
Assigned Amounts (9775-9780)				\$ -
Unassigned Amount (9790)	\$ -	\$ -	\$ -	\$ -
Unassigned Amount - Restricted (9790)				\$ -
Reserve for Economic Uncertainties Percentage				

* Please see question on page 7.

I. IMPACT OF PROPOSED AGREEMENT ON SUBSEQUENT YEARS

Santa Cruz City Schools

MYP - Unrestricted General Fund

Greater Santa Cruz Federation of Teachers

	2022-23	2023-24	2024-25
	Total Current Budget After Settlement	First Subsequent Year After Settlement	Second Subsequent Year After Settlement
REVENUES			
Local Control Funding Formula (8010-8099)	\$ 78,144,114.00	\$ 80,928,801.00	\$ 82,774,098.00
Remaining Revenues (8100-8799)	\$ 8,267,504.00	\$ 8,014,221.00	\$ 7,995,385.00
TOTAL REVENUES	\$ 86,411,618.00	\$ 88,943,022.00	\$ 90,769,483.00
EXPENDITURES			
Certificated Salaries (1000-1999)	\$ 32,015,003.00	\$ 32,184,187.00	\$ 32,659,656.00
Classified Salaries (2000-2999)	\$ 11,217,287.00	\$ 11,212,594.00	\$ 11,423,607.00
Employee Benefits (3000-3999)	\$ 18,714,649.00	\$ 19,428,890.00	\$ 20,198,579.00
Books and Supplies (4000-4999)	\$ 2,776,334.00	\$ 2,776,334.00	\$ 2,776,335.00
Services, Other Operating Expenses (5000-5999)	\$ 7,268,955.00	\$ 7,214,426.00	\$ 7,366,107.00
Capital Outlay (6000-6999)	\$ 168,946.00	\$ 168,946.00	\$ 168,946.00
Other Outgo (7100-7299) (7400-7499)	\$ 25,362.00	\$ 25,362.00	\$ 25,362.00
Direct Support/Indirect Cost (7300-7399)	\$ (1,087,801.00)	\$ (1,115,540.00)	\$ (1,143,986.00)
Other Adjustments		\$ -	\$ -
TOTAL EXPENDITURES	\$ 71,098,735.00	\$ 71,895,199.00	\$ 73,474,606.00
OPERATING SURPLUS (DEFICIT)	\$ 15,312,883.00	\$ 17,047,823.00	\$ 17,294,877.00
TRANSFERS IN & OTHER SOURCES (8910-8979)	\$ 2,500,000.00	\$ 2,500,000.00	\$ 2,500,000.00
TRANSFERS OUT & OTHER USES (7610-7699)	\$ 753,971.00	\$ 753,971.00	\$ 753,971.00
CONTRIBUTIONS (8980-8999)	\$ (21,359,762.00)	\$ (22,342,185.00)	\$ (22,829,712.00)
CURRENT YEAR INCREASE (DECREASE) IN FUND BALANCE	\$ (4,300,850.00)	\$ (3,548,333.00)	\$ (3,788,806.00)
BEGINNING BALANCE	\$ 21,011,981.00	\$ 16,711,131.00	\$ 13,162,798.00
CURRENT-YEAR ENDING BALANCE	\$ 16,711,131.00	\$ 13,162,798.00	\$ 9,373,992.00
COMPONENTS OF ENDING BALANCE:			
Nonspendable Amounts (9711-9739)	\$ 59,584.00	\$ 59,584.00	\$ 59,584.00
Restricted Amounts (9740)	\$ -	\$ -	\$ -
Reserves for Economic Uncertainties (9789)	\$ 3,215,122.00	\$ 3,146,027.00	\$ 3,208,001.00
Committed Amounts (9750-9760)	\$ 12,209,147.00	\$ 9,485,117.00	\$ 5,696,312.00
Assigned Amounts (9780)	\$ -	\$ -	\$ -
Unassigned Amount Unrestricted (9790)	\$ 1,227,278.00	\$ 472,070.00	\$ 410,095.00
Unassigned Amount - Restricted (9790)			

I. IMPACT OF PROPOSED AGREEMENT ON SUBSEQUENT YEARS

Santa Cruz City Schools

MYP - Restricted General Fund

Greater Santa Cruz Federation of Teachers

	2022-23	2023-24	2024-25
	Total Current Budget After Settlement	First Subsequent Year After Settlement	Second Subsequent Year After Settlement
REVENUES			
Local Control Funding Formula (8010-8099)	\$ -	\$ -	\$ -
Remaining Revenues (8100-8799)	\$ 14,090,575.00	\$ 9,891,271.00	\$ 9,891,271.00
TOTAL REVENUES	\$ 14,090,575.00	\$ 9,891,271.00	\$ 9,891,271.00
EXPENDITURES			
Certificated Salaries (1000-1999)	\$ 9,512,263.00	\$ 8,353,233.00	\$ 8,478,488.00
Classified Salaries (2000-2999)	\$ 5,329,169.00	\$ 4,209,365.00	\$ 4,293,409.00
Employee Benefits (3000-3999)	\$ 11,152,178.00	\$ 10,424,871.00	\$ 10,673,502.00
Books and Supplies (4000-4999)	\$ 1,828,888.00	\$ 1,707,687.00	\$ 1,707,687.00
Services, Other Operating Expenses (5000-5999)	\$ 6,171,581.00	\$ 6,171,581.00	\$ 6,171,581.00
Capital Outlay (6000-6999)	\$ 236,131.00	\$ 236,131.00	\$ 236,131.00
Other Outgo (7100-7299) (7400-7499)	\$ -	\$ -	\$ -
Direct Support/Indirect Cost (7300-7399)	\$ 1,087,801.00	\$ 1,115,540.00	\$ 1,143,986.00
Other Adjustments		\$ -	\$ -
TOTAL EXPENDITURES	\$ 35,318,011.00	\$ 32,218,408.00	\$ 32,704,784.00
OPERATING SURPLUS (DEFICIT)	\$ (21,227,436.00)	\$ (22,327,137.00)	\$ (22,813,513.00)
TRANSFERS IN & OTHER SOURCES (8910-8979)	\$ -	\$ -	\$ -
TRANSFERS OUT & OTHER USES (7610-7699)	\$ -	\$ -	\$ -
CONTRIBUTIONS (8980-8999)	\$ 21,359,762.00	\$ 22,342,185.00	\$ 22,829,712.00
CURRENT YEAR INCREASE (DECREASE) IN FUND BALANCE	\$ 132,326.00	\$ 15,048.00	\$ 16,199.00
BEGINNING BALANCE	\$ 792,445.00	\$ 924,771.00	\$ 939,819.00
CURRENT-YEAR ENDING BALANCE	\$ 924,771.00	\$ 939,819.00	\$ 956,018.00
COMPONENTS OF ENDING BALANCE:			
Nonspendable Amounts (9711-9739)	\$ -	\$ -	\$ -
Restricted Amounts (9740)	\$ 924,771.00	\$ 939,819.00	\$ 956,018.00
Reserves for Economic Uncertainties (9789)			
Committed Amounts (9750-9760)	\$ -	\$ -	\$ -
Assigned Amounts (9775-9780)	\$ -	\$ -	\$ -
Unassigned Amount Unrestricted (9790)			
Unassigned Amount - Restricted (9790)			

I. IMPACT OF PROPOSED AGREEMENT ON SUBSEQUENT YEARS

Santa Cruz City Schools

MYP - Combined General Fund

Greater Santa Cruz Federation of Teachers

	2022-23	2023-24	2024-25
	Total Current Budget After Settlement	First Subsequent Year After Settlement	Second Subsequent Year After Settlement
REVENUES			
Local Control Funding Formula (8010-8099)	\$ 78,144,114.00	\$ 80,928,801.00	\$ 82,774,098.00
Remaining Revenues (8100-8799)	\$ 22,358,079.00	\$ 17,905,492.00	\$ 17,886,656.00
TOTAL REVENUES	\$ 100,502,193.00	\$ 98,834,293.00	\$ 100,660,754.00
EXPENDITURES			
Certificated Salaries (1000-1999)	\$ 41,527,266.00	\$ 40,537,420.00	\$ 41,138,144.00
Classified Salaries (2000-2999)	\$ 16,546,456.00	\$ 15,421,959.00	\$ 15,717,016.00
Employee Benefits (3000-3999)	\$ 29,866,827.00	\$ 29,853,761.00	\$ 30,872,081.00
Books and Supplies (4000-4999)	\$ 4,605,222.00	\$ 4,484,021.00	\$ 4,484,022.00
Services, Other Operating Expenses (5000-5999)	\$ 13,440,536.00	\$ 13,386,007.00	\$ 13,537,688.00
Capital Outlay (6000-6999)	\$ 405,077.00	\$ 405,077.00	\$ 405,077.00
Other Outgo (7100-7299) (7400-7499)	\$ 25,362.00	\$ 25,362.00	\$ 25,362.00
Direct Support/Indirect Cost (7300-7399)	\$ -	\$ -	\$ -
Other Adjustments		\$ -	\$ -
TOTAL EXPENDITURES	\$ 106,416,746.00	\$ 104,113,607.00	\$ 106,179,390.00
OPERATING SURPLUS (DEFICIT)	\$ (5,914,553.00)	\$ (5,279,314.00)	\$ (5,518,636.00)
TRANSFERS IN & OTHER SOURCES (8910-8979)	\$ 2,500,000.00	\$ 2,500,000.00	\$ 2,500,000.00
TRANSFERS OUT & OTHER USES (7610-7699)	\$ 753,971.00	\$ 753,971.00	\$ 753,971.00
CURRENT YEAR INCREASE (DECREASE) IN FUND BALANCE	\$ (4,168,524.00)	\$ (3,533,285.00)	\$ (3,772,607.00)
BEGINNING BALANCE	\$ 21,804,426.00	\$ 17,635,902.00	\$ 14,102,617.00
CURRENT-YEAR ENDING BALANCE	\$ 17,635,902.00	\$ 14,102,617.00	\$ 10,330,010.00
COMPONENTS OF ENDING BALANCE:			
Nonspendable Amounts (9711-9739)	\$ 59,584.00	\$ 59,584	\$ 59,584
Restricted Amounts (9740)	\$ 924,771.00	\$ 939,819	\$ 956,018
Reserves for Economic Uncertainties (9789)	\$ 3,215,122.00	\$ 3,146,027	\$ 3,208,001
Committed Amounts (9750-9760)	\$ 12,209,147.00	\$ 9,485,117	\$ 5,696,312
Assigned Amounts (9775-9780)	\$ -	\$ -	\$ -
Unassigned Amount Unrestricted (9790)	\$ 1,227,278.00	\$ 472,070	\$ 410,095
Unassigned Amount - Restricted (9790)			

J. IMPACT OF PROPOSED AGREEMENT ON UNRESTRICTED RESERVES

1. State Reserve Standard

		2022-23	2023-24	2024-25
a.	Total Expenditures, Transfers Out, and Uses (Including Cost of Proposed Agreement)	\$ 107,170,717.00	\$ 104,867,578.00	\$ 106,933,361.00
b.	State Standard Minimum Reserve Percentage for this District:	3%	3%	3%
c.	State Standard Minimum Reserve Amount for this District (For districts with less than 1,001 ADA, this is the greater of Line a, times Line b. OR \$71,000.)	\$ 3,215,122	\$ 3,146,027	\$ 3,208,001

2. Budgeted **Unrestricted** Reserve (After Impact of Proposed Agreement)

a.	General Fund Budgeted Unrestricted Reserve for Economic Uncertainties (9789)	\$ 3,215,122.00	\$ 3,146,027.00	\$ 3,208,001.00
b.	General Fund Budgeted Unrestricted Unassigned Amount (9790)	\$ 1,227,278.00	\$ 472,070.00	\$ 410,095.00
c.	Special Reserve Fund (Fund 17) Budgeted Reserves for Economic Uncertainties (9789)	\$ -	\$ -	\$ -
d.	Special Reserve Fund (Fund 17) Budgeted Unassigned Amount (9790)	\$ -	\$ -	\$ -
g.	Total Available Reserves	\$ 4,442,400.00	\$ 3,618,097.00	\$ 3,618,096.00
h.	Reserve for Economic Uncertainties Percentage	4.15%	3.45%	3.38%

3. Do unrestricted reserves meet the state minimum reserve amount?

2022-23	Yes	<input checked="" type="checkbox"/>	No	<input type="checkbox"/>
2023-24	Yes	<input checked="" type="checkbox"/>	No	<input type="checkbox"/>
2024-25	Yes	<input checked="" type="checkbox"/>	No	<input type="checkbox"/>

4. If not, how do you plan to restore your reserves?

5. If the total amount of the adjustment in Column 2 on Page 4c does not agree with the amount of the Total Compensation Increase in Section A, Line 5, Page 1 (i.e., increase was partially budgeted), explain the variance below:

The difference of \$642,707 is the amount of the contribution to the Restricted General Fund.

6. Please include any additional comments and explanations of Page 4 as necessary or any other information that you want to provide to assist us in our analysis.

L. CERTIFICATION NO. 1: CERTIFICATION OF THE DISTRICT'S ABILITY TO MEET THE COSTS OF COLLECTIVE BARGAINING AGREEMENT

The disclosure document must be signed by the district Superintendent and Chief Business Officer at the time of public disclosure.

In accordance with the requirements of Government Code Section 3547.5, the Superintendent and Chief Business Officer of Santa Cruz City Schools (District), hereby certify that the District can meet the costs incurred under the Collective Bargaining Agreement between the District and the Greater Santa Cruz Federation of Teachers Bargaining Unit, during the term of the agreement from July 1, 2022 to June 30, 2025.

The budget revisions necessary to meet the costs of the agreement in each year of its term are as follows:

<u>Budget Adjustment Categories:</u>	<u>Budget Adjustment Increase (Decrease)</u>
<u>Unrestricted Revenues/Other Financing Sources</u>	\$ (642,707.00)
<u>Unrestricted Expenditures/Other Financing Uses</u>	\$ 1,928,123.00
<u>Unrestricted Ending Balance Increase (Decrease)</u>	<u>\$ (2,570,830.00)</u>
<u>Restricted Revenues/Other Financing Sources</u>	\$ 642,707.00
<u>Restricted Expenditures/Other Financing Uses</u>	\$ 642,707.00
<u>Restricted Ending Balance Increase (Decrease)</u>	<u>\$ -</u>

N/A ____ (No budget revisions necessary)

District Superintendent
 (Signature)

Date

Chief Business Officer
 (Signature)

Date

M. CERTIFICATION NO. 2

The disclosure document must be signed by the district Superintendent or designee at the time of public disclosure and by the President or Clerk of the Governing Board at the time of formal board action on the proposed agreement.

The information provided in this document summarizes the financial implications of the proposed agreement and is submitted to the Governing Board for public disclosure of the major provisions of the agreement (as provided in the "Public Disclosure of Proposed Bargaining Agreement") in accordance with the requirements of AB 1200 and Government Code Section 3547.5.

District Superintendent (or Designee)
(Signature)

Date

Jim Monreal, Assistant Superintendent of Business Services
Contact Person

(831) 429-3410 x48224
Phone

After public disclosure of the major provisions contained in this summary, the Governing Board at its meeting on August 17, 2022, took action to approve the proposed Agreement with the Greater Santa Cruz Federation of Teachers Bargaining Unit.

President (or Clerk), Governing Board
(Signature)

Date

Special Note: The Santa Cruz County Office of Education may request additional information, as necessary, to review the district's compliance with requirements.

SANTA CRUZ CITY SCHOOL DISTRICT

AGENDA ITEM: AB 1200 Public Disclosure on Tentative 2022-23 Collective Bargaining Agreement, between Santa Cruz City Schools and the Santa Cruz Council of Classified Employees (SCCCE)

MEETING DATE: August 17, 2022

FROM: Jim Monreal, Assistant Superintendent, Business Services

THROUGH: Kris Munro, Superintendent

RECOMMENDATION:

Approve AB 1200 Public Disclosure on tentative bargaining agreement with Santa Cruz Council of Classified Employees for 2022-23.

BACKGROUND:

A tentative bargaining agreement for 2022-23 has been reached with the District's classified bargaining unit, the Santa Cruz Council of Classified Employees. The Board is required by AB 1200 to make this tentative agreement available to the public, to publicly disclose its costs.

The proposed agreement for 2022-23 will provide a 5% increase on the classified salary schedule, starting July 1, 2022.

A one-time off salary schedule payment of \$1,250 for FTE .51 to 1.00 (+) FTE and \$625 for FTE of .50 or below for 2022-23.

FISCAL IMPACT:

- A recurring annual cost of \$1,044,739
- A one-time cost of \$438,879

Funding Sources: LCFF Base (Unrestricted), LCFF Supplemental (Restricted), Federal Categorical Programs (Restricted), State and Local Funds (Restricted and Unrestricted).

This work is in direct support of the following District goals and their corresponding metrics:

Goal #5: SCCS will maintain a balanced budget and efficient and effective management.

Goal #6: SCCS will maintain strong communication and partnership with its diverse community.

AGENDA ITEM: 8.5.2.3.

L. CERTIFICATION NO. 1: CERTIFICATION OF THE DISTRICT'S ABILITY TO MEET THE COSTS OF COLLECTIVE BARGAINING AGREEMENT

The disclosure document must be signed by the district Superintendent and Chief Business Officer at the time of public disclosure.

In accordance with the requirements of Government Code Section 3547.5, the Superintendent and Chief Business Officer of Santa Cruz City Schools (District), hereby certify that the District can meet the costs incurred under the Collective Bargaining Agreement between the District and the Santa Cruz Council of Classified Employees Bargaining Unit, during the term of the agreement from July 1, 2022 to June 30, 2025.

The budget revisions necessary to meet the costs of the agreement in each year of its term are as follows:

<u>Budget Adjustment Categories:</u>	<u>Budget Adjustment Increase (Decrease)</u>
<u>Unrestricted Revenues/Other Financing Sources</u>	<u>\$ (429,758.00)</u>
<u>Unrestricted Expenditures/Other Financing Uses</u>	<u>\$ 798,121.00</u>
<u>Unrestricted Ending Balance Increase (Decrease)</u>	<u>\$ (1,319,965.00)</u>
<u>Restricted Revenues/Other Financing Sources</u>	<u>\$ 429,758.00</u>
<u>Restricted Expenditures/Other Financing Uses</u>	<u>\$ 429,758.00</u>
<u>Restricted Ending Balance Increase (Decrease)</u>	<u>\$ -</u>

N/A (No budget revisions necessary)



District Superintendent
(Signature)

8/4/22

Date



Chief Business Officer
(Signature)

8/4/22

Date

L. CERTIFICATION NO. 1: CERTIFICATION OF THE DISTRICT'S ABILITY TO MEET THE COSTS OF COLLECTIVE BARGAINING AGREEMENT

The disclosure document must be signed by the district Superintendent and Chief Business Officer at the time of public disclosure.

In accordance with the requirements of Government Code Section 3547.5, the Superintendent and Chief Business Officer of Santa Cruz City Schools (District), hereby certify that the District can meet the costs incurred under the Collective Bargaining Agreement between the District and the Greater Santa Cruz Federation of Teachers Bargaining Unit, during the term of the agreement from July 1, 2022 to June 30, 2025.

The budget revisions necessary to meet the costs of the agreement in each year of its term are as follows:

<u>Budget Adjustment Categories:</u>	<u>Budget Adjustment Increase (Decrease)</u>
<u>Unrestricted Revenues/Other Financing Sources</u>	<u>\$ 642,707.00</u>
<u>Unrestricted Expenditures/Other Financing Uses</u>	<u>\$ 1,928,123.00</u>
<u>Unrestricted Ending Balance Increase (Decrease)</u>	<u>\$ (2,570,830.00)</u>
<u>Restricted Revenues/Other Financing Sources</u>	<u>\$ 642,707.00</u>
<u>Restricted Expenditures/Other Financing Uses</u>	<u>\$ 642,707.00</u>
<u>Restricted Ending Balance Increase (Decrease)</u>	<u>\$ -</u>

N/A ____ (No budget revisions necessary)



 District Superintendent
 (Signature)

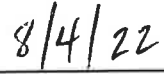

 Date



 Chief Business Officer
 (Signature)

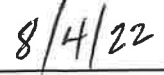

 Date

Government Code - GOV

TITLE 1. GENERAL [100 - 7914]

(Title 1 enacted by Stats. 1943, Ch. 134.)

DIVISION 4. PUBLIC OFFICERS AND EMPLOYEES [1000 - 3599]

(Division 4 enacted by Stats. 1943, Ch. 134.)

CHAPTER 10.7. Meeting and Negotiating in Public Educational Employment [3540 - 3549.3]

(Chapter 10.7 added by Stats. 1975, Ch. 961.)

ARTICLE 8. Public Notice [3547 - 3547.5]

(Article 8 added by Stats. 1975, Ch. 961.)

PUBLIC DISCLOSURE OF COLLECTIVE BARGAINING AGREEMENT

3547.5.

(a) Before a public school employer enters into a written agreement with an exclusive representative covering matters within the scope of representation, the major provisions of the agreement, including, but not limited to, the costs that would be incurred by the public school employer under the agreement for the current and subsequent fiscal years, shall be disclosed at a public meeting of the public school employer in a format established for this purpose by the Superintendent of Public Instruction.

(b) The superintendent of the school district and chief business official shall certify in writing that the costs incurred by the school district under the agreement can be met by the district during the term of the agreement. This certification shall be prepared in a format similar to that of the reports required pursuant to Sections 42130 and 42131 of the Education Code and shall itemize any budget revision necessary to meet the costs of the agreement in each year of its term.

(c) If a school district does not adopt all of the revisions to its budget needed in the current fiscal year to meet the costs of a collective bargaining agreement, the county superintendent of schools shall issue a qualified or negative certification for the district on the next interim report pursuant to Section 42131 of the Education Code.

(Amended by Stats. 2004, Ch. 52, Sec. 17. Effective June 21, 2004.)

COE NOTE:

NOTE: A Side letter – not ratified by union membership – does not require a public disclosure or to go to board, unless it has a fiscal impact.

Santa Cruz County Office of Education
Business Services Division

Public Disclosure of Collective Bargaining Agreement (AB1200 Form)

This Excel form should be sent to the COE at least 10 calendar days prior to the District's Board meeting that will have a compensation settlement between the district and a bargaining unit as an agenda item.

Please email the form, TA and other supporting documentation to:

coe_business_help@santacruzcoe.org

For additional information concerning this document and process, please contact Jean Gardner, at (831) 466-5604 or by email at:

jgardner@santacruzcoe.org

The timing between union ratification and the AB1200 deadline is not as critical; just need to submit at least 10 days prior to the public meeting where the disclosure will be discussed.

Government Code 3547.5

This full packet must be included in board packet, and a PUBLIC meeting must be held. (not a public hearing)

The disclosure of major provisions and cost comes first, 2nd Item the board approves the agreement/ratification.

Probably advisable to post full disclosure with announcement of/posting of Agenda.

Include all costs in ALL FUNDS on page 1, even if they are already budgeted.
only complete the year 2 and year 3 column if the agreement in a multi-year agreement.
if it's a one year agreement, even if ongoing costs, do not include costs in those columns.
for HW increases, the year ends 9/30 so costs would be included in year 2.

COE Website link to most recent form:

http://www.santacruzcoe.org/business/dist_support_services/forms.html

Form updated: 3/21/2019

**Santa Cruz County Office of Education
Business Services Department**

**PUBLIC DISCLOSURE OF COLLECTIVE BARGAINING AGREEMENT
in Accordance with AB 1200 (Chapter 1213/1991), GC 3547.5, and CCR, Title V, Section 15449**

Name of School District: Santa Cruz City Schools
 Name of Bargaining Unit: Santa Cruz Council of Classified Employees
 Certificated or Classified: Classified

The proposed agreement covers the period beginning: July 1, 2022 and ending: June 30, 2023
 (date) (date)

The Governing Board will act upon this agreement on: August 17, 2022
 (date)

Note: This form, along with a copy of the proposed agreement, must be submitted to the county office at least ten (10) working days prior to the date the governing board will take action.

A. Proposed Change in Compensation

Compensation	Annual Cost Prior to Proposed Agreement FY 2022-23	Fiscal Impact of Proposed Agreement		
		Year 1 Increase/(Decrease) FY 2022-23	Year 2 Increase/(Decrease) FY	Year 3 Increase/(Decrease) FY
1 Salary Schedule Increase (Decrease)	\$13,685,275	\$684,264		
		5.00%	0.00%	0.00%
2 Step and Column - Increase (Decrease) Due to movement plus any changes due to settlement				
		0.00%	0.00%	0.00%
3 Other Compensation - Increase (Decrease)(Stipends, Bonuses, Longevity, Overtime, etc.) **Included in base above		\$338,750		
Description of other compensation: \$1,250 Bonus for FTE above 0.51 and \$625 bonus for FTE 0.50 to .10				
4 Statutory Benefits - STRS, PERS, FICA, WC, UI, Medicate etc.	\$4,480,709	\$301,136		
		6.72%	0.00%	0.00%
5 Health/Welfare Plans	\$5,757,900	\$0		
		0.00%	0.00%	0.00%
6 Total Compensation - Increase (Decrease) (Total Lines 1-5)	\$23,923,884	\$1,324,150	\$0	\$0
7 Total Number of Represented Employees (Use FTEs if appropriate)	281.28			
8 Total Compensation Average Cost per Employee	\$ 85,053.02	\$ 4,707.55	\$ -	\$ -
		5.53%	0.00%	0.00%

9. What was the negotiated percentage increase approved? For example, if the increase in "Year 1" was for less than a full year, what is the annualized percentage of that increase for "Year 1"?

For 2022-23 the District and SCCCE agreed to a 5.00% retroactive on the salary schedule increase. The salary increase will be retroactive to July 1, 2022. In addition to the 5% a one-time off the salary schedule payment of \$1,250 will be paid to employees 0.51 FTE and above. A one-time off the salary schedule payment of \$625 will be paid to employees 0.50 FTE and below. This one-time off the salary schedule payment will be paid to employees in permanent status as of the first day of school August 10, 2022, and must be in employed status on the date of distribution of payment.

10. Were any additional steps, columns, or ranges added to the schedules? (If yes, please explain.)

None

11. Please include comments and explanations as necessary.

The 5% salary schedule increase for 2022-23 and the one-time bonus off the schedule will close out the 2021-22 negotiations.

12. Does this bargaining unit have a negotiated cap for Health and Welfare benefits? Yes No

If yes, please describe the cap amount.

Classified BU has a hard cap at Blue Shield HMO \$25 Office/\$500 Hospital plan rates, district picks up 70% of increases and employee picks up 30%. All other classified plans is 100% employee portion if the premium cost is more than the cap.

B. Proposed Negotiated Changes in Noncompensation Items (i.e., class size adjustments, etc.)

None

C. What are the specific impacts on instructional and support programs to accommodate the settlement?

Please indicate the status of these changes: 1) planning stage, 2) in-progress, or 3) adopted. Include the impact of changes such as staff reductions or increases, program reductions or increases, elimination or expansion of other services or programs (i.e., counselors, librarians, custodial staff, etc.)

None

D. What contingency language is included in the proposed agreement? Include specific areas identified reopeners, applicable fiscal years, and specific contingency language.

None

E. Will this agreement create, increase or decrease deficit spending in the current or subsequent year(s)? "Deficit spending" is defined to exist when a fund's expenditures and other financing uses exceed its revenues and other financing sources in a given year. If yes, explain the amounts and justification for doing so.

Yes, this will increase the deficit spending and the district does have a reserve over the 3% minimum to cover these costs.

F. Describe other major provisions that do not directly affect the district's costs, such as binding arbitrations, grievance procedures, etc. Please disclose any other components of the agreement which may or may not affect the district's fund balance in future years.

None

G. Source of Funding for Proposed Agreement

1. Current Year

General Fund Unrestricted, Restricted Funds, Food Service and Bond Funds.

2. If this is a single year agreement, how will the on-going cost of the proposed agreement be funded in subsequent years (i.e., what will allow the district to afford this contract)?

3. If this is a multiyear agreement, what is the source of funding, including assumptions used, to fund these obligations in subsequent years? (Remember to include compounding effects in meeting obligations.)

General Fund Unrestricted, Restricted Funds, Food Service and Bond Funds.

H. IMPACT OF PROPOSED AGREEMENT ON CURRENT YEAR OPERATING BUDGET

Santa Cruz City Schools		Unrestricted General Fund			
Bargaining Unit:		Santa Cruz Council of Classified Employees			
	Column 1	Column 2	Column 3	Column 4	
	Latest Board-Approved Budget Before Settlement (June 15, 2022)	Adjustments as a Result of Settlement	Other Revisions for Classified AMA/Cabinet/Conf	Total Current Budget (Columns 1+2+3)	
REVENUES					
Local Control Funding Formula (8010-8099)	\$ 78,144,114.00	\$ -	\$ -	\$ 78,144,114.00	
Remaining Revenues (8100-8799)	\$ 8,176,384.00	\$ -	\$ -	\$ 8,176,384.00	
TOTAL REVENUES	\$ 86,320,498.00	\$ -	\$ -	\$ 86,320,498.00	
EXPENDITURES					
Certificated Salaries (1000-1999)	\$ 30,233,681.00	\$ -	\$ -	\$ 30,233,681.00	
Classified Salaries (2000-2999)	\$ 10,517,992.00	\$ 617,598.00	\$ 81,697.00	\$ 11,217,287.00	
Employee Benefits (3000-3999)	\$ 18,109,125.00	\$ 180,523.00	\$ 28,953.00	\$ 18,318,601.00	
Books and Supplies (4000-4999)	\$ 2,776,334.00	\$ -	\$ -	\$ 2,776,334.00	
Services, Other Operating Expenses (5000-5999)	\$ 7,268,955.00	\$ -	\$ -	\$ 7,268,955.00	
Capital Outlay (6000-6599)	\$ 168,946.00	\$ -	\$ -	\$ 168,946.00	
Other Outgo (7100-7299) (7400-7499)	\$ 25,362.00	\$ -	\$ -	\$ 25,362.00	
Direct Support/Indirect Cost (7300-7399)	\$ (1,087,801.00)	\$ -	\$ -	\$ (1,087,801.00)	
Other Adjustments					
TOTAL EXPENDITURES	\$ 68,012,594.00	\$ 798,121.00	\$ 110,650.00	\$ 68,921,365.00	
OPERATING SURPLUS (DEFICIT)	\$ 18,307,904.00	\$ (798,121.00)	\$ (110,650.00)	\$ 17,399,133.00	
TRANSFERS IN & OTHER SOURCES (8910-8979)	\$ 2,500,000.00	\$ -	\$ -	\$ 2,500,000.00	
TRANSFERS OUT & OTHER USES (7610-7699)	\$ 650,696.00	\$ 92,086.00	\$ 11,189.00	\$ 753,971.00	
CONTRIBUTIONS (8980-8999)	\$ (20,221,721.00)	\$ (429,758.00)	\$ (19,985.00)	\$ (20,671,464.00)	
CURRENT YEAR INCREASE (DECREASE) IN FUND BALANCE	\$ (64,513.00)	\$ (1,319,965.00)	\$ (141,824.00)	\$ (1,526,302.00)	
BEGINNING BALANCE					
Prior-Year Adjustments/Restatements (9793/9795)	\$ -			\$ -	
CURRENT-YEAR ENDING BALANCE	\$ 20,428,807.00	\$ (1,319,965.00)	\$ (141,824.00)	\$ 18,967,018.00	
COMPONENTS OF ENDING BALANCE:					
Nonspendable Amounts (9711-9739)	\$ 59,584.00	\$ -	\$ -	\$ 59,584.00	
Restricted Amounts (9740)	\$ -	\$ -	\$ -	\$ -	
Reserves for Economic Uncertainties (9789)	\$ 3,083,631.00	\$ 39,599.00	\$ 4,255.00	\$ 3,127,485.00	
Committed Amounts (9750-9760)	\$ 5,355,443.00	\$ 1,970,654.00	\$ 251,086.00	\$ 7,577,183.00	
Assigned Amounts (9780)	\$ -	\$ -	\$ -	\$ -	
Unassigned Amount (9790)	\$ 11,930,149.00	\$ (3,330,218.00)	\$ (397,165.00)	\$ 8,202,766.00	

* Please see question on page 7.

H. IMPACT OF PROPOSED AGREEMENT ON CURRENT YEAR OPERATING BUDGET

Santa Cruz City Schools

Restricted General Fund

Bargaining Unit:

Santa Cruz Council of Classified Employees

	Column 1	Column 2	Column 3	Column 4
	Latest Board-Approved Budget Before Settlement (June 15, 2022)	Adjustments as a Result of Settlement	Other Revisions for Classified AMA	Total Current Budget (Columns 1+2+3)
REVENUES				
Local Control Funding Formula (8010-8099)	\$ -	\$ -	\$ -	\$ -
Remaining Revenues (8100-8799)	\$ 14,035,028.00	\$ -	\$ -	\$ 14,035,028.00
TOTAL REVENUES	\$ 14,035,028.00	\$ -	\$ -	\$ 14,035,028.00
EXPENDITURES				
Certificated Salaries (1000-1999)	\$ 8,948,977.00	\$ -	\$ -	\$ 8,948,977.00
Classified Salaries (2000-2999)	\$ 4,981,860.00	\$ 332,553.00	\$ 14,756.00	\$ 5,329,169.00
Employee Benefits (3000-3999)	\$ 10,924,732.00	\$ 97,205.00	\$ 5,229.00	\$ 11,027,166.00
Books and Supplies (4000-4999)	\$ 1,773,341.00	\$ -	\$ -	\$ 1,773,341.00
Services, Other Operating Expenses (5000-5999)	\$ 6,171,581.00	\$ -	\$ -	\$ 6,171,581.00
Capital Outlay (6000-6599)	\$ 236,131.00	\$ -	\$ -	\$ 236,131.00
Other Outgo (7100-7299) (7400-7499)	\$ -	\$ -	\$ -	\$ -
Direct Support/Indirect Cost (7300-7399)	\$ 1,087,801.00	\$ -	\$ -	\$ 1,087,801.00
Other Adjustments				
TOTAL EXPENDITURES	\$ 34,124,423.00	\$ 429,758.00	\$ 19,985.00	\$ 34,574,166.00
OPERATING SURPLUS (DEFICIT)	\$ (20,089,395.00)	\$ (429,758.00)	\$ (19,985.00)	\$ (20,539,138.00)
TRANSFERS IN & OTHER SOURCES (8910-8979)	\$ -	\$ -	\$ -	\$ -
TRANSFERS OUT & OTHER USES (7610-7699)	\$ -	\$ -	\$ -	\$ -
CONTRIBUTIONS (8980-8999)	\$ 20,221,721.00	\$ 429,758.00	\$ 19,985.00	\$ 20,671,464.00
CURRENT YEAR INCREASE (DECREASE) IN FUND BALANCE	\$ 132,326.00	\$ -	\$ -	\$ 132,326.00
BEGINNING BALANCE	\$ 792,445.00			\$ 792,445.00
Prior-Year Adjustments/Restatements (9793/9795)	\$ -			\$ -
CURRENT-YEAR ENDING BALANCE	\$ 924,771.00	\$ -	\$ -	\$ 924,771.00
COMPONENTS OF ENDING BALANCE:				
Nonspendable Amounts (9711-9739)	\$ -	\$ -	\$ -	\$ -
Restricted Amounts (9740)	\$ 924,771.00	\$ -	\$ -	\$ 924,771.00
Committed Amounts (9750-9760)	\$ -	\$ -	\$ -	\$ -
Assigned Amounts (9775-9780)	\$ -	\$ -	\$ -	\$ -
Unassigned Amount (9790)				

* Please see question on page 7.

H. IMPACT OF PROPOSED AGREEMENT ON CURRENT YEAR OPERATING BUDGET

Santa Cruz City Schools		Combined General Fund		
Bargaining Unit:		Santa Cruz Council of Classified Employees		
	Column 1	Column 2	Column 3	Column 4
	Latest Board- Approved Budget Before Settlement (June 15, 2022)	Adjustments as a Result of Settlement	Other Revisions for Meet and Conf Groups	Total Current Budget (Columns 1+2+3)
REVENUES				
Local Control Funding Formula (8010-8099)	\$ 78,144,114.00	\$ -	\$ -	\$ 78,144,114.00
Remaining Revenues (8100-8799)	\$ 22,211,412.00	\$ -	\$ -	\$ 22,211,412.00
TOTAL REVENUES	\$ 100,355,526.00	\$ -	\$ -	\$ 100,355,526.00
EXPENDITURES				
Certificated Salaries (1000-1999)	\$ 39,182,658.00	\$ -	\$ -	\$ 39,182,658.00
Classified Salaries (2000-2999)	\$ 15,499,852.00	\$ 950,151.00	\$ 96,453.00	\$ 16,546,456.00
Employee Benefits (3000-3999)	\$ 29,033,857.00	\$ 277,728.00	\$ 34,182.00	\$ 29,345,767.00
Books and Supplies (4000-4999)	\$ 4,549,675.00	\$ -	\$ -	\$ 4,549,675.00
Services, Other Operating Expenses (5000-5999)	\$ 13,440,536.00	\$ -	\$ -	\$ 13,440,536.00
Capital Outlay (6000-6599)	\$ 405,077.00	\$ -	\$ -	\$ 405,077.00
Other Outgo (7100-7299) (7400-7499)	\$ 25,362.00	\$ -	\$ -	\$ 25,362.00
Direct Support/Indirect Cost (7300-7399)	\$ -	\$ -	\$ -	\$ -
Other Adjustments				
TOTAL EXPENDITURES	\$ 102,137,017.00	\$ 1,227,879.00	\$ 130,635.00	\$ 103,495,531.00
OPERATING SURPLUS (DEFICIT)	\$ (1,781,491.00)	\$ (1,227,879.00)	\$ (130,635.00)	\$ (3,140,005.00)
TRANSFERS IN & OTHER SOURCES (8910-8979)	\$ 2,500,000.00	\$ -	\$ -	\$ 2,500,000.00
TRANSFERS OUT & OTHER USES (7610-7699)	\$ 650,696.00	\$ 92,086.00	\$ 11,189.00	\$ 753,971.00
CONTRIBUTIONS (8980-8999)	\$ -	\$ -	\$ -	\$ -
CURRENT YEAR INCREASE (DECREASE) IN FUND BALANCE	\$ 67,813.00	\$ (1,319,965.00)	\$ (141,824.00)	\$ (1,393,976.00)
BEGINNING BALANCE				
Prior-Year Adjustments/Restatements (9793/9795)	\$ -			\$ -
CURRENT-YEAR ENDING BALANCE	\$ 21,353,578.00	\$ (1,319,965.00)	\$ (141,824.00)	\$ 19,891,789.00
COMPONENTS OF ENDING BALANCE:				
Nonspendable Amounts (9711-9739)	\$ 59,584.00	\$ -	\$ -	\$ 59,584.00
Restricted Amounts (9740)	\$ 924,771.00	\$ -	\$ -	\$ 924,771.00
Reserves for Economic Uncertainties (9789)	\$ 3,083,631.00	\$ 39,599.00	\$ 4,255.00	\$ 3,127,485.00
Committed Amounts (9750-9760)	\$ 5,355,443.00	\$ 1,970,654.00	\$ 251,086.00	\$ 7,577,183.00
Assigned Amounts (9775-9780)	\$ -	\$ -	\$ -	\$ -
Unassigned Amount (9790)	\$ 11,930,149.00	\$ (3,330,218.00)	\$ (397,165.00)	\$ 8,202,766.00
Unassigned Amount - Restricted (9790)				
Reserve for Economic Uncertainties Percentage	15%			11%

* Please see question on page 7.

H. IMPACT OF PROPOSED AGREEMENT ON CURRENT YEAR OPERATING BUDGET

Cafeteria-Fund 13 and Building-Fund 21				
Santa Cruz Council of Classified Employees				
	Column 1	Column 2	Column 3	Column 4
	Latest Board- Approved Budget Before Settlement (June 15, 2022)	Adjustments as a Result of Settlement	Other Revisions for Classified AMA	Total Current Budget (Columns 1+2+3)
REVENUES				
Local Control Funding Formula (8010-8099)	\$ -			\$ -
Remaining Revenues (8100-8799)	\$ 1,908,702.00			\$ 1,908,702.00
TOTAL REVENUES	\$ 1,908,702.00	\$ -	\$ -	\$ 1,908,702.00
EXPENDITURES				
Certificated Salaries (1000-1999)	\$ -			\$ -
Classified Salaries (2000-2999)	\$ 1,205,971.05	\$ 72,863.00	\$ 21,289.00	\$ 1,300,123.05
Employee Benefits (3000-3999)	\$ 755,888.95	\$ 23,408.00	\$ 7,544.00	\$ 786,840.95
Books and Supplies (4000-4999)	\$ 815,631.00			\$ 815,631.00
Services, Other Operating Expenses (5000-5999)	\$ 57,255.00			\$ 57,255.00
Capital Outlay (6000-6599)	\$ 19,118,143.00	\$ (4,185.00)	\$ (17,644.00)	\$ 19,096,314.00
Other Outgo (7100-7299) (7400-7499)				\$ -
Direct Support/Indirect Cost (7300-7399)				\$ -
Other Adjustments				
TOTAL EXPENDITURES	\$ 21,952,889.00	\$ 92,086.00	\$ 11,189.00	\$ 22,056,164.00
OPERATING SURPLUS (DEFICIT)	\$ (20,044,187.00)	\$ (92,086.00)	\$ (11,189.00)	\$ (20,147,462.00)
TRANSFERS IN & OTHER SOURCES (8910-8979)	\$ 650,696.00	\$ 92,086.00	\$ 11,189.00	\$ 753,971.00
TRANSFERS OUT & OTHER USES (7610-7699)				\$ -
CONTRIBUTIONS (8980-8999)				\$ -
CURRENT YEAR INCREASE (DECREASE) IN FUND BALANCE	\$ (19,393,491.00)	\$ -	\$ -	\$ (19,393,491.00)
BEGINNING BALANCE	\$ 40,685,857.00			\$ 40,685,857.00
Prior-Year Adjustments/Restatements (9793/9795)				\$ -
CURRENT-YEAR ENDING BALANCE	\$ 21,292,366.00	\$ -	\$ -	\$ 21,292,366.00
COMPONENTS OF ENDING BALANCE:				
Nonspendable Amounts (9711-9739)				\$ -
Restricted Amounts (9740)	\$ 21,292,366.00			\$ 21,292,366.00
Reserves for Economic Uncertainties (9789)				\$ -
Committed Amounts (9750-9760)				\$ -
Assigned Amounts (9775-9780)				\$ -
Unassigned Amount (9790)	\$ -	\$ -	\$ -	\$ -
Unassigned Amount - Restricted (9790)				\$ -
Reserve for Economic Uncertainties Percentage				

* Please see question on page 7.

I. IMPACT OF PROPOSED AGREEMENT ON SUBSEQUENT YEARS

Santa Cruz City Schools

MYP - Unrestricted General Fund

Santa Cruz Council of Classified Employees

	2022-23	2023-24	2024-25
	Total Current Budget After Settlement	First Subsequent Year After Settlement	Second Subsequent Year After Settlement
REVENUES			
Local Control Funding Formula (8010-8099)	\$ 78,144,114.00	\$ 80,928,801.00	\$ 82,774,098.00
Remaining Revenues (8100-8799)	\$ 8,176,384.00	\$ 7,905,653.00	\$ 7,873,085.00
TOTAL REVENUES	\$ 86,320,498.00	\$ 88,834,454.00	\$ 90,647,183.00
EXPENDITURES			
Certificated Salaries (1000-1999)	\$ 30,233,681.00	\$ 30,674,135.00	\$ 31,126,954.00
Classified Salaries (2000-2999)	\$ 11,217,287.00	\$ 11,212,594.00	\$ 11,423,607.00
Employee Benefits (3000-3999)	\$ 18,318,601.00	\$ 19,105,606.00	\$ 19,878,512.00
Books and Supplies (4000-4999)	\$ 2,776,334.00	\$ 2,776,334.00	\$ 2,776,335.00
Services, Other Operating Expenses (5000-5999)	\$ 7,268,955.00	\$ 7,214,426.00	\$ 7,366,107.00
Capital Outlay (6000-6999)	\$ 168,946.00	\$ 168,946.00	\$ 168,946.00
Other Outgo (7100-7299) (7400-7499)	\$ 25,362.00	\$ 25,362.00	\$ 25,362.00
Direct Support/Indirect Cost (7300-7399)	\$ (1,087,801.00)	\$ (1,115,540.00)	\$ (1,143,986.00)
Other Adjustments		\$ -	\$ -
TOTAL EXPENDITURES	\$ 68,921,365.00	\$ 70,061,863.00	\$ 71,621,837.00
OPERATING SURPLUS (DEFICIT)	\$ 17,399,133.00	\$ 18,772,591.00	\$ 19,025,346.00
TRANSFERS IN & OTHER SOURCES (8910-8979)	\$ 2,500,000.00	\$ 2,500,000.00	\$ 2,500,000.00
TRANSFERS OUT & OTHER USES (7610-7699)	\$ 753,971.00	\$ 753,971.00	\$ 753,971.00
CONTRIBUTIONS (8980-8999)	\$ (20,671,464.00)	\$ (21,756,998.00)	\$ (22,238,173.00)
CURRENT YEAR INCREASE (DECREASE) IN FUND BALANCE	\$ (1,526,302.00)	\$ (1,238,378.00)	\$ (1,466,798.00)
BEGINNING BALANCE	\$ 20,493,320.00	\$ 18,967,018.00	\$ 17,728,640.00
CURRENT-YEAR ENDING BALANCE	\$ 18,967,018.00	\$ 17,728,640.00	\$ 16,261,842.00
COMPONENTS OF ENDING BALANCE:			
Nonspendable Amounts (9711-9739)	\$ 59,584.00	\$ 59,584.00	\$ 59,584.00
Restricted Amounts (9740)	\$ -	\$ -	\$ -
Reserves for Economic Uncertainties (9789)	\$ 3,127,485.00	\$ 3,071,805.00	\$ 3,133,005.00
Committed Amounts (9750-9760)	\$ 7,577,183.00	\$ 7,163,109.00	\$ 5,696,312.00
Assigned Amounts (9780)	\$ -	\$ -	\$ -
Unassigned Amount Unrestricted (9790)	\$ 8,202,766.00	\$ 7,434,142.00	\$ 7,372,941.00
Unassigned Amount - Restricted (9790)			

I. IMPACT OF PROPOSED AGREEMENT ON SUBSEQUENT YEARS

Santa Cruz City Schools

MYP - Restricted General Fund

Santa Cruz Council of Classified Employees

	2022-23	2023-24	2024-25
	Total Current Budget After Settlement	First Subsequent Year After Settlement	Second Subsequent Year After Settlement
REVENUES			
Local Control Funding Formula (8010-8099)	\$ -	\$ -	\$ -
Remaining Revenues (8100-8799)	\$ 14,035,028.00	\$ 9,835,724.00	\$ 9,835,724.00
TOTAL REVENUES	\$ 14,035,028.00	\$ 9,835,724.00	\$ 9,835,724.00
EXPENDITURES			
Certificated Salaries (1000-1999)	\$ 8,948,977.00	\$ 7,877,445.00	\$ 7,995,563.00
Classified Salaries (2000-2999)	\$ 5,329,169.00	\$ 4,209,365.00	\$ 4,293,409.00
Employee Benefits (3000-3999)	\$ 11,027,166.00	\$ 10,322,486.00	\$ 10,571,903.00
Books and Supplies (4000-4999)	\$ 1,773,341.00	\$ 1,645,126.00	\$ 1,645,126.00
Services, Other Operating Expenses (5000-5999)	\$ 6,171,581.00	\$ 6,171,581.00	\$ 6,171,581.00
Capital Outlay (6000-6999)	\$ 236,131.00	\$ 236,131.00	\$ 236,131.00
Other Outgo (7100-7299) (7400-7499)	\$ -	\$ -	\$ -
Direct Support/Indirect Cost (7300-7399)	\$ 1,087,801.00	\$ 1,115,540.00	\$ 1,143,986.00
Other Adjustments		\$ -	\$ -
TOTAL EXPENDITURES	\$ 34,574,166.00	\$ 31,577,674.00	\$ 32,057,699.00
OPERATING SURPLUS (DEFICIT)	\$ (20,539,138.00)	\$ (21,741,950.00)	\$ (22,221,975.00)
TRANSFERS IN & OTHER SOURCES (8910-8979)	\$ -	\$ -	\$ -
TRANSFERS OUT & OTHER USES (7610-7699)	\$ -	\$ -	\$ -
CONTRIBUTIONS (8980-8999)	\$ 20,671,464.00	\$ 21,756,998.00	\$ 22,238,173.00
CURRENT YEAR INCREASE (DECREASE) IN FUND BALANCE	\$ 132,326.00	\$ 15,048.00	\$ 16,198.00
BEGINNING BALANCE	\$ 792,445.00	\$ 924,771.00	\$ 939,819.00
CURRENT-YEAR ENDING BALANCE	\$ 924,771.00	\$ 939,819.00	\$ 956,017.00
COMPONENTS OF ENDING BALANCE:			
Nonspendable Amounts (9711-9739)	\$ -	\$ -	\$ -
Restricted Amounts (9740)	\$ 924,771.00	\$ 939,819.00	\$ 956,017.00
Reserves for Economic Uncertainties (9789)			
Committed Amounts (9750-9760)	\$ -	\$ -	\$ -
Assigned Amounts (9775-9780)	\$ -	\$ -	\$ -
Unassigned Amount Unrestricted (9790)			
Unassigned Amount - Restricted (9790)			

I. IMPACT OF PROPOSED AGREEMENT ON SUBSEQUENT YEARS

Santa Cruz City Schools

MYP - Combined General Fund

Santa Cruz Council of Classified Employees

	2022-23	2023-24	2024-25
	Total Current Budget After Settlement	First Subsequent Year After Settlement	Second Subsequent Year After Settlement
REVENUES			
Local Control Funding Formula (8010-8099)	\$ 78,144,114.00	\$ 80,928,801.00	\$ 82,774,098.00
Remaining Revenues (8100-8799)	\$ 22,211,412.00	\$ 17,741,377.00	\$ 17,708,809.00
TOTAL REVENUES	\$ 100,355,526.00	\$ 98,670,178.00	\$ 100,482,907.00
EXPENDITURES			
Certificated Salaries (1000-1999)	\$ 39,182,658.00	\$ 38,551,580.00	\$ 39,122,517.00
Classified Salaries (2000-2999)	\$ 16,546,456.00	\$ 15,421,959.00	\$ 15,717,016.00
Employee Benefits (3000-3999)	\$ 29,345,767.00	\$ 29,428,092.00	\$ 30,450,415.00
Books and Supplies (4000-4999)	\$ 4,549,675.00	\$ 4,421,460.00	\$ 4,421,461.00
Services, Other Operating Expenses (5000-5999)	\$ 13,440,536.00	\$ 13,386,007.00	\$ 13,537,688.00
Capital Outlay (6000-6999)	\$ 405,077.00	\$ 405,077.00	\$ 405,077.00
Other Outgo (7100-7299) (7400-7499)	\$ 25,362.00	\$ 25,362.00	\$ 25,362.00
Direct Support/Indirect Cost (7300-7399)	\$ -	\$ -	\$ -
Other Adjustments		\$ -	\$ -
TOTAL EXPENDITURES	\$ 103,495,531.00	\$ 101,639,537.00	\$ 103,679,536.00
OPERATING SURPLUS (DEFICIT)	\$ (3,140,005.00)	\$ (2,969,359.00)	\$ (3,196,629.00)
TRANSFERS IN & OTHER SOURCES (8910-8979)	\$ 2,500,000.00	\$ 2,500,000.00	\$ 2,500,000.00
TRANSFERS OUT & OTHER USES (7610-7699)	\$ 753,971.00	\$ 753,971.00	\$ 753,971.00
CURRENT YEAR INCREASE (DECREASE) IN FUND BALANCE	\$ (1,393,976.00)	\$ (1,223,330.00)	\$ (1,450,600.00)
BEGINNING BALANCE	\$ 21,285,765.00	\$ 19,891,789.00	\$ 18,668,459.00
CURRENT-YEAR ENDING BALANCE	\$ 19,891,789.00	\$ 18,668,459.00	\$ 17,217,859.00
COMPONENTS OF ENDING BALANCE:			
Nonspendable Amounts (9711-9739)	\$ 59,584.00	\$ 59,584	\$ 59,584
Restricted Amounts (9740)	\$ 924,771.00	\$ 939,819	\$ 956,017
Reserves for Economic Uncertainties (9789)	\$ 3,127,485.00	\$ 3,071,805	\$ 3,133,005
Committed Amounts (9750-9760)	\$ 7,577,183.00	\$ 7,163,109	\$ 5,696,312
Assigned Amounts (9775-9780)	\$ -	\$ -	\$ -
Unassigned Amount Unrestricted (9790)	\$ 8,202,766.00	\$ 7,434,142	\$ 7,372,941
Unassigned Amount - Restricted (9790)			

J. IMPACT OF PROPOSED AGREEMENT ON UNRESTRICTED RESERVES

1. State Reserve Standard

		2022-23	2023-24	2024-25
a.	Total Expenditures, Transfers Out, and Uses (Including Cost of Proposed Agreement)	\$ 104,249,502.00	\$ 102,393,508.00	\$ 104,433,507.00
b.	State Standard Minimum Reserve Percentage for this District:	3%	3%	3%
c.	State Standard Minimum Reserve Amount for this District (For districts with less than 1,001 ADA, this is the greater of Line a, times Line b. OR \$71,000.)	\$ 3,127,485	\$ 3,071,805	\$ 3,133,005

2. Budgeted **Unrestricted** Reserve (After Impact of Proposed Agreement)

a.	General Fund Budgeted Unrestricted Reserve for Economic Uncertainties (9789)	\$ 3,127,485.00	\$ 3,071,805.00	\$ 3,133,005.00
b.	General Fund Budgeted Unrestricted Unassigned Amount (9790)	\$ 8,202,766.00	\$ 7,434,142.00	\$ 7,372,941.00
c.	Special Reserve Fund (Fund 17) Budgeted Reserves for Economic Uncertainties (9789)	\$ -	\$ -	\$ -
d.	Special Reserve Fund (Fund 17) Budgeted Unassigned Amount (9790)	\$ -	\$ -	\$ -
g.	Total Available Reserves	\$ 11,330,251.00	\$ 10,505,947.00	\$ 10,505,946.00
h.	Reserve for Economic Uncertainties Percentage	10.87%	10.26%	10.06%

3. Do unrestricted reserves meet the state minimum reserve amount?

2022-23	Yes	<input checked="" type="checkbox"/>	No	<input type="checkbox"/>
2023-24	Yes	<input checked="" type="checkbox"/>	No	<input type="checkbox"/>
2024-25	Yes	<input checked="" type="checkbox"/>	No	<input type="checkbox"/>

4. If not, how do you plan to restore your reserves?

5. If the total amount of the adjustment in Column 2 on Page 4c does not agree with the amount of the Total Compensation Increase in Section A, Line 5, Page 1 (i.e., increase was partially budgeted), explain the variance below:

The difference of \$433,943 is the amount of the contribution to the Restricted(429,758) General Fund and the rest is in Fund 13 and Fund 21 for 2022-23.

6. Please include any additional comments and explanations of Page 4 as necessary or any other information that you want to provide to assist us in our analysis.

L. CERTIFICATION NO. 1: CERTIFICATION OF THE DISTRICT'S ABILITY TO MEET THE COSTS OF COLLECTIVE BARGAINING AGREEMENT

The disclosure document must be signed by the district Superintendent and Chief Business Officer at the time of public disclosure.

In accordance with the requirements of Government Code Section 3547.5, the Superintendent and Chief Business Officer of Santa Cruz City Schools (District), hereby certify that the District can meet the costs incurred under the Collective Bargaining Agreement between the District and the Santa Cruz Council of Classified Employees Bargaining Unit, during the term of the agreement from July 1, 2022 to June 30, 2025.

The budget revisions necessary to meet the costs of the agreement in each year of its term are as follows:

<u>Budget Adjustment Categories:</u>	Budget Adjustment Increase (Decrease)
<u>Unrestricted Revenues/Other Financing Sources</u>	\$ (429,758.00)
<u>Unrestricted Expenditures/Other Financing Uses</u>	\$ 798,121.00
<u>Unrestricted Ending Balance Increase (Decrease)</u>	<u>\$ (1,319,965.00)</u>
<u>Restricted Revenues/Other Financing Sources</u>	\$ 429,758.00
<u>Restricted Expenditures/Other Financing Uses</u>	\$ 429,758.00
<u>Restricted Ending Balance Increase (Decrease)</u>	<u>\$ -</u>

N/A ____ (No budget revisions necessary)

District Superintendent
 (Signature)

Date

Chief Business Officer
 (Signature)

Date

M. CERTIFICATION NO. 2

The disclosure document must be signed by the district Superintendent or designee at the time of public disclosure and by the President or Clerk of the Governing Board at the time of formal board action on the proposed agreement.

The information provided in this document summarizes the financial implications of the proposed agreement and is submitted to the Governing Board for public disclosure of the major provisions of the agreement (as provided in the "Public Disclosure of Proposed Bargaining Agreement") in accordance with the requirements of AB 1200 and Government Code Section 3547.5.

District Superintendent (or Designee)
(Signature)

Date

Jim Monreal, Assistant Superintendent of Business Services
Contact Person

(831) 429-3410 x48224
Phone

After public disclosure of the major provisions contained in this summary, the Governing Board at its meeting on August 17, 2022, took action to approve the proposed Agreement with the Santa Cruz Council of Classified Employees Bargaining Unit.

President (or Clerk), Governing Board
(Signature)

Date

Special Note: The Santa Cruz County Office of Education may request additional information, as necessary, to review the district's compliance with requirements.

SANTA CRUZ CITY SCHOOLS DISTRICT

AGENDA ITEM: Staff Report: New Employee Report

MEETING DATE: August 17, 2022

FROM: Molly Parks, Assistant Superintendent, Human Resources

THROUGH: Kris Munro, Superintendent

BACKGROUND:

Santa Cruz City Schools (SCCS) welcomed forty-nine new certificated staff and four new administrators to the district.

The new certificated employee orientation highlighted a variety of topics that included: SCCS Vision and Goals, A Restorative Restart of School, Multi-Tiered Systems of Support Strategic Focus, SCCS Collective Commitments, Benefits, Partnership Administrators and Labor, and an introduction to the GSCFT and Leadership. The day ended with a bus tour of SCCS school sites. The second day of orientation included site orientations along with specific training on curriculum for elementary teachers.

FISCAL IMPACT:

\$47,543.30 LCFF Base (Unrestricted) Two Professional Development days for new staff

This work is done in support of the following district goals and their corresponding metrics:

Goal #4: We will develop a highly collaborative, professional culture focused on supporting effective teaching.

New Employee Report 2022-23

August 17, 2022

631/713





Certificated Hiring

- 4 Administrative Positions
- 81 Certificated Positions
 - 49 New Hires
 - 12 Rehires
 - 18 Transfers
 - 1 Long Term Sub
- 38 Summer School Positions



Who are the New Hires?

- **Elementary**

- **1 Principal**
- **10 Elementary**
- **2 Resource Specialists**
- **1 Two Way Immersion**

- **Middle School**

- **2 English**
- **1 Math**
- **2 Resource Specialists**
- **1 Science**



Who are the New Hires?

- **High School**

- **1 Assistant Principal**
- **2 Art**
- **1 Athletic Director**
- **1 Biology**
- **1 CTE Bike Tech**
- **2 Health/PE**
- **1 IB Coordinator**
- **3 Math**

- **1 Resource Specialist**
- **3 School Counselor**
- **1 Special Day Class**
- **2 Social Studies**
- **2 Spanish**
- **3 Special Day Class**



Who are the New Hires?

- **Alternative Education**

- **1 Elementary**
- **1 CTE Agriculture**
- **1 Social Studies**

- **Central Services**

- **1 School Nurse**
- **2 Speech Therapist**
- **1 IT Director**
- **1 Special Education
Program Specialist**



Positions Remaining to Fill

- **.8 or 1.0 English MHMS**
 - Consistent substitute from the first day of school - still looking for a teacher
- **.4 Music Teacher at Gault**
 - Admin covering for contractual obligation for 4th & 5th grade teachers
 - Attempting hire with Mountain Elementary - pair with a part-time position there

Recruiting Efforts

- Conducted interviews in person or via zoom
- Held SCCS Job Fair in March
- Joined the American Association of Employment in Education
- Continued in person fingerprinting
- Attended job fairs outside of SCCS
- Expanded social media to advertise job fair and job openings
- Worked closely with our university partners when openings were announced
- Used contacts within industry to recruit for Career Technical Education and Music
- Hired our first employees in February

637/713





New Teacher Orientation



639/713





**It's going to be a
great year!**

SANTA CRUZ CITY SCHOOLS DISTRICT

AGENDA ITEM: Tentative Agreement between the Greater Santa Cruz Federation of Teachers K-12 and Santa Cruz City Schools

MEETING DATE: August 17, 2022

FROM: Molly Parks, Assistant Superintendent, Human Resources

THROUGH: Kris Munro, Superintendent

RECOMMENDATION:

Approve the Tentative Agreement between the Greater Santa Cruz Federation of Teachers and Santa Cruz City Schools for 2022-23.

BACKGROUND:

A Tentative Agreement was reached on June 16, 2022 between Santa Cruz City Schools and the Greater Santa Cruz Federation of Teachers. The proposed agreement for 2022-23 will provide a 5% increase on the certificated salary schedule, starting July 1, 2022. It also includes a one-time off salary schedule payment of \$1,000 for FTE .51 to 1.00 (+) FTE and \$500 for FTE of .50 or below for 2022-23.

FISCAL IMPACT:

- A recurring annual cost \$2,109,880
- A one-time cost of \$460,950

Funding Sources: LCFF Base (Unrestricted), LCFF Supplemental (Restricted), Federal Categorical Programs (Restricted), State and Local Funds (Restricted and Unrestricted).

This work is in direct support of the following District goals and their corresponding metrics:

Goal #4: We will develop a highly collaborative, professional culture focused on supporting effective teaching.

Goal #5: SCCS will maintain a balanced budget and efficient and effective management.

Goal #6: SCCS will maintain strong communication and partnership with its diverse community.

AGENDA ITEM: 8.5.3.2.

Cay E C
6/16/22

Molly Packer
6/16/22

Tentative Agreement Jun 16, 2022

Article VII Hours of Employment

D. **Ending June 30, 2023**, Employees shall be at their work location one-half (1/2) hour prior to their first scheduled class, assignment, or preparation period, and shall remain for at least one-half (1/2) hour after their last class, assignment, or preparation period. This requirement shall be waived for all personnel assigned to more than one site. Part-time employees shall be required to work only their contractual percentage of the above.

Beginning in the 2023-2024 school year, all full time employees' work day will equate to 7.5 hour, or to the equivalent weekly average, as modified through any site specific negotiated side agreements. Any variation to the 7.5 day will be approved by site administrators. This does not preclude the other duties as outlined in this section of the contract or California Education Code.

Hours of Employment for Activity and Athletic Directors: *The requirement listed above shall be waived for Activity Directors and Athletic Directors to give flexibility to their work day in consideration of the after hours duties. Additionally, they will have flexible use of their preparation period in consideration of after hour duties. They will notify the office if they are leaving campus during the work day including prep periods. Activity Directors and Athletic Directors will use an electronic calendar and share it with all administrators.* Part-time employees shall be required to work only their contractual percentage of the above.

F. The administration shall schedule one faculty meeting per month (in addition to the first faculty meeting on the teacher workday). Second monthly faculty meetings will be calendared at the beginning of the year. The schedule of faculty meetings will be presented to staff prior to the start of the instructional year and adjusted if date time conflicts are noted for educational and/or school-wide needs. Agenda items for a proposed

second monthly faculty meeting will be provided to the democratically selected site leadership team for collaborative input and review. Final discretion for the determination of need to hold a faculty meeting resides with the Principal (site administrator). Second monthly faculty meetings shall only be held when timely business items were not able to be discussed at the first faculty meeting of that month. All faculty meetings will be held on a scheduled workday, will not exceed seventy five (75) minutes, unless agreed upon by the staff to continue, and will initiate within thirty (30) minutes after the last class. The first staff meeting of the year (before school starts) can be up to two (2) **There may be an additional 75 min faculty meeting scheduled in August without the process used for second faculty meetings.**

The calendar shall be mutually agreed upon by the District and the Federation. Should the Federation and the District be unable to agree on a calendar for the subsequent school year by **April" February 1st** of the current year, the District retains the right to establish the opening day **and closing day** of school .

~~New math and science certificated staff to the District will be placed on the current certificated salary schedule. Per the February 2010 Side Letter Agreement Retirement Incentive:~~ New incoming math, science **and Foreign Language** certificated staff will receive a maximum of **eleven (11) Fifteen 15** years of service credit. ~~effective July 1, 2017 until otherwise negotiated, except by mutual agreement. There will be a "retro catch up" on the salary schedule for credentialed math and science certificated staff prior to July 1, 2017. Effective July 2013,~~ faculty with valid mild to moderate Special Education Credentials, valid moderate to severe Special Education Credentials, valid Speech-Language Pathology Services Credentials, **Psychologist, Adaptive PE Teachers, Deaf Hard of Hearing** and valid School Nurse Services Credentials shall receive a maximum placement on the salary schedule at step ~~42~~ **20** reflecting years of prior experience. **The district will conduct a study going back to July 1, 2017 of current employees' service credit status to determine the cost for granting**

employees seven or eight years of service credit, instead of five as in current contract. In the first semester of 2023, the district will share results of the study with GSCFT.

Article XII - Involuntary Transfer

B. Reasons

An involuntary transfer shall be initiated by the District. An involuntary transfer may occur to fill a vacancy or may occur regardless of the existence of a vacancy, and shall be based upon the legitimate educationally related needs of the District, such as:

1. Staff, student and/or program needs as determined by the Superintendent. ~~Upon request by the unit member involved, the Superintendent shall put his/her reasons in writing.~~

C. Procedure

3. A recommendation to involuntarily transfer a unit member shall take place only after a meeting or consultation between the unit member and his/her administrator. ~~Within three (3) days, the site administrator shall provide the unit member with a written summary of the conference. The summary shall be on file in the Human Resources Office, but not in the employee's personnel file.~~ If, after two (2) days and a concerted effort to meet or consult with the unit member, the site administrator finds that the teacher is unavailable, a written communication ~~emailed to~~ ~~placed in~~ the unit member's mailbox and ~~sent to the last home address via registered mail~~ shall be used. The unit member shall have three (3) ~~weeks days~~ to respond from the date of ~~the sent email mailing until August 1st; after that, one (1) week.~~ If the unit member fails to respond to the ~~registered letter email or designee~~, the involuntary transfer recommended shall take place. ~~During summer we will email the unit member's personal email and make a phone call. If there is no response in five (5) days, the involuntary transfer recommended shall take place.~~

4. Upon request, the Superintendent shall meet with the unit member being considered for involuntary transfer.
5. Recommended transfers shall be acted upon by the Superintendent as soon as possible, based on availability of all parties involved in the decision, or their designees. ~~Upon written request from the transferee, the Superintendent shall give in writing the reason(s) for the transferee's involuntary transfer. The written request and the written response shall be on file in the Human Resources Department, but not in the employee's personnel file.~~⁵
6. Involuntary transfer of the same teacher shall not be made more than twice within a ~~four (4)~~ ^{two (2)} year period.
7. The District shall transport all materials being moved from one school site to another, provided that the transferee prepares such materials for movement.
8. ~~In the event of an involuntary transfer, at the discretion of the involuntarily transferred employee, the employee will inform the Assistant Superintendent of Human resources of his/her choice to either accept a \$300.00 packing/unpacking stipend or two (2) days release time. Said release time is to be expended on mutually agreed upon dates between the transferee and the site administrator involved.~~
9. In the event of involuntary transfer, the unit budget for the transferee's school shall receive an allocation of ~~\$300~~ ^{\$600} per transferee from the District budget, to be used to purchase instructional materials for the classroom.

D. Appeal

1. Procedural aspects of these Articles shall be grievable.
2. The reasons for involuntary transfer shall not be grievable, but may be appealed to the Board of Education. The decision of the Board shall be final. The teacher(s) involved shall have the right to representation of their choice.
3. ~~An employee who has been involuntarily reassigned or transferred into a teaching assignment may voluntarily request the assistance of Subject Area Specialists as outlined in the Peer Assistance and~~

~~Review Program Side letter for the first year of his/her new assignment. Such participation in the program shall not be a part of the teacher evaluation and shall not be placed in the teacher's personnel file.~~

Letter L pertaining to days related to moves: Beginning in the 2006-07 school year, the work year shall be one hundred eighty five days (185) workdays. First year employees shall work one hundred eighty five days (185) workdays with two (2) additional days added at the beginning of the school year for in-service and other appropriate activities, to be compensated at their per diem rate. *Teachers will be assigned a classroom for the following school year by the last week of instruction, and prior to the last teacher workday. If the room assignment is changed by school administrators after the last day of instruction, the teachers being moved will be given a \$300 stipend to move and set up their classroom.*

Article XIII: Class Size, Letter F: Combination Classes

1. *Elementary general education* combination classes should be formed only when absolutely necessary or by staff request.
2. Teacher input should weigh heavily in determining which students are placed in combination classes.
3. Administrators will attempt to make the grade level ratios as close to ~~The grade ratio for combination classes should be close to~~ 50:50 as possible. ~~A ratio should be no more than 40:60 with 60% of the students in the higher grade level.~~
4. ~~The limit of twenty-five (25) should be considered as the desirable class size but not the mandated maximum.~~
5. When possible, new teachers should not be assigned to combination classes.
6. Administration and grade level teachers should negotiate the assignment of combination classes. Factors to consider include teacher interest, experience, personal concerns, and teachers on waivers or temporary status.

7. Grade level teacher(s) may agree, with administrator approval, to increase class size(s) by one student per class in order to avoid the creation of a combination class.if permitted by ed code and the contract
8. Teachers assigned to combination classes will be allocated \$600, not including programs or school of choice (Monarch and TWI)

Article XVII: Salary and Benefits,

10. The hourly rate of pay assignments not covered by a salary schedule or individual contract shall be \$40.00 beginning August 10, 2022. The rate of pay for classroom teachers serving as guest teachers on their duty free preparation period, or during uncontracted time will be \$50 per hour. If a teacher is asked to act as a substitute by covering another teacher's class while they are simultaneously teaching their own class, the teacher will be compensated at the \$50 per hour rate.

B. Parent Conference Compensation: Classroom teachers in grades 4 and 5 will be paid up to an additional 4 hours at the negotiated hourly rate to accommodate parent teacher conferences above 23 students. This additional increase is intended to increase the number of families that the teacher will conference with.

11. A salary increase of 5% shall be applied to the salary schedule beginning July 1, 2022. In addition to the 5%, a one time off salary schedule payment of \$1,000 will be paid to employees .51 FTE and above. A one time off salary schedule payment of \$500 will be paid to employees .50 FTE and below. This one time off salary schedule will be paid to employees who are employed by the first day of school, August 10, 2022, and remain employed on the date of distribution of the payment.

CTE Stipend will be added to the stipend schedule along with stipend

requirements (see attached) of \$1882

Guest Teacher Contract:

New rates for subbing beginning August 10, 2022 will be:

\$150 per day up to 20 days

\$180 per day after 20 days

SANTA CRUZ CITY SCHOOLS DISTRICT

AGENDA ITEM: Tentative Agreement between Santa Cruz City Schools and the Santa Cruz Council of Classified Employees

MEETING DATE: August 17, 2022

FROM: Molly Parks, Assistant Superintendent, Human Resources

THROUGH: Kris Munro, Superintendent

RECOMMENDATION:

Approve the Tentative Agreement between the Greater Santa Cruz Federation of Teachers and Santa Cruz City Schools for 2022-23.

BACKGROUND:

A Tentative Agreement was reached on June 16, 2022 between Santa Cruz City Schools and the Santa Cruz Council of Classified Employees. The proposed agreement for 2022-23 will provide a 5% increase on the classified salary schedule, starting July 1, 2022. It also includes a one-time off salary schedule payment of \$1,250 for FTE .51 to 1.00 (+) FTE and \$625 for FTE of .50 or below for 2022-23.

FISCAL IMPACT:

- A recurring annual cost of \$908,299
- A one-time cost of \$415,851

Funding Source: LCFF Base (Unrestricted), LCFF Supplemental (Restricted), Federal Categorical Programs (Restricted), State and Local Funds (Restricted and Unrestricted).

This work is in direct support of the following District goals and their corresponding metrics:

Goal #4: We will develop a highly collaborative, professional culture focused on supporting effective teaching.

Goal #5: SCCS will maintain a balanced budget and efficient and effective management.

Goal #6: SCCS will maintain strong communication and partnership with its diverse community.

Chantel Brown
6/16/22

Tentative Agreement between
SCCS and SCCCE
June 16, 2022

Mully Parks
6/16/22

A salary increase of 5% shall be applied to the salary schedule beginning July 1, 2022. In addition to the 5%, a one time off salary schedule payment of \$1,250 will be paid to employees .51 FTE and above. A one time off salary schedule payment of \$625 will be paid to employees .50 FTE and below. This one time off salary schedule payment will be paid to employees in permanent status as of the first day of school, August 10, 2022, and must be in employed status on the date of distribution of payment.

Negotiations will continue with contract language for the 2022-23 school year in the Fall.

SANTA CRUZ CITY SCHOOL DISTRICT

AGENDA ITEM: Pandemic Lessons

MEETING DATE: August 17, 2022

FROM: Dorothy Coito, Assistant Superintendent of Educational Services

THROUGH: Kris Munro, Superintendent

BACKGROUND:

On March 16, 2020, when Santa Cruz City Schools moved to distance learning due to COVID-19, staff could not have imagined the tremendous impact the pandemic would have on all facets of our organization. Upon reflection, there is much that has been learned that will inform our work into the future.

Some of the ways that pandemic lessons continue to inform our work include:

- Partnering with County Public Health and the County Office of Education, staff have developed systems to mitigate viral spread.
- Expanded academic support programs and systems have been developed to meet students' needs.
- An expanded social emotional / mental health support system addresses increasing needs.
- New district systems and partnerships address food insecurity.
- Internet access and technology has been provided to all students who need it, allowing our district to close the digital divide.
- Expanded digital resources have increased academic interventions and support and support daily classroom instruction.
- New communication tools have been adopted to solicit stakeholder feedback.
- Nurturing partnerships with our community so the district can meet more needs and connect families with resources.
- The Human Resources Team has implemented new tools for recruitment.
- Leadership has doubled down on its efforts to support employee agency.
- All efforts are focused on supporting acceleration of learning through the power of collective teacher efficacy and high impact instructional strategies.

Perhaps the most important lesson of the pandemic has been that our learning organization can change swiftly to meet the needs of our students.

In 22-23 we remain committed to the goal of providing a rigorous, guaranteed and viable curriculum for all students supported by the work of our SCIL (Santa Cruz Instructional Leadership) and Curriculum & Assessment Teams. The reset of Professional Learning Communities (PLCs), the implementation of an updated English Learner Master Plan, and the

AGENDA ITEM: 8.5.4.1.

continued use of high impact instructional strategies have served to intensify our efforts in supporting student academic excellence and social emotional health.

This work is in direct support of the following District goals and their corresponding metrics:

Goal #1: All Santa Cruz City Schools students will be prepared to successfully access post-secondary college and career opportunities.

Goal #2: SCCS will create positive, engaging school environments that promote the development of cognitive skills and the social emotional well-being of all students.

Goal #3: We will eliminate the achievement gaps that currently exist between demographic groups within the SCCS student community.

Goal #4: We will develop a highly collaborative, professional culture focused on supporting effective teaching.

Goal #5: SCCS will maintain a balanced budget and efficient and effective management.

Goal #6: SCCS will maintain strong communication and partnership with its diverse community.



Santa Cruz City Schools: What we learned during **lockdown and through our restorative restart . . .**

August 17, 2022



Having clear values and goals served as a guide for our work.

We Believe

Public School is the foundation of democracy

Every person has intrinsic worth

High expectations foster greater achievement

All are responsible for the welfare of our community

Diversity is an asset in our community

Relationships are built on honesty & integrity

Schools must provide access & equity

People thrive in safe environments.

& We Will

Make all students college / career ready.

Create positive, engaging environments.

Eliminate achievement gaps.

Maintain a collaborative culture supporting effective teaching.

Commit all resources to efficiently support excellence & equity.

Communicate & partner with our diverse community.





**We learned
how adaptable we are**

We learned how adaptable we are.

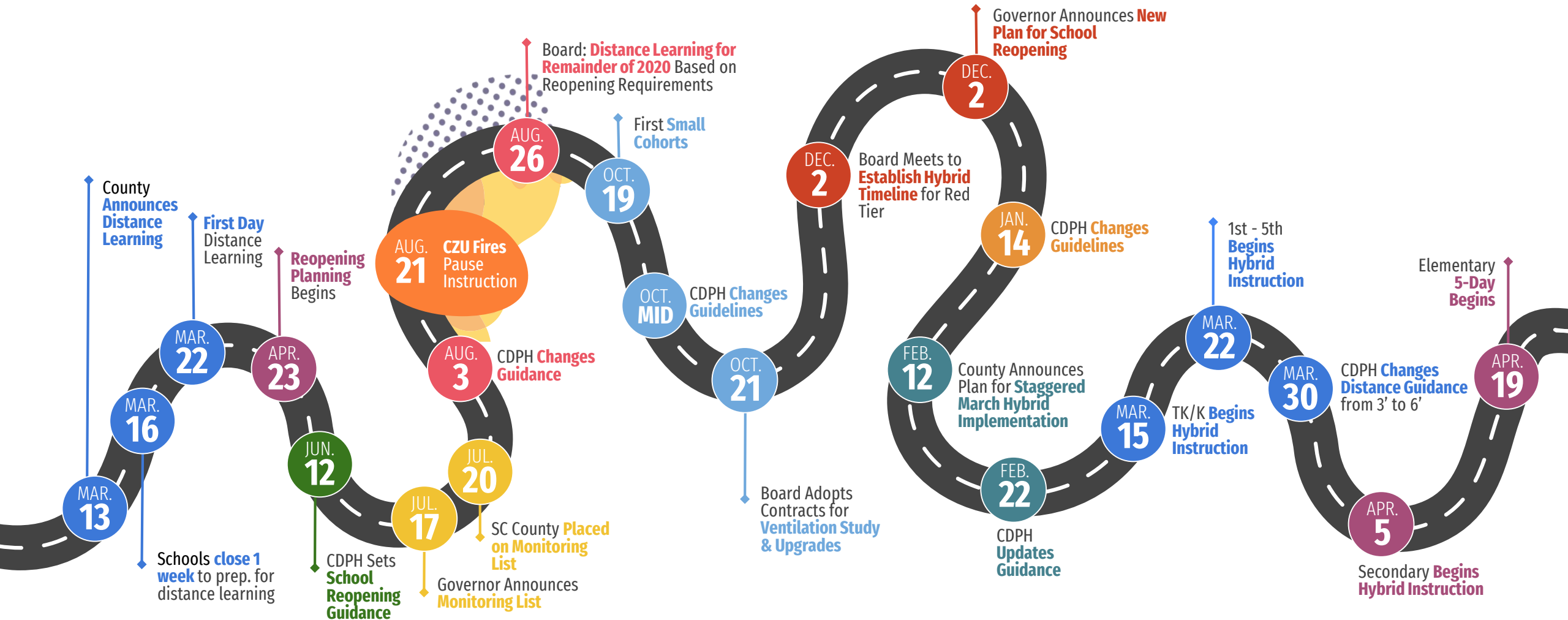

Building New Health Systems

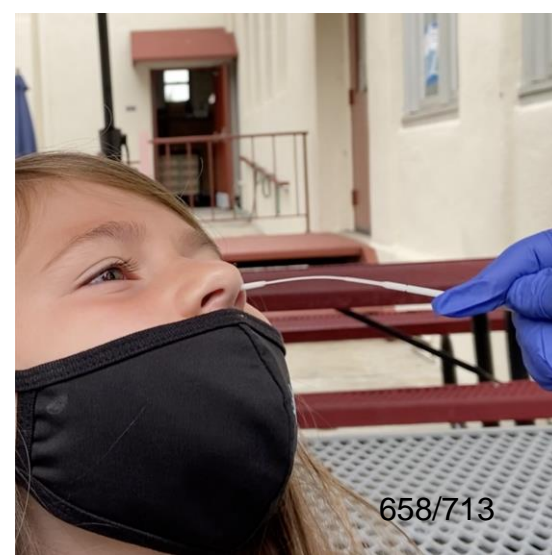

658/713

Ever changing COVID mitigation





TK-K Hybrid



1st – 5th Hybrid



Secondary Hybrid

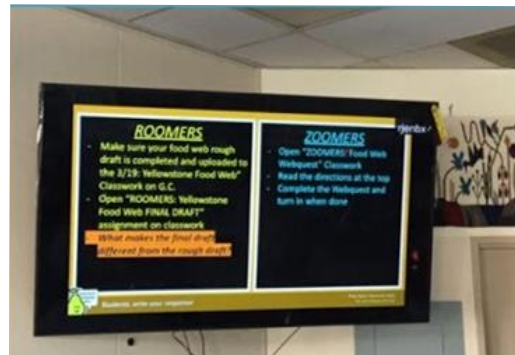



How this informs our work:

- COVID Compliance Manager
- Exposure notification systems
- Partnerships & systems for vaccines and testing
- Consistent messaging & communication



**We learned who
needs more help & we
learned how far
our reach can be.**

Small Cohorts

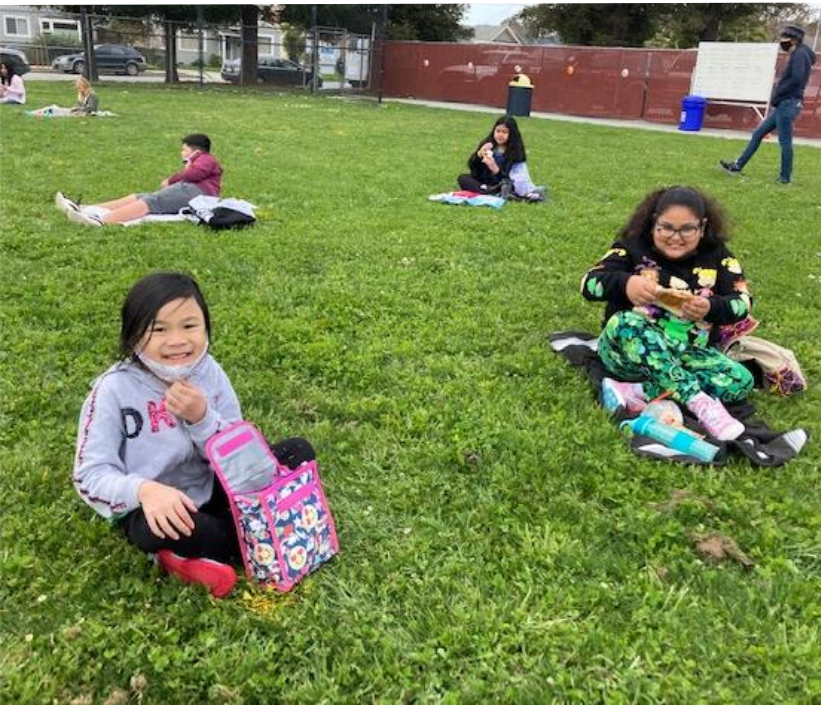



Small Cohorts





Summer School Programs



667/713



Addressing Food Insecurity



668/713



Addressing the Digital Divide



669/713

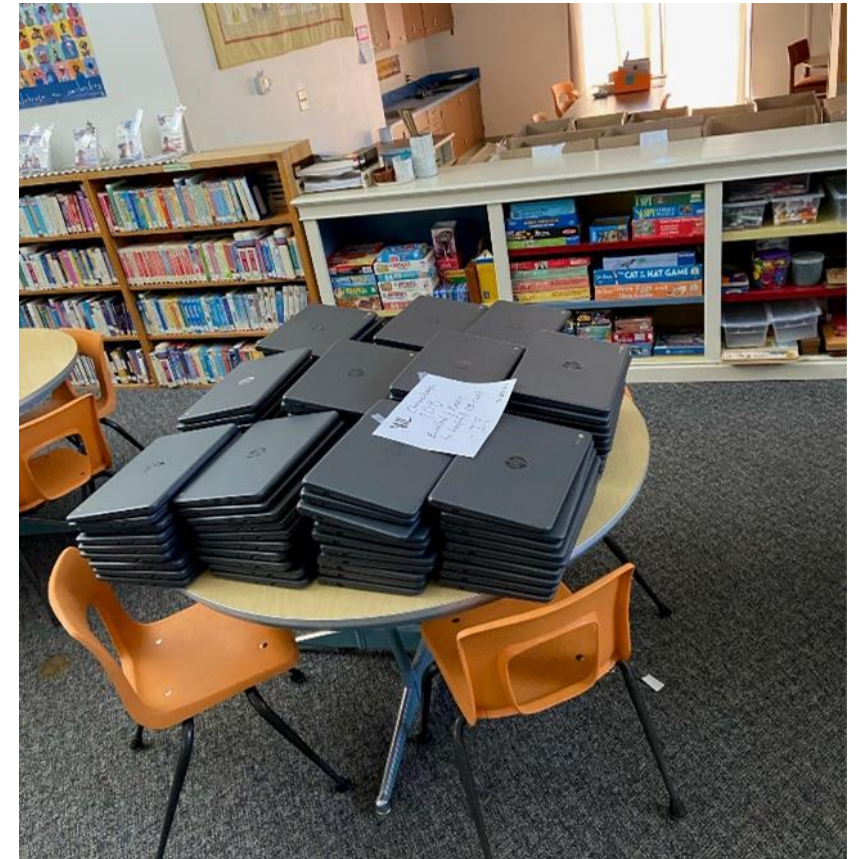

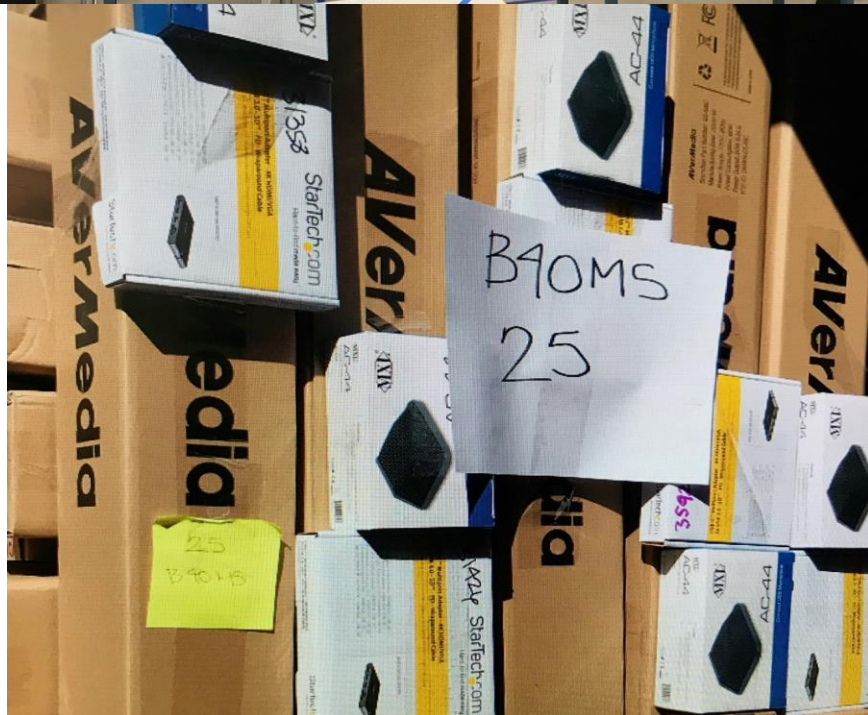
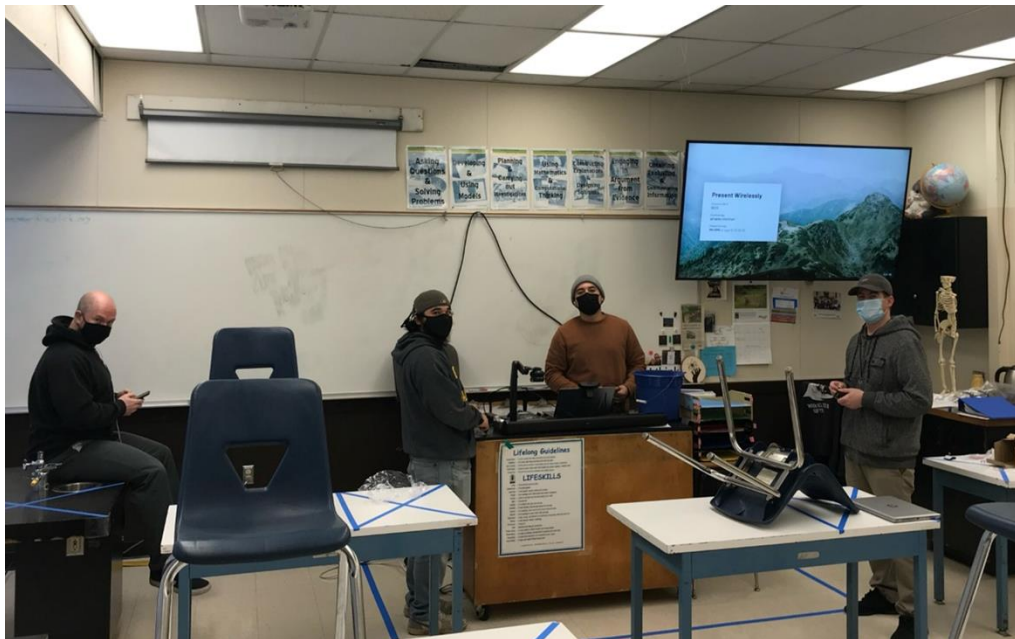

Deploying Technology



We distributed:

310,000+

Meals

4,100+

Chromebooks

1,100+

Hotspots

40,000+

Vaccinations



How this informs our work:

- New tools to solicit student and family feedback to identify needs
- Creating new systems for support referrals by self & by staff
- Expanded Academic Supports
 - Small Group Interventions
 - Expanded Response to Intervention Support
 - Online academic supports
 - Peer Tutoring
 - After School Programs at all sites



How this informs our work:

- Expanded Social Emotional Supports
 - Additional social workers
 - Social Emotional Health Counselors
 - Broadened community partnerships for ongoing social supports
- Continuing to address Food Insecurity
 - Free meals for all
 - Implementation of Food Pantries
- Technology use has changed in our district (5 year tech plan goals met in one year)
 - All households have access to internet
 - Every student has a dedicated chromebook
 - Instructional technology supports student learning & engagement
 - Tech tools support home to school communication



We learn to use new
communication tools to seek
community input

Adopted new tools to solicit ongoing feedback from our community





We learned **the power**
of **our community**
partnerships.



Public Health
Prevent. Promote. Protect.
Santa Cruz County





How this informs our work:

- Ongoing enriched collaboration with County Office of Education & Partner Districts on COVID response and student support
- Ongoing and expanded partnerships with County Health & other health providers to address COVID and other family health needs with our School Community Coordinators
- Senderos partners for family outreach and addresses family food and housing insecurity and provides academic & social emotional supports
- Encompass, National Alliance on Mental Illness (NAMI), Monarch Services provide in classroom and out of classroom resources for both students & families



**We learned more about
our staff needs.**

How this informs our work:

We learned new venues for employee recruitment.

We learned that the pandemic years have been exceptionally challenging and impactful for all of our employees:

- We recognize that we need to continue to purposely support employee well-being.
- We want to support effective employee induction
- We know it is critical that we acknowledge and celebrate hard work
- We recognize that we must support teacher and staff agency by:
 - creating venues for effective collaboration
 - soliciting feedback and needs
 - providing meaningful feedback for adult learning in a supportive environment
 - monitoring our impact & celebrating the small and big wins



We continued to recognize the importance of investing in **collective teacher efficacy & high impact instructional strategies**



“

Effective classrooms don't just happen. They are led by teachers who deeply understand their craft and the essential nature of the interaction between student, teacher, and content.”

Doug Fisher

Engagement by Design



How this informs our work:

- Rebooting Professional Learning Communities
- Establishing Curriculum & Assessment Teams
 - Priority Standards
 - Common Assessments
- Focusing on High Impact Instructional Strategies
- Implementing English Learner Master Plan



Curriculum & Assessment Teams

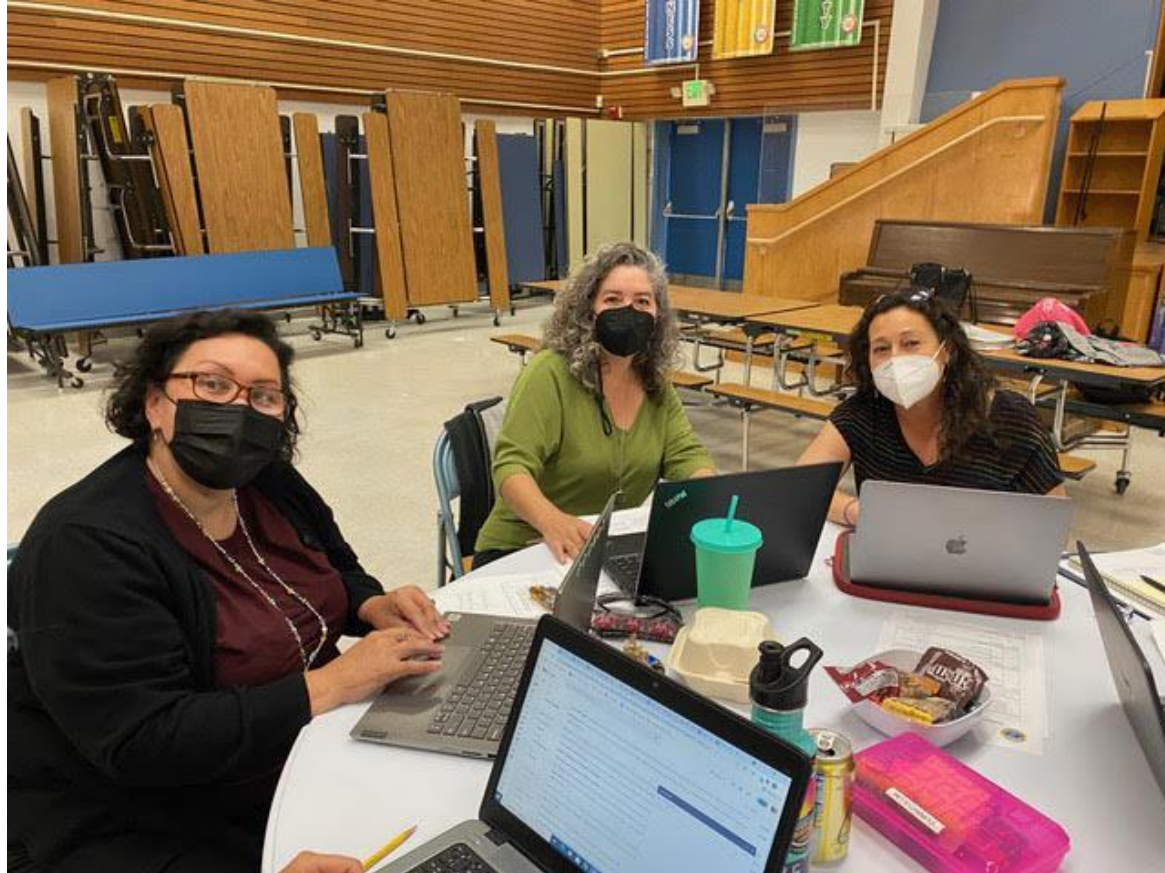

High Impact Instructional Strategies Toolkit

- **Designed to provide clarity** on districtwide Tier 1 instructional strategies
- **Designed to be a resource** to support purposeful Tier 1 instruction to accelerate learning and close the achievement gap
- Based in **Visible Learning** & Hattie's **high effect size strategies**
- A support for **professional learning**
- A **dynamic tool** that will evolve over time



2022-23 Focus - Building on Success:



Committing to these Essential Understandings & Beliefs

To build a culture of excellence & equity:

- We recognize that student learning is the focus.
- We recognize that sustained improvement requires collective effort.
- We stick to what **the data** tells us.
- We accept difficult facts and act on them.
- We need each other to truly address the needs of our students.
- We need to provide & support high quality instructional leadership at all levels
- We must build strong, caring relationships to ensure the well-being & academic success of every student

Demographics ≠ Outcomes

"In schools where there is a high degree of collective responsibility for academic success & failure, students thrive."

Fisher, Frey, Smith & Hattie ~

"Leading the Rebound: 20+ Must Dos to Restart Teaching & Learning"

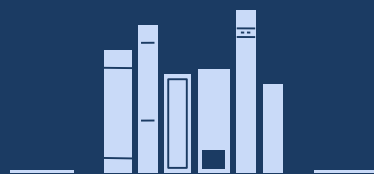

**We have the power to change
the learning trajectory of students**
when everyone in our learning
communities holds to the belief that **every
student can learn at high levels.**





Our most important lesson is that we can change swiftly to meet student needs.

Questions?



SANTA CRUZ CITY SCHOOL DISTRICT

AGENDA ITEM: Board Policies: First and/or Final Reading for CSBA Revisions & Updates

MEETING DATE: August 17, 2022

FROM: Kris Munro, Superintendent

RECOMMENDATION:

Approve the revised/deleted/new policies as submitted for second and/or final reading and adoption.

BACKGROUND:

Policies are submitted through the GAMUT online board policy book updating process, which uses CSBA recommendations for review and change approximately six times per year in participating districts. These recommendations reflect recent changes in education code and/or case law. The policies have been reviewed by staff to ensure that any required customization for Santa Cruz City Schools has been included. The Policy Guidesheet provides a basic overview of the policy changes.

This work is in direct support of the following district goals and its corresponding metrics:

Goal #1: All SCCS students will be prepared to successfully access post-secondary college and career opportunities.

Goal #2: SCCS will create positive, engaging school environments that promote the development of cognitive skills and the social emotional well-being of all students.

Goal #3: We will eliminate the achievement gap the currently exists between demographic groups within the SCCS student community.

Goal #4: We will develop a highly collaborative, professional culture focused on supporting effective teaching.

Goal #5: SCCS will maintain a balanced budget and efficient and effective management.

Goal #6: SCCS will maintain strong communication and partnerships with its diverse community.

AGENDA ITEM: 8.5.5.1.

CSBA POLICY GUIDE SHEET
June 2022

Board Policy 0420.41 - Charter School Oversight

Policy updated to reflect that a charter school proposing to expand operations to one or more additional sites or grade levels is required to request a material revision to its charter and notify the Governing Board of the additional locations or grade levels whether a proposal to expand operations is concurrent with or unrelated to a renewal, add a new section heading "Fees/Charges for Supervisorial Oversight" and rearrange material within this section for clarity, provide that it is the County Superintendent of Schools who may request that the California Collaborative for Educational Excellence be assigned to provide assistance to a charter school that fails to improve outcomes in regard to state or school priorities identified in the charter, as specified, and add that complaints alleging noncompliance with Education Code 47606.5 (annual update of school goals, actions, and related expenditures or 47607.3 (technical assistance or intervention based on the school's failure to improve student outcomes) may be filed anonymously if the complaint provides evidence or information leading to evidence to support an allegation of noncompliance.

Board Policy 3110 - Transfer of Funds

Policy updated to delete an authorization for the temporary transfer of funds which only pertained to the 2020-21 and 2021-22 fiscal years.

NEW - Board Policy 3523 - Electronic Signatures

New policy reflects the authorization for districts to use electronic signatures in their communications and operations, including the benefits of electronic records and signatures, the requirement that electronic signatures conform with criteria described in law and that the level of security is sufficient for the transaction being conducted, and that electronic records are retained in accordance with law and regulations and as specified in board policy and administrative regulation.

Board Policy 3550 - Food Service/Child Nutrition Program

Policy updated to reflect **NEW LAW (AB 130, 2021)** which requires districts to provide a nutritionally adequate breakfast and lunch to any student who requests a meal, regardless of the student's free and/or reduced-price meal eligibility, and **NEW LAW (AB 486, 2021)** which authorizes the coordination of food service programs with classroom instruction and other related district programs.

Board Policy 3551 - Food Service Operations/Cafeteria Fund

Policy updated to reflect **NEW LAW (AB 130, 2021)** which requires districts to provide a nutritionally adequate breakfast and lunch to any student who requests a meal, regardless of the student's free and/or reduced-price meal eligibility, including revisions to the "Meal Sales" and "Program Monitoring and Evaluation" sections.

Board Policy 3553 - Free and Reduced Price Meals

Policy updated to reflect **NEW LAW (AB 130, 2021)** which requires districts to provide a nutritionally adequate breakfast and lunch to any student who requests a meal, regardless of the student's free and/or reduced-price meal eligibility. Updated policy includes general requirements applicable to federal National School Lunch and Breakfast Programs as well as the state Universal Meal Program. Updated Policy also includes revision to the "Confidentiality/Release of Records" section to permit the use of student information to facilitate the provision of targeted educational services to a student based on the local control and accountability plan, as clarified in the California Department of Education's Management Bulletin SNP-02-2018.

Policy 0420.41: Charter School Oversight

Status: ADOPTED

Original Adopted Date: 10/01/2013 | Last Revised Date: 06/01/2022 | Last Reviewed Date: 06/01/2022

The Governing Board recognizes its ongoing responsibility to oversee that any charter school authorized by the Board is successfully fulfilling the terms of its charter and is providing a high-quality educational program for students enrolled in the charter school.

The Superintendent or designee shall identify at least one staff member to serve as a contact person for each charter school authorized by the Board. (Education Code 47604.32)

The Superintendent or designee shall visit each charter school at least annually and may inspect or observe any part of a charter school at any time. (Education Code 47604.32, 47607)

The Superintendent or designated charter school contact shall attend meetings of the charter school governing body whenever possible and shall periodically meet with a representative of the charter school.

Waivers

If the charter school wishes to request a general waiver of any state law or regulation applicable to it, it shall request that the district submit a general waiver request to the State Board of Education (SBE) on its behalf. Upon approval of the Board, the Superintendent or designee shall submit such a waiver request to SBE on behalf of the charter school.

Provision of District Services

The charter school may purchase administrative or other services from the district or any other source. (Education Code 47613)

Whenever the district agrees to provide administrative or support services to a charter school, the district and the charter school shall develop a memorandum of understanding (MOU) which clarifies the financial and operational agreements between them.

At the request of a charter school, the Superintendent or designee shall create and submit any reports required by the State Teachers' Retirement System or Public Employees' Retirement System on behalf of the charter school. The district may charge the charter school for the actual costs of the reporting services, but shall not require the charter school to purchase payroll processing services from the district as a condition for creating and submitting these reports. (Education Code 47611.3)

Material Revisions to Charter

Material revisions to a charter may only be made with Board approval. Material revisions shall be governed by the same standards and criteria that apply to petitions for the authorization of charter schools as set forth in Education Code 47605 and shall include, but not be limited to, a reasonably comprehensive description of any new requirement for charter schools enacted into law after the charter was originally granted or last renewed. (Education Code 47607)

If an approved charter school proposes to **expand** operations to one or more additional sites or grade levels, **whether concurrently with or unrelated to a renewal**, the charter school shall request a material revision to its charter and shall notify the Board of those additional locations or grade levels. The Board shall consider approval of the additional locations or grade levels at an open meeting. (Education Code 47605, **47607**)

The Board shall have the authority to determine whether a proposed change in charter school operations constitutes a material revision of the approved charter.

Monitoring Charter School Performance

Any charter school authorized by the **Board shall be monitored by the Superintendent or designee** to determine whether **the charter school** complies with all legal requirements applicable to charter schools, including all reports required of charter schools **by law, as specified** in Education Code 47604.32. Any violations of law shall be reported to the Board.

The Board shall monitor each charter school to determine whether it is achieving the measurable student outcomes set forth in the charter, both schoolwide and for each numerically significant student subgroup served by the school as defined in Education Code 52052. This determination shall be based on the measures specified in the approved charter and any applicable **MOU**, and on the charter school's annual review and assessment of its progress toward the goals and actions identified in its local control and accountability plan (LCAP), as reported in the California School Dashboard.

The Board shall monitor the fiscal condition of the charter school based on any financial report or information obtained from the charter school, including, but not limited to, the charter school's preliminary budget, **LCAP and** annual update of the charter school's LCAP, first and second interim financial reports, and final unaudited report for the full prior year. (Education Code 47604.32, 47604.33, 47606.5)

Fees/Charges for Supervisorial Oversight

The district may charge **for district supervisorial oversight as follows: (Education Code 47613; 5 CCR 11969.7)**

1. **Actual costs** up to one percent of **the** charter school's revenue if the **district provides the** charter school **with** facilities **under Education Code 47614 and charges** the **charter school a pro-rata share of** the **facilities cost**
2. **Actual costs** up to three percent of the charter school's revenue **if the district provides the charter school substantially rent-free facilities**

Technical Assistance/Intervention

Whenever a charter school is identified for technical assistance based on the performance of one or more numerically significant student subgroups on SBE-established criteria, the charter school shall receive technical assistance from the County Superintendent of Schools. Such technical assistance shall be focused on building the charter school's capacity to develop and implement actions and services responsive to student and community needs, including, but not limited to, any of the following: (Education Code 47607.3)

1. Assisting the charter school to identify its strengths and weaknesses in regard to the state priorities applicable to the charter school pursuant to Education Code 47605. This shall include working collaboratively with the charter school to review performance data on the state and local indicators included in the California School Dashboard and other relevant local data and to identify effective, evidence-based programs or practices that address any areas of weakness.
2. Working collaboratively with the charter school to secure assistance from an academic, programmatic, or fiscal expert or team of experts to identify and implement effective programs and practices that are designed to improve performance in any areas of weakness identified by the charter school. Another service provider, including, but not limited to, a school district, county office of education, or charter school, may be solicited to act as a partner to the charter school in need of technical assistance.
3. Obtaining from the charter school timely documentation demonstrating that it has completed the activities described in **Items #1 and 2** or substantially similar activities, or has selected another service provider to work with the charter school to complete the activities described in **Items #1 and 2** or substantially similar activities, and ongoing communication with the Board to assess the charter school's progress in improving student outcomes.

In addition, if, in three out of four consecutive school years, a charter school fails to improve outcomes for three or

more numerically significant student subgroups, or for all of the student subgroups if the school has fewer than three subgroups, in regard to one or more state or school priorities identified in the charter, the **County Superintendent may** request that the Superintendent of Public Instruction (SPI), with SBE approval, assign the California Collaborative for Educational Excellence to provide advice and assistance to the charter school pursuant to Education Code 52074. (**Education Code 47607.3; 52072**)

In accordance with law, the Board may deny a charter school's renewal petition or may revoke a charter based on the charter school's poor performance, especially with regard to inadequate academic achievement of all numerically significant subgroups of students served by the charter school.

Complaints

Each charter school shall establish and maintain policies and procedures in accordance with the uniform complaint procedures as specified in 5 CCR 4600-4670 **to enable any person** alleging the school's noncompliance with Education Code 47606.5 or 47607.3 **to file a complaint with the charter school.** (Education Code 52075)

A complaint may be filed anonymously if the complaint provides evidence or information leading to evidence to support an allegation of noncompliance. A complainant who is not satisfied with the decision may appeal the decision to the SPI. (Education Code 52075)

If the charter school finds merit in the complaint or the SPI finds merit in an appeal, a remedy shall be provided to all affected students and parents/guardians. (Education Code 52075)

School Closure

In the event that the Board revokes or denies renewal of a charter or the charter school ceases operation for any reason, the Superintendent or designee shall, when applicable in accordance with the charter and/or **an MOU,** provide assistance to facilitate the transfer of the charter school's former students and to finalize financial reporting and close-out **of the charter school.**

The Superintendent or designee shall provide notification to the California Department of Education, within 10 calendar days of the Board's action, if renewal of **a** charter is denied, **a** charter is revoked, or a charter school will cease operation for any reason.

Such notification shall include, but not be limited to, a description of the circumstances of the closure, the effective date of the closure, and the location of student and personnel records. (Education Code 47604.32; 5 CCR 11962.1)

Policy Reference Disclaimer: These references are not intended to be part of the policy itself, nor do they indicate the basis or authority for the board to enact this policy. Instead, they are provided as additional resources for those interested in the subject matter of the policy.

State References

5 CCR 11700-11705

Description

Independent study

5 CCR 11960-11969.10

Charter schools

5 CCR 4600-4670

Uniform complaint procedures

Bus. Code 7583.45

Training for security officers

CA Constitution Article 16, Section 8.5

Public finance; school accountability report card -

<https://simbli.eboardsolutions.com/SU/5WQGqQCplusFH2CplOCVLEpzQ==>

CA Constitution Article 9, Section 5

Common school system -

<https://simbli.eboardsolutions.com/SU/5LDHGacpLGqiftuxZapsIshQg==>

Corp. Code 5110-6910

Nonprofit public benefit corporations -

<https://simbli.eboardsolutions.com/SU/up9YZpTJb4gRf50HwIsh9Og==>

Ed. Code 1006

Prohibition against school district employees serving on county board of education -

<https://simbli.eboardsolutions.com/SU/Qnj8IKKU84qMv8ZX5ZPu1w==>

Ed. Code 17070.10-17079.30	Leroy F. Greene School Facilities Act - https://simbli.eboardsolutions.com/SU/fu4PsUtUAb4qYYOY9breHg==
Ed. Code 17280-17317	Field Act; approval of plans and supervision of construction
Ed. Code 17365-17374	Field Act; fitness for occupancy; liability of board members
Ed. Code 215	Suicide prevention policies
Ed. Code 215.5	Student identification cards; inclusion of safety hotlines
Ed. Code 220	Prohibition of discrimination
Ed. Code 221.61	Posting of Title IX information on web site
Ed. Code 221.9	Sex equity in competitive athletics
Ed. Code 222	Reasonable accommodations; lactating students
Ed. Code 222.5	Pregnant and parenting students; notification of rights
Ed. Code 231.5-231.6	Sexual harassment policy
Ed. Code 234.4	Mandated policy on bullying prevention
Ed. Code 234.6	Bullying and harassment prevention information
Ed. Code 234.7	Student protections relating to immigration and citizenship status
Ed. Code 32282	School safety plans
Ed. Code 32283.5	Bullying; online training
Ed. Code 33479-33479.9	The Eric Parades Sudden Cardiac Arrest Prevention Act
Ed. Code 35179.4-35179.6	Interscholastic athletic programs, safety; swimming pool safety that is not part of interscholastic athletic program
Ed. Code 35183.1	Graduation ceremonies; tribal regalia or recognized object of religious/cultural significance
Ed. Code 35292.6	Stocking of menstrual products
Ed. Code 35330	Field trips and excursions; student fees
Ed. Code 38001.5	Training for security officers
Ed. Code 38080-38086	School meals
Ed. Code 39831.3	Transportation safety plan
Ed. Code 39843	Disciplinary action against bus driver; report to Department of Motor Vehicles
Ed. Code 41024	Report of expenditure of state facility funds
Ed. Code 42100	Annual statement of receipts and expenditures
Ed. Code 44030.5	Reporting change in employment status due to alleged misconduct
Ed. Code 44237	Criminal record summary
Ed. Code 44258.9	Monitoring of teacher assignments
Ed. Code 44691	Information on detection of child abuse; annual training
Ed. Code 44830.1	Certificated employees; conviction of a violent or serious felony
Ed. Code 45122.1	Classified employees; conviction of a violent or serious felony
Ed. Code 45125.1	Criminal records summary; employees of contracting entity
Ed. Code 46015	Accommodations for pregnant and parenting students; parental leave
Ed. Code 46390-46393	Emergency average daily attendance
Ed. Code 47600-47616.7	Charter Schools Act of 1992
Ed. Code 47634.2	Nonclassroom-based instruction
Ed. Code 47640-47647	Special education funding for charter schools

Ed. Code 47651	Apportionment of funds; charter schools
Ed. Code 48000	Minimum age of admission for kindergarten; transitional kindergarten
Ed. Code 48010-48011	Minimum age of admission (first grade)
Ed. Code 48206.3-48208	Students with temporary disabilities; individual instruction
Ed. Code 48850-48859	Education of foster youth and homeless students
Ed. Code 48901.1	Suspension and expulsion; willful defiance
Ed. Code 48907	Exercise of free expression; time, place and manner rules and regulations
Ed. Code 48913.5	Suspended students; homework assignments
Ed. Code 48950	Speech and other communication
Ed. Code 48985	Notices to parents in language other than English
Ed. Code 49005-49006.4	Seclusion and restraint
Ed. Code 49011	Student fees
Ed. Code 49014	Public School Fair Debt Collection Act
Ed. Code 49061	Definitions, directory information
Ed. Code 49062.5	Student records, name or gender change
Ed. Code 49070	Challenging student records
Ed. Code 49073.2	Privacy of student and parent/guardian personal information; minutes of board meeting
Ed. Code 49076.7	Student records; data privacy; social security numbers
Ed. Code 49110	Authority to issue work permits
Ed. Code 49381	Human trafficking prevention
Ed. Code 49414	Epinephrine auto-injectors
Ed. Code 49414.3	Administration of opioid antagonist
Ed. Code 49428	Notification of mental health services
Ed. Code 49430-49434	The Pupil Nutrition, Health, and Achievement Act of 2001
Ed. Code 49431.9	Prohibition of advertisement of non-nutritious foods
Ed. Code 49475	Health and safety; concussions and head injuries
Ed. Code 49501.5	Free breakfast and lunch to all students
Ed. Code 49557.5	Child Hunger Prevention and Fair Treatment Act of 2017
Ed. Code 49564	Meals for needy students
Ed. Code 49564.3	Provision of federal universal meal service
Ed. Code 49700-49701	Education of children of military families
Ed. Code 51224.7	Mathematics placement policy
Ed. Code 51225.1-51225.2	Exemption from local graduation requirements; acceptance of coursework
Ed. Code 51225.3	High school graduation requirements
Ed. Code 51225.6	Instruction in cardiopulmonary resuscitation
Ed. Code 51225.7-51225.8	Completion and submission of the Free Application for Federal Student Aid and California Dream Act Application
Ed. Code 51413	Diploma of graduation without passage of high school exit examination
Ed. Code 51745-51749.6	Independent study
Ed. Code 51925-51929	Mandatory mental health education
Ed. Code 51930-51939	California Healthy Youth Act

Ed. Code 52052	Accountability; numerically significant student subgroups
Ed. Code 52060-52077	Local control and accountability plan
Ed. Code 52075	Uniform complaint procedures
Ed. Code 56026	Special education
Ed. Code 56040.3	Availability of assistive technology device
Ed. Code 56145-56146	Special education services in charter schools
Ed. Code 56365-56366.12	Nonpublic, nonsectarian schools
Ed. Code 60600-60648.5	Assessment of academic achievement
Ed. Code 64000	Categorical programs included in consolidated application
Ed. Code 64001	School plan for student achievement; consolidated application programs
Ed. Code 65000-65001	School site councils
Ed. Code 69432.9-69432.92	Cal Grant program; notification of grade point average and high school graduation
Gov. Code 1090-1099	Prohibitions applicable to specified officers
Gov. Code 3540-3549.3	Educational Employment Relations Act
Gov. Code 3555-3559	Public employee communication, information and orientation
Gov. Code 54950-54963	The Ralph M. Brown Act
Gov. Code 6250-6270	California Public Records Act
Gov. Code 81000-91014	Political Reform Act of 1974
H&S Code 104420	Tobacco Use Prevention Education grant program
H&S Code 104559	Tobacco-free schools
Lab. Code 1198.5	Personnel records related to performance and grievance
Lab. Code 3074.2	Notice of college and career fairs
Pen. Code 1192.7	Definition of serious felony
Pen. Code 667.5	Definition of violent felony
Veh. Code 28160	Child safety alert system

Federal References

20 USC 1681-1688	Title IX of the Education Amendments of 1972; discrimination based on sex
20 USC 6311	State plan
20 USC 7221-7221j	Charter schools
34 CFR 200.1-200.78	Accountability
42 USC 11431-11435	McKinney-Vento Homeless Assistance Act

Management Resources References

	Description
Attorney General Opinion	104 Ops.Cal.Atty.Gen. 66 (2021)
Attorney General Opinion	101 Ops.Cal.Atty.Gen. 92 (2018)
Attorney General Opinion	78 Ops.Cal.Atty.Gen. 297 (1995)
Attorney General Opinion	89 Ops.Cal.Atty.Gen. 166 (2006)
Attorney General Opinion	80 Ops.Cal.Atty.Gen. 52 (1997)
CA Department of Education Publication	California School Accounting Manual
CA Office of Administrative Hearings Decisions	Student v. Horizon Instructional Systems Charter School, (2012) OAH Case No. 2011060763

California Department of Education Publication	Pupil Fees, Deposits, and Other Charges, Fiscal Management Advisory 20-01, July 23, 2020
California Dept. of Pesticide Reg. Publication	School District Integrated Pest Management Plan Template
California Interscholastic Federation Publication	Pursuing Victory with Honor, 1999
Court Decision	Ridgecrest Charter School v. Sierra Sands Unified School District, (2005) 130 Cal.App.4th 986
CSBA Publication	Charter Schools: A Guide for Governance Teams, rev. 2016
CSBA Publication	Charter Schools in Focus, Issue 2: Ensuring Effective Oversight, Governance Brief, October 2017
CSBA Publication	Uncharted Waters: Recommendations for Prioritizing Student Achievement and Effective Governance in California's Charter Schools, September 2018
U.S. DOE Guidance	Charter Schools Program: Title V, Part B of the ESEA, Nonregulatory Guidance, January 2014
Website	U.S. Department of Agriculture - https://simbli.eboardsolutions.com/SU/RslshJVkZjGiBHO8TX9tA3tqQ==
Website	National Suicide Prevention Lifeline - https://simbli.eboardsolutions.com/SU/yAd89LtBVSINaH2almpg2Q==
Website	National Domestic Violence Hotline - https://simbli.eboardsolutions.com/SU/d1fBFpjoslsh4vvBXfU68zMWg==
Website	California State Teachers Retirement System - https://simbli.eboardsolutions.com/SU/dDkW9gdO2YplusqCVo1qG2vslshw==
Website	California Public Employees Retirement System - https://simbli.eboardsolutions.com/SU/BtrWsDRenb5z2ZZethXOCw==
Website	California Department of General Services, Office of Administrative Hearings - https://simbli.eboardsolutions.com/SU/hkXUvTmkSbRSTlh3V79tXg==
Website	California Commission on Teacher Credentialing - https://simbli.eboardsolutions.com/SU/Eg0pluss7NDrgK1KmPo9MgqplusA==
Website	California Commission on Peace Officer Standards and Training - https://simbli.eboardsolutions.com/SU/T42f3sLyPIGPzJCTWmplusqxA==
Website	California Bureau of Security and Investigative Services - https://simbli.eboardsolutions.com/SU/7cVjGFeMAXplusS8ldHUhceYQ==
Website	California State Controller - https://simbli.eboardsolutions.com/SU/P16GQ6rhv8oslqGWli7phA==
Website	California Department of Pesticide Regulation - https://simbli.eboardsolutions.com/SU/oAOBjd0jGZedpcK5jhJiw==
Website	California Student Aid Commission - https://simbli.eboardsolutions.com/SU/YTrTI0NffiZjZQWbh3fewg==
Website	National Association of Charter School Authorizers - https://simbli.eboardsolutions.com/SU/9nzhOG5X2VVH42kMJnO6kg==
Website	California Charter Schools Association - https://simbli.eboardsolutions.com/SU/aplushtDM8pluszN2tpwTckx11kA==
Website	California Department of Education, Charter Schools - https://simbli.eboardsolutions.com/SU/PdGgkCs2YZ3fwPslshslshoGe7iQ==
Website	California Interscholastic Federation - https://simbli.eboardsolutions.com/SU/QthhhDMKplusJ3akAl8GRP72g==
Website	California Office of the Attorney General - https://simbli.eboardsolutions.com/SU/5qNslsh5DoKuytasYcv9khGiA==
Website	CSBA - https://simbli.eboardsolutions.com/SU/W3QxkK2FPsDsQBnMIENxGg==

Website

U.S. Department of Education -
<https://simbli.eboardsolutions.com/SU/XcSsJimoslsh3XhJKy4tplus7wplusA==>

Policy 3110: Transfer Of Funds

Status: ADOPTED

Original Adopted Date: 06/01/2022 | **Last Reviewed Date:** 06/01/2022

The Governing Board recognizes its responsibility to monitor the district's fiscal practices to ensure accountability regarding the expenditure of public funds and compliance with legal requirements.

The total amount budgeted by the district for each major classification of expenditures, as listed in the California Department of Education's budget forms, shall be the maximum amount which the district may expend for that classification for the school year. (Education Code 42600)

However, when it is in the best interest of the district, the Board may:

1. At any time, adopt a written resolution providing for transfers from the designated fund balance or the unappropriated fund balance to any expenditure classification or between classifications. The resolution shall be filed with the County Superintendent of Schools and the County Auditor. (Education Code 42600)
2. Direct the temporary transfer of monies held in any district fund or account to another fund or account as necessary for the payment of obligations. Such borrowing shall occur only when the fund or account receiving the money will earn sufficient income during the current fiscal year to repay the amount transferred. No more than 75 percent of the maximum amount held in any fund or account during the current fiscal year may be transferred. Amounts transferred shall be repaid in the same fiscal year, or in the following fiscal year if the transfer takes place within the final 120 calendar days of a fiscal year. (Education Code 42603)
3. At the close of a school year, request that the County Superintendent make transfers between the designated fund balance or the unappropriated fund balance and any expenditure classification(s), or balance any expenditure classifications of the district budget as necessary for the payment of obligations incurred during that school year. (Education Code 42601)
4. If any special reserve funds that are maintained for capital outlay or other purposes pursuant to Education Code 42842 are not actually encumbered for ongoing expenses, transfer those monies into the general fund for the general operating purposes of the district. If any monies remain in the special reserve fund at the conclusion of a project, the Board may submit a written request to the County Superintendent, Auditor, and Treasurer to discontinue the special reserve fund and transfer those monies to the district's general fund. (Education Code 42841-42843)
5. Transfer monies between other funds or accounts when authorized by law.

Policy Reference Disclaimer: These references are not intended to be part of the policy itself, nor do they indicate the basis or authority for the board to enact this policy. Instead, they are provided as additional resources for those interested in the subject matter of the policy.

State References

Description

Ed. Code 16095	Transfer of district funds to district state school building fund - https://simbli.eboardsolutions.com/SU/DckNjgplus9tDnTa0uS0C6Kdw==
Ed. Code 41301	Section A state school fund allocation schedule
Ed. Code 42125	Designated and unappropriated fund balances
Ed. Code 42238-42251	Apportionments to districts
Ed. Code 42238.01-42238.07	Local control funding formula
Ed. Code 42600	District budget limitation on expenditure
Ed. Code 42601	Transfers between funds to permit payment of obligations at close of year
Ed. Code 42603	Transfer of monies held in any fund or account to another fund; repayment
Ed. Code 42840-42843	Special reserve fund
Ed. Code 5200	Districts governed by boards of education
Ed. Code 52616.4	Expenditures from adult education fund

Ed. Code 78

Definition, governing board

Management Resources References

Description

CA Department of Education Publication

California School Accounting Manual

Website

California Department of Education -

<https://simbli.eboardsolutions.com/SU/os2jq5DcA2RawmY2VZ5FZQ==>

Website

CSBA -

<https://simbli.eboardsolutions.com/SU/W3QxkK2FPsDsQBnMIENxGg==>

Website

Fiscal Crisis and Management Assistance Team -

<https://simbli.eboardsolutions.com/SU/1KDBnxplus9GciDTyFvbLOOxQ==>

Policy 3523: Electronic Signatures

Status: ADOPTED

Original Adopted Date: 06/01/2022 | **Last Reviewed Date:** 06/01/2022

The Governing Board believes that the use of electronic records and signatures is a convenient paperless option that can increase efficiency in commercial and administrative transactions, reduce costs, and contribute to environmental sustainability in district operations. The Board authorizes the use of electronic signatures in district operations when authorized by law.

The Superintendent or designee shall ensure that any electronic signature utilized by the district conforms with criteria described in law and that the level of security is sufficient for the transaction being conducted. (Government Code 16.5; 2 CCR 22003, 22005)

The Superintendent or designee shall retain electronic records in accordance with law and regulations, and as specified in BP/AR 3580 - District Records.

Policy Reference Disclaimer: These references are not intended to be part of the policy itself, nor do they indicate the basis or authority for the board to enact this policy. Instead, they are provided as additional resources for those interested in the subject matter of the policy.

State References

- 2 CCR 22000-22005
- 5 CCR 16020-16022
- 5 CCR 16023-16027
- 5 CCR 430
- 5 CCR 432
- Civ. Code 1633.1-1633.17
- Civ. Code 1798.29
- Ed. Code 35252-35255
- Ed. Code 44031
- Ed. Code 49060-49079.7
- Ed. Code 8234
- Gov. Code 16.5
- Gov. Code 6252-6265
- Gov. Code 811.2

Description

- Public entity use of electronic signatures - <https://simbli.eboardsolutions.com/SU/jjoxXkoplusnISsKsUaPslshQplusYg==>
- Records, general provisions
- District records, retention and destruction
- Individual student records; definition
- Student records
- Uniform Electronic Transactions Act
- District records; breach of security - <https://simbli.eboardsolutions.com/SU/LBkkDX8OIBFu9JplusO9hdW9w==>
- Records and reports
- Personnel file contents and inspection
- Student records
- Electronic signatures; child care and development programs
- Electronic signatures
- Inspection of public records
- Definition of public entity

Federal References

- 15 USC 7001-7006
- 20 USC 1232g
- 20 USC 1400-1482
- 34 CFR 300-300.818
- 34 CFR 99.1-99.8

Description

- Electronic Records and Signatures in Commerce Act
- Family Educational Rights and Privacy Act (FERPA) of 1974
- Individuals with Disabilities Education Act
- Assistance to states for the education of students with disabilities
- Family Educational Rights and Privacy Act

Management Resources References

- CA Department of Education Publication

Description

- Management Bulletin 17-13, October 2017

Policy 3550: Food Service/Child Nutrition Program

Status: ADOPTED

Original Adopted Date: 06/01/2022 | Last Reviewed Date: 06/01/2022

The Governing Board recognizes that adequate, nourishing food is essential to student health **and well-being**, development, and ability to learn. The Superintendent or designee shall develop strategies to increase students' access to **and participation in** the district's food service programs and **maintain fiscal integrity of the** programs **in accordance with law**.

Foods and beverages available through the district's food service program shall:

1. Be carefully selected so as to contribute to students' nutritional well-being and the prevention of disease
2. Meet or exceed nutrition standards specified in law
3. Be prepared in ways that will appeal to students, retain nutritive quality, and foster lifelong healthful eating habits
4. Be served in age-appropriate portions
5. **Be provided at no cost to students who request a meal**

At the beginning of each school year, the Superintendent or designee shall communicate information related to the district's food service programs to the public through available means, including, but not limited to, the district's web site, social media, flyers, and school publications.

The district's food service program shall give priority to serving unprocessed foods and fresh fruits and vegetables.

District schools are encouraged to establish school gardens and/or farm-to-school projects to increase the availability of safe, fresh, seasonal fruits and vegetables for school meals and to support the district's nutrition education program.

To the extent possible, the school meal program shall be coordinated with the nutrition education program, instructional program for teachers, parents/guardians and food service employees, available community resources, and other related district programs.

To encourage student participation in school meal programs, schools may offer multiple choices of food items within a meal service, provided all food items meet nutrition standards and all students are given an opportunity to select any food item.

The Superintendent or designee may invite students and parents/guardians to participate in the selection of foods of good nutritional quality for school menus.

Students shall be allowed adequate time and space to eat meals. To the extent possible, school, recess, and transportation schedules shall be designed to **promote** participation in school meal programs.

The Superintendent or designee shall periodically review the adequacy of school **cafeterias and** facilities for food preparation **and consumption**.

In accordance with law, the Superintendent or designee shall develop and maintain a food safety program in order to reduce the risk of foodborne hazards at each step of the food preparation **and** service **process**.

The Superintendent or designee shall annually report to the Board on student participation in the district's nutrition

programs and the extent to which the district's food **service** program meets state and federal nutrition standards for foods and beverages. In addition, the Superintendent or designee shall provide all necessary and available documentation required for the Administrative Review conducted by the California Department of Education (CDE) to ensure the food service program's compliance with federal requirements related to nutrition standards, meal patterns, provision of drinking water, school meal environment, food safety, and other areas as required by the CDE.

Policy Reference Disclaimer: These references are not intended to be part of the policy itself, nor do they indicate the basis or authority for the board to enact this policy. Instead, they are provided as additional resources for those interested in the subject matter of the policy.

State References

	Description
5 CCR 15510	Mandatory meals for needy students
5 CCR 15530-15535	Nutrition education
5 CCR 15550-15565	School lunch and breakfast programs
5 CCR 15575-15578	Requirements for foods and beverages outside the federal meals program
Ed. Code 35182.5	Contracts for advertising
Ed. Code 38080-38103	Cafeteria; establishment and use
Ed. Code 45103.5	Contracts for management consulting services; restrictions
Ed. Code 48432.3	Voluntary enrollment in continuation education
Ed. Code 49430-49434	Pupil Nutrition, Health, and Achievement Act of 2001
Ed. Code 49490-49494	School breakfast and lunch programs
Ed. Code 49500-49505	School meals
Ed. Code 49501.5	California Universal Meals Program
Ed. Code 49510-49520	Nutrition
Ed. Code 49530-49536	Child Nutrition Act
Ed. Code 49540-49546	Child care food program
Ed. Code 49547-49548.3	Comprehensive nutrition services
Ed. Code 49550-49562	Meals for needy students
Ed. Code 49570	National School Lunch Act
Ed. Code 51795-51797	School instructional gardens
H&S Code 113700-114437	California Retail Food Code; sanitation and safety requirements

Federal References

	Description
42 USC 1751-1769j	National School Lunch Program
42 USC 1758b	Local wellness policy
42 USC 1761	Summer Food Service Program and Seamless Summer Feeding Option
42 USC 1769a	Fresh Fruit and Vegetable Program
42 USC 1771-1793	Child Nutrition Act
42 USC 1772	Special Milk Program
42 USC 1773	School Breakfast Program
7 CFR 210.1-210.31	National School Lunch Program
7 CFR 215.1-215.18	Special Milk Program
7 CFR 220.2-220.22	National School Breakfast Program
7 CFR 245.1-245.13	Eligibility for free and reduced-price meals and free milk

Management Resources References

Description

CA Project Lean Publication	Policy in Action: A Guide to Implementing Your Local School Wellness Policy, October 2006
California Department of Education Publication	Healthy Children Ready to Learn, January 2005
California Department of Education Publication	Professional Standards in the School Nutrition Programs, Management Bulletin SNP-13-2020, Updated January 2022
CSBA Publication	Building Healthy Communities: A School Leader's Guide to Collaboration and Community Engagement, 2009
CSBA Publication	Nutrition Standards for Schools: Implications for Student Wellness, Policy Brief, rev. October 2007
CSBA Publication	Monitoring for Success: Student Wellness Policy Implementation Monitoring Report and Guide, 2007
CSBA Publication	Student Wellness: A Healthy Food and Physical Activity Policy Resource Guide, rev. April 2006
U.S. Department of Agriculture Publication	School Breakfast Toolkit
U.S. Department of Agriculture Publication	Civil Rights Compliance and Enforcement - Nutrition Programs and Activities, FNS Instruction 113-1, November 2005
U.S. Department of Agriculture Publication	Dietary Guidelines for Americans, 2005
U.S. Department of Agriculture Publication	Food Buying Guide for Child Nutrition Programs, December 2007
U.S. Department of Agriculture Publication	Fresh Fruit and Vegetable Program: Handbook for Schools, December 2010
U.S. Department of Agriculture Publication	Guidance for School Food Authorities: Developing a School Food Safety Program Based on the Process Approach to HACCP Principles, June 2005
Website	U.S. Department of Agriculture, Food and Nutrition Service - https://simbli.eboardsolutions.com/SU/Wry6HD6BSTBkfn7BqplusR7BQ==
Website	California Farm Bureau Federation - https://simbli.eboardsolutions.com/SU/9DOOfPfd6z2oylYGKzj0qKA==
Website	Nourish California - https://simbli.eboardsolutions.com/SU/5GeuVdU7HE4aLG3NFy4PTg==
Website	California Project LEAN (Leaders Encouraging Activity and Nutrition) - https://simbli.eboardsolutions.com/SU/lzuCbbhn3rBrfeZTSNnVCw==
Website	Centers for Disease Control and Prevention - https://simbli.eboardsolutions.com/SU/UUjirqtkk65lplusLWplusApdRjg==
Website	National Alliance for Nutrition and Activity - https://simbli.eboardsolutions.com/SU/GZJffQ4Hi71GbK8LPjKsg==
Website	California School Nutrition Association - https://simbli.eboardsolutions.com/SU/KnWOpY7WknrOcdh5fJ85QQ==
Website	California Department of Education, Nutrition Services Division - https://simbli.eboardsolutions.com/SU/O5xpn2rTFL2uz0BslshlorGXQ==
Website	California Department of Public Health - https://simbli.eboardsolutions.com/SU/plusKghL3cnZRJOzDybcVsugA==
Website	California Healthy Kids Resource Center - https://simbli.eboardsolutions.com/SU/Ve9Yf61snLK7fRzOPU1xiQ==
Website	CSBA - https://simbli.eboardsolutions.com/SU/W3QxkK2FPsDsQBnMIENxGg==

Policy 3551: Food Service Operations/Cafeteria Fund

Status: ADOPTED

Original Adopted Date: 06/01/2022 | Last Reviewed Date: 06/01/2022

The Governing Board intends that school food services shall be a self-supporting, nonprofit program. To ensure program quality and cost effectiveness, the Superintendent or designee shall centralize and direct the purchasing of foods and supplies, the planning of menus, and the auditing of all food service accounts for the district.

The Superintendent or designee shall ensure that food service director(s) possess the qualifications required by 7 CFR 210.30 and California Department of Education (CDE) standards.

At least once each year, food service administrators, other appropriate personnel who conduct or oversee administrative procedures, and other food service personnel shall receive training provided by CDE. (42 USC 1776)

Meal Sales

Any student who requests a meal shall be served a nutritionally adequate breakfast and lunch free of charge, each school day. (Education Code 49501.5)

As permitted by law, additional or second meals, adult meals, and other nonprogram foods, such as smart snack compliant food and beverages sold in vending machines, may be sold to students. (Education Code 38082, 49501.5)

Meals may be sold to district employees, Board members, and employees or members of the fund or association maintaining the cafeteria. (Education Code 38082)

In addition, meals may be sold to nonstudents, including parents/guardians, volunteers, students' siblings, or other individuals, who are ***authorized by the Superintendent or designee to be*** on campus. Any meals served to nonstudents shall not be subsidized by federal or state reimbursements, food service revenues, or U.S. Department of Agriculture (USDA) foods.

Meal prices, as recommended by the Superintendent or designee and approved by the Board, shall be based on the costs of providing food services and consistent with Education Code 38084 and 42 USC 1760.

The Superintendent or designee shall establish strategies and procedures for the collection of meal payments. Such procedures shall conform with 2 CFR 200.426 and any applicable CDE guidance. The Superintendent or designee shall clearly communicate these procedures to students and parents/guardians, and shall make this policy and the accompanying administrative regulation available to the public pursuant to Education Code 49557.5.

Cafeteria Fund and Account

The Superintendent or designee shall establish a cafeteria fund independent of the district's general fund.

The Superintendent or designee shall ensure that state and federal funds provided through school meal programs are allocated only for purposes related to the operation or improvement of food services and for reasonable and necessary indirect program costs as allowed by law.

The wages, salaries, and benefits of food service employees shall be paid from the cafeteria fund. (Education Code 38103)

Contracts with Outside Services

With Board approval, the district may enter into a contract for food service consulting services or management services in one or more district schools. (Education Code 45103.5; 42 USC 1758; 7 CFR 210.16)

Procurement of Foods, Equipment and Supplies

To the maximum extent practicable, foods purchased for use in school meals by the district or by any entity purchasing food on its behalf shall be domestic commodities or products. Domestic commodity or product means an agricultural commodity that is produced in the United States and a food product that is processed in the United States substantially using agricultural commodities that are produced in the United States. (42 USC 1760; 7 CFR 210.21)

A nondomestic food product may be purchased for use in the district's food service program only as a last resort when the product is not produced or manufactured in the United States in sufficient and reasonably available quantities of a satisfactory quality, or when competitive bids reveal the costs of a United States product are significantly higher than the nondomestic product. In such cases, the Superintendent or designee shall retain documentation justifying the use of the exception.

Furthermore, the district shall accept a bid or price for an agricultural product grown in California before accepting a bid or price for an agricultural product grown outside the state, if the quality of the California-grown product is comparable and the bid or price does not exceed the lowest bid or price of a product produced outside the state. (Food and Agriculture Code 58595)

Bid solicitations and awards for purchases of equipment, materials, or supplies in support of the district's child nutrition program, or for contracts awarded pursuant to Public Contract Code 2000, shall be consistent with the federal procurement standards in 2 CFR 200.318-200.326. Awards shall be let to the most responsive and responsible party. Price shall be the primary consideration, but not the only determining factor, in making such an award. (Public Contract Code 20111)

Program Monitoring and Evaluation

The Superintendent or designee shall present to the Board, at least annually, financial reports regarding revenues and expenditures related to the food service program.

The Superintendent or designee shall provide all necessary documentation required for the Administrative Review conducted by CDE to ensure compliance of the district's food service program with federal requirements.

Policy Reference Disclaimer: These references are not intended to be part of the policy itself, nor do they indicate the basis or authority for the board to enact this policy. Instead, they are provided as additional resources for those interested in the subject matter of the policy.

State References

Description

5 CCR 15550-15565	School lunch and breakfast programs
Ed. Code 38080-38086	School meals
Ed. Code 38090-38095	Cafeterias, funds and accounts
Ed. Code 38100-38103	Cafeterias, allocation of charges
Ed. Code 42646	Alternate payroll procedure

Ed. Code 45103.5	Contracts for management consulting services; restrictions
Ed. Code 49490-49493	School breakfast and lunch programs
Ed. Code 49500-49505	School meals
Ed. Code 49550-49564.5	Meals for needy students
Ed. Code 49554	Contract for services
Ed. Code 49580-49581	Food recovery program
F&A Code 58595	Preference for California-grown agricultural products
H&S Code 113700-114437	California Retail Food Code; sanitation and safety requirements
Pub. Cont. Code 2000-2002	Responsive bidders
Pub. Cont. Code 20111	Contracts over \$50,000; contracts for construction; award to lowest responsible bidder

Federal References

2 CFR 200	Appendix VII Indirect cost proposals
2 CFR 200.318-200.326	Procurement standards
2 CFR 200.400-200.475	Cost principles
2 CFR 200.56	Indirect costs, definition
42 USC 1751-1769j	School Lunch Program
42 USC 1771-1793	Child nutrition
42 USC 1773	School Breakfast Program
7 CFR 210.1-210.31	National School Lunch Program
7 CFR 210.1-210.33	National School Lunch Program
7 CFR 220.1-220.21	National School Breakfast Program
7 CFR 220.1-220.22	National School Breakfast Program
7 CFR 245.8	Nondiscrimination practices for students eligible for free and reduced price meal and free milk
7 CFR 250.1-250.70	USDA foods

Description

Management Resources References

CA Department of Education Publication	California School Accounting Manual
California Department of Education Publication	Pricing of Adult Meals in the National School Lunch and School Breakfast Programs, NSD Management Bulletin, SNP-04-2021, August 2021
California Department of Education Publication	Procuring and Monitoring of Food Service Management Contracts, NSD Management Bulletin, SNP-13-2015, January 2015
California Department of Education Publication	Cafeteria Funds--Allowable Uses, NSD Management Bulletin, NSD-SNP-05-2020, February 2020
California Department of Education Publication	Food Distribution Program Administrative Manual
California Department of Education Publication	Storage and Inventory Management of U.S. Department of Agriculture Foods, NSD Management Bulletin, FDP-01-2018, January 2018
U.S. Department of Agriculture Publication	Indirect Costs: Guidance for State Agencies and School Food Authorities SP 60-2016, September 2016
U.S. Department of Agriculture Publication	Compliance with and Enforcement of the Buy American Provision in the National School Lunch Program, SP-38-2017, June 2017
U.S. Department of Agriculture Publication	Discretionary Elimination of Reduced Price Charges in the School Meal Programs, SP 17-2014, January 2014
U.S. Department of Agriculture Publication	Unpaid Meal Charges: Local Meal Charge Policies, SP-46-2016, July 2016

U.S. Dept of Agriculture Publication

Website

Website

Website

School Meals - FAQs

U.S. Department of Agriculture, Food and Nutrition Service -
<https://simbli.eboardsolutions.com/SU/Wry6HD6BSTBkfn7BqplusR7BQ==>

California Department of Education, Nutrition Services Division -
<https://simbli.eboardsolutions.com/SU/O5xpn2rTFL2uz0BslshlorGXQ==>

California School Nutrition Association -
<https://simbli.eboardsolutions.com/SU/KnWOpY7WknrOcdh5fJ85QQ==>

Policy 3553: Free And Reduced Price Meals

Status: ADOPTED

Original Adopted Date: 06/01/2022 | Last Reviewed Date: 06/01/2022

The Governing Board recognizes that adequate nutrition is essential to the development, health **and well-being**, and learning of **all** students. The Superintendent or designee shall facilitate and encourage the participation of all students in the district's food service program.

Each school day, the district shall provide, **free of charge, a** nutritionally adequate **breakfast and lunch** for **any student who requests a meal.** (Education Code **49501.5**)

To provide optimal nutrition and **ensure that schools receive maximum federal meal reimbursement**, the Superintendent or designee shall assess the eligibility of district schools to **operate a federal** universal meal service provision, such as Provision 2 or the Community Eligibility Provision, pursuant to 42 USC 1759a. **The Superintendent or designee** shall **submit an application to operate a federal universal meal provision** to the California Department of Education (CDE) **on behalf of any district school that meets the definition of a "high poverty school."** (Education Code **49564.3**)

The Superintendent or designee shall ensure that meals **served under the school nutrition** program meet applicable state and/or federal nutritional standards in accordance with law, Board policy, and administrative regulation.

The Board shall approve, and shall submit to CDE for approval, a plan that ensures that students eligible to receive free or reduced-price meals are not treated differently from other students and that **meets other requirements specified in** Education Code 49557.

Confidentiality/Release of Records

All applications and records related to eligibility for the free and reduced-price meal program shall be confidential and may not be **disclosed** except as provided by law and authorized by the Board or pursuant to a court order. (Education Code 49558)

The Board authorizes designated employees to use records pertaining to **an individual student's** eligibility for the free and reduced-price meal program for the following purposes: (Education Code 49558)

1. Disaggregation of academic achievement data
2. Identification of students eligible for services under the federal Elementary and Secondary Education Act pursuant to 20 USC 6301-6576
3. **Facilitation of targeted educational services and supports to individual students based on the local control accountability plan**

If a student transfers from the district to another district, charter school, county office of education program, or private school, the Superintendent or designee may share the student's meal eligibility information to the other educational agency to assist **that other educational agency in ensuring that the student continues to receive school meals.**

The Superintendent or designee may release the name and eligibility status of a student participating in the free or reduced-price meal program to another school district, charter school, or county office of education that is serving a student living in the same household for purposes related to program eligibility and data used in local control funding formula **(LCFF)** calculations. (Education Code 49558)

The Superintendent or designee may release the name and eligibility status of a student participating in the free or reduced-price meal program to the Superintendent of Public Instruction for purposes of determining allocations under the **LCFF** and for assessing accountability of that funding. (Education Code 49558)

The Superintendent or designee may release information on the school lunch program application to the local agency that determines eligibility for participation in the Medi-Cal program if the student has been approved for free meals or, if included in the agreement with the local agency, for reduced-price meals. *The Superintendent or designee* also may release information on the school lunch application to the local agency that determines eligibility for CalFresh or another nutrition assistance program authorized under 7 CFR 210.1 if the student has been approved for free or reduced-price meals. Information may be released for these purposes only if the student's parent/guardian consents to the sharing of information and the district has entered into a memorandum of understanding with the local agency which, at a minimum, includes the roles and responsibilities of the district and local agency and the process for sharing the information. After sharing information with the local agency for purposes of determining eligibility for that program, no further information shall be shared unless otherwise authorized by law. (Education Code 49557.2, 49557.3, 49558)

Policy Reference Disclaimer: These references are not intended to be part of the policy itself, nor do they indicate the basis or authority for the board to enact this policy. Instead, they are provided as additional resources for those interested in the subject matter of the policy.

State References

	Description
5 CCR 15510	Mandatory meals for needy students
5 CCR 15530-15535	Nutrition education
5 CCR 15550-15565	School lunch and breakfast programs
Ed. Code 48980	Parent/Guardian notifications
Ed. Code 49430-49434	Pupil Nutrition, Health, and Achievement Act of 2001
Ed. Code 49490-49494	School breakfast and lunch programs
Ed. Code 49500-49505	School meals
Ed. Code 49501.5	California Universal Meals Program
Ed. Code 49510-49520	Nutrition
Ed. Code 49530-49536	Child Nutrition Act
Ed. Code 49547-49548.3	Comprehensive nutrition services
Ed. Code 49550-49564.5	Meals for needy students
Ed. Code 49564.3	High-poverty schools; universal meal service

Federal References

	Description
20 USC 1232g	Family Educational Rights and Privacy Act (FERPA) of 1974
20 USC 6301-6576	Title I Improving the Academic Achievement of the Disadvantaged
42 USC 1751-1769j	School Lunch Program
42 USC 1771-1791	Child nutrition
42 USC 1773	School Breakfast Program
7 CFR 210.1-210.31	National School Lunch Program
7 CFR 220.10-220.21	National School Breakfast Program
7 CFR 245.1-245.13	Eligibility for free and reduced-price meals and free milk

Management Resources References

	Description
California Department of Education Publication	Clarification on the Sharing of Individual Student Eligibility Information for Local Control and Accountability Plan Purposes, Management Bulletin SNP-02-2018, May 2018
CSBA Publication	Student Wellness: A Healthy Food and Physical Activity Policy Resource Guide, 2012

CSBA Publication	Monitoring for Success: A Guide for Assessing and Strengthening Student Wellness Policies, rev. 2012
U.S. Department of Agriculture Publication	Provision 2 Guidance: National School Lunch and School Breakfast Programs, Summer 2002
U.S. Dept of Agriculture Publication	Eligibility Manual for School Meals: Determining and Verifying Eligibility, July 2017
Website	U.S. Department of Agriculture, Food and Nutrition Service - https://simbli.eboardsolutions.com/SU/Wry6HD6BSTBkfn7BqplusR7BQ==
Website	Nourish California - https://simbli.eboardsolutions.com/SU/5GeuVdU7HE4aLG3NFy4PTg==
Website	California Project LEAN (Leaders Encouraging Activity and Nutrition) - https://simbli.eboardsolutions.com/SU/lzuCbbhn3rBrfeZTSNnVCw==
Website	California Department of Education, Nutrition Services Division - https://simbli.eboardsolutions.com/SU/O5xpn2rTFL2uz0BslshlorGXQ==
Website	CSBA - https://simbli.eboardsolutions.com/SU/W3QxkK2FPsDsQBnMIENxGg==